

Description

The AP8802 is a step-down DC/DC converter designed to drive LEDs with a constant current. The device can drive up to thirteen LEDs, depending on the forward voltage of the LEDs, in series from a voltage source of 8V to 48V. Series connection of the LEDs provides identical LED currents resulting in uniform brightness and eliminating the need for ballast resistors. The AP8802 switches at frequency up to 600kHz. This allows the use of small size external components, hence minimizing the PCB area needed.

Maximum output current of AP8802 is set via an external resistor connected between the V_{IN} and SET input pins. Dimming is achieved by applying either a DC voltage or a PWM signal at the CTRL input pin. An input voltage of 0.2V or lower at CTRL shuts down the output at SW and puts the device into a low-current standby state.

Features

- LED driving current up to 1A
- High efficiency up to 92%
- Operating input voltage up to 48V
- High switching frequency up to 600kHz
- PWM/DC input for dimming control
- Built-in output open-circuit protection
- SO-8, SO-8EP and U-DFN3030-10 are available in "Green" Molding Compound (No Br, Sb)
- Lead Free Finish/ RoHS Compliant (Note 1)

Notes: 1. EU Directive 2002/95/EC (RoHS). All applicable RoHS exemptions applied. Please visit our website at http://www.diodes.com/products/lead_free.html.

Pin Assignments

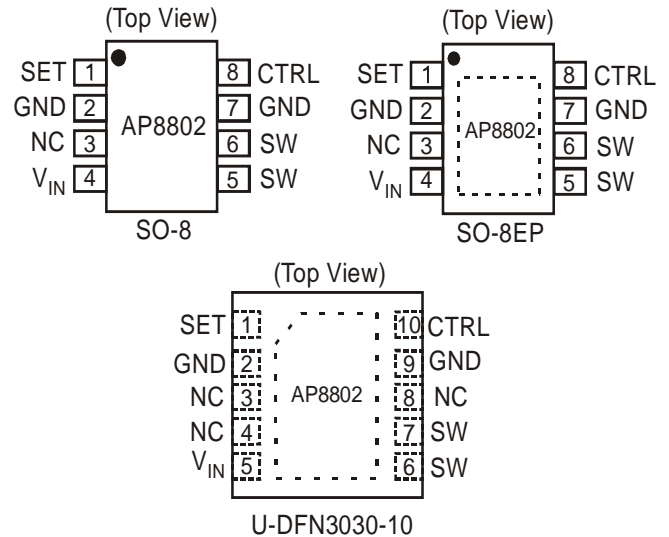

Applications

- Commercial & industrial lighting
- Small LCD panel backlight
- Appliances interior lighting
- Architecture Detail lighting

Typical Application Circuit

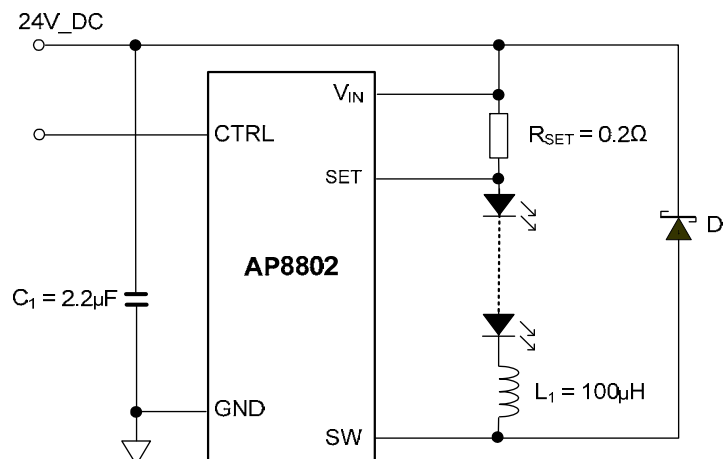

Pin Descriptions

Name	SO-8	SO-8EP	U-DFN3030-10	Description
SW	6, 5	6, 5	7, 6	Switch Pin. Connect inductor/freewheeling diode here, minimizing track length at this pin to reduce EMI.
GND	2	2	2, 9	GND pin
SET	1	1	1	Set Nominal Output Current Pin. Configure the output current of the device.
CTRL	8	8	10	Dual function dimming control pin. <ul style="list-style-type: none"> Input voltage of 0.2V or lower forces the device into low current standby mode and shuts off the output. A PWM signal (driven by an open-drain/collector source) allows the output current to be adjusted over a wide range up to 100%. An analog voltage between 0.3V and 2.5V adjusts the output current between 25% and 200% of the current set by $0.2V/R_S$. The input impedance is about 50k Ω , and if the pin is left open $V_{CTRL} = V_{REF}$
V _{IN}	4	4	5	Input Supply Pin. Must be locally bypassed.
NC	3	3	3, 4, 8	No connection
EP	-	EP	EP	Exposed pad: Internally connected to IC substrate. It should be connected to GND and as large as possible thermal mass for improved thermal impedance and power dissipation capability. However the exposed pad is not a Power GND return path. The dedicated GND pins must be connected to 0V. See Land Pad diagrams.

Functional Block Diagram

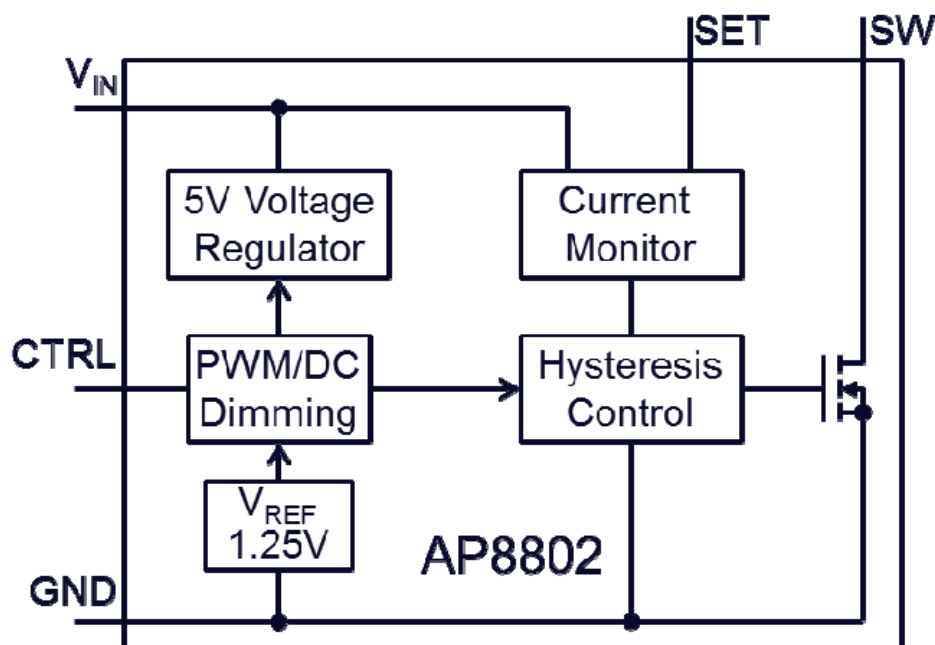

Absolute Maximum Ratings ($T_A = 25^\circ\text{C}$)

Symbol	Parameter	Rating	Unit
V_{IN}	V_{IN} pin voltage	-0.3 ~ +50	V
V_{SW}	SW voltage	-0.3 ~ +50	V
V_{CTRL}	CTRL Pin Input Voltage	-0.3 to +6	V
V_{SENSE}	SET Voltage (Note 2)	+0.3 to -5	V
T_J	Junction Temperature	150	$^\circ\text{C}$
T_{LEAD}	Lead Temperature Soldering	300	$^\circ\text{C}$
T_{ST}	Storage Temperature Range	-65 to +150	$^\circ\text{C}$

Note: 2 (measured with respect to V_{IN})

Caution: Stresses greater than the 'Absolute Maximum Ratings' specified above, may cause permanent damage to the device. These are stress ratings only; functional operation of the device at these or any other conditions exceeding those indicated in this specification is not implied. Device reliability may be affected by exposure to absolute maximum rating conditions for extended periods of time.

Semiconductor devices are ESD sensitive and may be damaged by exposure to ESD events. Suitable ESD precautions should be taken when handling and transporting these devices

Recommended Operating Conditions ($T_A = 25^\circ\text{C}$)

Symbol	Parameter	Min.	Max.	Unit
V_{IN}	Operating input voltage relative to GND	8.0	48	V
V_{CTRLDC}	Voltage range for 24% to 200% DC dimming relative to GND (Note 3)	0.3	2.5	V
V_{CTRL}	Voltage low for PWM dimming relative to GND	0	0.2	V
f_{OSC}	Maximum switching frequency		600	kHz
T_A	Ambient temperature range	-40	+105	$^\circ\text{C}$
Duty Cycle	Using inductor $\geq 100\mu\text{H}$ (Note 4)	0.1	0.95	

Notes: 3. For 100% brightness either leave floating or connect to 1.25V relative to GND.

4. For most applications the LED current will be within 8% over the duty cycle range specified. Duty cycle accuracy is also dependent on propagation delay. Smaller size inductors can be used but LED current accuracy may be greater than 8% at extremes of duty cycle. This is most noticeable at low duty cycles (less than 0.1) or when the input voltage is high and only one LED is being driven.

Electrical Characteristics ($T_A = 25^\circ\text{C}$, $V_{IN} = 12\text{V}$; unless otherwise specified)

Symbol	Parameter	Conditions	Min	Typ.	Max	Unit
I_{OUT}	Continuous switch current	(Note 5)			1	A
I_Q	Quiescent Current		-	75	120	μA
V_{THD}	Internal Threshold Voltage		184	200	216	mV
$V_{SENSEHYS}$	Sense threshold hysteresis			15		%
SET	SET pin input current	$V_{SET} = V_{IN} - 0.2$	-	5	-	μA
V_{REF}	Internal Reference Voltage		-	1.25	-	V
$R_{DS(ON)}$	On Resistance of MOSFET	$I_{SW} = 0.8\text{A}$		0.65	1.1	Ω
$I_{SW_Leakage}$	Switch leakage current		-	-	8	μA
θ_{JA}	Thermal Resistance Junction-to-Ambient	SO-8 (Note 6)	-	82	-	$^\circ\text{C/W}$
		SO-8EP (Note 6)	-	45	-	$^\circ\text{C/W}$
		U-DFN3030-10 (Note 6)	-	38	-	$^\circ\text{C/W}$
θ_{JC}	Thermal Resistance Junction-to-Case	SO-8 (Note 6)	-	52	-	$^\circ\text{C/W}$
		SO-8EP (Note 6)	-	7	-	$^\circ\text{C/W}$
		U-DFN3030-10 (Note 6)	-	24	-	$^\circ\text{C/W}$

Notes: 5. Refer to figure 8 for the device derating curve.
6. Test condition for SO-8, SO-8EP and U-DFN3030-10: Device mounted on FR-4 PCB, 2"x2", 2oz copper, minimum recommended pad layout on top layer and thermal vias to bottom layer ground plane. For better thermal performance, larger copper pad for heat-sink is needed.

Typical Characteristics

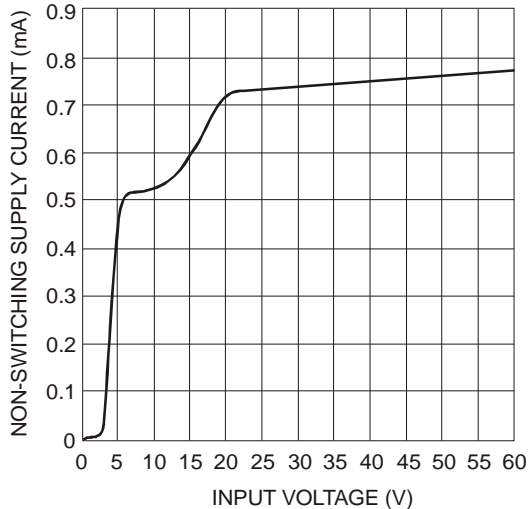

Fig. 2 Supply Current (not switching) vs. Input Voltage

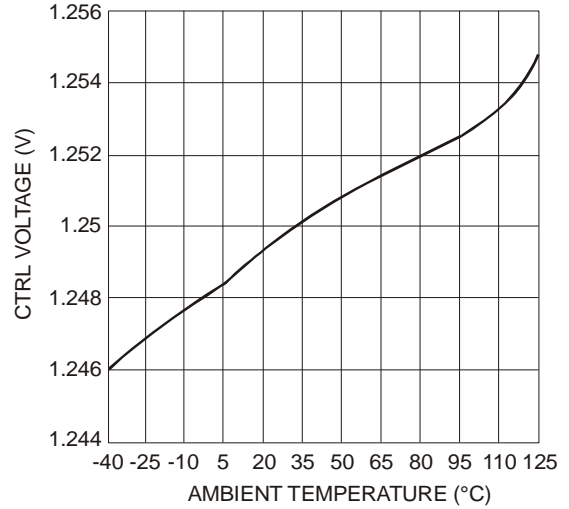

Fig. 3 V_{CTRL} vs. Ambient Temperature

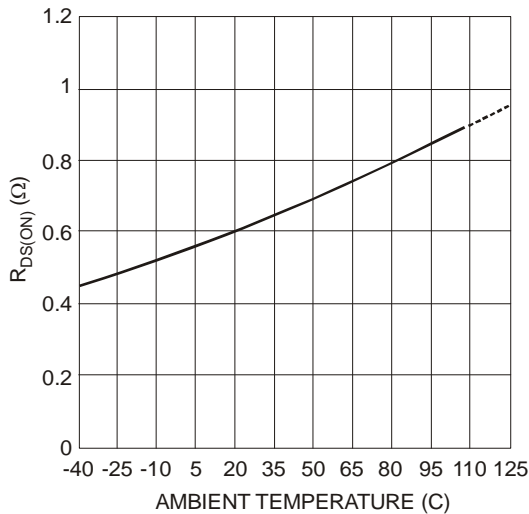

Fig. 4 $R_{DS(ON)}$ vs Ambient Temperature

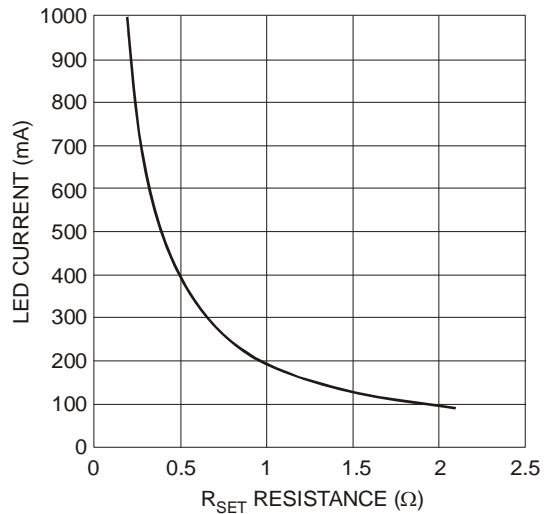

Fig. 5 LED Current vs. R_{SET}

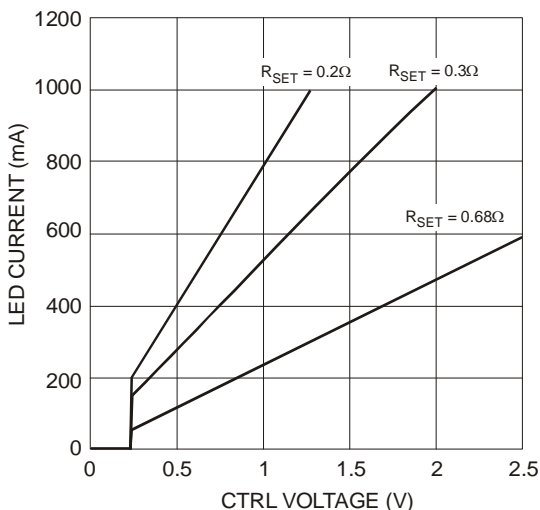

Fig. 6 LED Current vs. V_{CTRL}

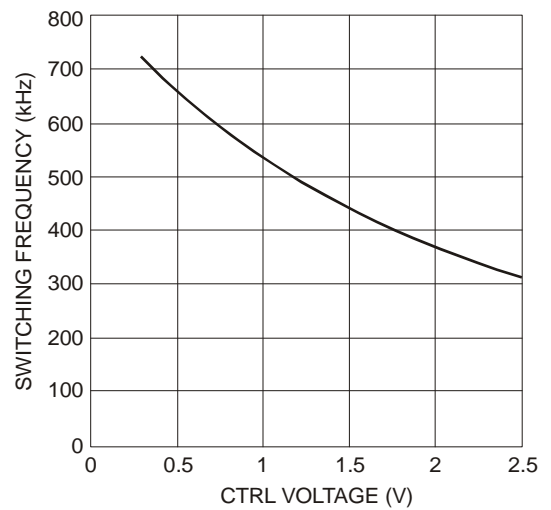

Fig. 7 Switching Frequency vs. V_{CTRL}

Typical Characteristics $T_A = 25^\circ\text{C}$, $V_{IN} = 60\text{V}$, $L = 68\mu\text{H}$ unless otherwise stated

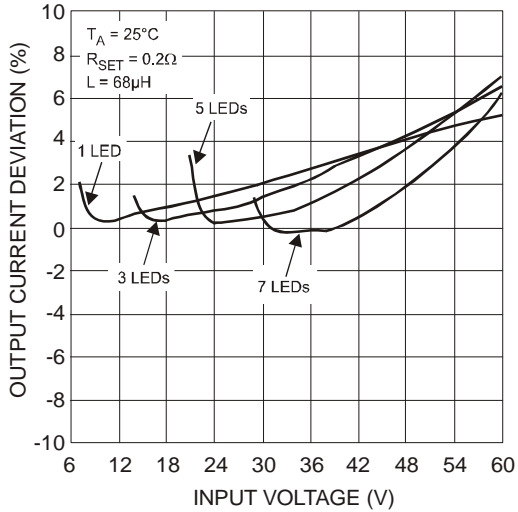

Fig 8. LED Current vs. Input Voltage

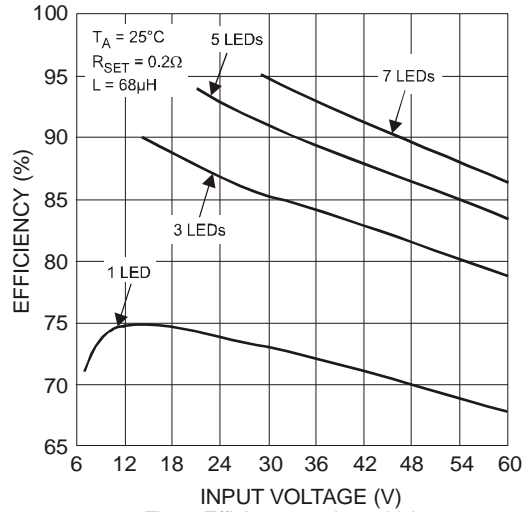

Fig 9. Efficiency vs. Input Voltage

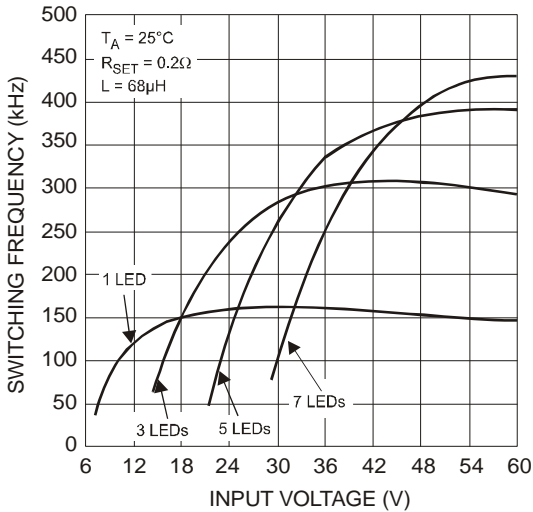

Fig 10. Switching Frequency vs. Input Voltage

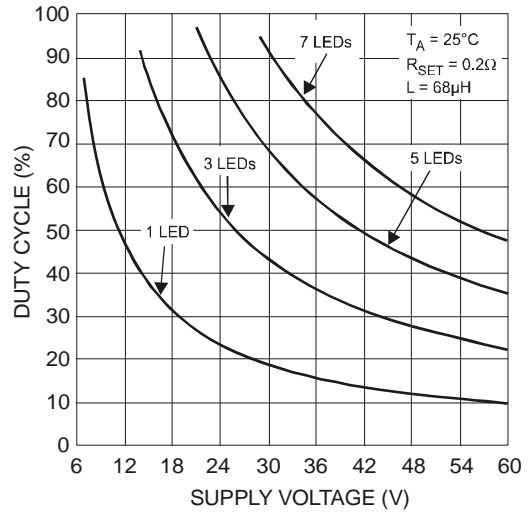

Fig 11. Duty Cycle vs. Input Voltage

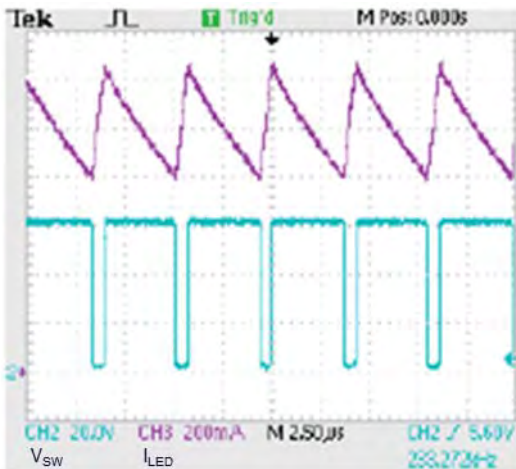

Fig. 12 Steady State Waveforms

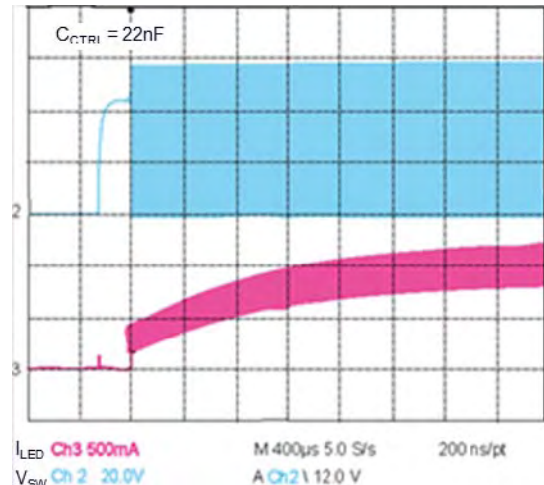

Fig.13 Start-Up Showing LED Current Soft Start

Application Information

LED Current Control

The LED current is controlled by the resistor R_{SET} in Figure 14 connected between V_{IN} and SET. The nominal average output current in the LED(s) with the CTRL pin open circuit is defined as:

$$I_{LED} = \frac{V_{THD}}{R_{SET}} \quad \text{where } V_{THD} \text{ is the voltage between the } V_{IN} \text{ and SET pins and is nominally } 200\text{mV}.$$

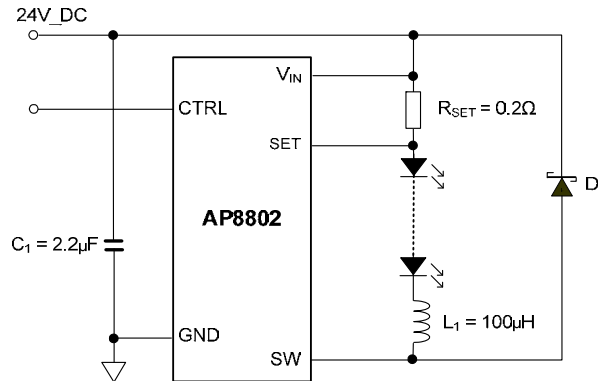

Fig. 14 Typical Application Circuit for $I_{LED} = 1A$

Inductor Selection

This section highlights how to select the inductor suitable for the application requirements in terms of switching frequency, LED current accuracy and temperature.

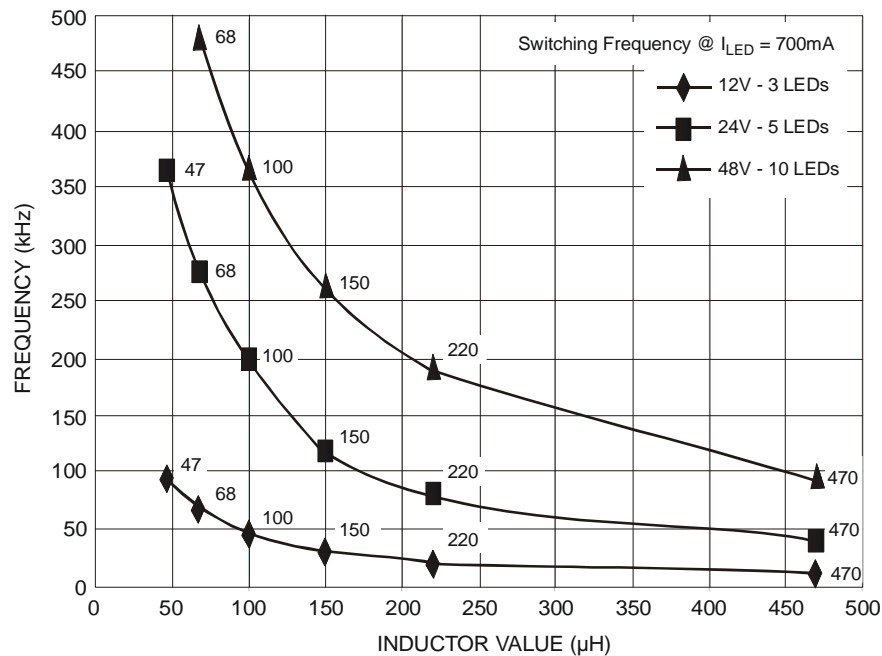

Fig. 15 Switching Frequency vs. Inductor Value

The inductor influences the LED current accuracy that the system is able to provide. The following section highlights how to select the inductor in relation to the device packages and the LED current, while maintaining the chip temperature below 70°C.

Application Information (cont.)

AP8802 U-DFN3030-10 Minimum Recommended Inductor - LED Current 1A
8% Accuracy, <70°C Case Temperature

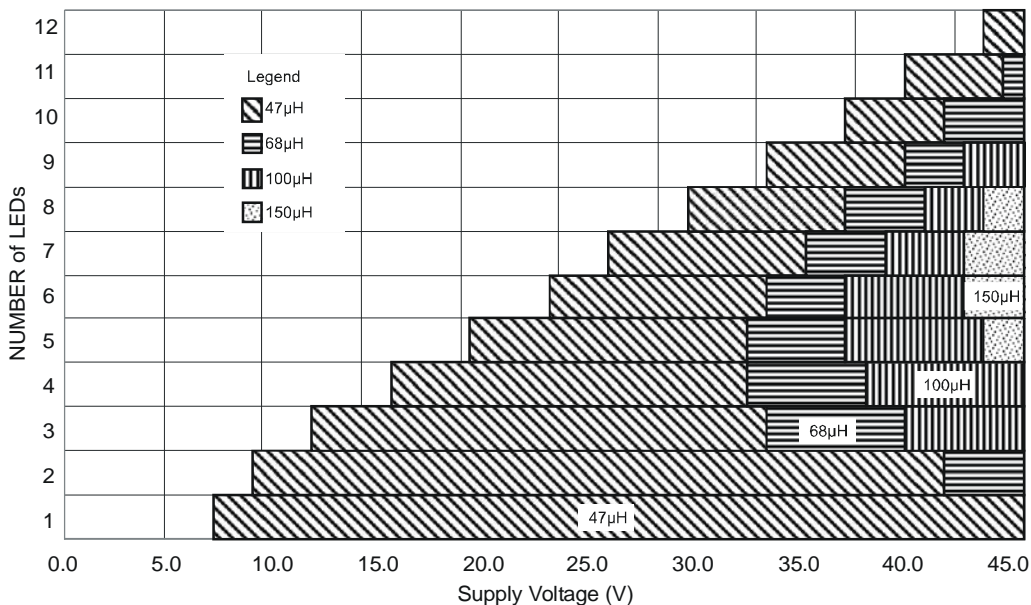

Fig. 16 U-DFN3030-10 Recommended Inductor with 1A LED Current

AP8802 SO-8EP Minimum Recommended Inductor
8% Accuracy, <70°C Case Temperature, 1A Target Current

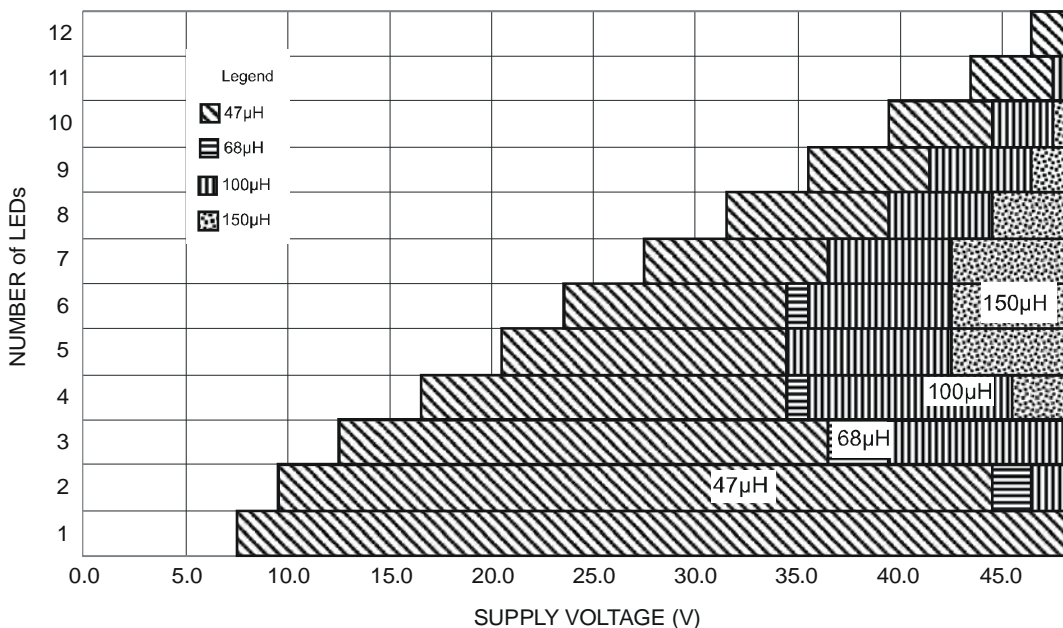

Fig. 17 SO-8EP Recommended Inductor with 1A LED Current

Application Information (cont.)

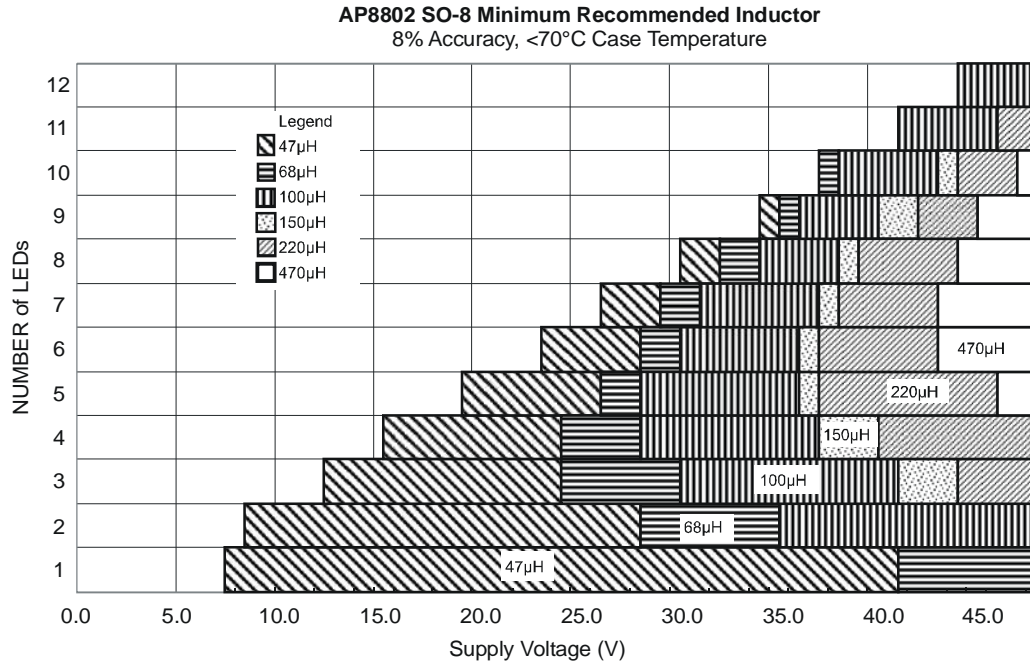

Fig. 18 SO-8 Recommended Inductor with 700mA LED Current

Capacitor Selection

The small size of ceramic capacitors makes them ideal for AP8802 applications. X5R and X7R types are recommended because they retain their capacitance over wider voltage and temperature ranges than other types such as Z5U. A 2.2µF input capacitor is sufficient for most intended applications of AP8802.

A 4.7µF input capacitor is suggested for application with an input voltage equal or higher than 40V.

Diode Selection

Schottky diodes, e.g. B2100 or B1100, with their low forward voltage drop and fast reverse recovery, are the ideal choice for AP8802 applications.

Application Information (cont.)

LED Current Adjustment/Dimming.

The LED current for the AP8802 can be adjusted by driving the CTRL with a digital signal (PWM dimming) or by driving the CTRL with a dc voltage between 0.3V and 2.5V (dc dimming).

If the CTRL pin is driven by an external voltage (lower than 2.5V), the average LED current is:

$$I_{LED} = \frac{V_{CTRL}}{V_{REF}} \times \frac{V_{THD}}{R_{SET}} \quad \text{where } V_{REF} \text{ is nominally } 1.25V$$

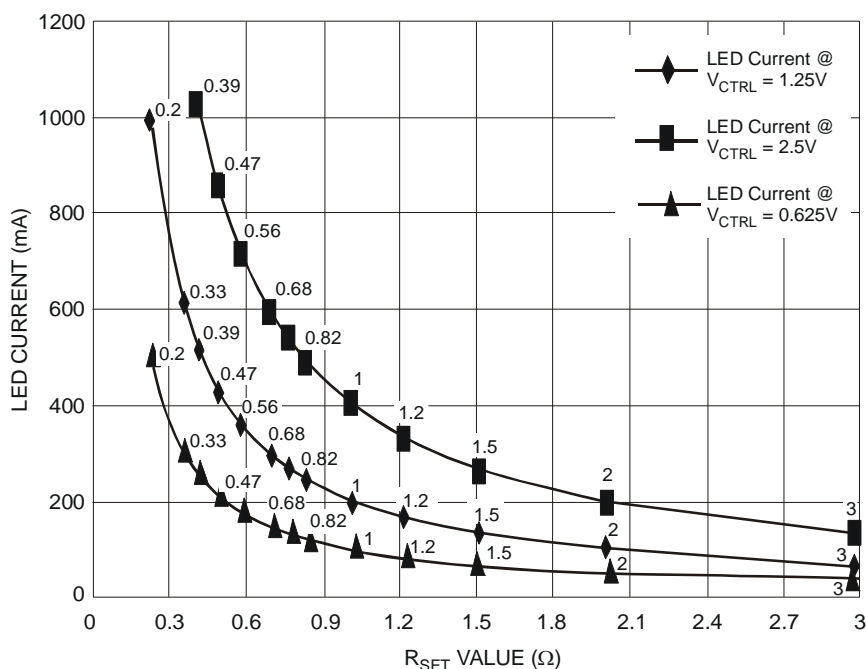

Fig. 19 LED Current Setting vs. R_{SET} and V_{CTRL}

Figure 19 shows that reducing the CTRL voltage by a factor of 2 also reduces the LED current by a factor of 2. The AP8802 has the ability vary the LED current by a factor of 2 above the default value set by RSET down to a factor of 0.24 of the nominal LED current. This provides an 8.33:1 dynamic range of the dc dimming.

A low pass filter on the CTRL pin of the AP8802 automatically provides some soft-start function of the LED current on initial start-up (this phenomenon can be seen in figure 7); the built in soft-start period can be increased by the addition of an external capacitor onto the CTRL pin.

The AP8802's dimming range can be increased above this dc dimming factor by applying a PWM signal to the CTRL pin using this method dimming dynamic ranges above 100 can be achieved.

Application Information (cont.)

PWM Dimming of LED Current

When a low frequency PWM signal with voltages between 2.5V and a low level of zero is applied to the CTRL pin the output current will be switched on and off at the PWM frequency. The resultant LED current I_{LEDavg} will be proportional to the PWM duty cycle. See figure 20.

A Pulse Width Modulated (PWM) signal with a max resolution of 8-bit, can be applied to the CTRL pin to change the output current to a value above or below the nominal average value set by resistor R_{SET} .

To achieve this resolution the PWM frequency has to be lower than 500Hz. The ultimate resolution will be determined by the number of switching cycles required to get back to nominal LED current once the PWM voltage is high relative to PWM frequency. Lower switching frequencies and higher PWM frequencies will result in lower PWM dimming dynamic ranges.

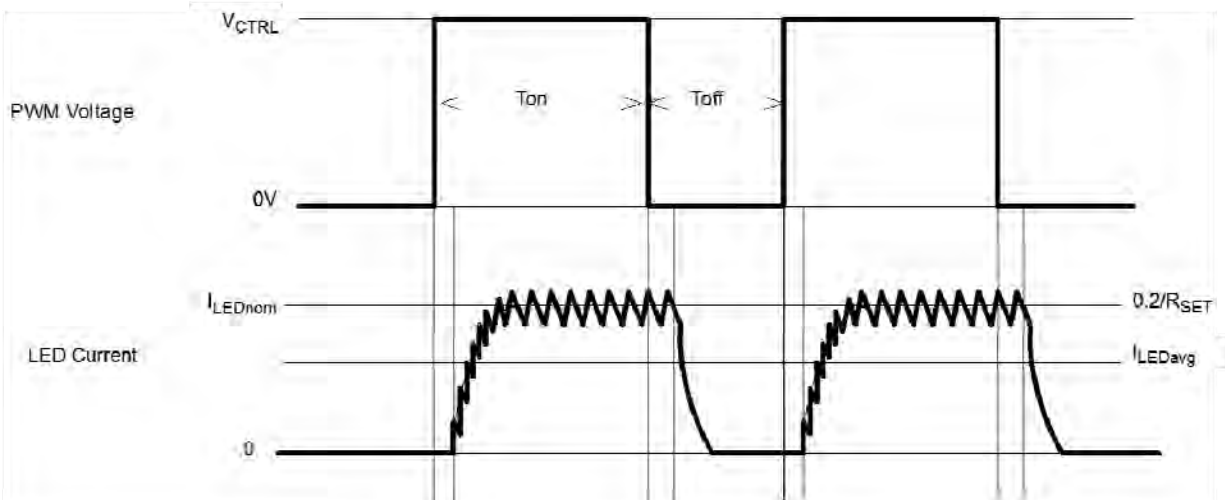

Figure 20. Low Frequency PWM Operating Waveforms

There are different ways of accomplishing PWM dimming of the AP8802 LED current:

Directly Driving CTRL Input

A Pulse Width Modulated (PWM) signal with duty cycle $DPWM$ can be applied to the CTRL pin to adjust the output current to a value above or below the nominal average value set by resistor R_{SET} . When driving the CTRL with a voltage waveform care should be taken not to exceed a drive voltage of 2.5V (where extra brightness is required) or 1.25V if a maximum of 100% brightness is required.

A way of avoiding over-driving the CTRL pin is use an open collector/drain driver to drive the CTRL pin.

Driving the CTRL Input via Open Collector Transistor

The recommended method of driving the CTRL pin and controlling the amplitude of the PWM waveform is to use a small NPN switching transistor. This uses the internal pull-up resistor between the CTRL pin and the internal voltage reference to pull-up CTRL pin when the external transistor is turned off.

Driving the CTRL Input From a Microcontroller

If the CTRL pin is driven by a MOSFET (either discrete or open-drain output of a micro-controller) then Schottky diode maybe be required due to high Gate / Drain capacitance, which could inject a negative spike into CTRL input of the AP8802 and cause erratic operation but the addition of a Schottky clamp diode (eg Diodes Inc. SD103CWS) to ground and inclusion of a series resistor (3.3k) will prevent this.

Application Information (cont.)

Soft-start

An external capacitor from the CTRL pin to ground will provide a soft-start delay, by increasing the time taken for the voltage on this pin to rise to the turn-on threshold and by slowing down the rate of rise of the control voltage at the input of the comparator. Adding capacitance increases this delay by approximately 200 μ s/nF. The graph below shows the variation of soft-start time for different values of capacitor.

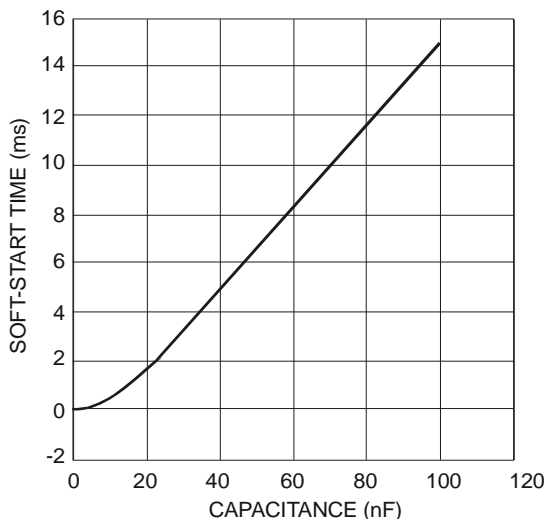
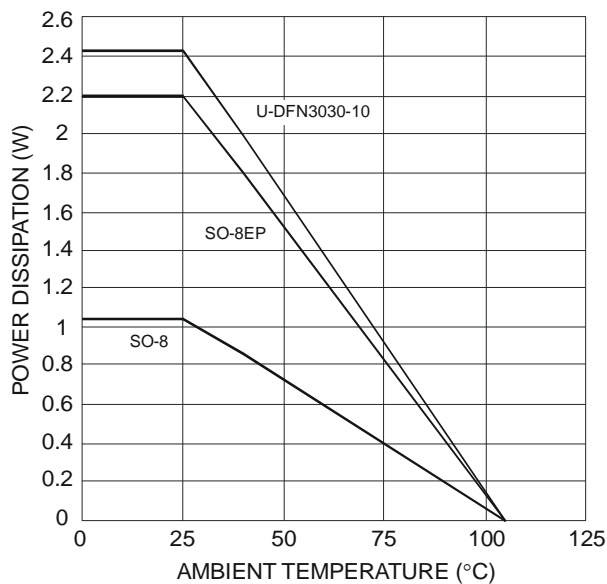

Fig. 21 Soft-Start Time vs. Capacitance from ADJ Pin to Ground

Thermal Considerations

The graph below in figure 22, gives details for power derating. This assumes the device to be mounted on a 25x25mm PCB with 1oz copper standing in still air.



Maximum Power Dissipation
Fig. 22 AP8802 Derating Curves

Application Information (cont.)

Package Selection

The device comes with a wide selection of packages. The suggested package is able to provide a case temperature below 70°C (with an ambient temperature of 25°C) for the combination of input voltage and load requested.

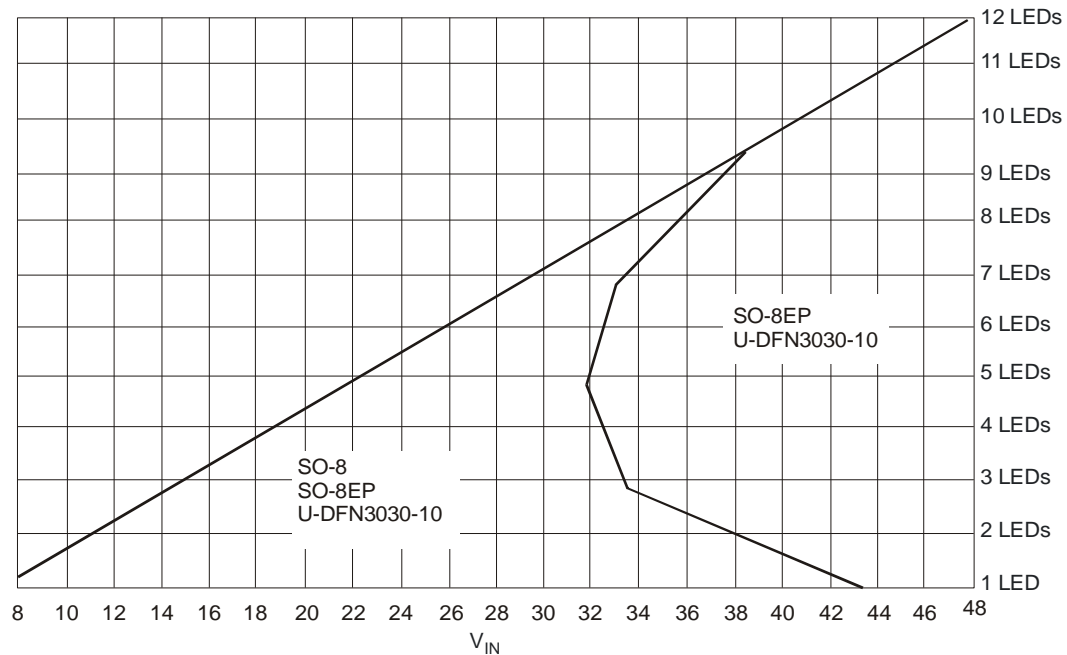
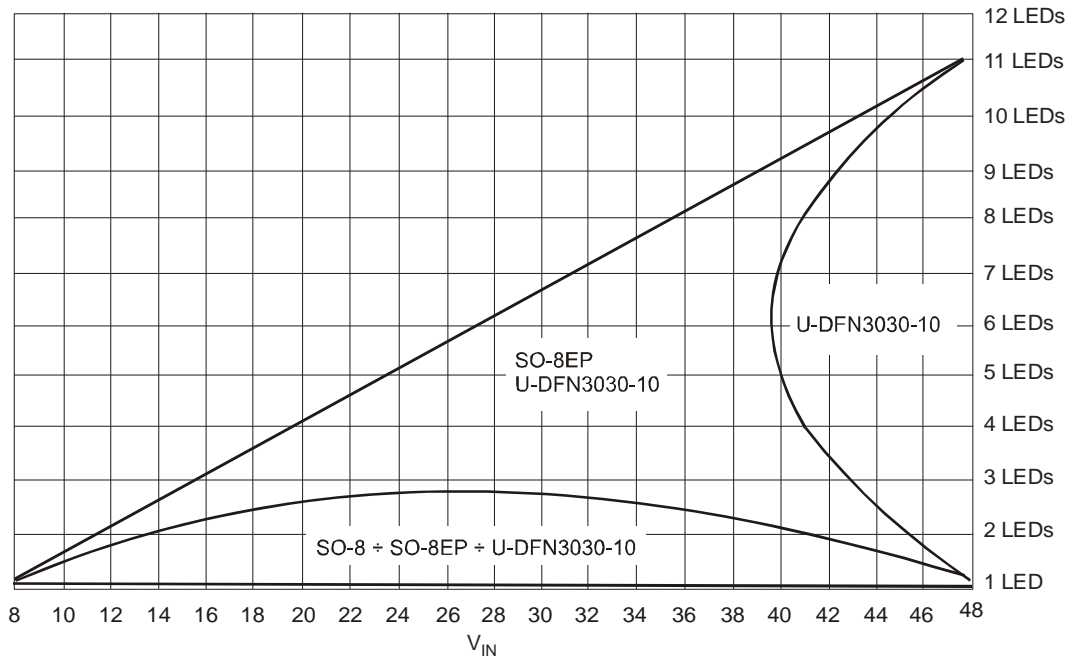

Applications Information (cont.)

Fault Condition Operation

The AP8802 has by default open LED protection. If the LEDs should become open circuit the AP8802 will stop oscillating; the SET pin will rise to V_{IN} and the SW pin will then fall to GND. No excessive voltages will be seen by the AP8802.

If the LEDs should become shorted together the AP8802H will continue to switch however the duty cycle at which it will operate will change dramatically and the switching frequency will most likely decrease. The on-time of the internal power MOSFET switch will be significantly reduced because almost all of the input voltage is now developed across the inductor. The off-time will be significantly increased because the reverse voltage across the inductor is now just the Schottky diode voltage (See Figure 20) causing a much slower decay in inductor current. During this condition the inductor current will remain within its controlled levels and so no excessive heat will be generated within the AP8802.

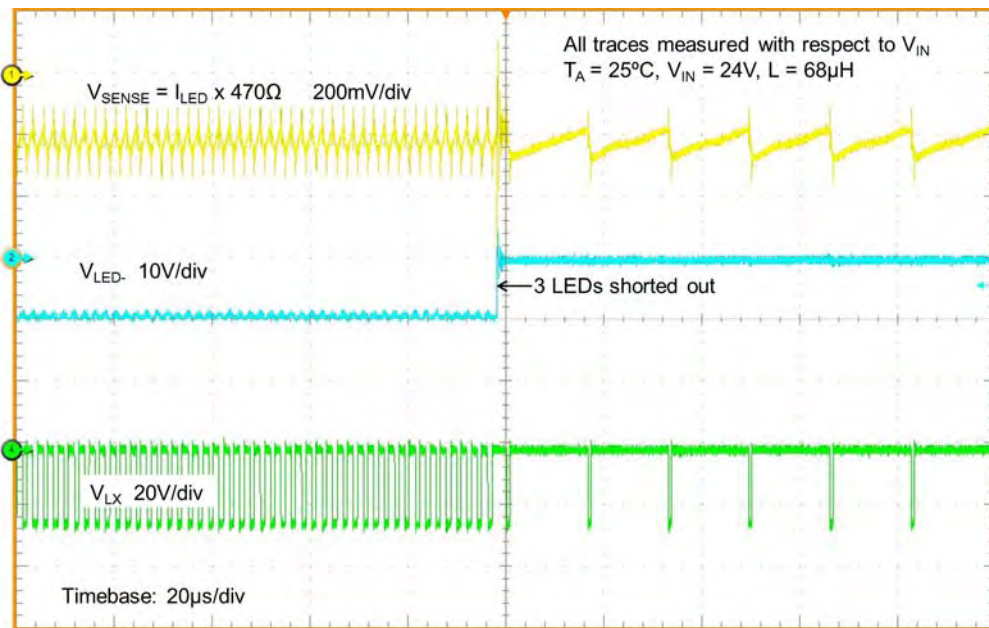
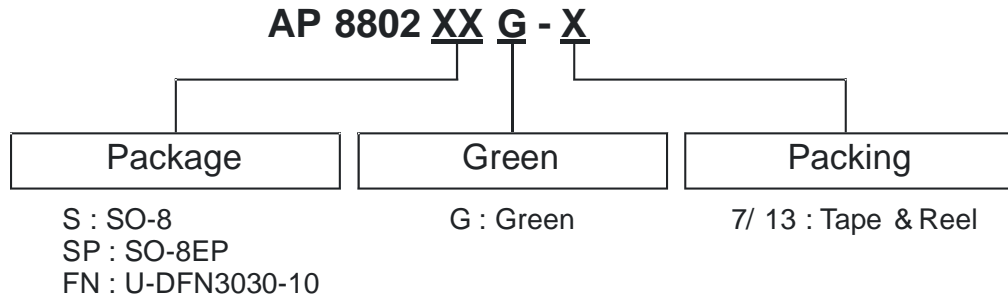

Fig. 24 Switching Characteristics (normal open to short LED chain)

Ordering Information



Device	Package Code	Packaging (Note 7)	7"/13" Tape and Reel	
			Quantity	Part Number Suffix
AP8802SG-13	S	SO-8	2500/Tape & Reel	-13
AP8802SPG-13	SP	SO-8EP	2500/Tape & Reel	-13
AP8802FNG-7	FN	U-DFN3030-10	3000/Tape & Reel	-7



Notes: 7. Pad layout as shown on Diodes Inc. suggested pad layout document AP02001, which can be found on our website at <http://www.diodes.com/datasheets/ap02001.pdf>.

Marking Information

(1) SO-8

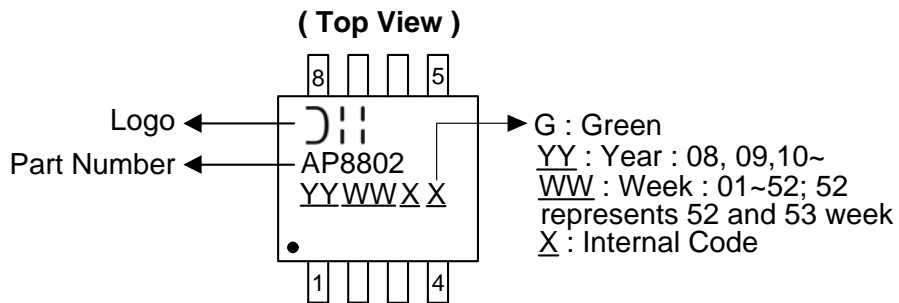

(2) SO-8EP

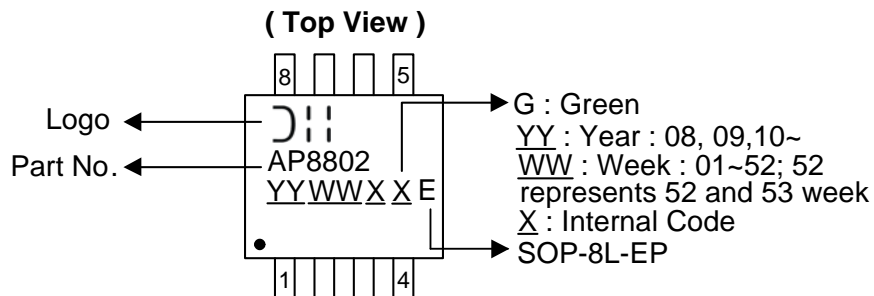

Marking Information (cont.)

(3) U-DFN3030-10

(Top View)

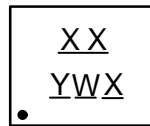

XX : Identification Code
Y : Year : 0~9
W : Week : A~Z : 1~26 week;
a~z : 27~52 week; z represents
52 and 53 week
X : A~Z : Green

Part Number	Package	Identification Code
AP8802FNG-7	U-DFN3030-10	A5

Package Outline Dimensions (All Dimensions in mm)

(1) Package Type: SO-8

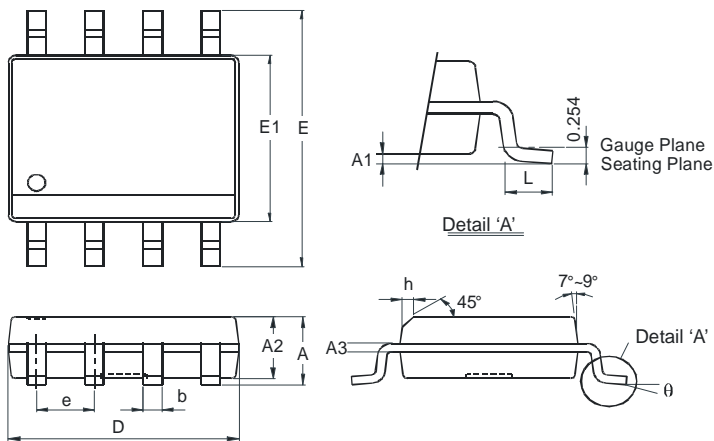

SO-8		
Dim	Min	Max
A	-	1.75
A1	0.10	0.20
A2	1.30	1.50
A3	0.15	0.25
b	0.3	0.5
D	4.85	4.95
E	5.90	6.10
E1	3.85	3.95
e	1.27 Typ	
h	-	0.35
L	0.62	0.82
θ	0°	8°
All Dimensions in mm		

Package Outline Dimensions (cont.) (All Dimensions in mm)

(2) Package Type: SO-8EP

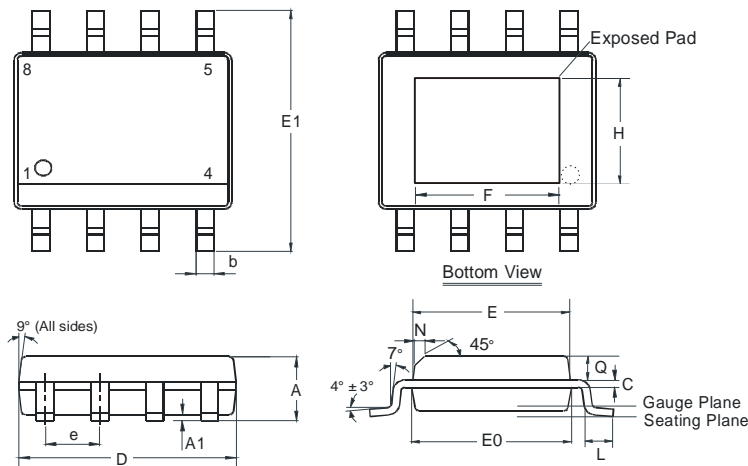

SO-8EP (SOP-8L-EP)			
Dim	Min	Max	Typ
A	1.40	1.50	1.45
A1	0.00	0.13	-
b	0.30	0.50	0.40
C	0.15	0.25	0.20
D	4.85	4.95	4.90
E	3.80	3.90	3.85
E0	3.85	3.95	3.90
E1	5.90	6.10	6.00
e	-	-	1.27
F	2.75	3.35	3.05
H	2.11	2.71	2.41
L	0.62	0.82	0.72
N	-	-	0.35
Q	0.60	0.70	0.65
All Dimensions in mm			

(3) Package Type: U-DFN3030-10

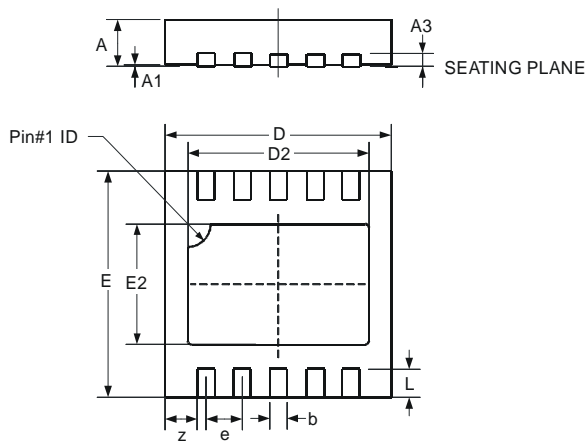

U-DFN3030-10			
Dim	Min	Max	Typ
A	0.57	0.63	0.60
A1	0	0.05	0.02
A3	—	—	0.15
b	0.20	0.30	0.25
D	2.90	3.10	3.00
D2	2.30	2.50	2.40
e	—	—	0.50
E	2.90	3.10	3.00
E2	1.50	1.70	1.60
L	0.25	0.55	0.40
z	—	—	0.375
All Dimensions in mm			

Suggested Pad Layout

(1) Package Type: SO-8

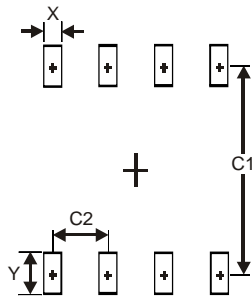

Dimensions	Value (in mm)
X	0.60
Y	1.55
C1	5.4
C2	1.27

(2) Package Type: SO-8EP

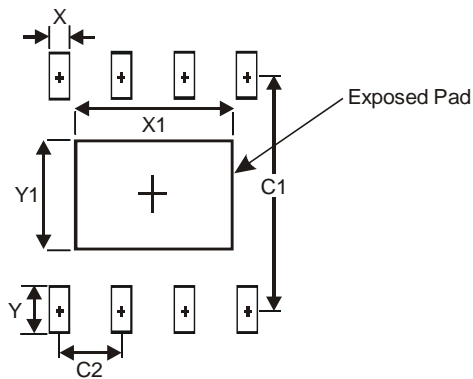

Dimensions	Value (in mm)
X	0.60
Y	1.55
X1	3.30
Y1	2.66
C1	5.4
C2	1.27

(3) Package Type: U-DFN3030-10

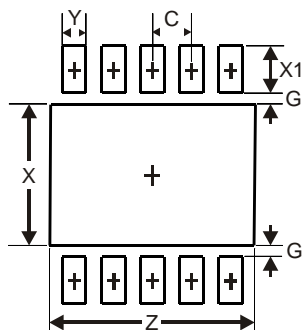

Dimensions	Value (in mm)
Z	2.60
G	0.15
X	1.80
X1	0.60
Y	0.30
C	0.50

IMPORTANT NOTICE

DIODES INCORPORATED MAKES NO WARRANTY OF ANY KIND, EXPRESS OR IMPLIED, WITH REGARDS TO THIS DOCUMENT, INCLUDING, BUT NOT LIMITED TO, THE IMPLIED WARRANTIES OF MERCHANTABILITY AND FITNESS FOR A PARTICULAR PURPOSE (AND THEIR EQUIVALENTS UNDER THE LAWS OF ANY JURISDICTION).

Diodes Incorporated and its subsidiaries reserve the right to make modifications, enhancements, improvements, corrections or other changes without further notice to this document and any product described herein. Diodes Incorporated does not assume any liability arising out of the application or use of this document or any product described herein; neither does Diodes Incorporated convey any license under its patent or trademark rights, nor the rights of others. Any Customer or user of this document or products described herein in such applications shall assume all risks of such use and will agree to hold Diodes Incorporated and all the companies whose products are represented on Diodes Incorporated website, harmless against all damages.

Diodes Incorporated does not warrant or accept any liability whatsoever in respect of any products purchased through unauthorized sales channel.

Should Customers purchase or use Diodes Incorporated products for any unintended or unauthorized application, Customers shall indemnify and hold Diodes Incorporated and its representatives harmless against all claims, damages, expenses, and attorney fees arising out of, directly or indirectly, any claim of personal injury or death associated with such unintended or unauthorized application.

Products described herein may be covered by one or more United States, international or foreign patents pending. Product names and markings noted herein may also be covered by one or more United States, international or foreign trademarks.

LIFE SUPPORT

Diodes Incorporated products are specifically not authorized for use as critical components in life support devices or systems without the express written approval of the Chief Executive Officer of Diodes Incorporated. As used herein:

A. Life support devices or systems are devices or systems which:

1. are intended to implant into the body, or
2. support or sustain life and whose failure to perform when properly used in accordance with instructions for use provided in the labeling can be reasonably expected to result in significant injury to the user.

B. A critical component is any component in a life support device or system whose failure to perform can be reasonably expected to cause the failure of the life support device or to affect its safety or effectiveness.

Customers represent that they have all necessary expertise in the safety and regulatory ramifications of their life support devices or systems, and acknowledge and agree that they are solely responsible for all legal, regulatory and safety-related requirements concerning their products and any use of Diodes Incorporated products in such safety-critical, life support devices or systems, notwithstanding any devices- or systems-related information or support that may be provided by Diodes Incorporated. Further, Customers must fully indemnify Diodes Incorporated and its representatives against any damages arising out of the use of Diodes Incorporated products in such safety-critical, life support devices or systems.

Copyright © 2012, Diodes Incorporated

www.diodes.com