

# 1.5A/4.1A Multiple LED Camera Flash Driver With I<sup>2</sup>C™ Compatible Interface

 Check for Samples: [TPS61300](#), [TPS61301](#), [TPS61305](#)

## FEATURES

- **Four Operational Modes**
  - DC Light and Flashlight
  - Voltage Regulated Converter: 3.8V...5.7V
  - Standby: 2µA (typ.)
- **Storage Capacitor Friendly Solution**
- **Automatic V<sub>F</sub> and ESR Calibration**
- **Power-Save Mode for Improved Efficiency at Low Output Power, Up to 95% Efficiency**
- **Output Voltage Remains Regulated When Input Voltage Exceeds Nominal Output Voltage**
- **I<sup>2</sup>C Compatible Interface up to 3.4Mbits/s**
- **Zero Latency Tx-Masking Input**
- **Hardware Voltage Mode Selection Input (TPS61300, TPS61301)**
- **DC Light Mode Selection Input (TPS61300, TPS61306)**
- **Hardware Reset Input (TPS61301, TPS61305)**
- **LED Temperature Monitoring (TPS61305)**
- **Privacy Indicator LED Output**
- **Integrated LED Safety Timer**
- **Total Solution Size of Less Than 25 mm<sup>2</sup> (<1mm height)**
- **Available in a 20-Pin NanoFree™ (CSP)**

## APPLICATIONS

- **Single/Dual/Triple White LED Flashlight Supply for Cell Phones and Smart-Phones**
- **LED Based Xenon "Killer" Flashlight**
- **Audio Amplifier Power Supply**

## DESCRIPTION

The TPS6130x device is based on a high-frequency synchronous boost topology with constant current sinks to drive up to three white LEDs in parallel (400mA/800mA/400mA maximum flash current). **The extended high-current mode (HC\_SEL) allows up to 1025mA/2050mA/1025mA flash current out of the storage capacitor.**

The high-capacity storage capacitor on the output of the boost regulator provides the high-peak flash LED current, thereby reducing the peak current demand from the battery to a minimum.

The 2-MHz switching frequency allows the use of small and low profile 2.2µH inductors. To optimize overall efficiency, the device operates with a 400mV LED feedback voltage.

The TPS6130x device not only operates as a regulated current source, but also as a standard voltage boost regulator. The device keeps the output voltage regulated even when the input voltage exceeds the nominal output voltage. The device enters power-save mode operation at light load currents to maintain high efficiency over the entire load current range.

To simplify flashlight synchronization with the camera module, the device offers a trigger pin (FLASH\_SYNC) for zero latency LED turn-on time.

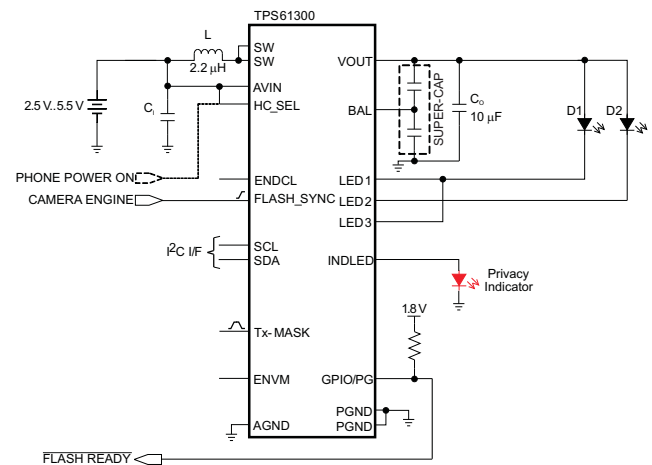

**Figure 1. Typical Application**



Please be aware that an important notice concerning availability, standard warranty, and use in critical applications of Texas Instruments semiconductor products and disclaimers thereto appears at the end of this data sheet.

NanoFree is a trademark of Texas Instruments.

I<sup>2</sup>C is a trademark of NXP Semiconductors.

PRODUCTION DATA information is current as of publication date. Products conform to specifications per the terms of the Texas Instruments standard warranty. Production processing does not necessarily include testing of all parameters.



This integrated circuit can be damaged by ESD. Texas Instruments recommends that all integrated circuits be handled with appropriate precautions. Failure to observe proper handling and installation procedures can cause damage.

ESD damage can range from subtle performance degradation to complete device failure. Precision integrated circuits may be more susceptible to damage because very small parametric changes could cause the device not to meet its published specifications.

**AVAILABLE OPTIONS**

PART NUMBER <sup>(1)</sup>	PACKAGE MARKING	PACKAGE	DEVICE SPECIFIC FEATURES <sup>(2)</sup>
TPS61300YFF	TPS61300	CSP-20	Hardware Enable DC Light Input (ENDCL)
TPS61301YFF	TPS61301	CSP-20	Hardware Enable / Disable Input (NRESET)
TPS61305YFF	TPS61305	CSP-20	Hardware Enable / Disable Input (NRESET) LED Temperature Monitoring Input (TS)
TPS61306YFF <sup>(3)</sup>	TPS61306	CSP-20	Hardware Enable DC Light Input (ENDCL) LED Temperature Monitoring Input (TS)

- (1) The YFF package is available in tape and reel. Add R suffix (TPS6130xYFFR) to order quantities of 3000 parts per reel, T suffix for 250 parts per reel.
- (2) For more details, refer to the section *Application Diagrams*.
- (3) Device status is Product Preview. Please contact TI for more details.

**ABSOLUTE MAXIMUM RATINGS**

over operating free-air temperature range (unless otherwise noted) <sup>(1)</sup>

		VALUE	UNIT
V <sub>I</sub>	Voltage range on AVIN, VOUT, SW, LED1, LED2, LED3 <sup>(2)</sup>	-0.3 to 7	V
	Voltage range on SCL, SDA, FLASH_SYNC, ENDCL, NRESET, ENVN, GPIO/PG <sup>(2)</sup>	-0.3 to 7	V
	Voltage range on HC_SEL, Tx-MASK, TS, BAL <sup>(2)</sup>	-0.3 to 7	V
	Current on GPIO/PG	±25	mA
	Power dissipation	Internally limited	
T <sub>A</sub> <sup>(3)</sup>	Operating ambient temperature range	-40 to 85	°C
T <sub>J (MAX)</sub>	Maximum operating junction temperature	150	°C
T <sub>stg</sub>	Storage temperature range	-65 to 150	°C
ESD rating <sup>(4)</sup>	Human body model	2	kV
	Charge device model	500	V
	Machine model	100	V

- (1) Stresses beyond those listed under *absolute maximum ratings* may cause permanent damage to the device. These are stress ratings only, and functional operation of the device at these or any other conditions beyond those indicated under *recommended operating conditions* is not implied. Exposure to absolute–maximum–rated conditions for extended periods may affect device reliability.
- (2) All voltage values are with respect to network ground terminal.
- (3) In applications where high power dissipation and/or poor package thermal resistance is present, the maximum ambient temperature may have to be derated. Maximum ambient temperature [T<sub>A(max)</sub>] is dependent on the maximum operating junction temperature [T<sub>J(max)</sub>], the maximum power dissipation of the device in the application [P<sub>D(max)</sub>], and the junction-to-ambient thermal resistance of the part/package in the application (θ<sub>JA</sub>), as given by the following equation: T<sub>A(max)</sub> = T<sub>J(max)</sub> - (θ<sub>JA</sub> × P<sub>D(max)</sub>)
- (4) The human body model is a 100-pF capacitor discharged through a 1.5-kΩ resistor into each pin. The machine model is a 200-pF capacitor discharged directly into each pin.

**DISSIPATION RATINGS**

PACKAGE	THERMAL RESISTANCE <sup>(1)</sup> θ <sub>JA</sub>	THERMAL RESISTANCE <sup>(1)</sup> θ <sub>JB</sub>	POWER RATING T <sub>A</sub> = 25°C	DERATING FACTOR ABOVE <sup>(2)</sup> T <sub>A</sub> = 25°C
YFF	71°C/W	21°C/W	1.4 W	14mW/°C

- (1) Simulated with high-K board
- (2) Maximum power dissipation is a function of T<sub>J(max)</sub>, θ<sub>JA</sub> and T<sub>A</sub>. The maximum allowable power dissipation at any allowable ambient temperature is P<sub>D</sub> = (T<sub>J(max)</sub> - T<sub>A</sub>) / θ<sub>JA</sub>.

## ELECTRICAL CHARACTERISTICS

Unless otherwise noted the specification applies for  $V_{IN} = 3.6V$  over an operating junction temp.  $-40^{\circ}C \leq T_J \leq 125^{\circ}C$ ; Circuit of Parameter Measurement Information section (unless otherwise noted). Typical values are for  $T_J = 25^{\circ}C$ .

PARAMETER		TEST CONDITIONS	MIN	TYP	MAX	UNIT
<b>SUPPLY CURRENT</b>						
$V_{IN}$	Input voltage range		2.5		5.5	V
$I_Q$	Operating quiescent current into AVIN	$I_{OUT} = 0$ mA, device not switching $-40^{\circ}C \leq T_J \leq +85^{\circ}C$		590	700	$\mu A$
		$I_{OUT(DC)} = 0$ mA, PWM operation $V_{OUT} = 4.95V$ , voltage regulation mode		11.3		mA
$I_{SD}$	Shutdown current	HC_SEL = 0, $-40^{\circ}C \leq T_J \leq +85^{\circ}C$		1	5	$\mu A$
$I_{STBY}$	Standby current	HC_SEL = 1, storage capacitor balanced $-40^{\circ}C \leq T_J \leq +85^{\circ}C$		2	12	$\mu A$
		Pre-charge current	$V_{OUT} = 2.3V, 2.5V \leq V_{IN} \leq 5.5V$	150		mA
	Pre-charge hysteresis (referred to $V_{OUT}$ )		40	75		mV
$V_{UVLO}$	Undervoltage lockout threshold (analog circuitry)	$V_{IN}$ falling		2.3	2.4	V
<b>OUTPUT</b>						
$V_{OUT}$	Output voltage range	Current regulation mode	$V_{IN}$		5.5	V
		Voltage regulation mode	3.825		5.7	V
	Internal feedback voltage accuracy	$2.5V \leq V_{IN} \leq 4.8V, -20^{\circ}C \leq T_J \leq +125^{\circ}C$ Boost mode, PWM voltage regulation	-2%		2%	
	Power-save mode ripple voltage	$I_{OUT} = 10$ mA		0.015 $V_{OUT}$		$V_{P-P}$
OVP	Output overvoltage protection	$V_{OUT}$ rising, $0000 \leq OV[3:0] \leq 0100$	4.5	4.65	4.8	V
		$V_{OUT}$ rising, $0101 \leq OV[3:0] \leq 1111$	5.8	6.0	6.2	V
	Output overvoltage protection hysteresis	$V_{OUT}$ falling, $0101 \leq OV[3:0] \leq 1111$		0.15		V
<b>POWER SWITCH</b>						
$r_{DS(on)}$	Switch MOSFET on-resistance	$V_{OUT} = V_{GS} = 3.6$ V		90		m $\Omega$
	Rectifier MOSFET on-resistance	$V_{OUT} = V_{GS} = 3.6$ V		135		m $\Omega$
$I_{lkg(SW)}$	Leakage into SW	$V_{OUT} = 0V, SW = 3.6V, -40^{\circ}C \leq T_J \leq +85^{\circ}C$		0.3	4	$\mu A$
$I_{lim}$	Rectifier valley current limit (open-loop)	$V_{OUT} = 4.95V, HC\_SEL = 0$ $-20^{\circ}C \leq T_J \leq +85^{\circ}C$ PWM operation, relative to selected ILIM	-15		+15	%
<b>OSCILLATOR</b>						
$f_{OSC}$	Oscillator frequency			1.92		MHz
$f_{ACC}$	Oscillator frequency		-10		+7	%
<b>THERMAL SHUTDOWN, HOT DIE DETECTOR</b>						
	Thermal shutdown <sup>(1)</sup>		140	160		$^{\circ}C$
	Thermal shutdown hysteresis <sup>(1)</sup>			20		$^{\circ}C$
	Hot die detector accuracy <sup>(1)</sup>		-8		8	$^{\circ}C$

(1) Verified by characterization. Not tested in production.

**ELECTRICAL CHARACTERISTICS (Continued)**

Unless otherwise noted the specification applies for  $V_{IN} = 3.6V$  over an operating junction temp.  $-40^{\circ}C \leq T_J \leq 125^{\circ}C$ ; Circuit of Parameter Measurement Information section (unless otherwise noted). Typical values are for  $T_J = 25^{\circ}C$ .

PARAMETER		TEST CONDITIONS	MIN	TYP	MAX	UNIT	
<b>LED CURRENT REGULATOR</b>							
LED1/3 current accuracy <sup>(1)</sup>	HC_SEL = 0	$0.4V \leq V_{LED1/3} \leq 2.0V$ $00 \leq DCLC13[1:0] \leq 11, T_J = +85^{\circ}C$	-10		+10	%	
		$0.4V \leq V_{LED1/3} \leq 2.0V$ $00 \leq FC13[1:0] \leq 11, T_J = +85^{\circ}C$	-7.5		+7.5	%	
LED2 current accuracy <sup>(1)</sup>	HC_SEL = 0	$0.4V \leq V_{LED2} \leq 2.0V$ $000 \leq DCLC2[2:0] \leq 111, T_J = +85^{\circ}C$	-10		+10	%	
		$0.4V \leq V_{LED2} \leq 2.0V$ $000 \leq FC2[2:0] \leq 111, T_J = +85^{\circ}C$	-7.5		+7.5	%	
LED1/3 current accuracy <sup>(1)</sup>	HC_SEL = 1	$0.4V \leq V_{LED1/3} \leq 2.0V$ $00 \leq DCLC13[1:0] \leq 11, T_J = +85^{\circ}C$	-10		+10	%	
		$0.4V \leq V_{LED1/3} \leq 2.0V$ $00 \leq FC13[1:0] \leq 11, T_J = +85^{\circ}C$	-10		+10	%	
LED2 current accuracy <sup>(1)</sup>	HC_SEL = 1	$0.4V \leq V_{LED2} \leq 2.0V$ $000 \leq DCLC2[2:0] \leq 111, T_J = +85^{\circ}C$	-10		+10	%	
		$0.4V \leq V_{LED1/3} \leq 2.0V$ $000 \leq FC2[2:0] \leq 111, T_J = +85^{\circ}C$	-10		+10	%	
LED1/3 current matching <sup>(1)</sup>			-10		+10	%	
LED1/2/3 current temperature coefficient				0.05		%/°C	
INDLED current accuracy		$1.5V \leq (V_{IN}-V_{INDLED}) \leq 2.5V$ $2.6mA \leq I_{INDLED} \leq 7.9mA$ $T_J = +25^{\circ}C$	-20		+20	%	
INDLED current temperature coefficient				0.04		%/°C	
V <sub>DO</sub>	LED1/2/3 sense voltage		I <sub>LED1-3</sub> = full-scale current, HC_SEL = 0		400	mV	
	LED1/2/3 sense voltage		I <sub>LED1-3</sub> = full-scale current, HC_SEL = 1		400	450	mV
	VOUT dropout voltage		I <sub>OUT</sub> = -7.5mA, device not switching			220	mV
	LED1/2/3 input leakage current		V <sub>LED1/2/3</sub> = V <sub>OUT</sub> = 5V, $-40^{\circ}C \leq T_J \leq +85^{\circ}C$		0.1	4	µA
INDLED input leakage current		V <sub>INDLED</sub> = 0V, $-40^{\circ}C \leq T_J \leq +85^{\circ}C$		0.1	1	µA	

(1) Verified by characterization. Not tested in production.

## ELECTRICAL CHARACTERISTICS

Unless otherwise noted the specification applies for  $V_{IN} = 3.6V$  over an operating junction temp.  $-40^{\circ}C \leq T_J \leq 125^{\circ}C$ ; Circuit of Parameter Measurement Information section (unless otherwise noted). Typical values are for  $T_J = 25^{\circ}C$ .

PARAMETER		TEST CONDITIONS	MIN	TYP	MAX	UNIT
<b>STORAGE CAPACITOR ACTIVE CELL BALANCING</b>						
Active cell balancing circuitry quiescent current into VOUT		HC_SEL = 1, storage capacitor balanced $-40^{\circ}C \leq T_J \leq +85^{\circ}C$		1.7	3.0	$\mu A$
Active cell balancing accuracy		(VOUT – BAL) vs. BAL voltage difference Storage capacitor balanced HC_SEL = 1 VOUT = 5.7V	-100		100	mV
BAL output drive capability		VOUT = 4.95V, Sink and source current	$\pm 10$	$\pm 15$		mA
Active discharge resistor		HC_SEL = 0, device in shutdown mode VOUT to BAL and BAL to GND		0.85	1.5	k $\Omega$
<b>LED TEMPERATURE MONITORING (TPS61305)</b>						
$I_{O(TS)}$	Temperature Sense Current Source	Thermistor bias current		23.8		$\mu A$
	TS Resistance (Warning Temperature)	LEDWARN bit = 1, $T_J \geq 25^{\circ}C$	39	44.5	50	k $\Omega$
	TS Resistance (Hot Temperature)	LEDHOT bit = 1, $T_J \geq 25^{\circ}C$	12.5	14.5	16.5	k $\Omega$
<b>SDA, SCL, GPIO/PG, ENVM, Tx-MASK, ENDCL, NRESET, FLASH_SYNC, HC_SEL</b>						
$V_{(IH)}$	High-level input voltage		1.2			V
$V_{(IL)}$	Low-level input voltage				0.4	V
$V_{(OL)}$	Low-level output voltage (SDA)	$I_{OL} = 8mA$			0.3	V
	Low-level output voltage (GPIO)	DIR = 1, $I_{OL} = 5mA$			0.3	V
$V_{(OH)}$	High-level output voltage (GPIO)	DIR = 1, GPIOTYPE = 0, $I_{OH} = 8mA$	$V_{IN}-0.4$			V
$I_{(LKG)}$	Logic input leakage current	Input connected to VIN or GND $-40^{\circ}C \leq T_J \leq +85^{\circ}C$		0.01	0.1	$\mu A$
$R_{PD}$	ENVM pull-down resistance	$ENVM \leq 0.4 V$		350		k $\Omega$
	ENDCL, NRESET pull-down resistance	$ENDCL, NRESET \leq 0.4 V$		350		k $\Omega$
	FLASH_SYNC pull-down resistance	$FLASH\_SYNC \leq 0.4 V$		350		k $\Omega$
	Tx-MASK pull-down resistance	$Tx-MASK \leq 0.4 V$		350		k $\Omega$
	HC_SEL pull-down resistance	$HC\_SEL \leq 0.4 V$		350		k $\Omega$
$C_{(IN)}$	SDA Input Capacitance	SDA = VIN or GND		9		pF
	SCL Input Capacitance	SCL = VIN or GND		4		pF
	GPIO/PG Input Capacitance	DIR = 0, GPIO/PG = VIN or GND		9		pF
	ENVM Input Capacitance	$ENVM = VIN$ or GND		4		pF
	ENDCL Input Capacitance	$ENDCL = VIN$ or GND		3		pF
	HC_SEL Input Capacitance	$HC\_SEL = VIN$ or GND		3.5		pF
	Tx-MASK Input Capacitance	$Tx-MASK = VIN$ or GND		4		pF
FLASH_SYNC Input Capacitance	$FLASH\_SYNC = VIN$ or GND		3		pF	

**ELECTRICAL CHARACTERISTICS (continued)**

Unless otherwise noted the specification applies for  $V_{IN} = 3.6V$  over an operating junction temp.  $-40^{\circ}C \leq T_J \leq 125^{\circ}C$ ; Circuit of Parameter Measurement Information section (unless otherwise noted). Typical values are for  $T_J = 25^{\circ}C$ .

PARAMETER		TEST CONDITIONS	MIN	TYP	MAX	UNIT
<b>TIMING</b>						
$t_{NRESET}$	Reset pulse width		10			$\mu s$
	Start-up time	From shutdown into DC light mode HC_SEL = 0, $I_{LED} = 100mA$		1.4		ms
		From shutdown into voltage mode via ENVN HC_SEL = 0, $I_{OUT} = 0mA$		550		$\mu s$
	LED current settling time <sup>(1)</sup> triggered by a rising edge on FLASH_SYNC	MODE_CTRL[1:0] = 10, HC_SEL = 0 $I_{LED2} = \text{from } 0mA \text{ to } 800mA$		400		$\mu s$
		MODE_CTRL[1:0] = 10, HC_SEL = 1 $I_{LED2} = \text{from } 0mA \text{ to } 1800mA$		16		$\mu s$
	LED current settling time <sup>(1)</sup> triggered by Tx-MASK	MODE_CTRL[1:0] = 10, HC_SEL = 0 $I_{LED2} = \text{from } 800mA \text{ to } 350mA$		15		$\mu s$

(1) Settling time to  $\pm 15\%$  of the target value.

**I<sup>2</sup>C INTERFACE TIMING CHARACTERISTICS<sup>(1)</sup>**

PARAMETER		TEST CONDITIONS	MIN	MAX	UNIT
$f_{(SCL)}$	SCL Clock Frequency	Standard mode		100	kHz
		Fast mode		400	kHz
		High-speed mode (write operation), $C_B - 100 pF \text{ max}$		3.4	MHz
		High-speed mode (read operation), $C_B - 100 pF \text{ max}$		3.4	MHz
		High-speed mode (write operation), $C_B - 400 pF \text{ max}$		1.7	MHz
		High-speed mode (read operation), $C_B - 400 pF \text{ max}$		1.7	MHz
$t_{BUF}$	Bus Free Time Between a STOP and START Condition	Standard mode	4.7		$\mu s$
		Fast mode	1.3		$\mu s$
$t_{HD}, t_{STA}$	Hold Time (Repeated) START Condition	Standard mode	4		$\mu s$
		Fast mode	600		ns
		High-speed mode	160		ns
$t_{LOW}$	LOW Period of the SCL Clock	Standard mode	4.7		$\mu s$
		Fast mode	1.3		$\mu s$
		High-speed mode, $C_B - 100 pF \text{ max}$	160		ns
		High-speed mode, $C_B - 400 pF \text{ max}$	320		ns
$t_{HIGH}$	HIGH Period of the SCL Clock	Standard mode	4		$\mu s$
		Fast mode	600		ns
		High-speed mode, $C_B - 100 pF \text{ max}$	60		ns
		High-speed mode, $C_B - 400 pF \text{ max}$	120		ns
$t_{SU}, t_{STA}$	Setup Time for a Repeated START Condition	Standard mode	4.7		$\mu s$
		Fast mode	600		ns
		High-speed mode	160		ns
$t_{SU}, t_{DAT}$	Data Setup Time	Standard mode	250		ns
		Fast mode	100		ns
		High-speed mode	10		ns
$t_{HD}, t_{DAT}$	Data Hold Time	Standard mode	0	3.45	$\mu s$
		Fast mode	0	0.9	$\mu s$
		High-speed mode, $C_B - 100 pF \text{ max}$	0	70	ns
		High-speed mode, $C_B - 400 pF \text{ max}$	0	150	ns

(1) Specified by design. Not tested in production.

**I<sup>2</sup>C INTERFACE TIMING CHARACTERISTICS<sup>(1)</sup> (continued)**

PARAMETER		TEST CONDITIONS	MIN	MAX	UNIT
t <sub>RCL</sub>	Rise Time of SCL Signal	Standard mode	20 + 0.1 C <sub>B</sub>	1000	ns
		Fast mode	20 + 0.1 C <sub>B</sub>	300	ns
		High-speed mode, C <sub>B</sub> – 100 pF max	10	40	ns
		High-speed mode, C <sub>B</sub> – 400 pF max	20	80	ns
t <sub>RCL1</sub>	Rise Time of SCL Signal After a Repeated START Condition and After an Acknowledge BIT	Standard mode	20 + 0.1 C <sub>B</sub>	1000	ns
		Fast mode	20 + 0.1 C <sub>B</sub>	300	ns
		High-speed mode, C <sub>B</sub> – 100 pF max	10	80	ns
		High-speed mode, C <sub>B</sub> – 400 pF max	20	160	ns
t <sub>FCL</sub>	Fall Time of SCL Signal	Standard mode	20 + 0.1 C <sub>B</sub>	300	ns
		Fast mode	20 + 0.1 C <sub>B</sub>	300	ns
		High-speed mode, C <sub>B</sub> – 100 pF max	10	40	ns
		High-speed mode, C <sub>B</sub> – 400 pF max	20	80	ns
t <sub>RDA</sub>	Rise Time of SDA Signal	Standard mode	20 + 0.1 C <sub>B</sub>	1000	ns
		Fast mode	20 + 0.1 C <sub>B</sub>	300	ns
		High-speed mode, C <sub>B</sub> – 100 pF max	10	80	ns
		High-speed mode, C <sub>B</sub> – 400 pF max	20	160	ns
t <sub>FDA</sub>	Fall Time of SDA Signal	Standard mode	20 + 0.1 C <sub>B</sub>	300	ns
		Fast mode	20 + 0.1 C <sub>B</sub>	300	ns
		High-speed mode, C <sub>B</sub> – 100 pF max	10	80	ns
		High-speed mode, C <sub>B</sub> – 400 pF max	20	160	ns
t <sub>SU</sub> , t <sub>STO</sub>	Setup Time for STOP Condition	Standard mode	4		μs
		Fast mode	600		ns
		High-speed mode	160		ns
C <sub>B</sub>	Capacitive Load for SDA and SCL			400	pF

I<sup>2</sup>C TIMING DIAGRAMS

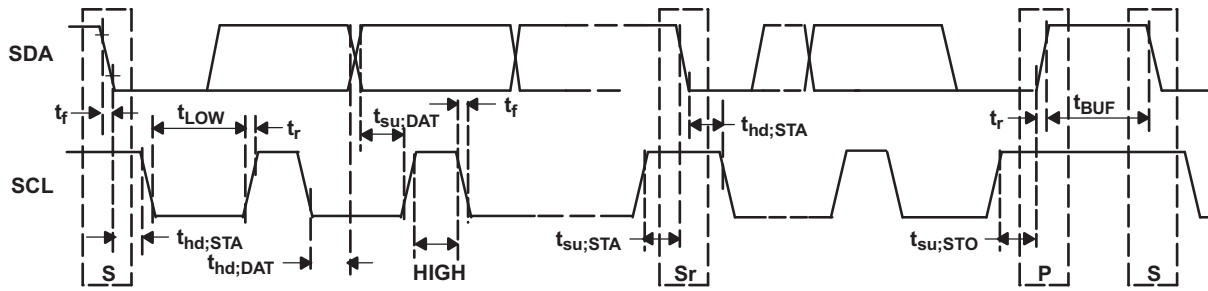
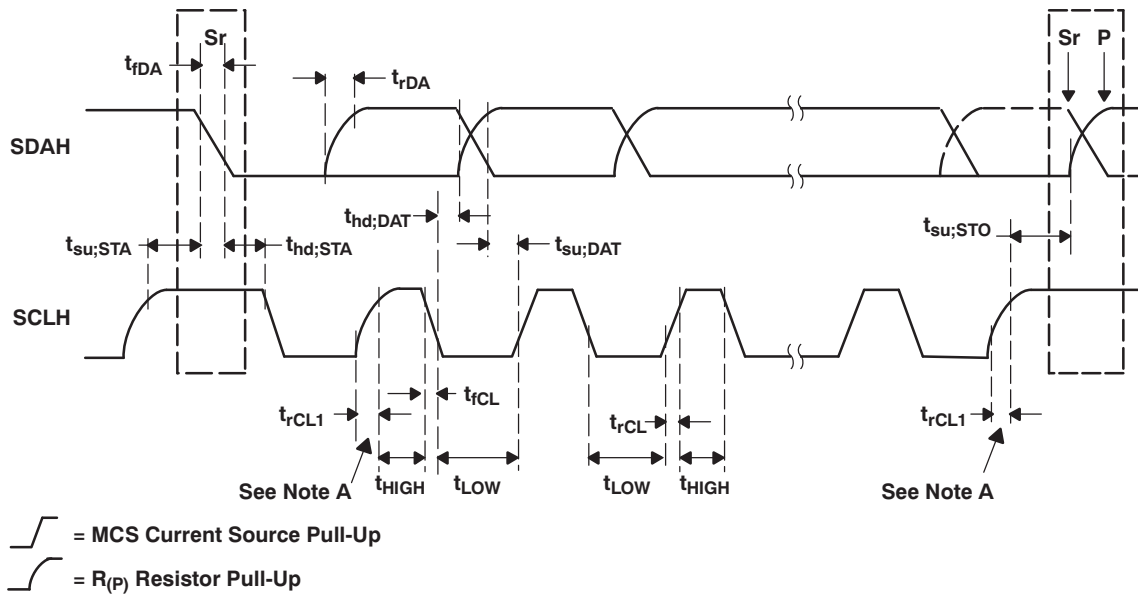

Figure 2. Serial Interface Timing for F/S-Mode



Note A: First rising edge of the SCLH signal after Sr and after each acknowledge bit.

Figure 3. Serial Interface Timing for H/S-Mode



DEVICE INFORMATION

APPLICATION DIAGRAMS

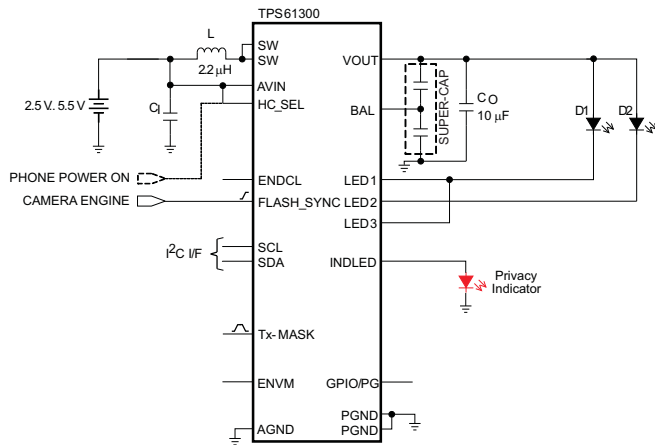

Figure 4. TPS61300, Typical Application

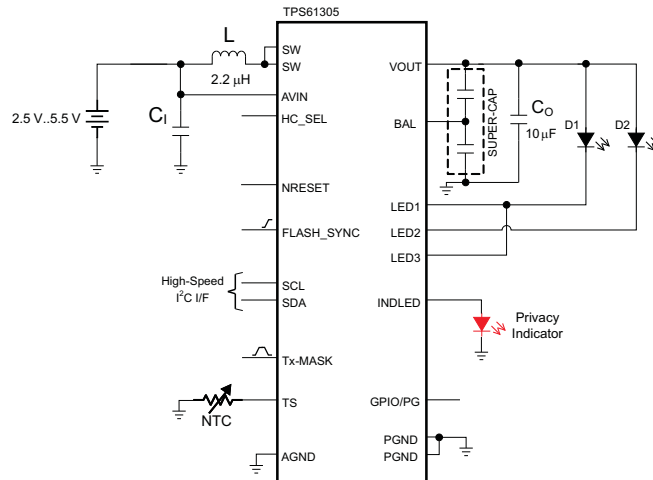

Figure 5. : TPS61305, Typical Application

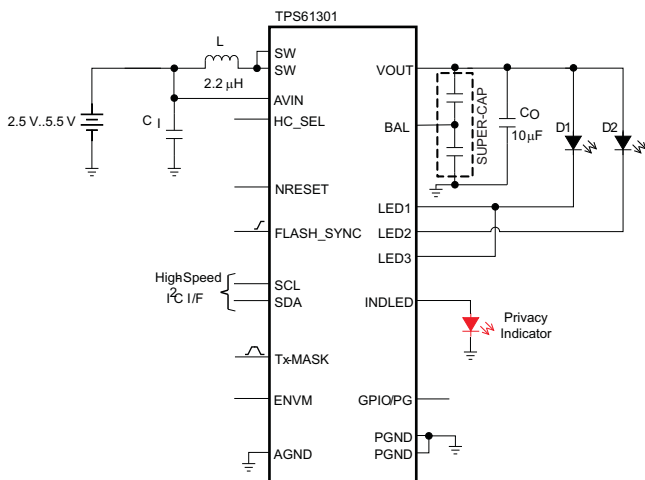

Figure 6. TPS61301, Typical Application

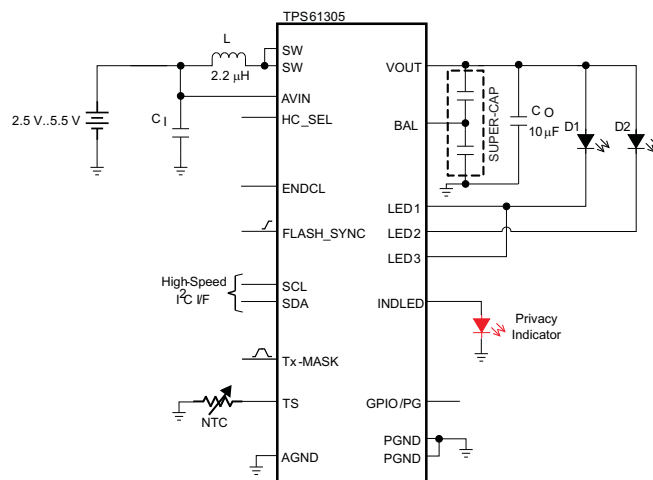
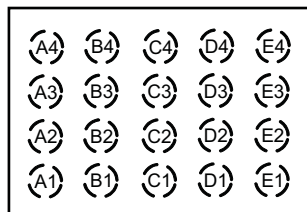

Figure 7. TPS61306, Typical Application

PIN ASSIGNMENTS

CSP-20  
(TOP VIEW)



CSP-20  
(BOTTOM VIEW)

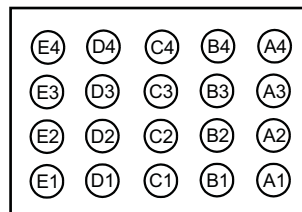

**PIN FUNCTIONS (TPS61300)**

PIN		I/O	DESCRIPTION
NAME	NO.		
AVIN	E4	I	This is the input voltage pin of the device. Connect directly to the input bypass capacitor.
VOUT	A2	O	This is the output voltage pin of the converter.
LED1	E2	I	LED return input. This feedback pin regulates the LED current through the internal sense resistor by regulating the voltage across it. The regulation operates with typically 400mV (HC_SEL = L) or 400mV (HC_SEL = H) dropout voltage. Connect to the cathode of the LEDs.
LED2	E1	I	
LED3	E3	I	
FLASH_SYNC	B4	I	Flashlight strobe pulse synchronization input. FLASH_SYNC = LOW: The device is operating and regulating the LED current to the DC light current level (DCLC). FLASH_SYNC = HIGH: The device is operating and regulating the LED current to the flashlight current level (FC).
HC_SEL	B3	I	Extended high-current mode selection input. This pin must not be left floating and must be terminated. <b>HC_SEL = LOW: LED direct drive mode.</b> The power stage is active and the maximum LED currents are defined as 400mA/800mA/400mA (ILED1/ILED2/ILED3). <b>HC_SEL = HIGH: Energy storage mode.</b> In flash mode, the power stage is either active with reduced current capability or disabled. The maximum LED current is defined as 925mA/1850mA/925mA (ILED1/ILED2/ILED3).
SCL	B2	I	Serial interface clock line. This pin must not be left floating and must be terminated.
SDA	B1	I/O	Serial interface address/data line. This pin must not be left floating and must be terminated.
GPIO/PG	D4	I/O	This pin can either be configured as a general purpose input/output pin (GPIO) or either as an open-drain or a push-pull output to signal when the converters output voltage is within the regulation limits (PG). Per default, the pin is configured as an open-drain power-good output.
ENVM	C4	I	Enable pin for voltage mode converter. Pulling this pin high forces the device into voltage regulation mode (V <sub>OUT</sub> is preset to a fixed value, 4.95V).
INDLED	A1	O	This pin provides a constant current source to drive low V <sub>F</sub> LEDs. Connect to LED anode.
ENDCL	D3	I	Hardware control pin for DC light operation. Pulling this pin high forces the device into DC light operation. The ENDCL input is only active when the device is programmed into shutdown or voltage mode regulation. LED1-3 inputs are controlled according to ENLED[3:1] bit settings.
Tx-MASK	C3	I	RF PA synchronization control input. Pulling this pin high turns the LED from flashlight to DC light operation, thereby reducing almost instantaneously the peak current loading from the battery.
SW	C1 C2	I/O	Inductor connection. Drain of the internal power MOSFET. Connect to the switched side of the inductor. SW is high impedance during shutdown.
BAL	A3	O	Balancing output for dual cells super-capacitor. In steady-state operation, this output compensates for leakage current mismatch between the cells.
PGND	D1 D2		Power ground. Connect to AGND underneath IC.
AGND	A4		Analog ground.

**PIN FUNCTIONS (TPS61301)**

PIN		I/O	DESCRIPTION
NAME	NO.		
AVIN	E4	I	This is the input voltage pin of the device. Connect directly to the input bypass capacitor.
VOUT	A2	O	This is the output voltage pin of the converter.
LED1	E2	I	LED return input. This feedback pin regulates the LED current through the internal sense resistor by regulating the voltage across it. The regulation operates with typically 400mV (HC_SEL = L) or 400mV (HC_SEL = H) dropout voltage. Connect to the cathode of the LEDs.
LED2	E1	I	
LED3	E3	I	
FLASH_SYNC	B4	I	Flashlight strobe pulse synchronization input. FLASH_SYNC = LOW: The device is operating and regulating the LED current to the DC light current level (DCLC). FLASH_SYNC = HIGH: The device is operating and regulating the LED current to the flashlight current level (FC).
HC_SEL	B3	I	Extended high-current mode selection input. This pin must not be left floating and must be terminated. <b>HC_SEL = LOW: LED direct drive mode.</b> The power stage is active and the maximum LED currents are defined as 400mA/800mA/400mA (ILED1/ILED2/ILED3). <b>HC_SEL = HIGH: Energy storage mode.</b> In flash mode, the power stage is either active with reduced current capability or disabled. The maximum LED current is defined as 925mA/1850mA/925mA (ILED1/ILED2/ILED3).
SCL	B2	I	Serial interface clock line. This pin must not be left floating and must be terminated.
SDA	B1	I/O	Serial interface address/data line. This pin must not be left floating and must be terminated.
GPIO/PG	D4	I/O	This pin can either be configured as a general purpose input/output pin (GPIO) or either as an open-drain or a push-pull output to signal when the converters output voltage is within the regulation limits (PG). Per default, the pin is configured as an open-drain power-good output.
ENVM	C4	I	Enable pin for voltage mode converter. Pulling this pin high forces the device into voltage regulation mode (V <sub>OUT</sub> is preset to a fixed value, 4.95V).
INDLED	A1	O	This pin provides a constant current source to drive low V <sub>F</sub> LEDs. Connect to LED anode.
NRESET	D3	I	Master hardware reset input. NRESET = LOW: The device is forced in shutdown mode and the I <sup>2</sup> C control I/F is reset. NRESET = HIGH: The device is operating normally under the control of the I <sup>2</sup> C interface.
Tx-MASK	C3	I	RF PA synchronization control input. Pulling this pin high turns the LED from flashlight to DC light operation, thereby reducing almost instantaneously the peak current loading from the battery.
SW	C1 C2	I/O	Inductor connection. Drain of the internal power MOSFET. Connect to the switched side of the inductor. SW is high impedance during shutdown.
BAL	A3	O	Balancing output for dual cells super-capacitor. In steady-state operation, this output compensates for leakage current mismatch between the cells.
PGND	D1 D2		Power ground. Connect to AGND underneath IC.
AGND	A4		Analog ground.

**PIN FUNCTIONS (TPS61305)**

PIN		I/O	DESCRIPTION
NAME	NO.		
AVIN	E4	I	This is the input voltage pin of the device. Connect directly to the input bypass capacitor.
VOUT	A2	O	This is the output voltage pin of the converter.
LED1	E2	I	LED return input. This feedback pin regulates the LED current through the internal sense resistor by regulating the voltage across it. The regulation operates with typically 400mV (HC_SEL = L) or 400mV (HC_SEL = H) dropout voltage. Connect to the cathode of the LEDs.
LED2	E1	I	
LED3	E3	I	
FLASH_SYNC	B4	I	Flashlight strobe pulse synchronization input. FLASH_SYNC = LOW: The device is operating and regulating the LED current to the DC light current level (DCLC). FLASH_SYNC = HIGH: The device is operating and regulating the LED current to the flashlight current level (FC).
HC_SEL	B3	I	Extended high-current mode selection input. This pin must not be left floating and must be terminated. <b>HC_SEL = LOW: LED direct drive mode.</b> The power stage is active and the maximum LED currents are defined as 445mA/890mA/445mA (ILED1/ILED2/ILED3). <b>HC_SEL = HIGH: Energy storage mode.</b> In flash mode, the power stage is either active with reduced current capability or disabled. The maximum LED current is defined as 1025mA/2050mA/1025mA (ILED1/ILED2/ILED3).
SCL	B2	I	Serial interface clock line. This pin must not be left floating and must be terminated.
SDA	B1	I/O	Serial interface address/data line. This pin must not be left floating and must be terminated.
GPIO/PG	D4	I/O	This pin can either be configured as a general purpose input/output pin (GPIO) or either as an open-drain or a push-pull output to signal when the converters output voltage is within the regulation limits (PG). Per default, the pin is configured as an open-drain power-good output.
TS	C4	I/O	NTC resistor connection. This pin can be used to monitor the LED temperature. Connect a 220kΩ NTC resistor from the TS input to ground. In case this functionality is not desired, the TS input should be tied to AVIN or left floating.
INDLED	A1	O	This pin provides a constant current source to drive low $V_F$ LEDs. Connect to LED anode.
NRESET	D3	I	Master hardware reset input. NRESET = LOW: The device is forced in shutdown mode and the I <sup>2</sup> C control I/F is reset. NRESET = HIGH: The device is operating normally under the control of the I <sup>2</sup> C interface.
Tx-MASK	C3	I	RF PA synchronization control input. Pulling this pin high turns the LED from flashlight to DC light operation, thereby reducing almost instantaneously the peak current loading from the battery.
SW	C1 C2	I/O	Inductor connection. Drain of the internal power MOSFET. Connect to the switched side of the inductor. SW is high impedance during shutdown.
BAL	A3	O	Balancing output for dual cells super-capacitor. In steady-state operation, this output compensates for leakage current mismatch between the cells.
PGND	D1 D2		Power ground. Connect to AGND underneath IC.
AGND	A4		Analog ground.

**PIN FUNCTIONS (TPS61306)**

PIN		I/O	DESCRIPTION
NAME	NO.		
AVIN	E4	I	This is the input voltage pin of the device. Connect directly to the input bypass capacitor.
VOUT	A2	O	This is the output voltage pin of the converter.
LED1	E2	I	LED return input. This feedback pin regulates the LED current through the internal sense resistor by regulating the voltage across it. The regulation operates with typically 400mV (HC_SEL = L) or 400mV (HC_SEL = H) dropout voltage. Connect to the cathode of the LEDs.
LED2	E1	I	
LED3	E3	I	
FLASH_SYNC	B4	I	Flashlight strobe pulse synchronization input. FLASH_SYNC = LOW: The device is operating and regulating the LED current to the DC light current level (DCLC). FLASH_SYNC = HIGH: The device is operating and regulating the LED current to the flashlight current level (FC).
HC_SEL	B3	I	Extended high-current mode selection input. This pin must not be left floating and must be terminated. <b>HC_SEL = LOW: LED direct drive mode.</b> The power stage is active and the maximum LED currents are defined as 445mA/890mA/445mA (ILED1/ILED2/ILED3). <b>HC_SEL = HIGH: Energy storage mode.</b> In flash mode, the power stage is either active with reduced current capability or disabled. The maximum LED current is defined as 1025mA/2050mA/1025mA (ILED1/ILED2/ILED3).
SCL	B2	I	Serial interface clock line. This pin must not be left floating and must be terminated.
SDA	B1	I/O	Serial interface address/data line. This pin must not be left floating and must be terminated.
GPIO/PG	D4	I/O	This pin can either be configured as a general purpose input/output pin (GPIO) or either as an open-drain or a push-pull output to signal when the converters output voltage is within the regulation limits (PG). Per default, the pin is configured as an open-drain power-good output.
TS	C4	I/O	NTC resistor connection. This pin can be used to monitor the LED temperature. Connect a 220kΩ NTC resistor from the TS input to ground. In case this functionality is not desired, the TS input should be tied to AVIN or left floating.
INDLED	A1	O	This pin provides a constant current source to drive low $V_F$ LEDs. Connect to LED anode.
ENDCL	D3	I	Hardware control pin for DC light operation. Pulling this pin high forces the device into DC light operation. The ENDCL input is only active when the device is programmed into shutdown or voltage mode regulation. LED1-3 inputs are controlled according to ENLED[3:1] bit settings.
Tx-MASK	C3	I	RF PA synchronization control input. Pulling this pin high turns the LED from flashlight to DC light operation, thereby reducing almost instantaneously the peak current loading from the battery.
SW	C1 C2	I/O	Inductor connection. Drain of the internal power MOSFET. Connect to the switched side of the inductor. SW is high impedance during shutdown.
BAL	A3	O	Balancing output for dual cells super-capacitor. In steady-state operation, this output compensates for leakage current mismatch between the cells.
PGND	D1 D2		Power ground. Connect to AGND underneath IC.
AGND	A4		Analog ground.

**FUNCTIONAL BLOCK DIAGRAM (TPS61300)**

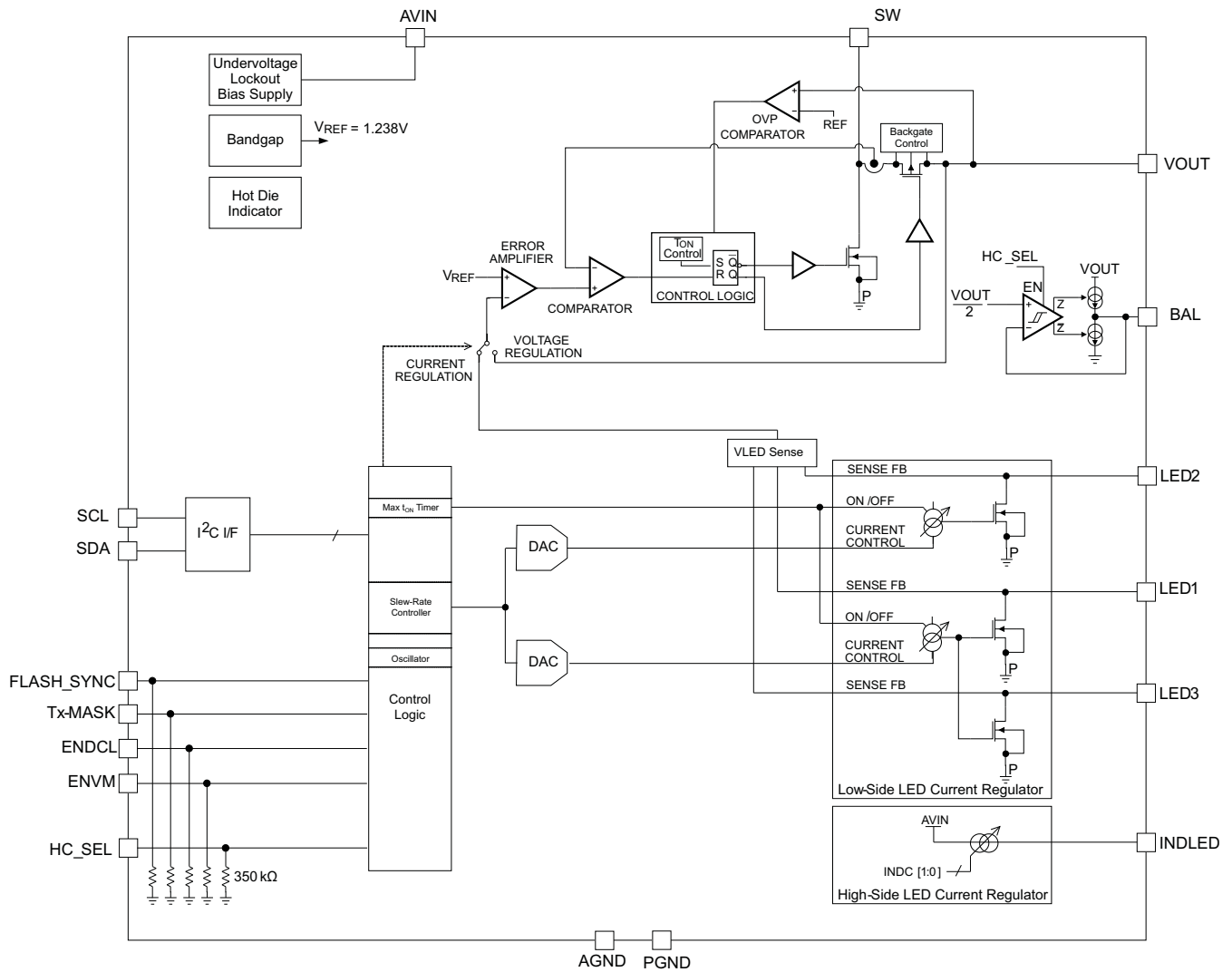

FUNCTIONAL BLOCK DIAGRAM (TPS61301)

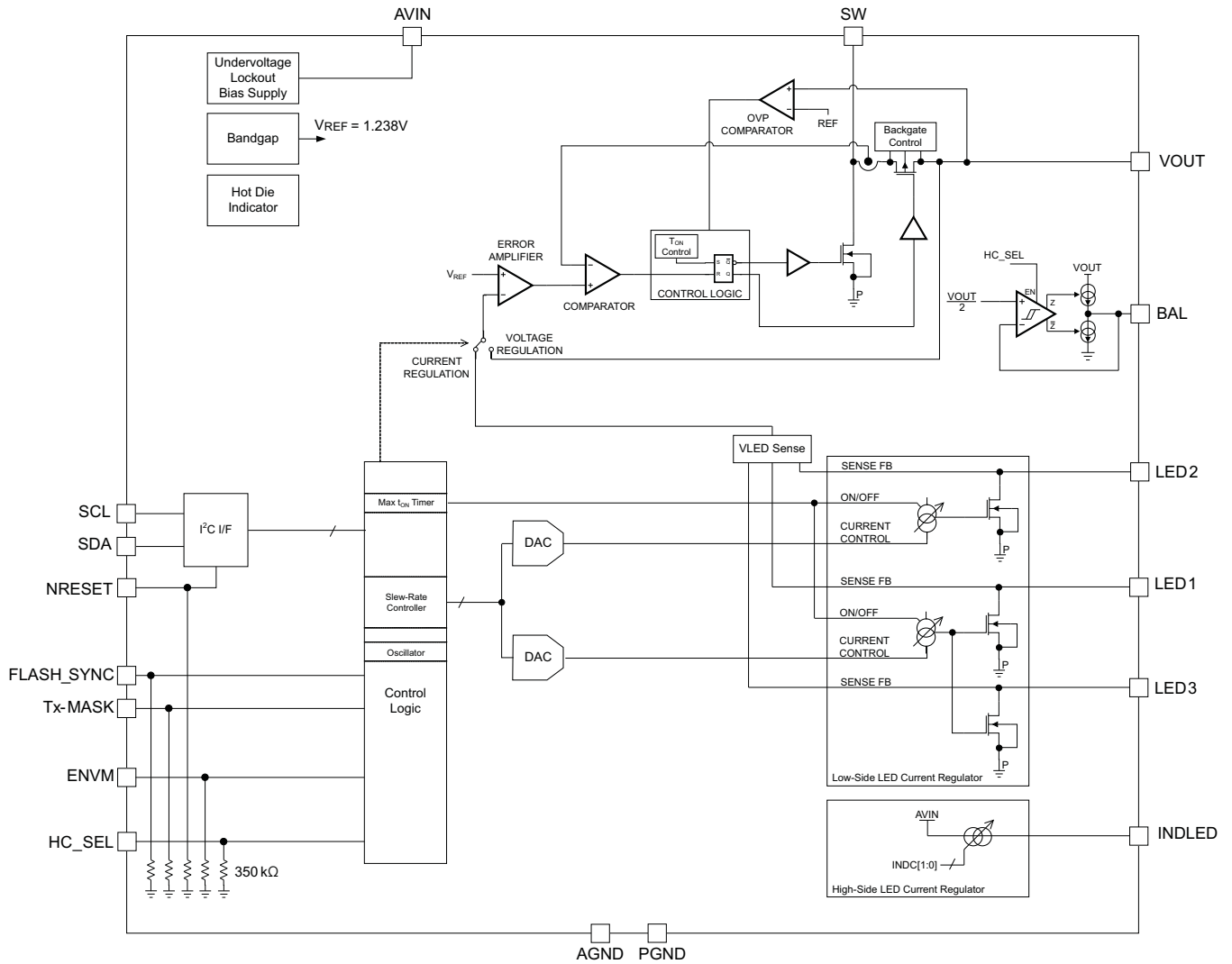

**FUNCTIONAL BLOCK DIAGRAM (TPS61305)**

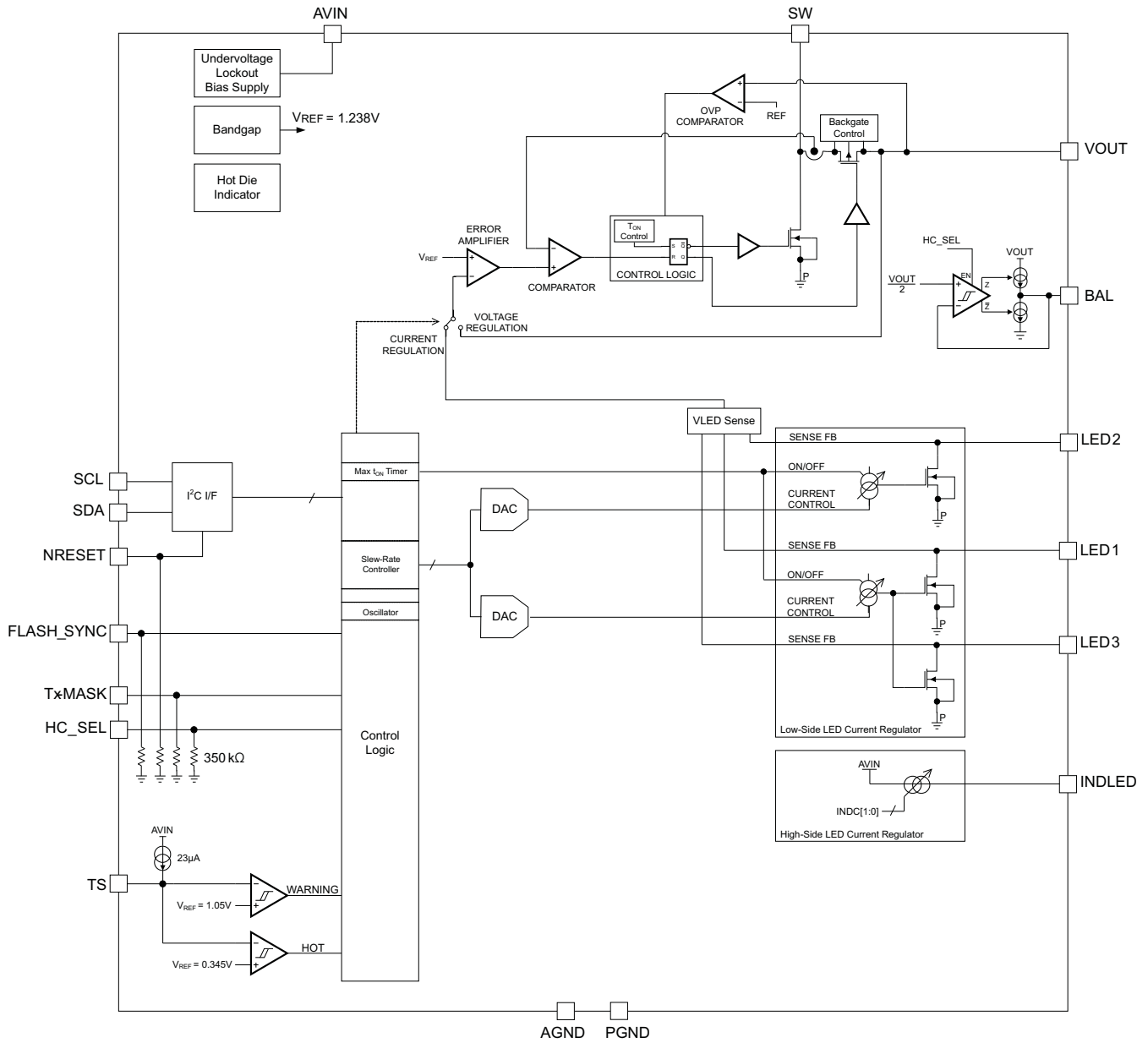



FUNCTIONAL BLOCK DIAGRAM (TPS61306)

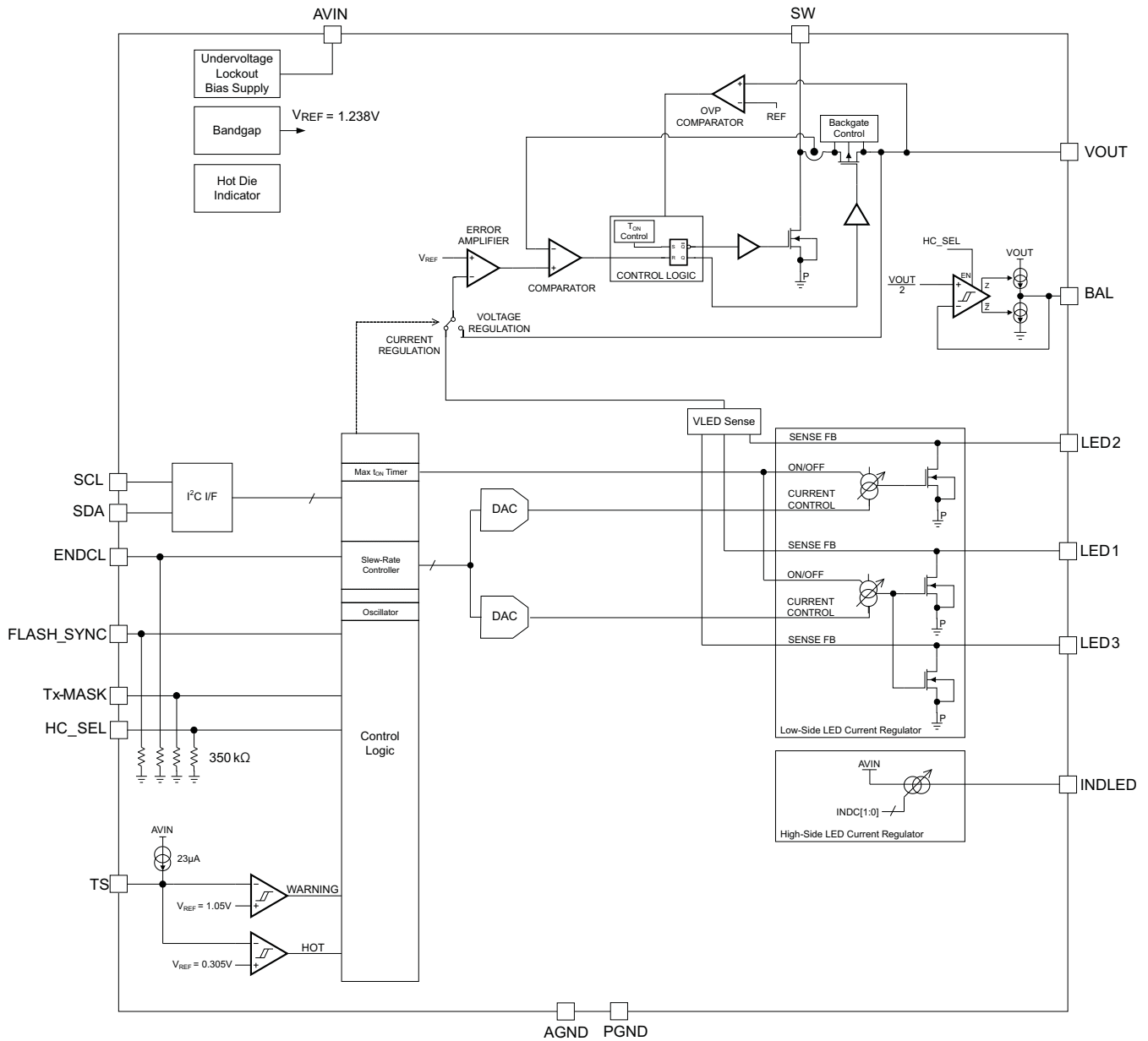

### TIMER BLOCK DIAGRAM

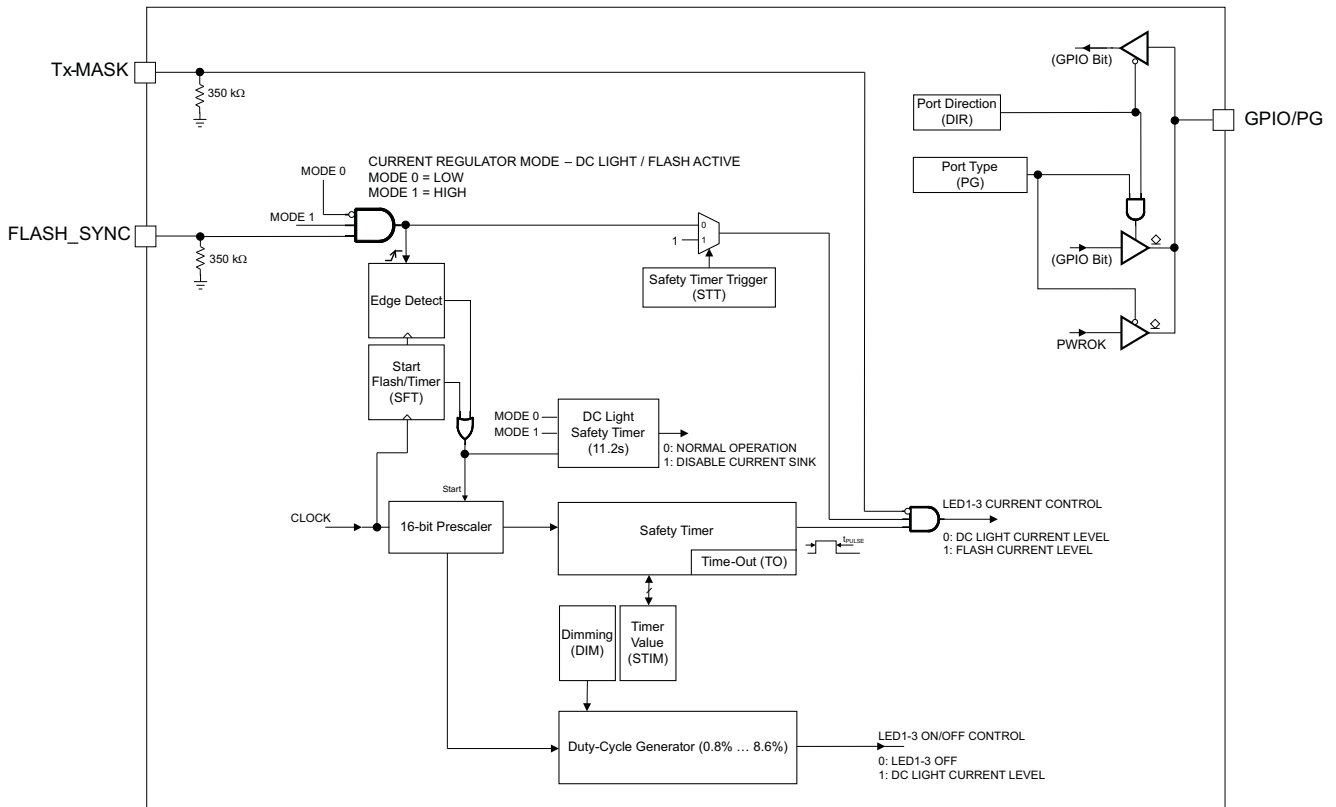

PARAMETER MEASUREMENT INFORMATION

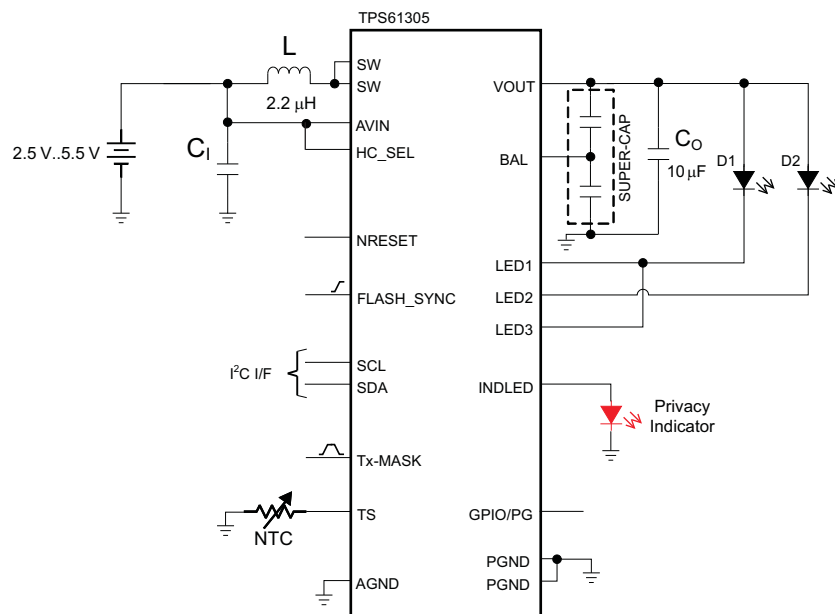
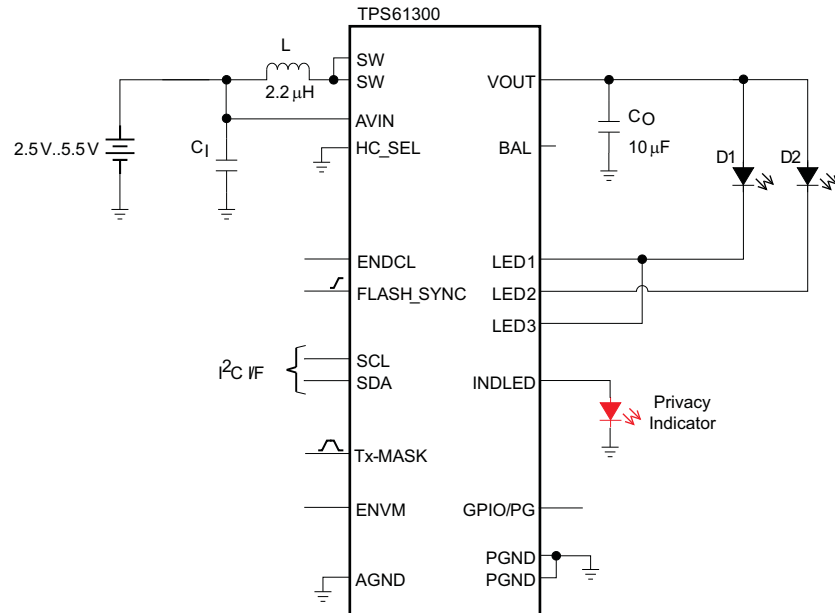

List of Components:

- L = 2.2µH, Wuerth Elektronik WE-TPC Series
- C<sub>1</sub>, C<sub>O</sub> = 10µF 6.3V X5R 0603 – TDK C1605X5R0J106MT
- Storage Capacitor = TDK EDLC262020-500mF
- NTC = 220kΩ, muRata NCP18WM224J03RB

## TYPICAL CHARACTERISTICS

### Table of Graphs

		<b>FIGURE</b>
LED Power Efficiency	vs. Input Voltage	Figure 8, Figure 9
DC Input Current	vs. Input Voltage	Figure 10
LED Current	vs. LED Pin Headroom Voltage	Figure 11, Figure 12, Figure 13
LED Current	vs. LED Current Digital Code	Figure 14, Figure 15, Figure 16, Figure 17
INDLED Current	vs. LED Pin Headroom Voltage	Figure 18
Voltage Mode Efficiency	vs. Output Current	Figure 19, Figure 20
DC Output Voltage	vs. Output Current	Figure 21, Figure 22
Maximum Output Current	vs. Input Voltage	Figure 23
DC Pre-Charge Current	vs. Differential Input-Output Voltage	Figure 24, Figure 25
Valley Current Limit		Figure 26, Figure 27
Balancing Current	vs. Balance Pin Voltage	Figure 28
Supply Current	vs. Input Voltage	Figure 29
Standby Current	vs. Ambient Temperature	Figure 30
Temperature Detection Threshold		Figure 31, Figure 32
Junction Temperature	vs. Port Voltage	Figure 33
Flash Sequence (Direct Drive Mode)		Figure 34
Tx-Masking Operation		Figure 35, Figure 36, Figure 37
Low-Light Dimming Mode Operation		Figure 38
PWM Operation		Figure 39
PFM Operation		Figure 40
Down-Mode Operation (Voltage Mode)		Figure 41
Voltage Mode Load Transient Response		Figure 42
Start-up Into DC Light Operation		Figure 43
Start-up Into Voltage Mode Operation		Figure 44
Storage Capacitor Pre-Charge		Figure 45
Storage Capacitor Charge-Up		Figure 46, Figure 47, Figure 48
DC Light Operation (Energy Storage Mode)		Figure 49
Flash Sequence (Energy Storage Mode)		Figure 50, Figure 51, Figure 52, Figure 53, Figure 54
Junction Temperature Monitoring		Figure 55
Shutdown (Energy Storage Mode)		Figure 56

TYPICAL CHARACTERISTICS (continued)

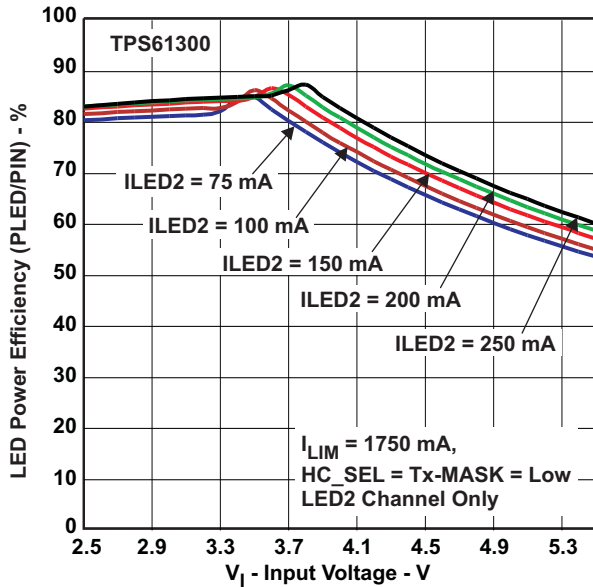

Figure 8. LED Power Efficiency vs. Input Voltage

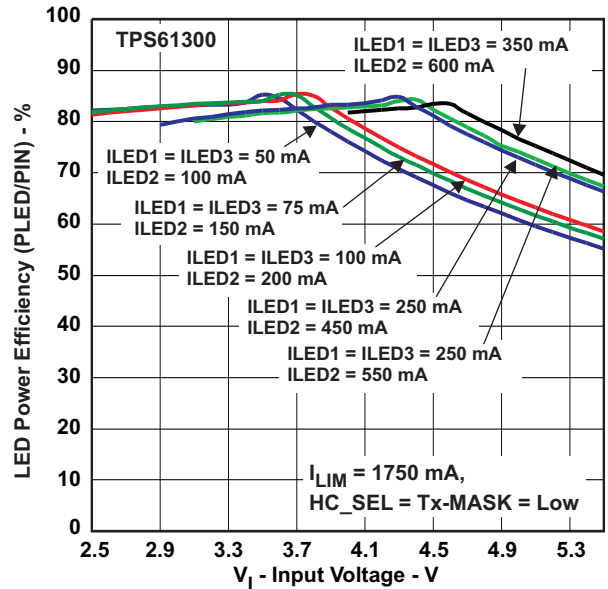

Figure 9. LED Power Efficiency vs. Input Voltage

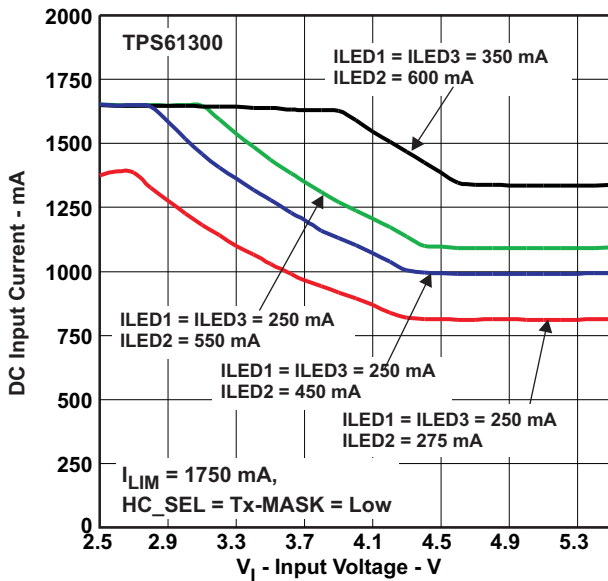

Figure 10. DC Input Current vs. Input Voltage

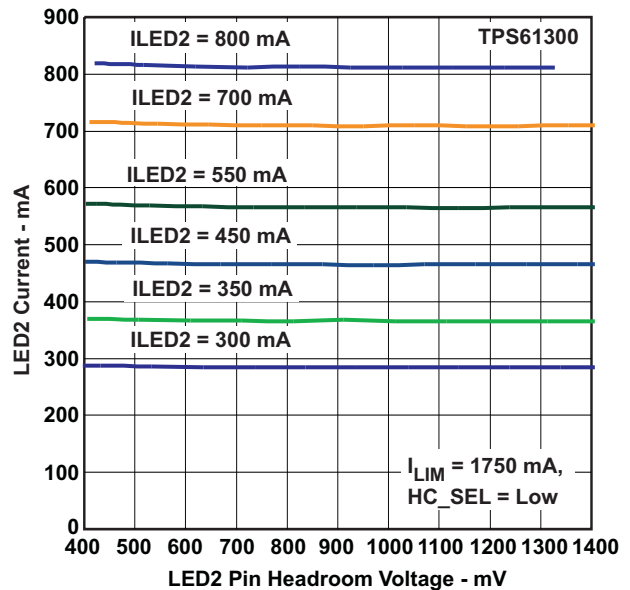

Figure 11. LED2 Current vs. LED2 Pin Headroom Voltage (HC\_SEL=0)

TYPICAL CHARACTERISTICS (continued)

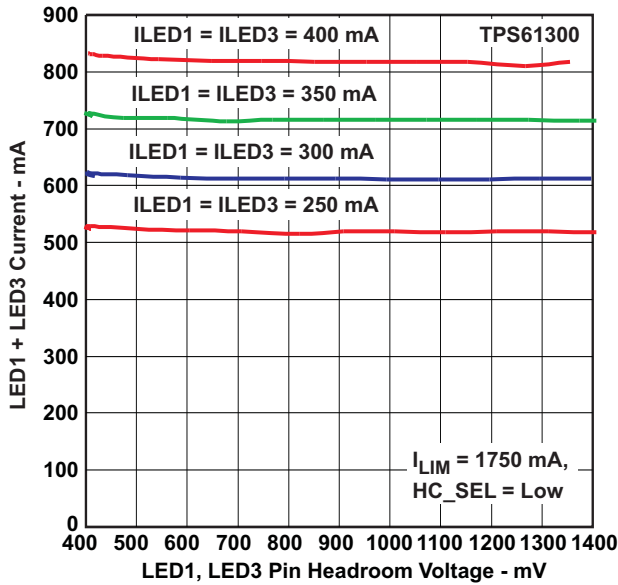

Figure 12. LED1+LED3 Current vs. LED1+LED3 Pin Headroom Voltage (HC\_SEL=0)

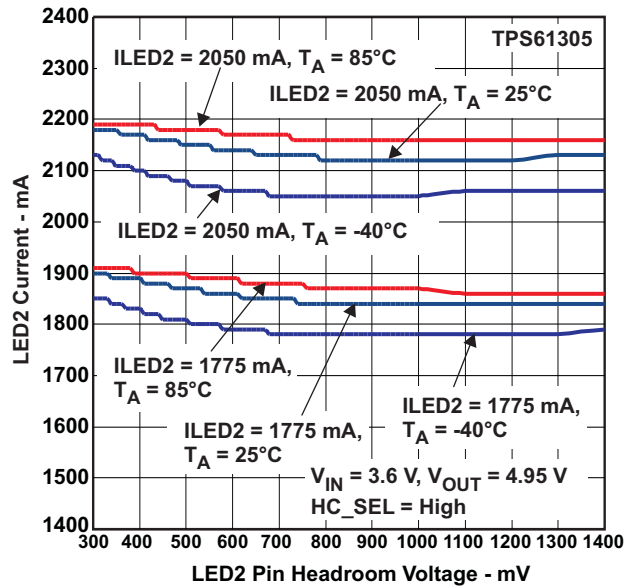

Figure 13. LED2 Current vs. LED2 Pin Headroom Voltage (HC\_SEL=1)

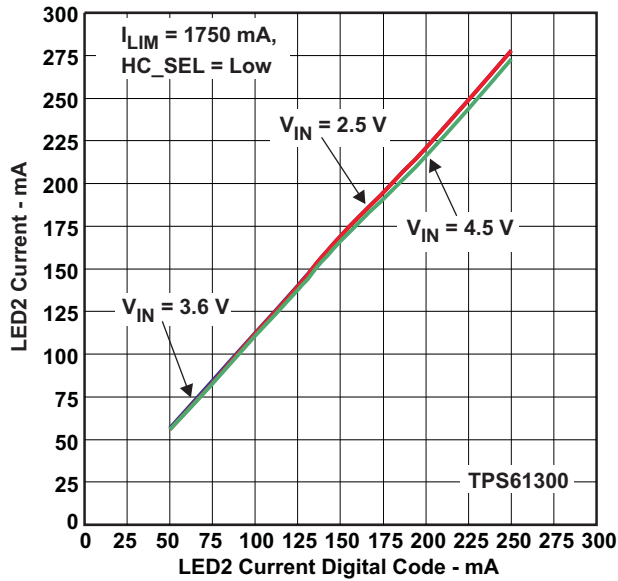

Figure 14. LED2 Current vs. LED2 Current Digital Code (HC\_SEL=0)

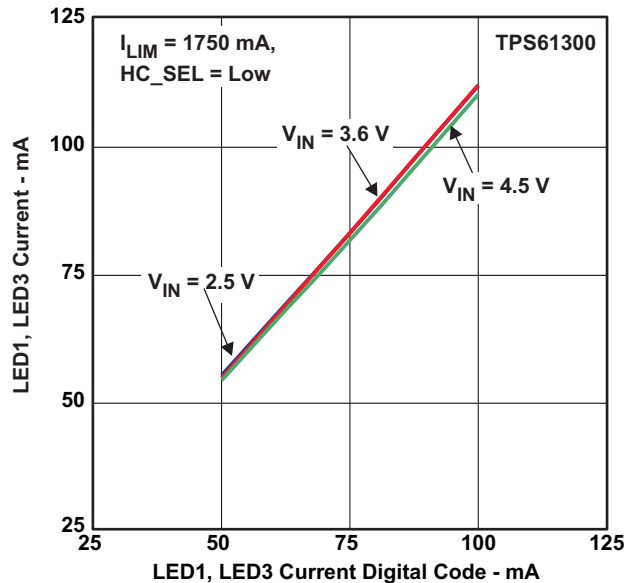

Figure 15. LED1, LED3 Current vs. LED1, LED3 Current Digital Code (HC\_SEL=0)

TYPICAL CHARACTERISTICS (continued)

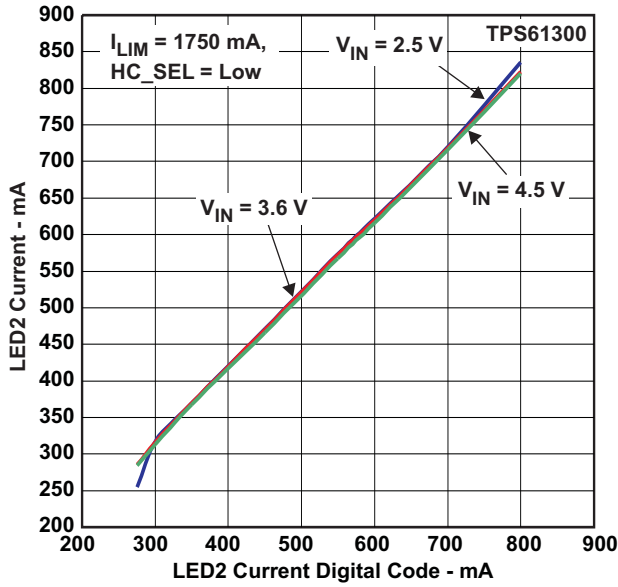

Figure 16. LED2 Current vs. LED2 Current Digital Code (HC\_SEL=0)

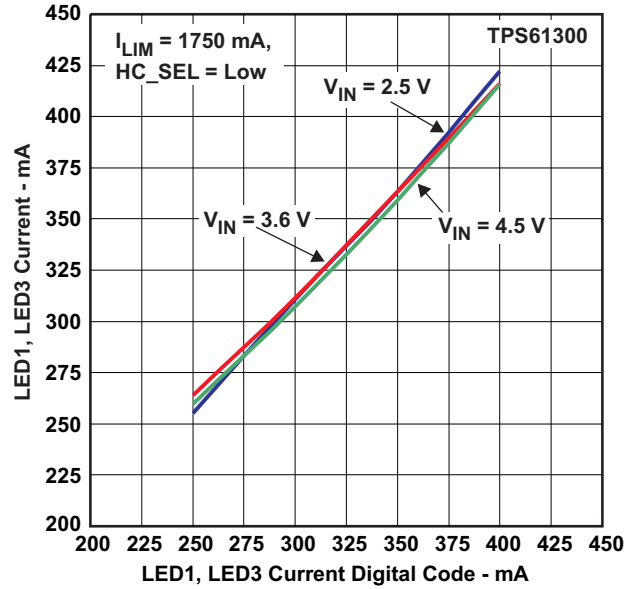

Figure 17. LED1, LED3 Current vs. LED1, LED3 Current Digital Code (HC\_SEL=0)

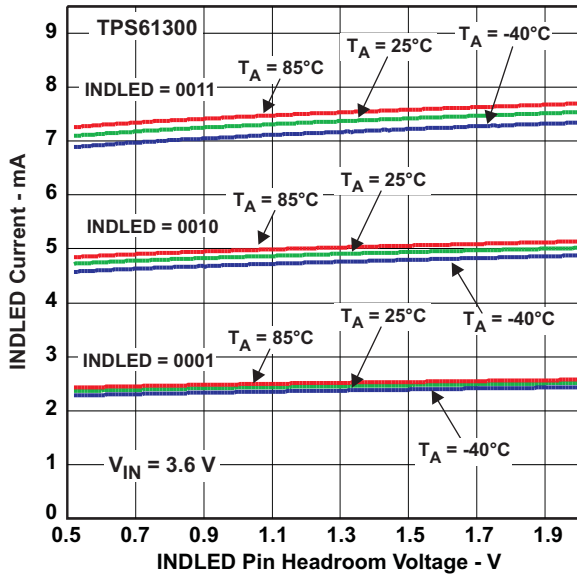

Figure 18. INDLED Current vs. INDLED Pin Headroom Voltage

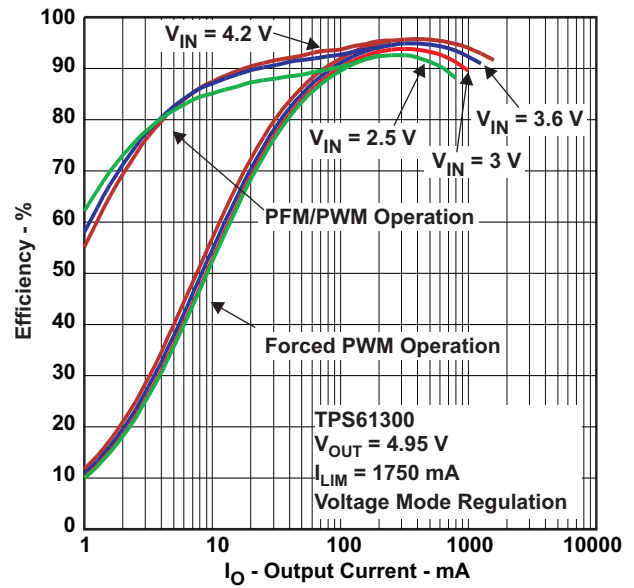

Figure 19. Efficiency vs. Output Current

TYPICAL CHARACTERISTICS (continued)

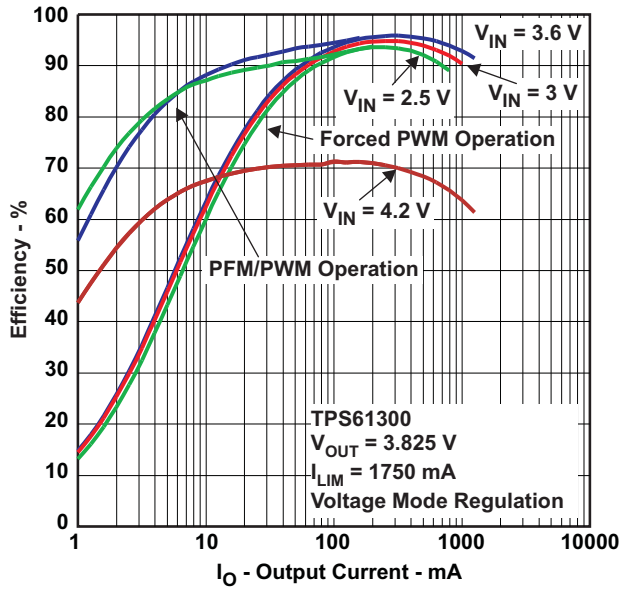

Figure 20. Efficiency vs. Output Current

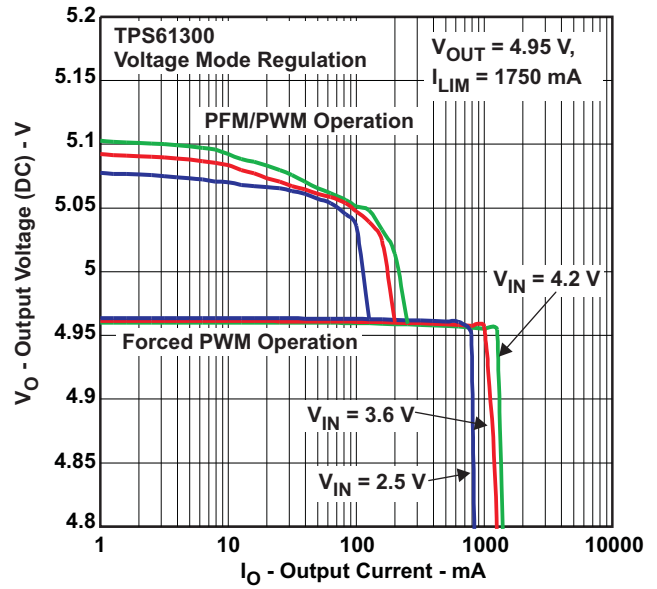

Figure 21. DC Output Voltage vs. Load Current

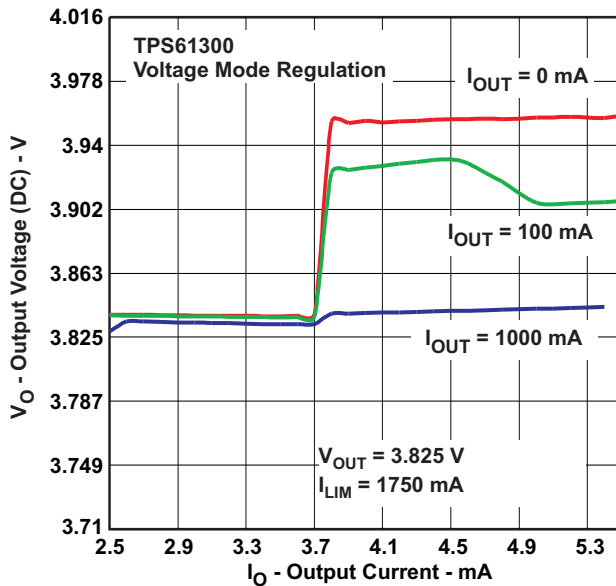

Figure 22. DC Output Voltage vs. Load Current

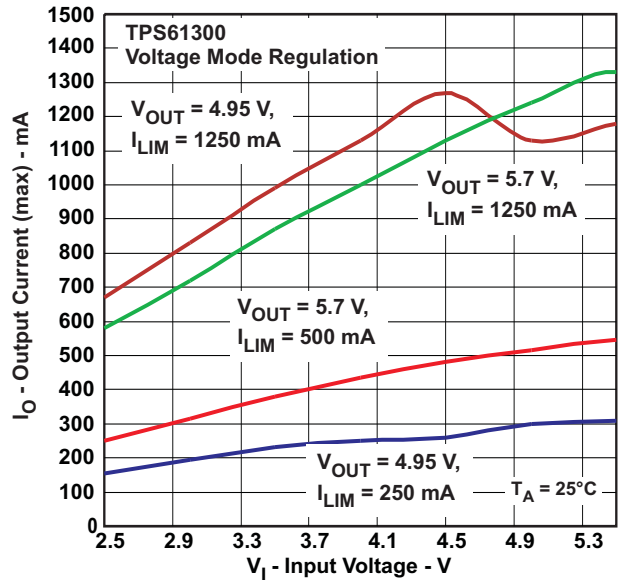

Figure 23. Maximum Output Current vs. Input Voltage



TYPICAL CHARACTERISTICS (continued)

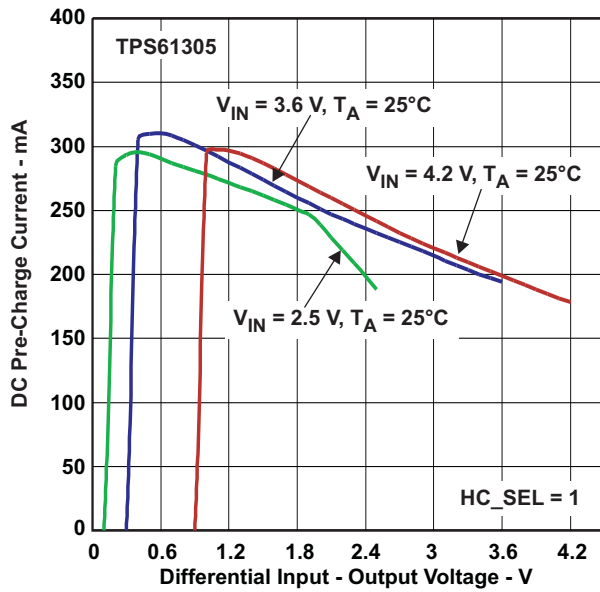

Figure 24. DC Pre-Charge Current vs. Differential Input-Output Voltage (HC\_SEL=1)

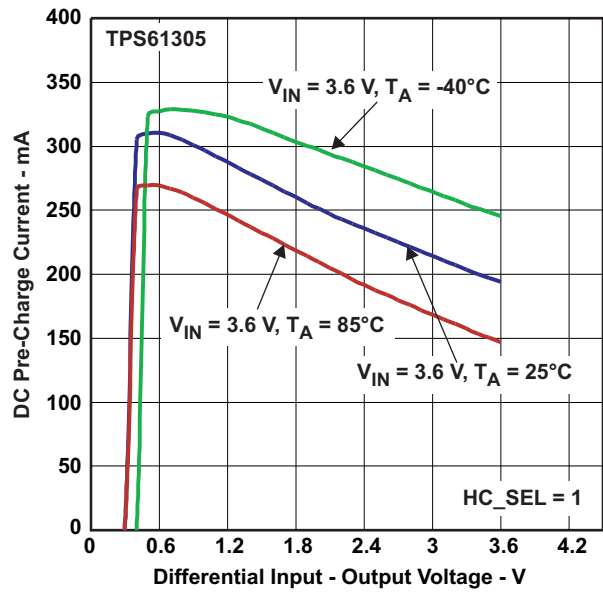

Figure 25. DC Pre-Charge Current vs. Differential Input-Output Voltage (HC\_SEL=1)

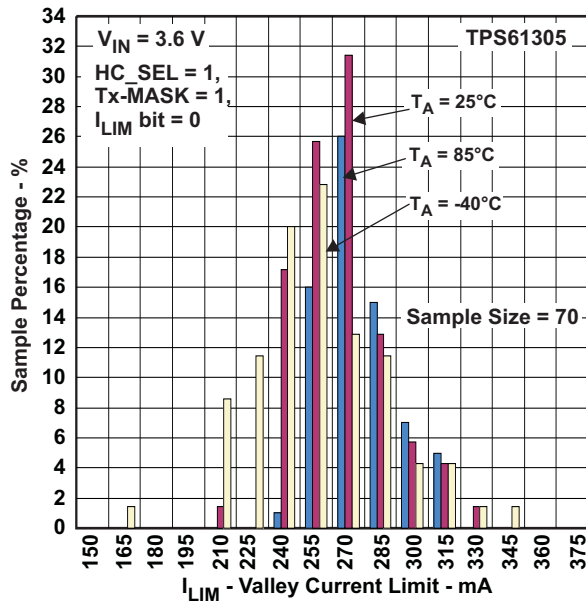

Figure 26. Valley Current Limit (HC\_SEL=1)

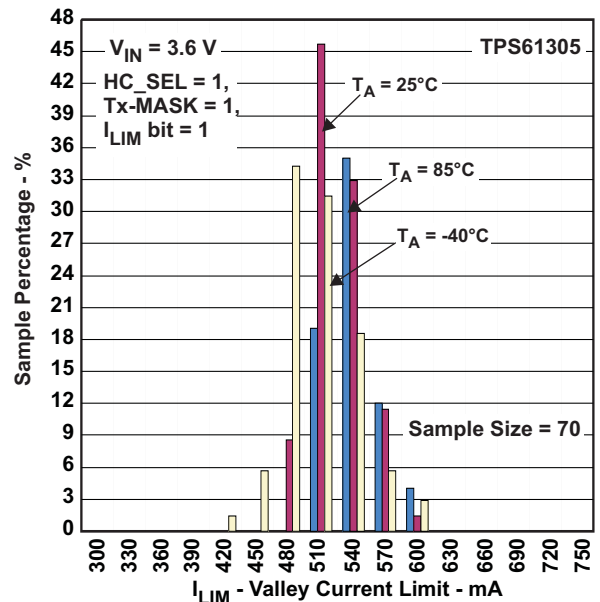

Figure 27. Valley Current Limit (HC\_SEL=1)

TYPICAL CHARACTERISTICS (continued)

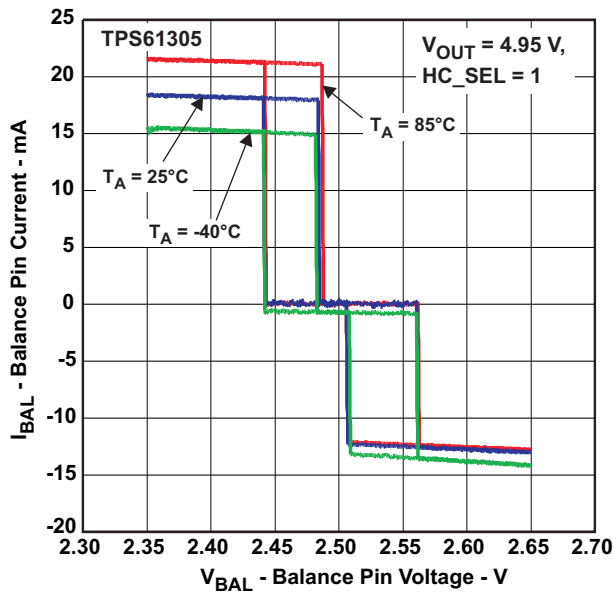

Figure 28. Balancing Current vs. Balance Pin Voltage

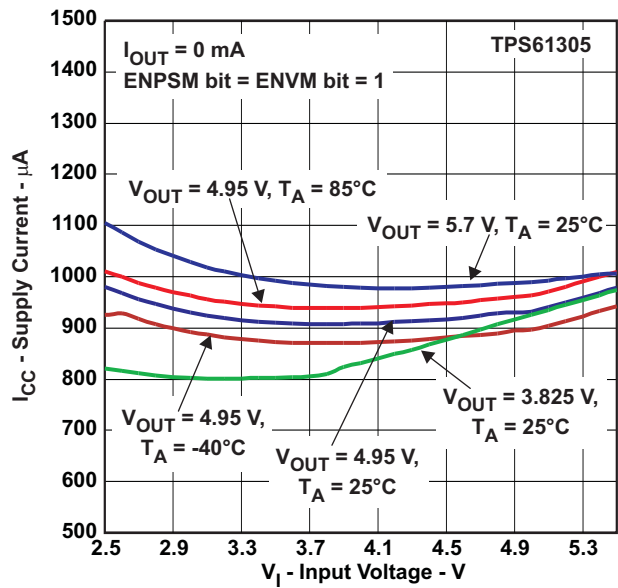

Figure 29. Supply Current vs. Input Voltage

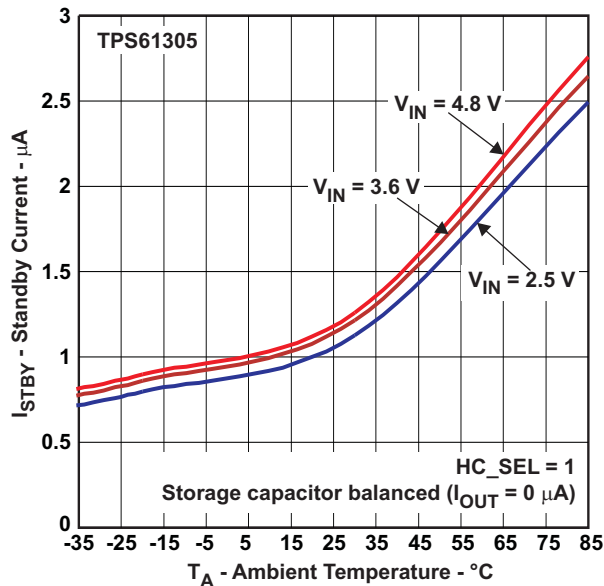

Figure 30. Standby Current vs. Ambient Temperature (HC\_SEL=1)

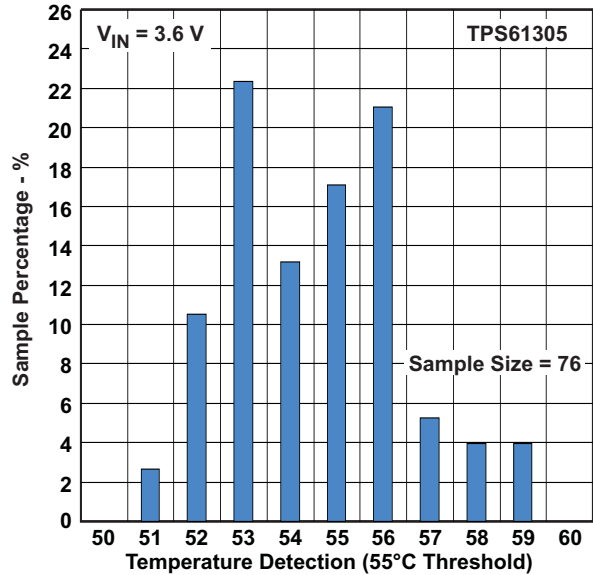

Figure 31. Temperature Detection Threshold

TYPICAL CHARACTERISTICS (continued)

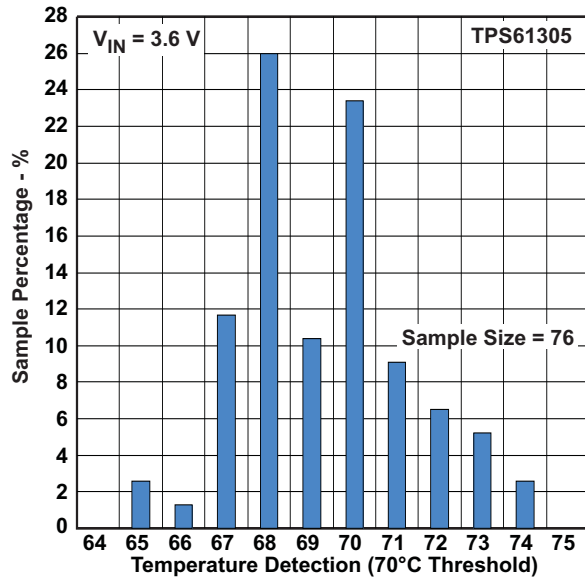

Figure 32. Temperature Detection Threshold

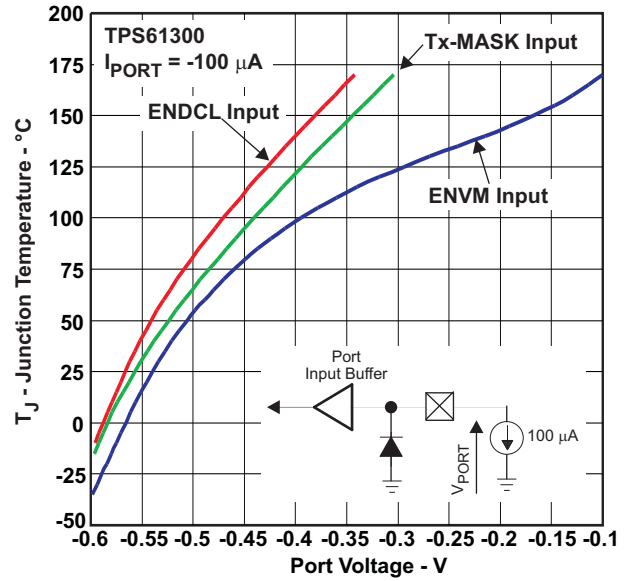

Figure 33. Junction Temperature vs. Port Voltage

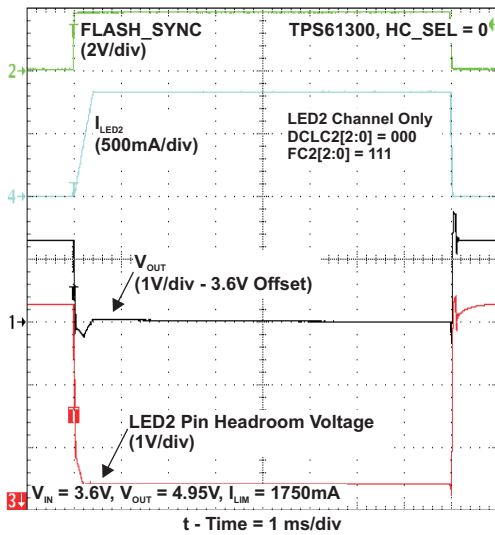

Figure 34. FLASH SEQUENCE (HC\_SEL=0)

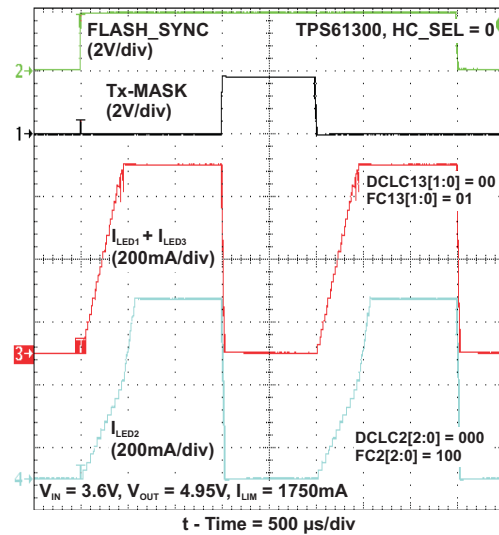

Figure 35. Tx-MASKING OPERATION (HC\_SEL=0)

TYPICAL CHARACTERISTICS (continued)

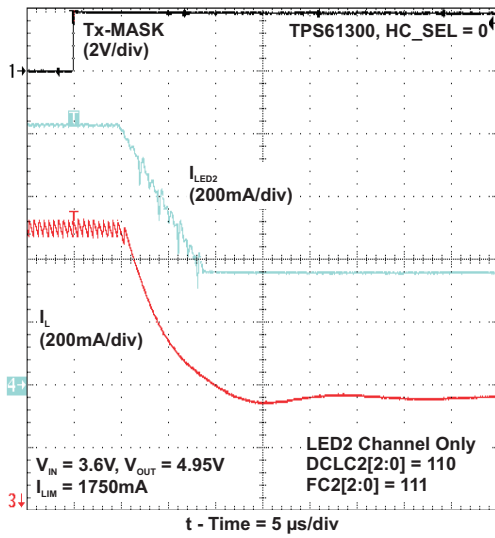

Figure 36. Tx-MASKING OPERATION (HC\_SEL=0)

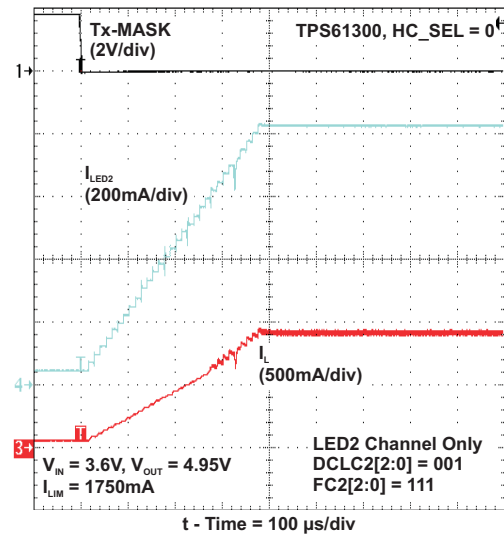

Figure 37. Tx-MASKING OPERATION (HC\_SEL=0)

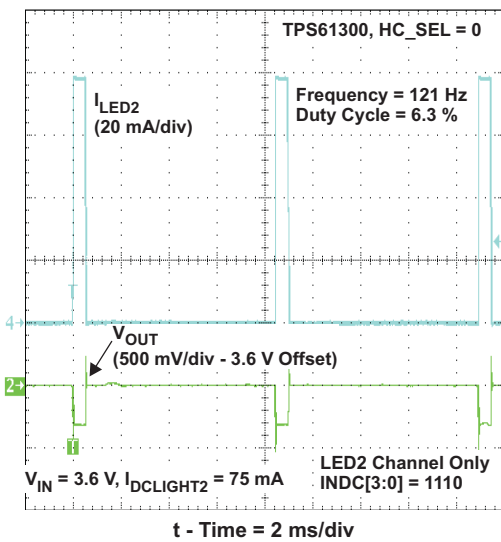

Figure 38. LOW-LIGHT DIMMING MODE OPERATION

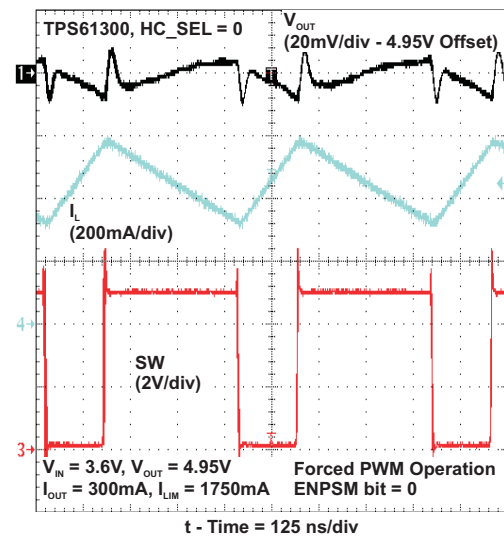

Figure 39. PWM OPERATION

TYPICAL CHARACTERISTICS (continued)

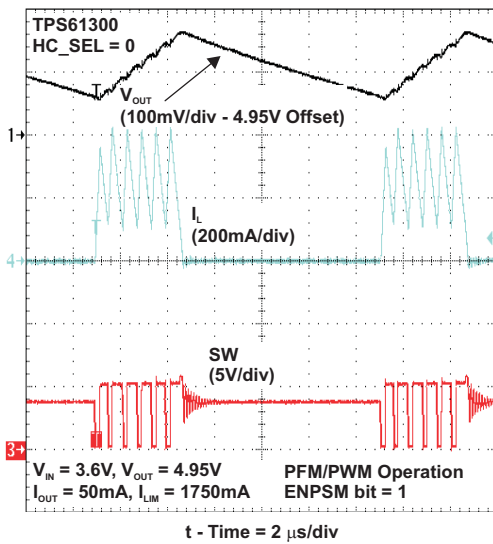

Figure 40. PFM OPERATION

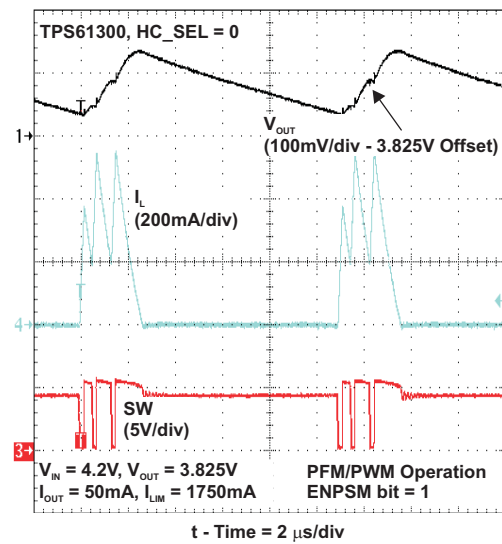

Figure 41. DOWN-MODE OPERATION (VOLTAGE MODE)

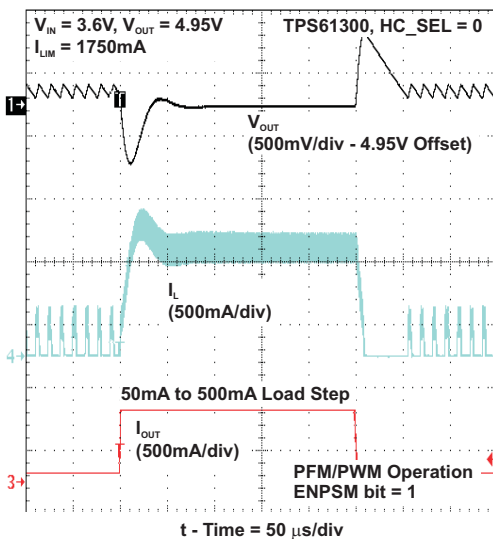

Figure 42. VOLTAGE MODE LOAD TRANSIENT RESPONSE

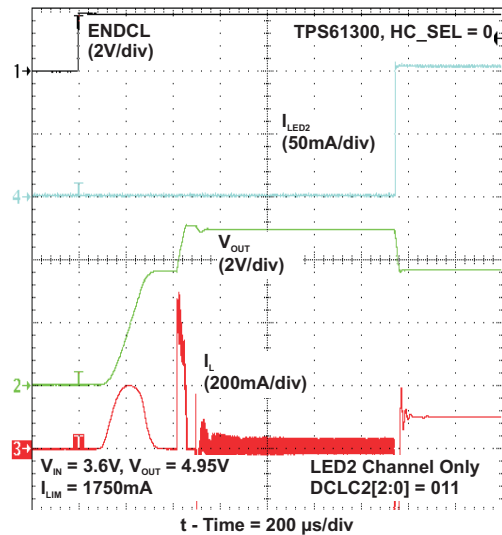

Figure 43. START-UP INTO DC LIGHT OPERATION

TYPICAL CHARACTERISTICS (continued)

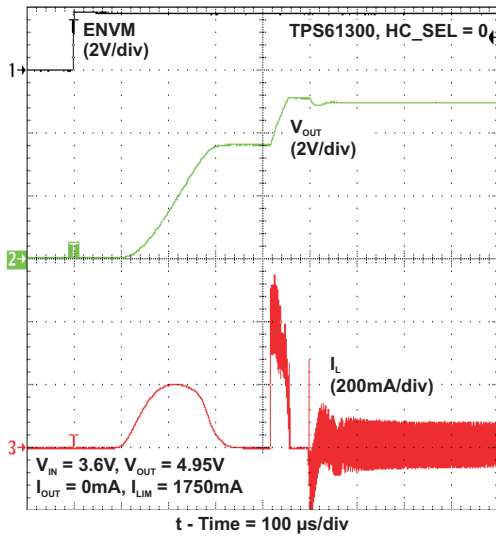

Figure 44. START-UP INTO VOLTAGE MODE OPERATION

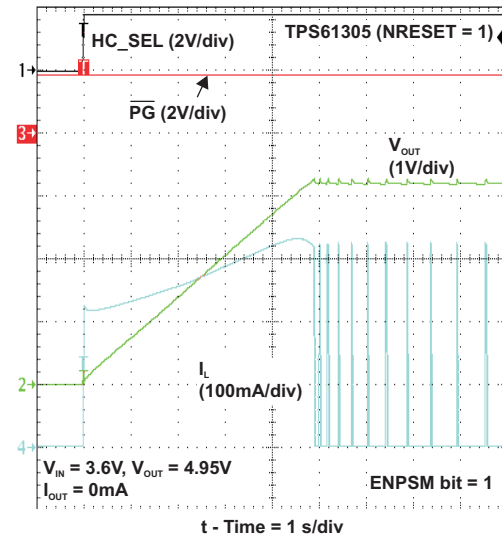

Figure 45. STORAGE CAPACITOR PRE-CHARGE (HC\_SEL=1)

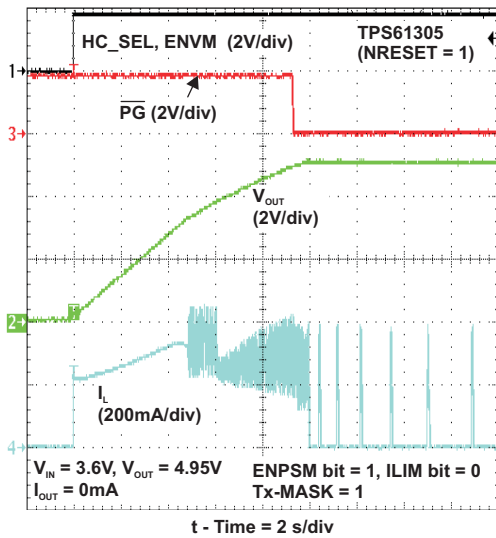

Figure 46. STORAGE CAPACITOR CHARGE-UP (HC\_SEL=1)

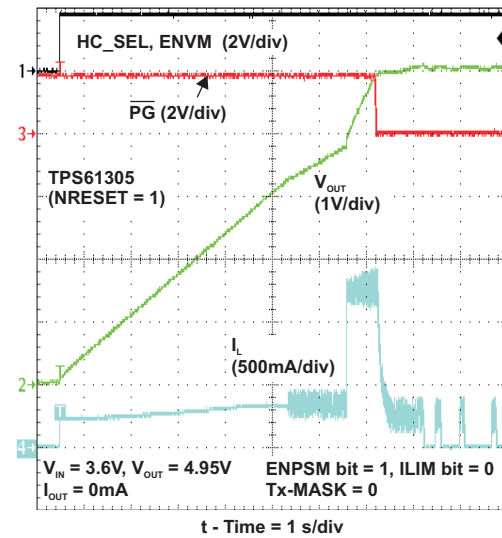

Figure 47. STORAGE CAPACITOR CHARGE-UP (HC\_SEL=1)

TYPICAL CHARACTERISTICS (continued)

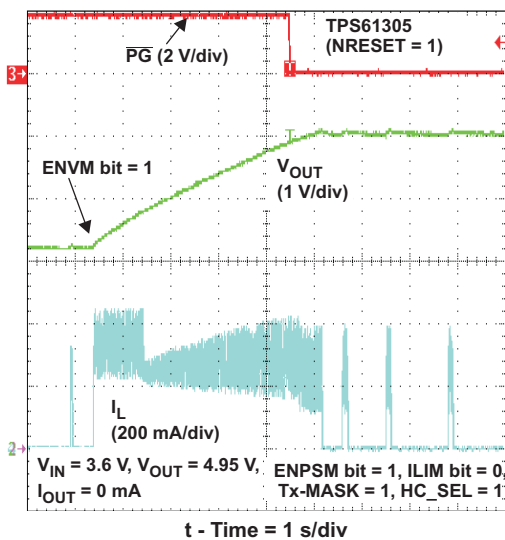

Figure 48. STORAGE CAPACITOR CHARGE-UP (HC\_SEL=1)

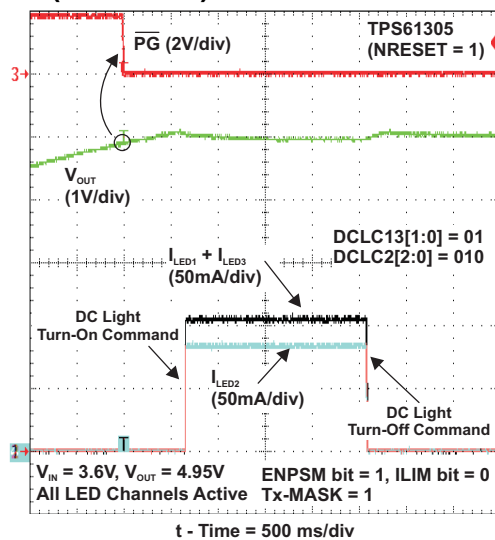

Figure 49. DC LIGHT OPERATION (HC\_SEL=1)

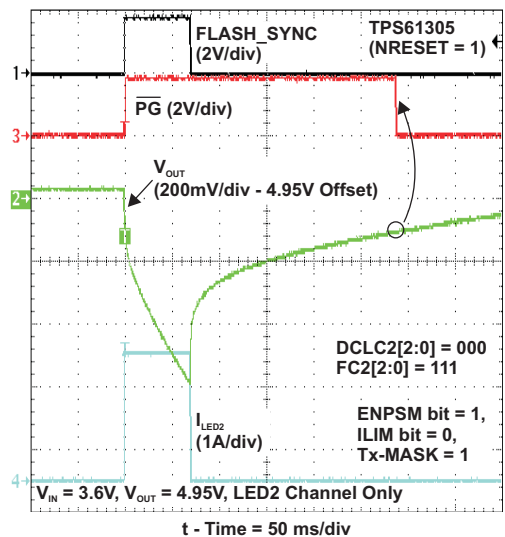

Figure 50. FLASH SEQUENCE (HC\_SEL=1)

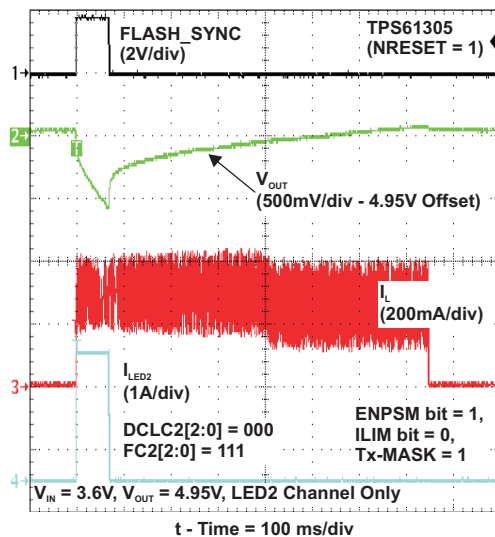

Figure 51. FLASH SEQUENCE (HC\_SEL=1)

TYPICAL CHARACTERISTICS (continued)

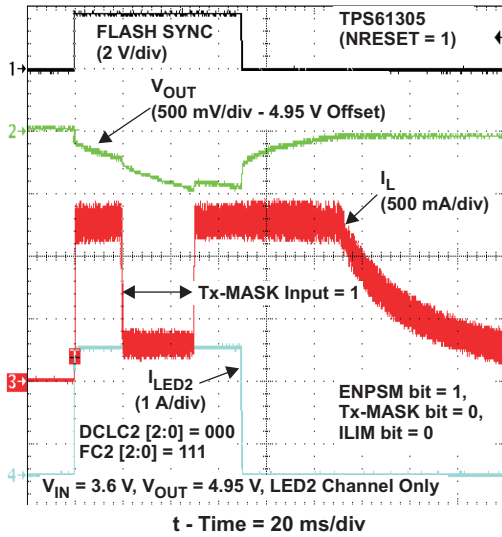

Figure 52. FLASH SEQUENCE (HC\_SEL=1)

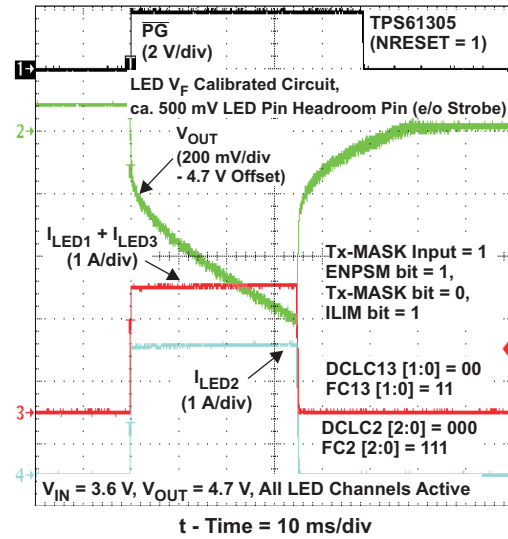

Figure 53. FLASH SEQUENCE (HC\_SEL=1)

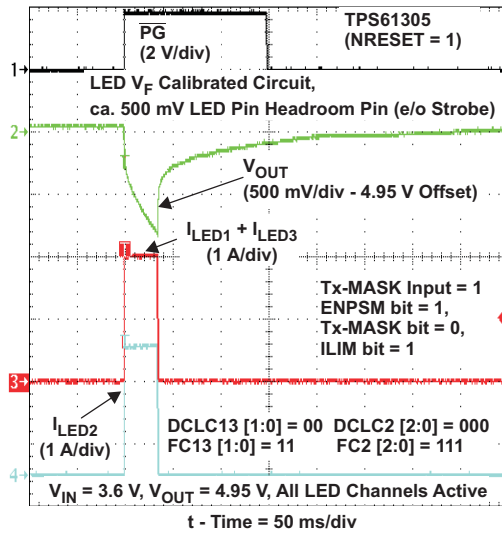

Figure 54. FLASH SEQUENCE (HC\_SEL=1)

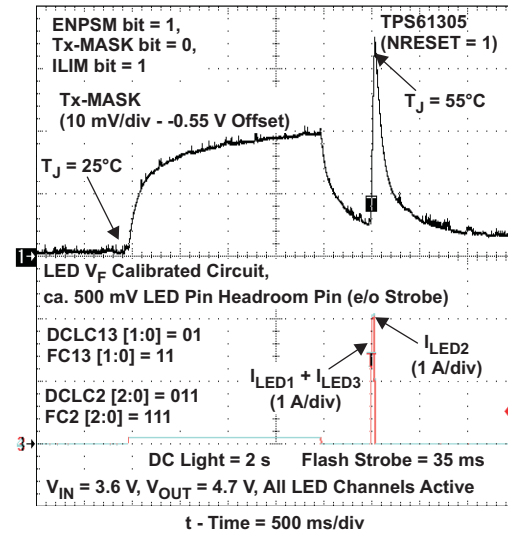

Figure 55. JUNCTION TEMPERATURE MONITORING (HC\_SEL=1)



TYPICAL CHARACTERISTICS (continued)

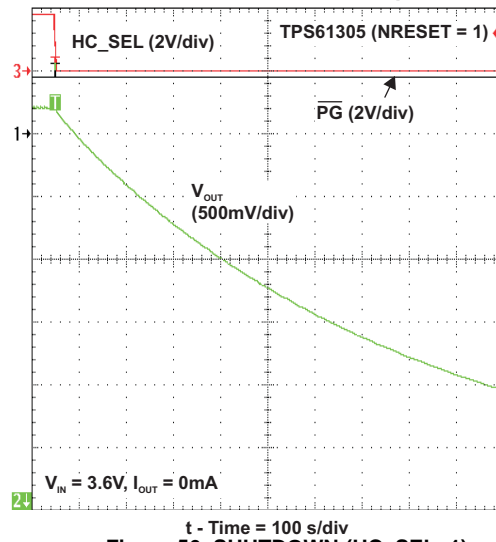

Figure 56. SHUTDOWN (HC\_SEL=1)

## DETAILED DESCRIPTION

### OPERATION

The TPS6130x family employs a 2MHz fixed on-time, PWM current-mode converter to generate the output voltage required to drive up to three high power LEDs in parallel. The device integrates a power stage based on an NMOS switch and a synchronous PMOS rectifier. The device also implements a set of linear low-side current regulators to control the LED current when the battery voltage is higher than the diode forward voltage.

A special circuit is applied to disconnect the load from the battery during shutdown of the converter. In conventional synchronous rectifier circuits, the back-gate diode of the high-side PMOS is forward biased in shutdown and allows current flowing from the battery to the output. This device however uses a special circuit which takes the cathode of the back-gate diode of the high-side PMOS and disconnects it from the source when the regulator is in shutdown (HC\_SEL = L).

The TPS6130x device cannot only operate as a regulated current source but also as a standard voltage boost regulator featuring power-save mode for improved efficiency at light load. The voltage mode operation can be activated either by a software command or by means of a hardware signal (ENVM). This additional operating mode can be useful to properly synchronize the converter when supplying other high power consuming devices in the system (e.g. hands-free audio power amplifier...) or any other component requiring a supply voltage higher than the battery voltage.

The TPS6130x device also supports storage capacitor on its output (so called energy storage mode). In this operating mode (HC\_SEL = H), the inductive power stage is used to charge-up the super-capacitor to a user selectable value. Once the charge-up is complete, the LEDs can be fired up to 1025mA (LED1 and LED3) and 2050mA (LED2) without causing a battery overload.

In general, a boost converter only regulates output voltages which are higher than the input voltage. This device operates differently. For example, in the voltage mode operation the device is capable to regulate 4.2V at the output from a battery voltage pulsing as high 5.5V. To control these applications properly, a down conversion mode is implemented.

If the input voltage reaches or exceeds the output voltage, the converter changes to a down conversion mode. In this mode, the control circuit changes the behavior of the rectifying PMOS. It sets the voltage drop across the PMOS as high as needed to regulate the output voltage. This means the power losses in the converter increase. This has to be taken into account for thermal consideration.

In direct drive mode (HC\_SEL = L), the power stage is capable of supplying a maximum total current of roughly 1300 to 1500mA. The TPS61300 provides three constant current inputs, capable of sinking up to 400mA (LED1 and LED3) and 800mA (LED2) in flashlight mode.

The TPS6130x integrates an I<sup>2</sup>C compatible interface allowing transfers up to 3.4Mbits/s. This communication interface can be used to set the operating mode (shutdown, constant output current mode vs. constant output voltage mode), to control the brightness of the external LED (DC light and flashlight modes), to adjust the output voltage (between 3.825V and 5.7V in 125mV steps) or to program the safety timer for instance. For more details, refer to the I<sup>2</sup>C register description section.

In the TPS6130x device, the DC light and flash can be controlled either by the I<sup>2</sup>C interface or by the means of hardware control signals (ENDCL and FLASH\_SYNC). To simplify flashlight synchronization with the camera module, the device offers a FLASH\_SYNC strobe input pin to turn, with zero latency, the LED current from DC light to flashlight.

The maximum duration of the flashlight pulse can be limited by means of an internal user programmable safety timer (STIM). To avoid the LEDs to be kept accidentally on in DC light mode by software control, the device implements a 11.2s watchdog timer.

## DOWN MODE IN VOLTAGE REGULATION MODE

In general, a boost converter only regulates output voltages which are higher than the input voltage. The featured devices come with the ability to regulate 4.2 V at the output with an input voltage being as high as 5.5V. To control these applications properly, a down conversion mode is implemented.

In voltage regulation mode, if the input voltage reaches or exceeds the output voltage, the converter changes to the down-conversion mode. In this mode, the control circuit changes the behavior of the rectifying PMOS. It sets the voltage drop across the PMOS as high as needed to regulate the output voltage. This means the power losses in the converter increase. This has to be taken into account for thermal consideration. The down conversion mode is automatically turned-off as soon as the input voltage falls about 200mV below the output voltage.

For proper operation in down conversion mode the output voltage should not be programmed higher than ca. 5.3V. Care should be taken not to violate the absolute maximum ratings at the SW pins.

The TPS6130x device uses a control architecture that allows to “recycle” excessive energy that might be stored in the output capacitor. By reversing the operation of the boost power stage, the converter is capable of transferring energy from its output back into the input source.

In high-current mode (HC\_SEL = 1), this feature becomes useful to dynamically adjust the output voltage ( $V_{OUT}$ ) depending on the operating conditions (e.g. +4.95V constant output voltage to support audio applications or variable storage capacitor pre-charge voltage, refer to “storage capacitor pre-charge voltage calibration” section).

Notice that this reverse operating mode can only perform within an output voltage range higher than the input supply. For example, if the storage capacitor is initially pre-charged to 4.95V, the input voltage is around 4.1V and the target output voltage is set to 3.825V, the converter will only be able to lower the output node down to the input level.

## LED HIGH-CURRENT REGULATORS, UNUSED INPUTS

The TPS6130x device utilizes LED forward voltage sensing circuitry on LED1-3 pins to optimize the power stage boost ratio for maximum efficiency. Due to the nature of the sensing circuitry, it is not recommended to leave any of the LED1-3 pins unused if the operation has been selected via ENLED[3:1] bits. Leaving LED1-3 pins unconnected, whilst the respective ENLEDx bits have been set, will force the control loop into high gain and eventually trip the output over-voltage protection.

The LED1-3 inputs may be connected together to drive one or two LEDs at higher currents. Connecting the current sink inputs in parallel does not affect the internal operation of the TPS6130x. For best operation, it is recommended to disabled the LED inputs that are not used (refer to ENLED[3:1] bits description).

To achieve smooth LED current waveforms, the TPS61300 device actively controls the LED current ramp-up/down sequence.

**Table 1. LED Current Ramp-Up/Down Control vs Operating Mode**

	DIRECT DRIVE MODE (HC_SEL = 0)	HIGH-CURRENT MODE (HC_SEL = 1)
LED CURRENT RAMP-UP	$I_{STEP} = 25 \text{ mA}$	$I_{STEP} = 56.25 \text{ mA}$
	$t_{RISE} = 12 \mu\text{s}$	$t_{RISE} = 0.5 \mu\text{s}$
	Slew-rate $\neq 2.08 \text{ mA}/\mu\text{s}$	Slew-rate $\neq 112.5 \text{ mA}/\mu\text{s}$
LED CURRENT RAMP-DOWN	$I_{STEP} = 25 \text{ mA}$	$I_{STEP} = 56.25 \text{ mA}$
	$t_{FALL} = 0.5 \mu\text{s}$	$t_{FALL} = 0.5 \mu\text{s}$
	Slew-rate $\neq 50 \text{ mA}/\mu\text{s}$	Slew-rate $\neq 112.5 \text{ mA}/\mu\text{s}$

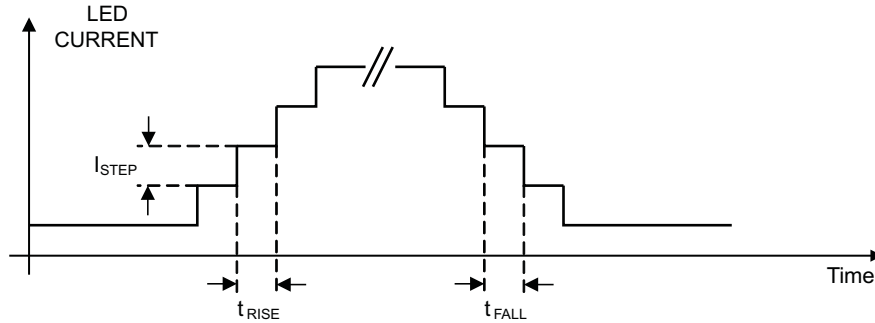
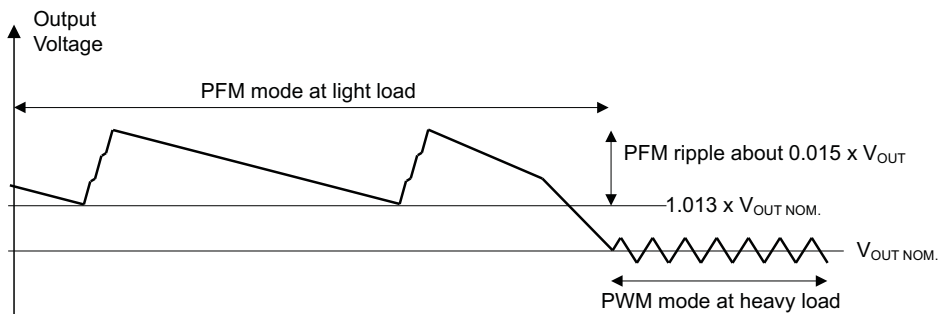

**Figure 57. LED Current Slew-Rate Control**

In high-current mode (HC\_SEL = 1), the LED current settings are defined as a fixed ratio (x2.25) versus the direct drive mode values (HC\_SEL = L).

**POWER-SAVE MODE OPERATION, EFFICIENCY**

The TPS6130x device integrates a power save mode to improve efficiency at light load. In power save mode the converter only operates when the output voltage trips below a set threshold voltage. It ramps up the output voltage with one or several pulses and goes again into power save mode once the output voltage exceeds the set threshold voltage.



**Figure 58. Operation in PFM Mode and Transfer to PWM Mode**

The power save mode can be enabled and disabled via the ENPSM bit. In down conversion mode, power save mode is always active and the device cannot be forced into fixed frequency operation at light loads.

The LED sense voltage has a direct effect on the converter’s efficiency. Because the voltage across the low-side current regulator does not contribute to the output power (LED brightness), the lower the sense voltage the higher the efficiency will be.

In direct drive mode (HC\_SEL = L), the energy is being directly transferred from the battery to the LEDs. The integrated current control loop automatically selects the minimum boosting ratio to maintain regulation based on the LED forward voltage and current requirements. The low-side current regulators will be dropping the voltage difference between the input voltage and the LEDs forward voltage ( $V_{F(LED)} < V_{IN}$ ). When running in boost mode ( $V_{F(LED)} > V_{IN}$ ), the voltage present at the LED1-3 pins of the low-side current regulators will be typically 400mV leading to high power conversion efficiency. Depending on the input voltage and the LEDs forward voltage characteristic the converter will show efficiency in the range of about 75% to 90%.

In high-current mode (HC\_SEL = H), the device is only supplying a limited amount of energy directly from the battery (i.e. DC light, contribution to flash current or voltage regulation mode). During a flash strobe, the bulk of the energy supplied to the LEDs is provided by the reservoir capacitor. The low-side current regulators will be typically operating with 400mV headroom voltage. This means the power losses in the device increase and special care should be taken for thermal considerations.

## MODE OF OPERATION: DC LIGHT AND FLASHLIGHT

Operation is understood best by referring to the timer block diagram. Depending on the settings of MODE\_CTRL[1:0] bits the device can enter 4 different operating modes. The below section details the converter's operation for ENVM = 0.

- MODE\_CTRL[1:0] = 00: The device is in shutdown mode.
- MODE\_CTRL[1:0] = 01: The device is regulating the LED current to the DC light current level (DCLC bits) regardless of the FLASH\_SYNC input and START\_FLASH/TIMER (SFT) bit. To avoid device shutdown by DC light safety timeout, MODE\_CTRL[1:0] needs to be refreshed within less than 11.2s.
- MODE\_CTRL[1:0] = 11: The device is regulating a constant output voltage according to OV[3:0] bits settings. The low-side LED1-3 current sinks are disabled and the LEDs are disconnected from the output. In this operating mode, the safety timer is disabled.
- MODE\_CTRL[1:0] = 10: The flashlight pulse can be either trigger by a hardware signal (FLASH\_SYNC) or by a software bit (SFT). LED strobe pulse follows FLASH\_SYNC.

### FLASH STROBE IS LEVEL SENSITIVE (STT = 0): LED STROBE FOLLOWS FLASH\_SYNC INPUT

FLASH\_SYNC and (SFT) = 0: LED operation is set to the DC light current level. To avoid device shutdown by DC light safety timeout, MODE\_CTRL[1:0] needs to be refreshed within less than 11.2s.

FLASH\_SYNC or (SFT) = 1: The LED is driven at the flashlight current level and the safety timer is running. The maximum duration of the flashlight pulse is defined in the STIM[2:0] register.

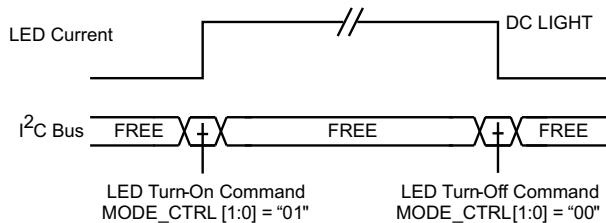

Figure 59. DC Light Operation

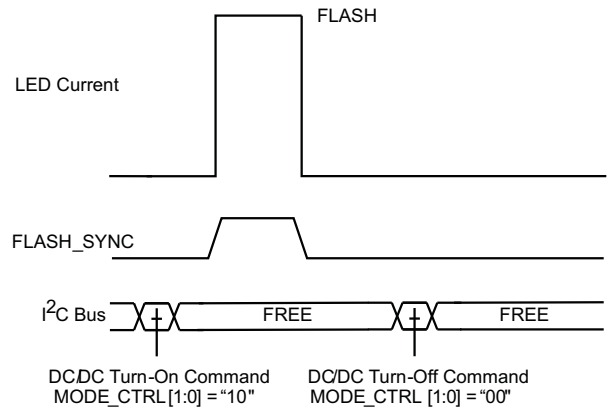

Figure 60. Synchronized Flashlight Strobe

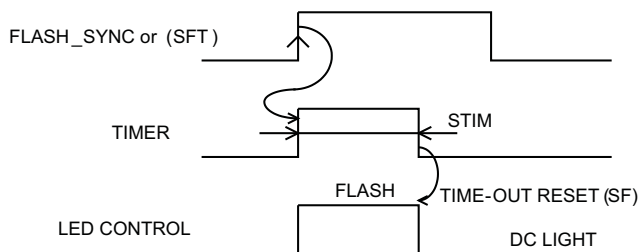

Figure 61. Level Sensitive Safety Timer (Timeout)

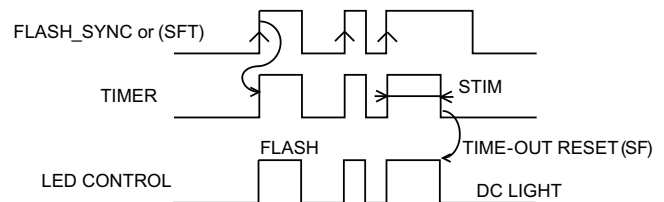

Figure 62. Level Sensitive Safety Timer (Normal Operation + Timeout)

The safety timer is started by:

- a rising edge of FLASH\_SYNC signal.
- a rising edge of START\_FLASH/TIMER (SFT) bit.

The safety timer is stopped by:

- a low level of FLASH\_SYNC signal or START\_FLASH/TIMER (SFT) bit.
- a timeout signal (TO).

START-FLASH/TIMER (SFT) bit is being reset by the timeout (TO) signal.

**FLASH STROBE IS LEADING EDGE SENSITIVE (STT = 1): ONE-SHOT LED STROBE**

When FLASH\_SYNC and START\_FLASH/TIMER (SFT) are both low the LED operation is set to the DC Light current level. To avoid device shutdown by DC light safety timeout, MODE\_CTRL[1:0] needs to be refreshed within less than 11.2s.

The duration of the flashlight pulse is defined in the STIM register. The flashlight strobe is started by:

- a rising edge of START\_FLASH/TIMER (SFT) bit.
- a rising edge of FLASH\_SYNC signal.

Once running, the timer ignores all kind of triggering signal and only stops after a timeout (TO). START-FLASH/TIMER (SFT) bit is being reset by the timeout (TO) signal.

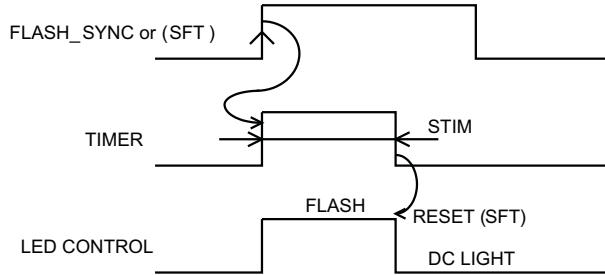

**Figure 63. Edge Sensitive Timer (Single Trigger Event)**

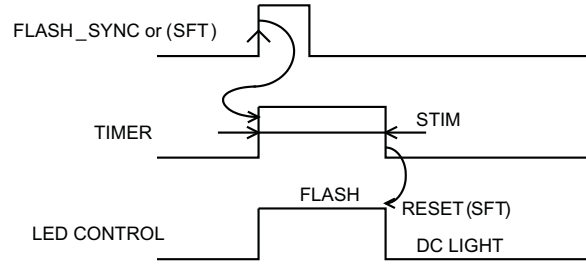

**Figure 64. Edge Sensitive Timer (Single Trigger Event)**

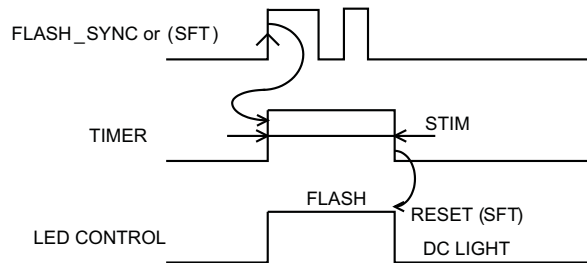

**Figure 65. Edge Sensitive Timer (Multiple Trigger Events)**

**SAFETY TIMER ACCURACY**

The LED strobe timer uses the internal oscillator as reference clock. As a matter of fact, the timer execution speed (refer to STIM[2:0]) scales according to the reference clock accuracy.

OSCILLATOR FREQUENCY	SAFETY TIMER DURATION
Minimum	Maximum = Typical × (1 + f <sub>ACC</sub> ) <sup>(1)</sup>
Typical	Typical <sup>(2)</sup>
Maximum	Minimum = Typical × (1 - f <sub>ACC</sub> ) <sup>(1)</sup>

(1) Refer to REGISTER3, STIM[2:0] definition.  
 (2) Refer to the Electrical Characteristics table.

## CURRENT LIMIT OPERATION

The current limit circuit employs a valley current sensing scheme. Current limit detection occurs during the off time through sensing of the voltage drop across the synchronous rectifier. The detection threshold is user selectable via the ILIM bit. The ILIM bit can only be set before the device enters operation (i.e., initial shutdown state).

Figure 66 illustrates the inductor and rectifier current waveforms during current limit operation. The output current,  $I_{OUT}$ , is the average of the rectifier ripple current waveform. When the load current is increased such that the lower peak is above the current limit threshold, the off time is lengthened to allow the current to decrease to this threshold before the next on-time begins (so called frequency fold-back mechanism).

Both the output voltage and the switching frequency are reduced as the power stage of the device operates in a constant current mode. The maximum continuous output current ( $I_{OUT(CL)}$ ), before entering current limit operation, can be defined as:

$$I_{OUT(CL)} = (1 - D) \times (I_{VALLEY} + \frac{1}{2} \Delta I_L) \text{ with } \Delta I_L = \frac{V_{IN}}{L} \times \frac{D}{f} \text{ and } D \approx \frac{V_{OUT} - V_{IN}}{V_{OUT}} \quad (1)$$

The TPS6130x device also provides a negative current limit (c.a. 300mA) to prevent an excessive reverse inductor current when the power stage sinks current from the output (i.e., storage capacitor) in the forced continuous conduction mode.

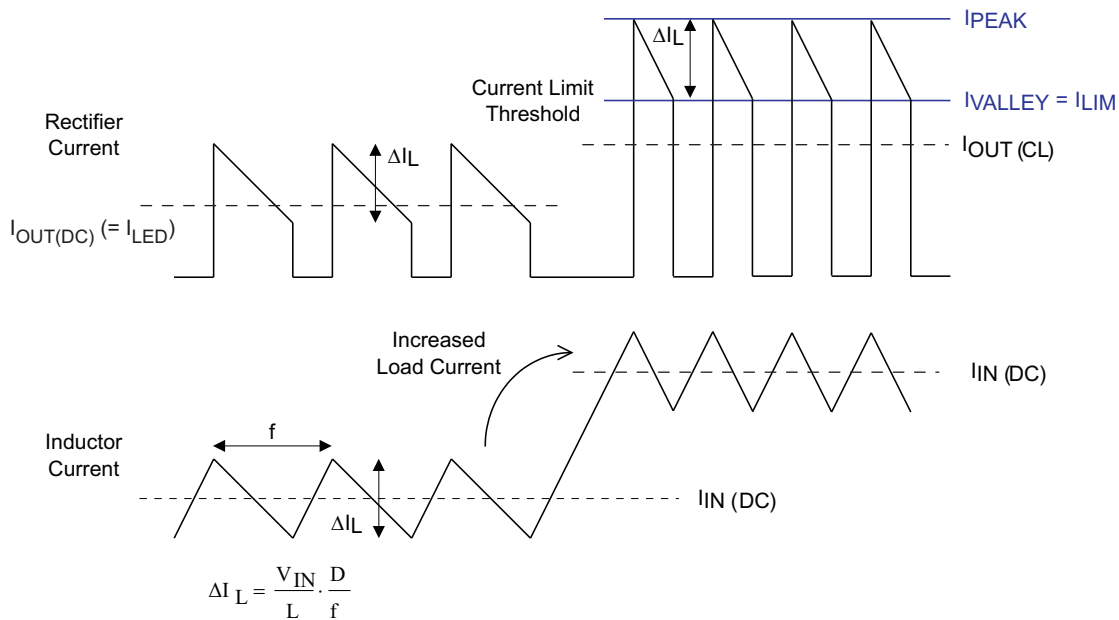

Figure 66. Inductor/Rectifier Currents in Current Limit Operation

To minimize the requirements on the energy storage capacitor present at the output of the driver ( $HC\_SEL = 1$ ), the TPS6130x device can contribute to a larger extent in supporting directly the high-current LED flash strobe. In fact, the device can dynamically adjust its current limit setting according to the Tx-MASK input.

**Table 2. Inductor Current Limit Operation vs HC\_SEL/Tx-MASK Inputs**

CURRENT LIMIT SETTING	ILIM BIT	HC_SEL INPUT	Tx-MASK INPUT
1250 mA	Low	Low	Low
1750 mA	High	Low	Low
1250 mA	Low	High	Low
1750 mA	High	High	Low
1250 mA	Low	Low	High
1750 mA	High	Low	High
250 mA	Low	High	High
500 mA	High	High	High

**LED FAILURE MODES AND OVER-VOLTAGE PROTECTION**

If a high-power LED fails as a short circuit, the low-side current regulator will limit the maximum output current and the HIGH-POWER LED FAILURE (HPLF) flag will be set.

If a high-power LED fails as an open circuit, the control loop will initially attempt to regulate off of its low-side current regulator feedback signal. This will drive V<sub>OUT</sub> higher. As the open circuited LED will never accept its programmed current, V<sub>OUT</sub> must be voltage-limited by means of a secondary control loop.

The TPS6130x device limits V<sub>OUT</sub> according to the over-voltage protection settings (refer to OVP specification). In this failure mode, V<sub>OUT</sub> is either limited to 4.65V (typ.) or 6.0V (typ.) and the HIGH-POWER LED FAILURE (HPLF) flag is set.

OVP THRESHOLD	OPERATING CONDITIONS
4.65 V typ	HC_SEL = L and 0000 ≤ OV[3:0] ≤ 0100
6.0 V typ	HC_SEL = H or 0101 ≤ OV[3:0] ≤ 1111

Refer to the section “LED High-Current Regulators, Unused inputs” for additional information.

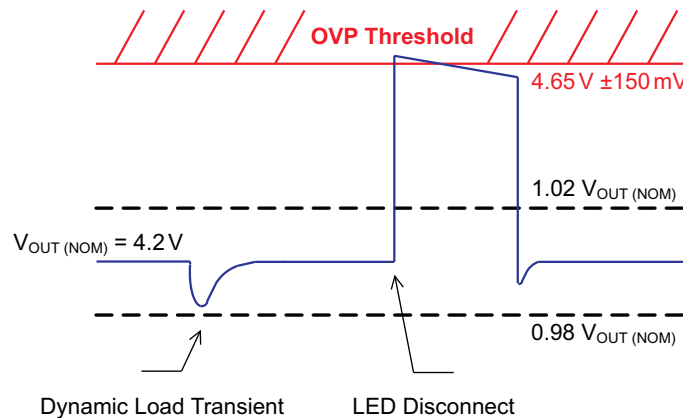

**Figure 67. Over-Voltage Protection Operation (4.65V typ)**

**HARDWARE VOLTAGE MODE SELECTION**

The TPS6130x device integrates a logic input (ENVM) and/or a software control bit (ENVM bit) that can be used to force the converter to run in voltage mode regulation. Pulling the ENVM pin high forces the device into voltage regulation mode (V<sub>OUT</sub> is preset to a fixed value, 4.95V). This additional operating mode can be useful to supply other high power consuming devices in the system (e.g., hands-free audio power amplifier...) or any other component requiring a regulated supply voltage higher or lower than the battery voltage.

Table 3 gives an overview of the different mode of operation.



**Table 3. Operating Mode Description**

INTERNAL REGISTER SETTINGS MODE_CTRL[1:0]	ENVM BIT	OPERATING MODES
00	0	The converter is in shutdown mode and the load is disconnected from the battery.
01	0	<b>LEDs are turned-on for DC light operation (i.e. movie-light).</b> The converter is operating in the current regulation mode (CM). The output voltage is controlled by the forward voltage characteristic of the LED. The energy is being directly transferred from the battery to the output.
10	0	The converter is operating in the current regulation mode (CM). The output voltage is controlled by the forward voltage characteristic of the LED. LEDs are ready for flashlight operation and DC light operation is supported directly from the battery.  <b>In high-current mode (HC_SEL = H), the energy is supplied by the output reservoir capacitor and the inductive power stage is turned-off for the flash strobe period of time.</b>
11	0	LEDs are turned-off and the converter is operating in the voltage regulation mode (VM). The output voltage is set via the register OV[3:0].
00	1	LEDs are turned-off and the converter is operating in the voltage regulation mode (VM). The output voltage is set via the register OV[3:0].
01	1	<b>The converter is operating in the voltage regulation mode (VM) and it's output voltage is set via the register OV[3:0]. The LEDs are turned-on for DC light operation and the energy is being directly transferred from the battery to the output. The LED currents are regulated by the means of the low-side current sinks.</b>
10	1	The converter is operating in the voltage regulation mode (VM) and it's output voltage is set via the register OV[3:0]. The LED currents are regulated by the means of the low-side current sinks. The LEDs are ready for flashlight operation.  In direct drive mode (HC_SEL = L), the energy is being directly transferred from the battery to the output.  <b>In high-current mode (HC_SEL = H), the energy is largely supplied by the output reservoir capacitor. The inductive power stage is turned-on to support DC light operation and to contribute the flash strobe itself.</b>
11	1	LEDs are turned-off and the converter is operating in the voltage regulation mode (VM). The output voltage is set via the register OV[3:0].

## START-UP SEQUENCE

To avoid high inrush current during start-up, special care is taken to control the inrush current. When the device enables, the internal startup cycle starts with the first step, the pre-charge phase.

During pre-charge, the rectifying switch is turned on until the output capacitor is either charged to a value close to the input voltage or ca. 3.3V, whichever occurs first. The rectifying switch is current limited during that phase. The current limit increases with decreasing input to output voltage difference. This circuit also limits the output current under short-circuit conditions at the output. [Figure 68](#) shows the typical pre-charge current vs. input minus the output voltage for a specific input voltage.

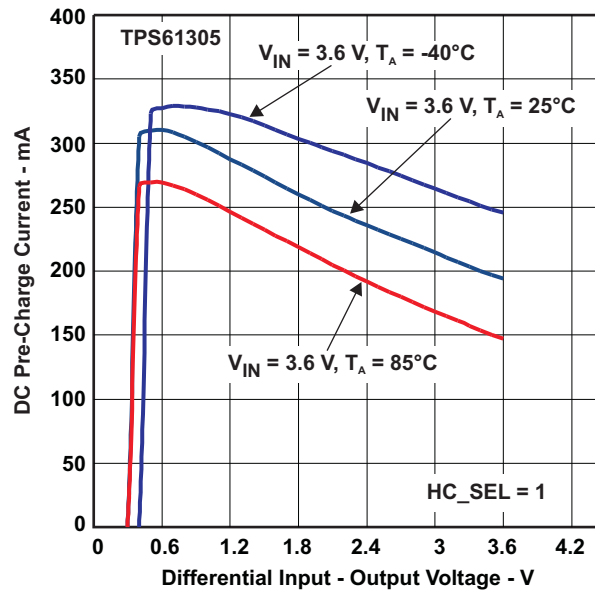

**Figure 68. Typical DC Pre-charge and Short-Circuit Current**

In direct drive mode ( $\text{HC\_SEL} = \text{L}$ , TPS6130x), after having pre-charged the output capacitor, the device starts-up switching and increases its current limit in three steps of typically 250mA, 500mA and full current limit (ILIM setting). The current limit transitions from the first to the second step occurs after a milli-second operation. Full current limit operation is set once the output voltage has reached its regulation limits. In this mode, the active balancing circuit is disabled.

In high-current mode ( $\text{HC\_SEL} = \text{H}$ ), the pre-charge voltage of the storage capacitor is depending on the input voltage and operating mode (i.e., voltage regulation vs. current regulation mode). In case the device is set for exclusive current regulation operation (i.e.,  $\text{MODE\_CTRL}[1:0] = 01$  or  $10$  and  $\text{ENVM} = 0$ ), the output capacitor pre-charge voltage will be close to the input voltage. Under all other operating conditions, the pre-charge voltage will either be close to the input voltage or to approximately 3.3V, whichever is lower.

After having pre-charged the storage capacitor, the device starts-up switching. During down-mode operation, the inductor valley current is actively limited either to 250mA or 500mA (refer to ILIM setting). As the device enters boost mode operation, the current limit transitions to its full capability (refer to ILIM setting and Tx-MASK input logic state). As a consequence, the output voltage ramps-up linearly and the start-up time needed to reach the programmed output voltage (refer to  $\text{OV}[3:0]$  bits) will mainly depend on the super-capacitor value and load current. In this mode, the active balancing circuit is enabled.

## POWER GOOD (FLASH READY)

The TPS6130x integrates a power good circuitry that is activated when the device is operating in voltage regulation mode (MODE\_CTRL[1:0] = 11 or ENVM = 1). In shutdown mode (MODE\_CTRL[1:0] = 00, ENDCL = 0 and ENVM = 0), the GPIO/PG pin state is defined as following:

GPIOTYPE	GPIO/PG SHUTDOWN STATE
0	Reset/pulled to ground
1	Open-drain

Depending on the GPIO/PG output stage type selection (i.e., push-pull or open-drain), the polarity of the power-good output signal (PG) can be inverted or not. The power-good software bit and hardware signal polarity is defined as following:

GPIOTYPE	PG BIT	GPIO/PG OUTPUT PORT	COMMENTS
0: push-pull output	0	0	Output is active high signal polarity
	1	1	
1: open-drain output	0	Open-drain	Output is active low signal polarity
	1	Low	

The power good signal is valid when the output voltage is within  $-1.5\%$  and  $+2.5\%$  of its nominal value. Conversely, it is asserted low when the voltage mode operation gets suspended (MODE\_CTRL[1:0]  $\neq$  11 and ENVM = 0).

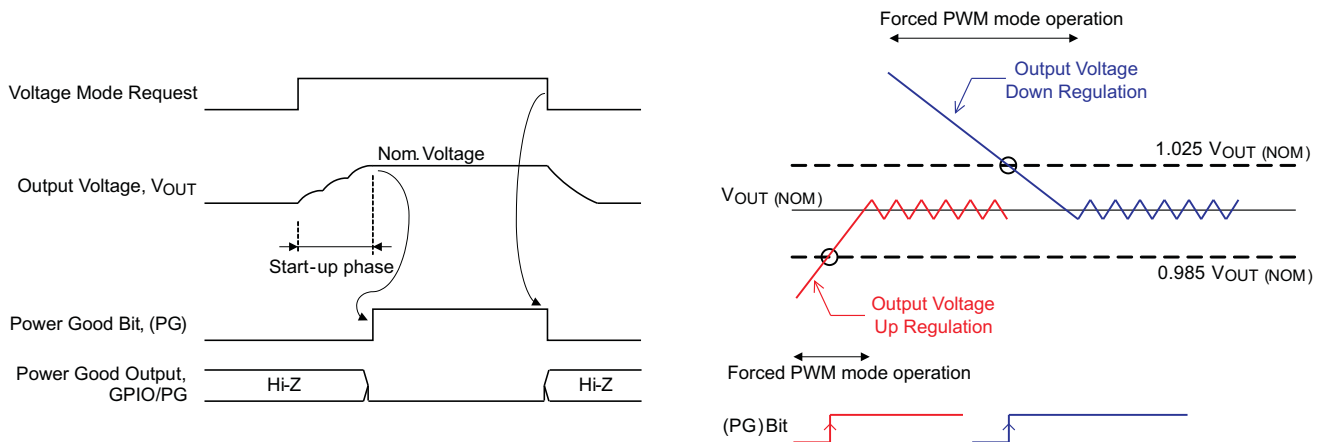

Figure 69. Power Good Operation (DIR = 1, GPIOTYPE = 1)

The TPS6130x device uses a control architecture that allows to “recycle” excessive energy that might be stored in the output capacitor. By reversing the operation of the boost power stage, the converter is capable of transferring energy from its output back into the input source. In this case, the power good signal is de-asserted whilst the output voltage is decreasing towards its target value (i.e., the closest fit voltage the converter can support, refer to the section “Down-Mode in Voltage Regulation Mode” for additional information).

## LED TEMPERATURE MONITORING (TPS61305, TPS61306)

The TPS61305 and TPS61306 devices monitor the LED temperature by measuring the voltage between the TS and AGND pins. An internal current source provides the bias (c.a. 24  $\mu$ A) for a negative-temperature coefficient resistor (NTC), and the TS pin voltage is compared to internal thresholds (1.05V and 0.345V) to protect the LEDs against overheating.

The temperature monitoring related blocks are always active in DC light or flashlight modes. In voltage mode operation (MODE\_CTRL[1:0] = 11), the device only activates the TS input when the ENTS bit is set to high. In shutdown mode, the LED temperature supervision is disabled and the quiescent current of the device is dramatically reduced.

The LEDWARN and LEDHOT bits reflect the LED temperature. The LEDWARN bit is set when the voltage seen at the TS pin is lower than 1.05V. This threshold corresponds to an LED warning temperature value, the device operation is still permitted.

While regulating LED current (i.e., DC light or flashlight modes), the LEDHOT bit is latched when the voltage seen at the TS pin is lower than 0.345V. This threshold corresponds to an excessive LED temperature value, the device operation is immediately suspended (MODE\_CTRL[1:0] bits are reset and HOTDIE[1:0] bits are set).

## HOT DIE DETECTOR

The hot die detector monitors the junction temperature but does not shutdown the device. It provides an early warning to the camera engine to avoid excessive power dissipation thus preventing from thermal shutdown during the next high-power flash strobe.

The hot die detector (HOTDIE[1:0] bits) reflects the instantaneous junction temperature and is always enabled excepted when the device is in shutdown mode (MODE\_CTRL[1:0] = 00, ENVM = 0 and ENDCL = 0).

## NRESET INPUT: HARDWARE ENABLE / DISABLE

Some devices out of the TPS6130x family feature a hardware reset pin (NRESET). This reset pin allows the device to be disabled by an external controller without requiring an I<sup>2</sup>C write command. Under normal operation, the NRESET pin should be held high to prevent an unwanted reset. When the NRESET is driven low, the I<sup>2</sup>C control interface and all internal control registers are reset to the default states and the part enters shutdown mode.

## ENDCL INPUT: DC LIGHT HARDWARE CONTROL

Some devices out of the TPS6130x family feature a dedicated DC light control input (ENDCL). This logic input can be used to turn-on the LEDs for DC light operation. This hardware control pin can be useful to control the torch light functionality from a separate engine (e.g., base-band). In this mode of operation, the DC light safety timer is not activated.

The ENDCL input is only active when the device is programmed into shutdown (MODE\_CTRL[1:0] = 00) or into voltage regulation mode (MODE\_CTRL[1:0] = 11 or ENVM = 1) and the indicator control is turned-off (INDC[3:0] = 0000). LED1-3 inputs are controlled according to ENLED[3:1] bit settings.

## FLASHLIGHT BLANKING (Tx-MASK)

In direct drive mode ( $HC\_SEL = 0$ ), the Tx-MASK input signal can be used to disable the flashlight operation, e.g., during a RF PA transmission pulse. This blanking function turns the LED from flashlight to DC light thereby reducing almost instantaneously the peak current loading from the battery. The Tx-MASK function has no influence on the safety timer duration.

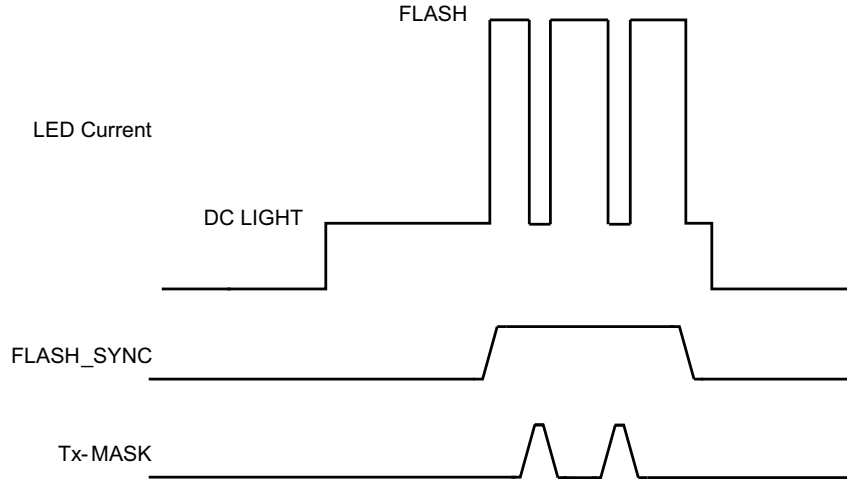

**Figure 70. Synchronized Flashlight With Blanking Periods**

In high-current mode ( $HC\_SEL = 1$ ), the Tx-MASK input pin is also used to dynamically adjust the device's current limit setting (i.e. controls the maximum current drawn from the input source). Refer to the section "Current Limit Operation" for additional information.

## UNDERVOLTAGE LOCKOUT

The under-voltage lockout circuit prevents the device from mis-operation at low input voltages. It prevents the converter from turning on the switch-MOSFET, or rectifier-MOSFET for battery voltages below 2.3V. The I2C compatible interface is fully functional down to 2.1V input voltage.

## SHUTDOWN

MODE\_CTRL[1:0] bits low force the device into shutdown. The shutdown state can only be entered when the voltage regulation and DC light modes are both turned-off ( $ENVM = 0$  and  $ENDCL = 0$ ).

In direct drive mode ( $HC\_SEL = L$ ), the regulator stops switching, the high-side PMOS disconnects the load from the input and the LEDx pins are high impedance thus eliminating any DC conduction path. The TPS6130x device actively discharges the output capacitor when it turns off.

The integrated discharge resistor has a typical resistance of 2k $\Omega$  equally split-off between V<sub>OUT</sub> to BAL and BAL to GND outputs. The required time to discharge the output capacitor at V<sub>OUT</sub> depends on load current and the effective output capacitance. The active balancing circuit is disabled and the device consumes only a shutdown current of 1 $\mu$ A (typ).

In high-current mode ( $HC\_SEL = H$ ), the device maintains its output biased at the input voltage level. In this mode, the synchronous rectifier is current limited (i.e. pre-charge current) allowing external load (e.g. audio amplifier) to be powered with a restricted supply. The active balancing circuit is enabled and the device consumes only a standby current of 5 $\mu$ A (typ).

## THERMAL SHUTDOWN

As soon as the junction temperature,  $T_J$ , exceeds 160°C typical, the device goes into thermal shutdown. In this mode, the power stage and the low-side current regulators are turned-off, the HOTDIE[1:0] bits are set and can only be reset by a readout.

In the voltage mode operation ( $\text{MODE\_CTRL}[1:0] = 11$  or  $\text{ENVM} = 1$ ), the device continues its operation when the junction temperature falls below  $140^{\circ}\text{C}$  typ. again. In the current regulation mode (i.e., DC light or flashlight modes) the device operation is suspended.

### STORAGE CAPACITOR ACTIVE CELL BALANCING

A fully charged super-capacitor will typically have leakage current of under  $1\mu\text{A}$ . The TPS6130x device integrates an active balancing feature to cut the total leakage current from the super-capacitor and balance circuit to less than  $1.7\mu\text{A}$  typ.

The device integrates a window comparator monitoring the tap point of the multi-cell super-capacitor. The balancing output (BAL) is substantially half the actual output voltage ( $V_{\text{OUT}}$ ). If the internal leakage current in one of the capacitors is larger than that in the other, then the voltage at their junction will tend to change in such a way that the voltage on the capacitor with the larger (or largest) leakage current will reduce.

When this happens, a current will begin to flow from the BAL output in such a direction as to reduce the amount by which the voltage changes. The current that will flow after a long period of steady-state conditions will be approximately equal to the difference between the leakage currents of the pair of capacitors which is being balanced by the circuit. The output resistance of the balancing circuit (c.a.  $250\Omega$ ) determines how quickly an imbalance will be corrected.

## RED LIGHT PRIVACY INDICATOR

The TPS6130x device provides a high-side linear constant current source to drive low VF LEDs. The LED current is directly regulated off the battery and can be controlled via the INDC[3:0] bits. Operation is understood best by referring to the [Figure 71](#) and [Figure 72](#).

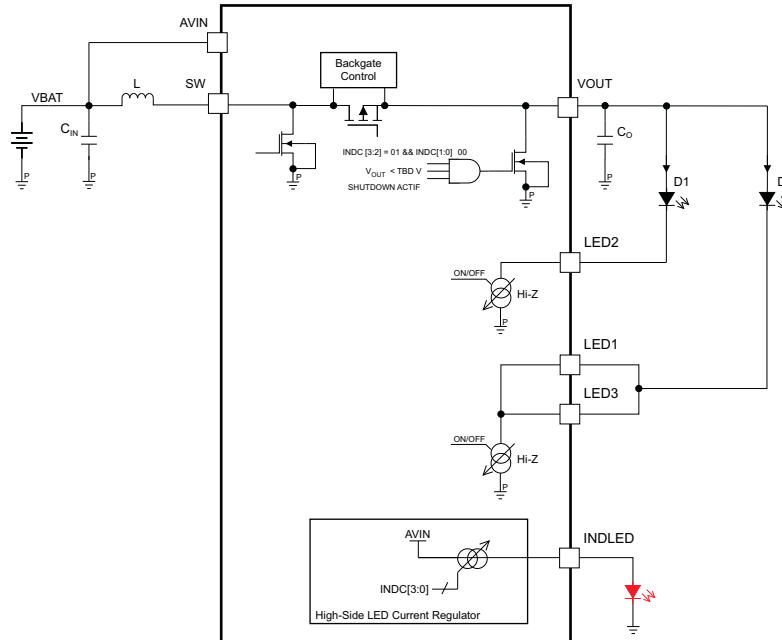

Figure 71. RED Light Indicator, Configuration 1

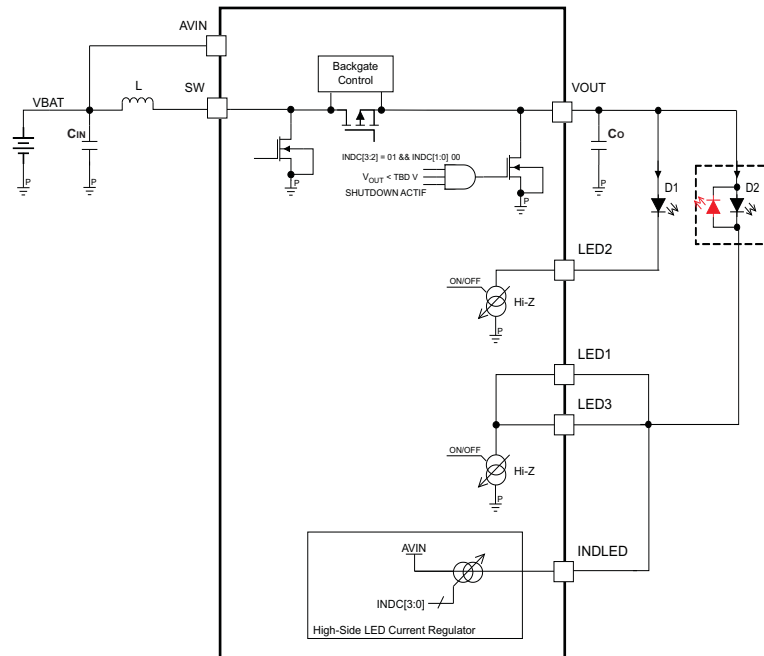

Figure 72. RED Light Indicator, Configuration 2

The device can provide a path to allow for reverse biasing of white LEDs (refer to [Figure 72](#)). To do so, the output of the converter (VOUT) is pulled to ground thus allowing a reverse current to flow. This mode of operation is only possible when the converter's power stage is in shutdown (MODE\_CTRL[1:0] = 00, ENV\_M = 0, ENDCL = 0 and HC\_SEL = 0).

### WHITE LED PRIVACY INDICATOR

The TPS6130x device features white LED drive capability at very low light intensity. To generate a reduced LED average current, the device employs a 122Hz fixed frequency PWM modulation scheme. Operation is understood best by referring to the timer block diagram.

The DC light current is modulated with a duty cycle defined by the INDC[3:0] bits. The low light dimming mode can only be activated in the software controlled DC light only mode (MODE\_CTRL[1:0] = 01, ENV\_M = X, ENDCL = 0) and applies to the LEDs selected via ENLED[3:1] bits. In this mode, the DC light safety timeout feature is disabled.

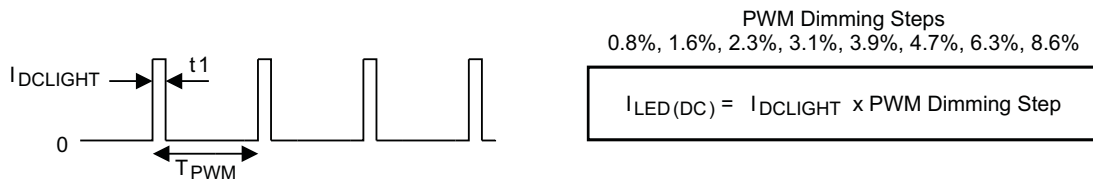

Figure 73. PWM Dimming Principle

### STORAGE CAPACITOR, PRE-CHARGE VOLTAGE CALIBRATION

High-power LEDs tend to exhibit a wide forward voltage distribution. The TPS6130x device integrates a self-calibration procedure that can be used to determine the optimum super-capacitor pre-charge voltage based on the actual worst case LED forward voltage and ESR of the storage capacitor. This calibration procedure is meant to start-off at a min. output voltage and can be initiated by setting the SELFCAL bit (preferably with MODE\_CTRL[1:0] = 00, ENV\_M = 0, ENDCL = 0).

The calibration procedure monitors the sense voltage across the low-side current regulators (according to ENLED[3:1] bits setting) and registers the worst case LED (i.e. the LED featuring the largest forward voltage). The TPS6130x device automatically sweeps through its output voltage range and performs a short duration flash strobe for each step (refer to FC13[1:0] and FC2[2:0] bits settings).

In direct drive mode (HC\_SEL = L), the energy is being directly transferred from the battery to the LEDs. In high-current mode (HC\_SEL = H), the energy is supplied exclusively by the output reservoir capacitor and the inductive power stage is turned-off for the flash strobe period of time.

The sequence is stopped as soon as the device detects that each of the low-side current regulators have enough headroom voltage (i.e. 400mV typ.). The device returns the according output voltage in the register OV[3:0] and sets the SELFCAL bit. This bit is only being reset at the (re-)start of a calibration cycle. In other words, when SELFCAL is asserted the output voltage register (OV[3:0]) returns the result of the last calibration sequence.



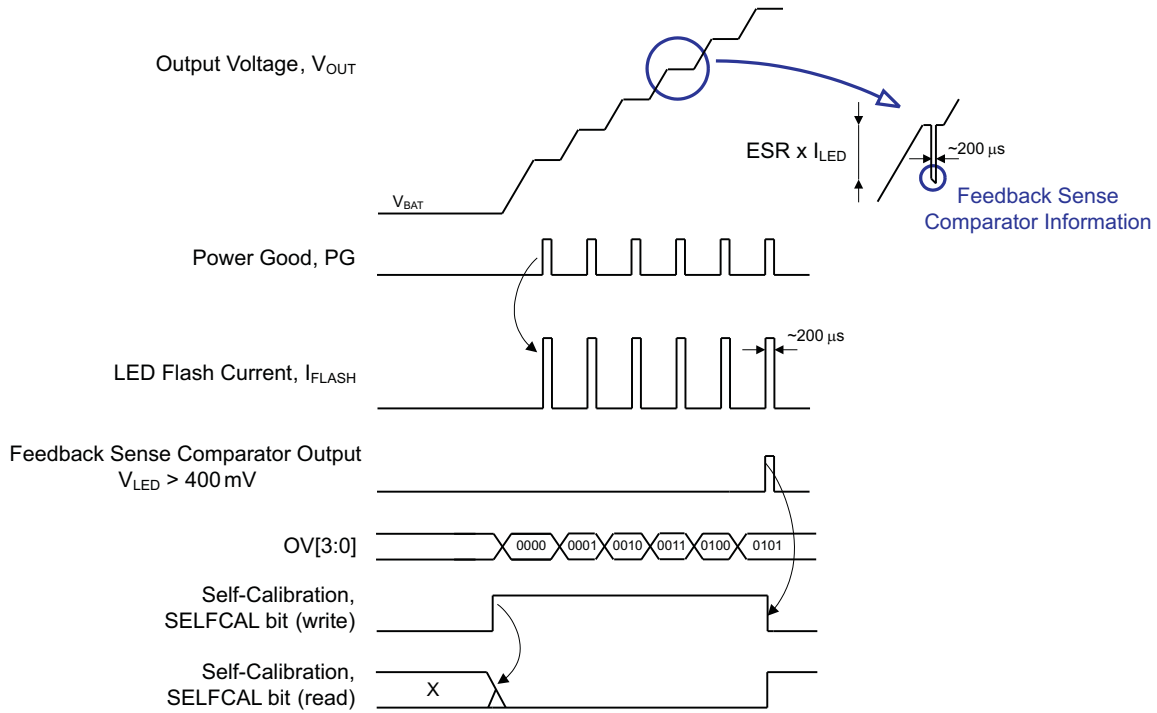

**Figure 74. LED Forward Voltage Self-Calibration Principle**

## STORAGE CAPACITOR, ADAPTIVE PRE-CHARGE VOLTAGE

In high-power LED camera flash applications, the storage capacitor is supposed to be charged to an optimum voltage level in order to:

- Maintain sufficient headroom voltage across the LED current regulators for the entire strobe time.
- Minimize the power dissipation in the device.

High-power LEDs tend to exhibit large dynamic forward voltage variation relating to own self-heating effects. In addition, the energy storage capacitor (i.e., Electrochemical Double-Layer Capacitor or Super-Capacitor) also shows a relatively large effective capacitance and ESR spread. The main factors contributing to these variations are:

- Flash strobe duration
- Temperature
- Ageing effects

In practice, it normally becomes very challenging to compensate for all these variations and a worst-case design would presumably be too pessimistic. As a consequence, designers would have to give-up on the benefits coming along with the “Storage Capacitor, Pre-Charge Voltage Calibration” approach.

The TPS6130x device offers the possibility of controlling the storage capacitor pre-charge voltage in a closed-loop manner. The principle is to dynamically adjust the initial pre-voltage to the minimum value, as required for the particular components characteristic and operating conditions.

The reference criteria used to evaluate proper operation is the headroom voltage across the LED current regulators. In case of a critical headroom voltage ( $V_{LED1-3}$ ) at the end of a flash strobe (i.e., n cycle), the pre-charge voltage should be increased prior to the next capture sequence (i.e., n+1 cycle).

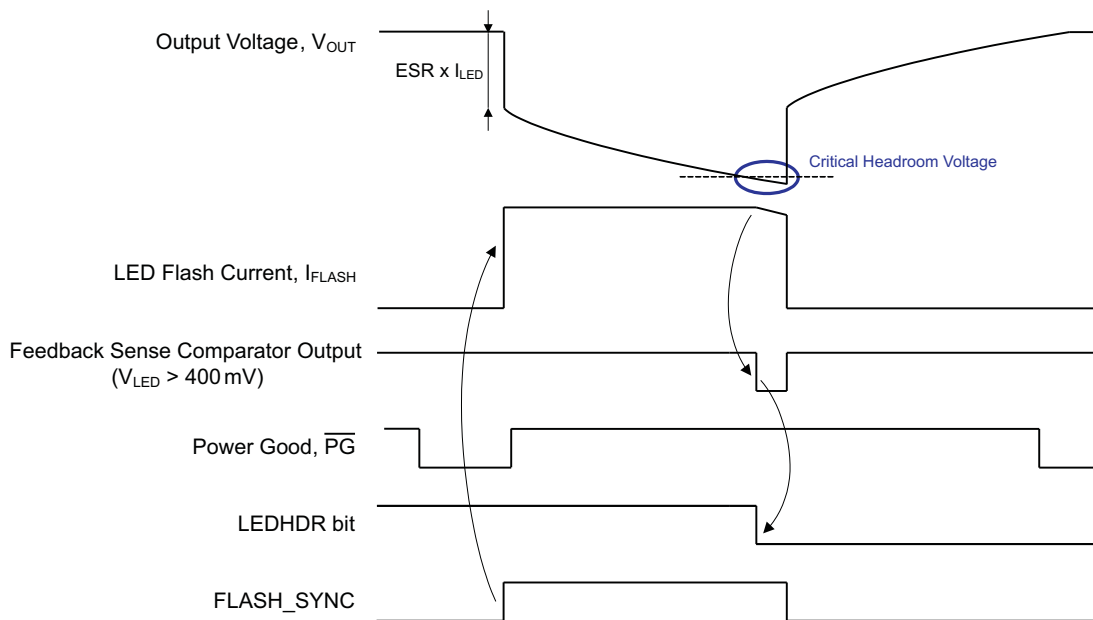

Figure 75. Storage Capacitor, Simple Adaptive Pre-Charge Voltage

## SERIAL INTERFACE DESCRIPTION

I<sup>2</sup>C™ is a 2-wire serial interface developed by Philips Semiconductor, now NXP Semiconductors (see I2C-Bus Specification, Version 2.1, January 2000). The bus consists of a data line (SDA) and a clock line (SCL) with pull-up structures. When the bus is *idle*, both SDA and SCL lines are pulled high. All the I<sup>2</sup>C compatible devices connect to the I<sup>2</sup>C bus through open drain I/O pins, SDA and SCL. A *master* device, usually a microcontroller or a digital signal processor, controls the bus. The master is responsible for generating the SCL signal and device addresses. The master also generates specific conditions that indicate the START and STOP of data transfer. A *slave* device receives and/or transmits data on the bus under control of the master device.

The TPS6130x device works as a *slave* and supports the following data transfer *modes*, as defined in the I<sup>2</sup>C-Bus Specification: standard mode (100 kbps) and fast mode (400 kbps), and high-speed mode (3.4 Mbps). The interface adds flexibility to the power supply solution, enabling most functions to be programmed to new values depending on the instantaneous application requirements. Register contents remain intact as long as supply voltage remains above 2.1V.

The data transfer protocol for standard and fast modes is exactly the same, therefore they are referred to as F/S-mode in this document. The protocol for high-speed mode is different from F/S-mode, and it is referred to as HS-mode. The TPS6130x device supports 7-bit addressing; 10-bit addressing and general call address are not supported. The device 7bit address is defined as '011 0011'.

## F/S-MODE PROTOCOL

The master initiates data transfer by generating a start condition. The start condition is when a high-to-low transition occurs on the SDA line while SCL is high, as shown in Figure 76. All I<sup>2</sup>C-compatible devices should recognize a start condition.

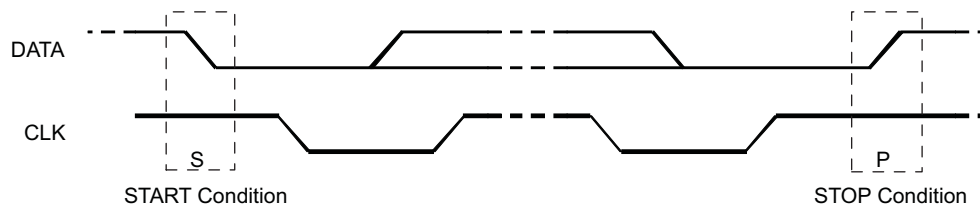

Figure 76. START and STOP Conditions

The master then generates the SCL pulses, and transmits the 7-bit address and the read/write direction bit R/W on the SDA line. During all transmissions, the master ensures that data is valid. A valid data condition requires the SDA line to be stable during the entire high period of the clock pulse (see Figure 77). All devices recognize the address sent by the master and compare it to their internal fixed addresses. Only the slave device with a matching address generates an acknowledge (see Figure 78) by pulling the SDA line low during the entire high period of the ninth SCL cycle. Upon detecting this acknowledge, the master knows that communication link with a slave has been established.

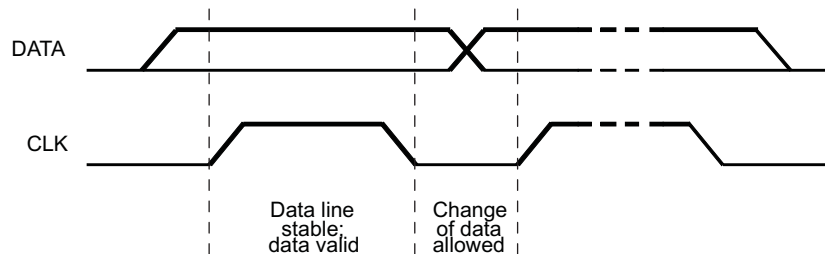

Figure 77. Bit Transfer on the Serial Interface

The master generates further SCL cycles to either transmit data to the slave (R/W bit 1) or receive data from the slave (R/W bit 0). In either case, the receiver needs to acknowledge the data sent by the transmitter. So an acknowledge signal can either be generated by the master or by the slave, depending on which one is the receiver. 9-bit valid data sequences consisting of 8-bit data and 1-bit acknowledge can continue as long as necessary.

To signal the end of the data transfer, the master generates a stop condition by pulling the SDA line from low to high while the SCL line is high (see Figure 76). This releases the bus and stops the communication link with the addressed slave. All I<sup>2</sup>C compatible devices must recognize the stop condition. Upon the receipt of a stop condition, all devices know that the bus is released, and they wait for a start condition followed by a matching address.

Attempting to read data from register addresses not listed in this section will result in 00h being read out.

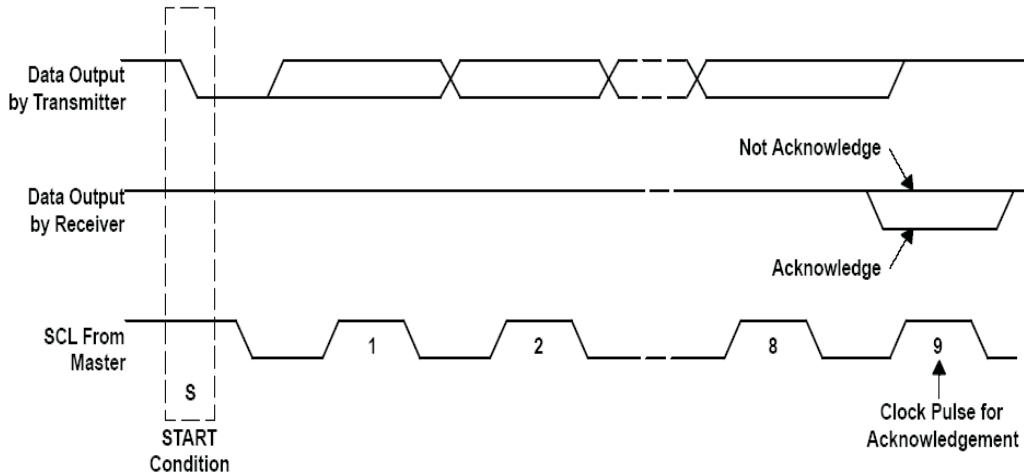

Figure 78. Acknowledge on the I<sup>2</sup>C Bus

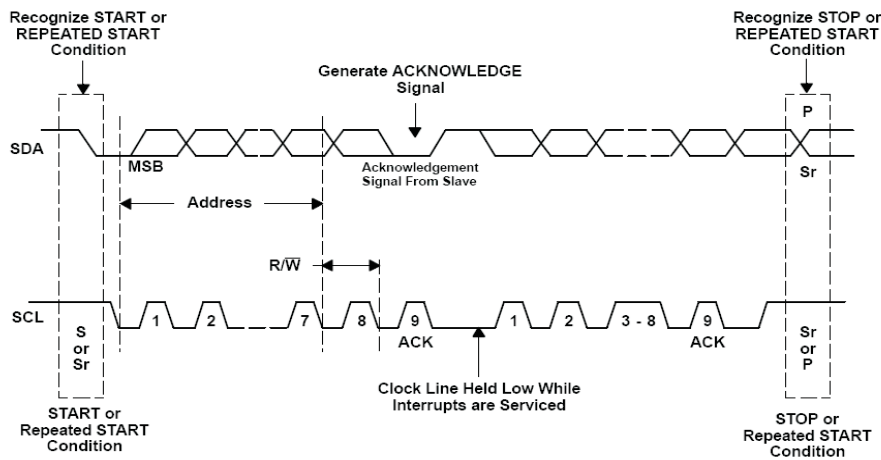

Figure 79. Bus Protocol

### HS-MODE PROTOCOL

The master generates a start condition followed by a valid serial byte containing HS master code 00001XXX. This transmission is made in F/S-mode at no more than 400 Kbps. No device is allowed to acknowledge the HS master code, but all devices must recognize it and switch their internal setting to support 3.4 Mbps operation.

The master then generates a *repeated start condition* (a repeated start condition has the same timing as the start condition). After this repeated start condition, the protocol is the same as F/S-mode, except that transmission speeds up to 3.4 Mbps are allowed. A stop condition ends the HS-mode and switches all the internal settings of the slave devices to support the F/S-mode. Instead of using a stop condition, repeated start conditions should be used to secure the bus in HS-mode.

Attempting to read data from register addresses not listed in this section will result in 00h being read out.

### TPS6130x I2C UPDATE SEQUENCE

The TPS6130x requires a start condition, a valid I<sup>2</sup>C address, a register address byte, and a data byte for a single update. After the receipt of each byte, TPS6130x device acknowledges by pulling the SDA line low during the high period of a single clock pulse. A valid I<sup>2</sup>C address selects the TPS6130x. TPS6130x performs an update on the falling edge of the acknowledge signal that follows the LSB byte.

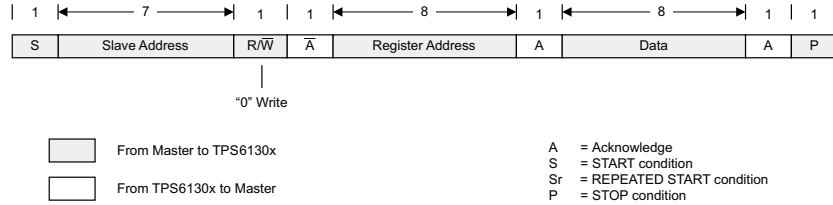

Figure 80. : “Write” Data Transfer Format in F/S-Mode

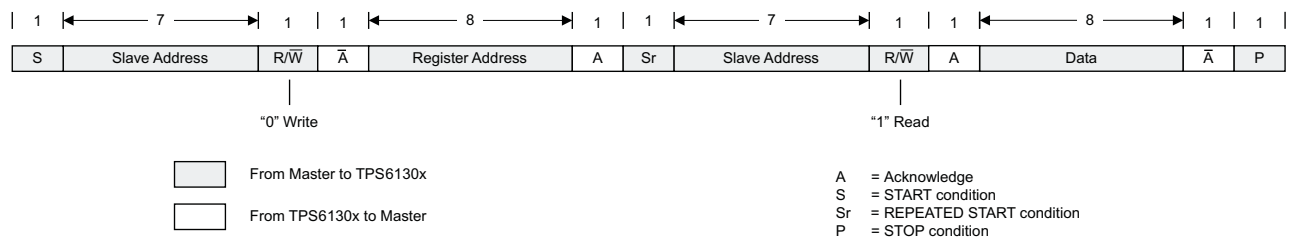

Figure 81. “Read” Data Transfer Format in F/S-Mode

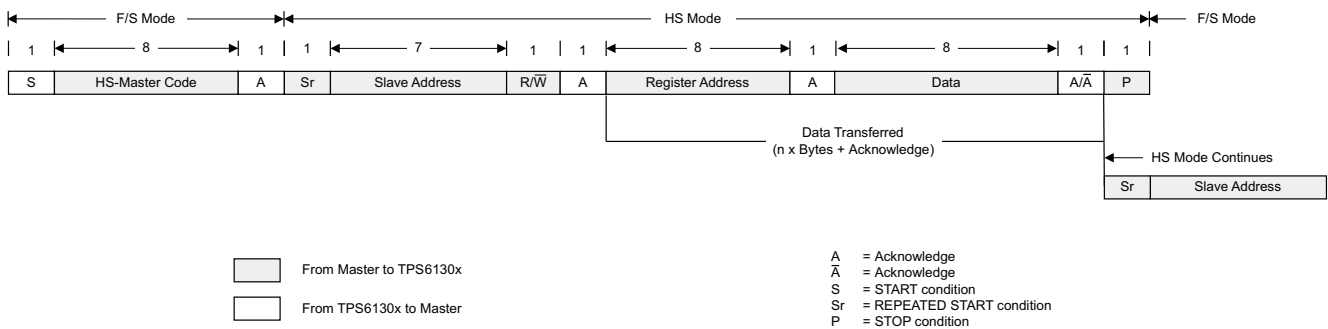

Figure 82. Data Transfer Format in H/S-Mode

### SLAVE ADDRESS BYTE

MSB							LSB
X	X	X	X	X	X	A1	A0

The slave address byte is the first byte received following the START condition from the master device.

### REGISTER ADDRESS BYTE

MSB							LSB
0	0	0	0	00	D2	D1	D0

Following the successful acknowledgement of the slave address, the bus master will send a byte to the TPS6130x, which will contain the address of the register to be accessed.

**REGISTER1 DESCRIPTION (TPS61300, TPS61301)**

Memory location: 0x01

Description	ENVM	MODE_CTRL[1:0]			DCLC13[1:0]		DCLC2[1:0]		
Bits	D7	D6	D5	D4	D3	D2	D1	D0	
Memory type	R/W	R/W	R/W	R/W	R/W	R/W	R/W	R/W	
Default value	0	0	0	0	1	0	0	1	

Bit	Description
<b>ENVM</b>	<p><b>Enable Voltage Mode bit.</b>                      0: Normal operation.                      1: Forces the device into a constant voltage source.                      In read mode, the ENVM bit is automatically updated to reflect the logic state of the ENVM input pin.</p>
<b>MODE_CTRL[1:0]</b>	<p><b>Mode Control bits.</b>                      00: Device in shutdown mode.                      01: Device operates in DC light mode.                      10: Device operates in DC light and flash mode.                      11: Device operates as constant voltage source.                      To avoid device shutdown by DC light safety timeout, MODE_CTRL[1:0] bits need to be refreshed within less than 11.2s.                      Writing to REGISTER1[6:5] automatically updates REGISTER2[6:5].</p>
<b>DCLC13[1:0]</b>	<p><b>DC Light Current Control bits (LED1/3).</b>                      00: 0mA. LEDs are off, <math>V_{OUT}</math> set according to OV[3:0].<sup>(1)</sup>                      01: 50mA                      10: 75mA                      11: 100mA</p>
<b>DCLC2[2:0]</b>	<p><b>DC Light Current Control bits (LED2).</b>                      000: 0mA. LEDs are off, <math>V_{OUT}</math> set according to OV[3:0].<sup>(1)</sup>                      001: 50mA                      010: 75mA                      011: 100mA                      100: 125mA                      101: 150mA                      110: 200mA, 350mA current level can be activated simultaneously with Tx-MASK = 1.                      111: 250mA, 500mA current level can be activated simultaneously with Tx-MASK = 1.</p>

(1) When DCLC2[2:0] and DCLC13[1:0] are both reset, the device operates in voltage regulation mode. The output voltage is set according to OV[3:0].

**REGISTER1 DESCRIPTION (TPS61305, TPS61306)**

Memory location: 0x01

Description	ENVM	MODE_CTRL[1:0]			DCLC13[1:0]		DCLC2[1:0]		
Bits	D7	D6	D5	D4	D3	D2	D1	D0	
Memory type	R/W	R/W	R/W	R/W	R/W	R/W	R/W	R/W	
Default value	0	0	0	0	1	0	0	1	

Bit	Description
<b>ENVM</b>	<b>Enable Voltage Mode bit.</b> 0: Normal operation. 1: Forces the device into a constant voltage source. In read mode, the ENVM bit is automatically updated to reflect the logic state of the ENVM input pin.
<b>MODE_CTRL[1:0]</b>	<b>Mode Control bits.</b> 00: Device in shutdown mode. 01: Device operates in DC light mode. 10: Device operates in DC light and flash mode. 11: Device operates as constant voltage source. To avoid device shutdown by DC light safety timeout, MODE_CTRL[1:0] bits need to be refreshed within less than 11.2s. Writing to REGISTER1[6:5] automatically updates REGISTER2[6:5].
<b>DCLC13[1:0]</b>	<b>DC Light Current Control bits (LED1/3).</b> 00: 0mA. LEDs are off, $V_{OUT}$ set according to OV[3:0]. <sup>(1)</sup> 01: 55mA 10: 85mA 11: 110mA
<b>DCLC2[2:0]</b>	<b>DC Light Current Control bits (LED2).</b> 000: 0mA. LEDs are off, $V_{OUT}$ set according to OV[3:0]. <sup>(1)</sup> 001: 55mA 010: 85mA 011: 110mA 100: 140mA 101: 165mA 110: 220mA, 350mA current level can be activated simultaneously with Tx-MASK = 1. 111: 275mA, 500mA current level can be activated simultaneously with Tx-MASK = 1.

(1) When DCLC2[2:0] and DCLC13[1:0] are both reset, the device operates in voltage regulation mode. The output voltage is set according to OV[3:0].

**REGISTER2 DESCRIPTION (TPS61300, TPS61301)**

Memory location: 0x02

Description	ENVM	MODE_CTRL[1:0]			FC13[1:0]		FC2[1:0]	
Bits	D7	D6	D5	D4	D3	D2	D1	D0
Memory type	R/W	R/W	R/W	R/W	R/W	R/W	R/W	R/W
Default value	0	0	0	0	0	0	1	1

Bit	Description																		
<b>ENVM</b>	<p>Enable Voltage Mode bit.</p> <p>0: Normal operation.</p> <p>1: Forces the device into a constant voltage source.</p> <p>In read mode, the ENVM bit is automatically updated to reflect the logic state of the ENVM input pin.</p>																		
<b>MODE_CTRL[1:0]</b>	<p><b>Mode Control bits.</b></p> <p>00: Device in shutdown mode.</p> <p>01: Device operates in DC light mode.</p> <p>10: Device operates in DC light and flash mode.</p> <p>11: Device operates as constant voltage source.</p> <p>To avoid device shutdown by DC light safety timeout, MODE_CTRL[1:0] bits need to be refreshed within less than 11.2s.</p> <p>Writing to REGISTER2[6:5] automatically updates REGISTER1[6:5].</p>																		
<b>FC13[1:0]</b>	<p><b>Flash Current Control bits (LED1/3).</b></p> <table border="0"> <tr> <td>HC_SEL = 0</td> <td>HC_SEL = 1</td> </tr> <tr> <td>00: 250mA</td> <td>00: 600mA</td> </tr> <tr> <td>01: 300mA</td> <td>01: 700mA</td> </tr> <tr> <td>10: 350mA</td> <td>10: 800mA</td> </tr> <tr> <td>11: 400mA</td> <td>11: 925mA</td> </tr> </table>	HC_SEL = 0	HC_SEL = 1	00: 250mA	00: 600mA	01: 300mA	01: 700mA	10: 350mA	10: 800mA	11: 400mA	11: 925mA								
HC_SEL = 0	HC_SEL = 1																		
00: 250mA	00: 600mA																		
01: 300mA	01: 700mA																		
10: 350mA	10: 800mA																		
11: 400mA	11: 925mA																		
<b>FC2[2:0]</b>	<p><b>Flash Current Control bits (LED2).</b></p> <table border="0"> <tr> <td>HC_SEL = 0</td> <td>HC_SEL = 1</td> </tr> <tr> <td>000: 275mA</td> <td>000: 650mA</td> </tr> <tr> <td>001: 300mA</td> <td>001: 700mA</td> </tr> <tr> <td>010: 350mA</td> <td>010: 825mA</td> </tr> <tr> <td>011: 450mA</td> <td>011: 1050mA</td> </tr> <tr> <td>100: 550mA</td> <td>100: 1300mA</td> </tr> <tr> <td>101: 600mA</td> <td>101: 1400mA</td> </tr> <tr> <td>110: 700mA</td> <td>110: 1600mA</td> </tr> <tr> <td>111: 800mA</td> <td>111: 1850mA</td> </tr> </table>	HC_SEL = 0	HC_SEL = 1	000: 275mA	000: 650mA	001: 300mA	001: 700mA	010: 350mA	010: 825mA	011: 450mA	011: 1050mA	100: 550mA	100: 1300mA	101: 600mA	101: 1400mA	110: 700mA	110: 1600mA	111: 800mA	111: 1850mA
HC_SEL = 0	HC_SEL = 1																		
000: 275mA	000: 650mA																		
001: 300mA	001: 700mA																		
010: 350mA	010: 825mA																		
011: 450mA	011: 1050mA																		
100: 550mA	100: 1300mA																		
101: 600mA	101: 1400mA																		
110: 700mA	110: 1600mA																		
111: 800mA	111: 1850mA																		



**REGISTER2 DESCRIPTION (TPS61305, TPS61306)**

Memory location: 0x02

Description	ENVM	MODE_CTRL[1:0]			FC13[1:0]		F2[1:0]		
Bits	D7	D6	D5	D4	D3	D2	D1	D0	
Memory type	R/W	R/W	R/W	R/W	R/W	R/W	R/W	R/W	
Default value	0	0	0	0	0	0	1	1	

Bit	Description																		
<b>ENVM</b>	Enable Voltage Mode bit. 0: Normal operation. 1: Forces the device into a constant voltage source. In read mode, the ENVM bit is automatically updated to reflect the logic state of the ENVM input pin.																		
<b>MODE_CTRL[1:0]</b>	<b>Mode Control bits.</b> 00: Device in shutdown mode. 01: Device operates in DC light mode. 10: Device operates in DC light and flash mode. 11: Device operates as constant voltage source. To avoid device shutdown by DC light safety timeout, MODE_CTRL[1:0] bits need to be refreshed within less than 11.2s. Writing to REGISTER2[6:5] automatically updates REGISTER1[6:5].																		
<b>FC13[1:0]</b>	<b>Flash Current Control bits (LED1/3).</b> <table style="width: 100%; border: none;"> <tr> <td style="width: 50%;">HC_SEL = 0</td> <td style="width: 50%;">HC_SEL = 1</td> </tr> <tr> <td>00: 275mA</td> <td>00: 665mA</td> </tr> <tr> <td>01: 335mA</td> <td>01: 775mA</td> </tr> <tr> <td>10: 385mA</td> <td>10: 890mA</td> </tr> <tr> <td>11: 445mA</td> <td>11: 1025mA</td> </tr> </table>	HC_SEL = 0	HC_SEL = 1	00: 275mA	00: 665mA	01: 335mA	01: 775mA	10: 385mA	10: 890mA	11: 445mA	11: 1025mA								
HC_SEL = 0	HC_SEL = 1																		
00: 275mA	00: 665mA																		
01: 335mA	01: 775mA																		
10: 385mA	10: 890mA																		
11: 445mA	11: 1025mA																		
<b>FC2[2:0]</b>	<b>Flash Current Control bits (LED2).</b> <table style="width: 100%; border: none;"> <tr> <td style="width: 50%;">HC_SEL = 0</td> <td style="width: 50%;">HC_SEL = 1</td> </tr> <tr> <td>000: 305mA</td> <td>000: 720mA</td> </tr> <tr> <td>001: 335mA</td> <td>001: 775mA</td> </tr> <tr> <td>010: 385mA</td> <td>010: 915mA</td> </tr> <tr> <td>011: 500mA</td> <td>011: 1165mA</td> </tr> <tr> <td>100: 610mA</td> <td>100: 1450mA</td> </tr> <tr> <td>101: 665mA</td> <td>101: 1550mA</td> </tr> <tr> <td>110: 775mA</td> <td>110: 1775mA</td> </tr> <tr> <td>111: 885mA</td> <td>111: 2050mA</td> </tr> </table>	HC_SEL = 0	HC_SEL = 1	000: 305mA	000: 720mA	001: 335mA	001: 775mA	010: 385mA	010: 915mA	011: 500mA	011: 1165mA	100: 610mA	100: 1450mA	101: 665mA	101: 1550mA	110: 775mA	110: 1775mA	111: 885mA	111: 2050mA
HC_SEL = 0	HC_SEL = 1																		
000: 305mA	000: 720mA																		
001: 335mA	001: 775mA																		
010: 385mA	010: 915mA																		
011: 500mA	011: 1165mA																		
100: 610mA	100: 1450mA																		
101: 665mA	101: 1550mA																		
110: 775mA	110: 1775mA																		
111: 885mA	111: 2050mA																		

## REGISTER3 DESCRIPTION

Memory location: 0x03

Description	STIM[2:0]			HPLF	SELSTIM (W) TO (R)	STT	SFT	Tx-MASK
Bits	D7	D6	D5	D4	D3	D2	D1	D0
Memory type	R/W	R/W	R/W	R	R	R/W	R/W	R/W
Default value	1	1	0	0	0	0	0	1

Bit	Description																														
<b>STIM[2:0]</b>	<p><b>Safety Timer bits.</b></p> <table border="1"> <thead> <tr> <th>STIM[2:0]</th> <th>RANGE 0</th> <th>RANGE 1</th> <th>STIM[2:0]</th> <th>RANGE 0</th> <th>RANGE 1</th> </tr> </thead> <tbody> <tr> <td>000</td> <td>68.2ms</td> <td>5.3ms</td> <td>100</td> <td>204.5ms</td> <td>26.6ms</td> </tr> <tr> <td>001</td> <td>102.2ms</td> <td>10.7ms</td> <td>101</td> <td>340.8ms</td> <td>32.0ms</td> </tr> <tr> <td>010</td> <td>136.3ms</td> <td>16.0ms</td> <td>110</td> <td>579.3ms</td> <td>37.3ms</td> </tr> <tr> <td>011</td> <td>170.4ms</td> <td>21.3ms</td> <td>111</td> <td>852ms</td> <td>207.7ms</td> </tr> </tbody> </table>	STIM[2:0]	RANGE 0	RANGE 1	STIM[2:0]	RANGE 0	RANGE 1	000	68.2ms	5.3ms	100	204.5ms	26.6ms	001	102.2ms	10.7ms	101	340.8ms	32.0ms	010	136.3ms	16.0ms	110	579.3ms	37.3ms	011	170.4ms	21.3ms	111	852ms	207.7ms
STIM[2:0]	RANGE 0	RANGE 1	STIM[2:0]	RANGE 0	RANGE 1																										
000	68.2ms	5.3ms	100	204.5ms	26.6ms																										
001	102.2ms	10.7ms	101	340.8ms	32.0ms																										
010	136.3ms	16.0ms	110	579.3ms	37.3ms																										
011	170.4ms	21.3ms	111	852ms	207.7ms																										
<b>HPFL</b>	<p><b>High-Power LED Failure flag.</b>                      0: Proper LED operation.                      1: LED failed (open or shorted).                      High-power LED failure flag is reset after readout</p>																														
<b>SELSTIM</b>	<p><b>Safety Timer Selection Range (Write Only).</b>                      0: Safety timer range 0.                      1: Safety timer range 1.</p>																														
<b>TO</b>	<p><b>Time-Out Flag (Read Only).</b>                      0: No time-out event occurred.                      1: Time-out event occurred. Time-out flag is reset at re-start of the safety timer.</p>																														
<b>STT</b>	<p><b>Safety Timer Trigger bit.</b>                      0: LED safety timer is level sensitive.                      1: LED safety timer is rising edge sensitive.                      This bit is only valid for MODE_CTRL[1:0] = 10.</p>																														
<b>SFT</b>	<p><b>Start/Flash Timer bit.</b>                      In write mode, this bit initiates a flash strobe sequence.                      0: No change in the high-power LED current.                      1: High-power LED current ramps to the flash current level.                      In read mode, this bit indicates the high-power LED status.                      0: High-power LEDs are idle.                      1: Ongoing high-power LED flash strobe.</p>																														
<b>Tx-MASK</b>	<p><b>Flash Blanking Control bit.</b>                      In write mode, this bit enables/disables the flash blanking/LED current reduction function.                      0: Flash blanking disabled.                      1: LED current is reduced to DC light level when Tx-MASK input is high.                      In read mode, this flag indicates whether or not the flashlight masking input has been activated. Tx-MASK flag is reset after readout of the flag.                      0: No flash blanking event occurred.                      1: Tx-MASK input triggered.</p>																														

## REGISTER4 DESCRIPTION

Memory location: 0x04

Description	PG	HOTDIE[1:0]		ILIM	INC[3:0]			
Bits	D7	D6	D5	D4	D3	D2	D1	D0
Memory type	R/W	R	R	R/W	R/W	R/W	R/W	R/W
Default value	0	0	0	0	0	0	0	0

Bit	Description
<b>PG</b>	<p><b>Power Good bit.</b></p> <p>In write mode, this bit selects the functionality of the GPIO/PG output.</p> <p>0: PG signal is routed to the GPIO port.</p> <p>1: GPIO PORT VALUE bit is routed to the GPIO port.</p> <p>In read mode, this bit indicates the output voltage conditions.</p> <p>0: The converter is not operating within the voltage regulation limits.</p> <p>1: The output voltage is within its nominal value.</p>
<b>HOTDIE[1:0]</b>	<p><b>Instantaneous Die Temperature bits.</b></p> <p>00: <math>T_J &lt; +55^\circ\text{C}</math></p> <p>01: <math>+55^\circ\text{C} &lt; T_J &lt; +70^\circ\text{C}</math></p> <p>10: <math>T_J &gt; +70^\circ\text{C}</math></p> <p>11: Thermal shutdown tripped. Indicator flag is reset after readout.</p>
<b>ILIM</b>	<p><b>Inductor Valley Current Limit bit.</b></p> <p>The ILIM bit can only be set before the device enters operation (i.e. initial shutdown state).</p>

CURRENT LIMIT SETTING	ILIM BIT SETTING	HC_SEL INPUT LEVEL	Tx-MASK INPUT LEVEL
1250mA	Low	Low	Low
1750mA	High	Low	Low
1250mA	Low	High	Low
1750mA	High	High	Low
1250mA	Low	Low	High
1750mA	High	Low	High
250mA	Low	High	High
500mA	High	High	High

### INDC[3:0] Indicator Light Control bits.

INDC[3:0]	PRIVACY INDICATOR INDLED CHANNEL	INDC[3:0]	PRIVACY INDICATOR LED1-3 CHANNELS <sup>(1)</sup>
0000	Privacy indicator turned-off	1000	0.8% PWM dimming ratio
0001	INDLED current = 2.6mA	1001	1.6% PWM dimming ratio
0010	INDLED current = 5.2mA	1010	2.3% PWM dimming ratio
0011	INDLED current = 7.9mA	1011	3.1% PWM dimming ratio
0100	Privacy indicator turned-off	1100	3.9% PWM dimming ratio
0101	INDLED current = 2.6mA <sup>(2)</sup>	1101	4.7% PWM dimming ratio
0110	INDLED current = 5.2mA <sup>(2)</sup>	1110	6.3% PWM dimming ratio
0111	INDLED current = 7.9mA <sup>(2)</sup>	1111	8.6% PWM dimming ratio

(1) This mode of operation can only be activated for MODE\_CTRL[1:0] = 01 & ENDCL = 0.

(2) The output node is internally pulled to ground. This mode is only possible for HC\_SEL = L.

## REGISTER5 DESCRIPTION

Memory location: 0x05

Description	SELCAL	ENPSM	DIR (W) STENDCL (R)	GPIO	GPIOYPE	ENLED3	ENLED2	ENLED1
Bits	D7	D6	D5	D4	D3	D2	D1	D0
Memory type	R/W	R/W	R/W	R/W	R/W	R/W	R/W	R/W
Default value	0	1	1	0	1	0	1	0

Bit	Description
<b>SELCAL</b>	<p><b>High-Current LED Forward Voltage Self-Calibration Start bit.</b></p> <p>In write mode, this bit enables/disables the output voltage vs. LED forward voltage/current self-calibration procedure.                      0: Self-calibration disabled.                      1: Self-calibration enabled.</p> <p>In read mode, this bit returns the status of the self-calibration procedure.                      0: Self-calibration ongoing                      1: Self-calibration done Notice that this bit is only being reset at the (re-)start of a calibration cycle.</p>
<b>ENPSM</b>	<p><b>Enable / Disable Power-Save Mode bit.</b></p> <p>0: Power-save mode disabled.                      1: Power-save mode enabled.</p>
<b>STENDCL</b>	<p><b>ENDCL Input Status bit (Read Only).</b></p> <p>This bit indicates the logic state on the ENDCL state. This bit is only active in TPS61300.</p>
<b>DIR</b>	<p><b>GPIO Direction bit.</b></p> <p>0: GPIO configured as input.                      1: GPIO configured as output.</p>
<b>GPIO</b>	<p><b>GPIO Port Value.</b></p> <p>This bit contains the GPIO port value.</p>
<b>GPIOYPE</b>	<p><b>GPIO Port Type.</b></p> <p>0: GPIO is configured as push-pull output.                      1: GPIO is configured as open-drain output.</p>
<b>ENLED3</b>	<p><b>Enable / Disable High-Current LED3 bit.</b></p> <p>0: LED3 input is disabled.                      1: LED3 input is enabled.</p>
<b>ENLED2</b>	<p><b>Enable / Disable High-Current LED2 bit.</b></p> <p>0: LED2 input is disabled.                      1: LED2 input is enabled.</p>
<b>ENLED1</b>	<p><b>Enable / Disable High-Current LED1 bit.</b></p> <p>0: LED1 input is disabled.                      1: LED1 input is enabled.</p>

**REGISTER6 DESCRIPTION (TPS61300, TPS61301)**

Memory location: 0x06

Description	NOT USED			LEDHDR	OV[3:0]			
Bits	D7	D6	D5	D4	D3	D2	D1	D0
Memory type	R/W	R/W	R/W	R	R/W	R/W	R/W	R/W
Default value	0	0	0	0	1	0	0	1

Bit	Description
<b>LEDHDR</b>	<p><b>LED High-Current Regulator Headroom Voltage Monitoring bit.</b></p> <p>This bit returns the headroom voltage status of the LED high-current regulators. This value is being updated at the end of a flash strobe, prior to the LED current ramp-down phase.</p> <p>0: Low headroom voltage. 1: Sufficient headroom voltage.</p>
<b>OV[3:0]</b>	<p>Output Voltage Selection bits. In read mode, these bits return the result of the high-current LED forward voltage self-calibration procedure.</p> <p>In write mode, these bits are used to set the target output voltage (refer to voltage regulation mode). In applications requiring dynamic voltage control, care should be take to set the new target code after voltage mode operation has been enabled (MODE_CTRL[1:0] = 11 and/or ENVM bit = 1).</p>

OV[3:0]	Target Output Voltage
0000	3.825V
0001	3.950V
0010	4.075V
0011	4.200V
0100	4.325V
0101	4.450V
0110	4.575V
0111	4.700V
1000	4.825V
1001	4.950V
1010	5.075V
1011	5.200V
1100	5.325V
1101	5.450V
1110	5.575V
1111	5.700V

## REGISTER6 DESCRIPTION (TPS61305)

Memory location: 0x06

Description	ENTS	LEDHOT	LEDWARN	LEDHDR	OV[3:0]			
Bits	D7	D6	D5	D4	D3	D2	D1	D0
Memory type	R/W	R/W	R	R	R/W	R/W	R/W	R/W
Default value	0	0	0	0	1	0	0	1

Bit	Description
<b>ENTS</b>	<b>Enable / Disable LED Temperature Monitoring.</b> 0: LED temperature monitoring disabled. 1: LED temperature monitoring enabled
<b>LEDHOT</b>	<b>LED Excessive Temperature Flag.</b> This bit can be reset by writing a logic level zero. 0: TS input voltage > 0.345V. 1: TS input voltage < 0.345V.
<b>LEDWARN</b>	<b>LED Temperature Warning Flag (Read Only).</b> This flag is reset after readout. 0: TS input voltage > 1.05V. 1: TS input voltage < 1.05V.
<b>LEDHDR</b>	<b>LED High-Current Regulator Headroom Voltage Monitoring bit.</b> This bit returns the headroom voltage status of the LED high-current regulators. This value is being updated at the end of a flash strobe, prior to the LED current ramp-down phase. 0: Low headroom voltage. 1: Sufficient headroom voltage.
<b>OV[3:0]</b>	<b>Output Voltage Selection bits.</b> In read mode, these bits return the result of the high-current LED forward voltage self-calibration procedure. In write mode, these bits are used to set the target output voltage (refer to voltage regulation mode). In applications requiring dynamic voltage control, care should be take to set the new target code after voltage mode operation has been enabled (MODE_CTRL[1:0] = 11 and/or ENVM bit = 1).

OV[3:0]	Target Output Voltage
0000	3.825V
0001	3.950V
0010	4.075V
0011	4.200V
0100	4.325V
0101	4.450V
0110	4.575V
0111	4.700V
1000	4.825V
1001	4.950V
1010	5.075V
1011	5.200V
1100	5.325V
1101	5.450V
1110	5.575V
1111	5.700V

**REGISTER7 DESCRIPTION**

Memory location: 0x07

Description	NOT USED					REVID[2:0]		
	D7	D6	D5	D4	D3	D2	D1	D0
<b>Bits</b>	D7	D6	D5	D4	D3	D2	D1	D0
<b>Memory type</b>	R/W	R/W	R/W	R/W	R/W	R	R	R
<b>Default value</b>	0	0	0	0	0	1	0	0

Bit	Description
REVID[2:0]	Silicon Revision ID.

## APPLICATION INFORMATION

### INDUCTOR SELECTION

A boost converter requires two main passive components for storing energy during the conversion. A boost inductor and a storage capacitor at the output are required. The TPS6130x device integrates a current limit protection circuitry. The valley current of the PMOS rectifier is sensed to limit the maximum current flowing through the synchronous rectifier and the inductor. The valley peak current limit (250mA/500mA/1250mA/1750mA) is user selectable via the I<sup>2</sup>C interface.

In order to optimize solution size the TPS6130x device has been designed to operate with inductance values between a minimum of 1.3 μH and maximum of 2.9 μH. In typical high current white LED applications a 2.2μH inductance is recommended.

The highest peak current through the inductor and the power switch depends on the output load, the input and output voltages. Estimation of the maximum average inductor current and the maximum inductor peak current can be done using [Equation 2](#) and [Equation 3](#):

$$I_L \approx I_{OUT} \times \frac{V_{OUT}}{\eta \times V_{IN}} \quad (2)$$

$$I_{L(PEAK)} = \frac{V_{IN} \times D}{2 \times f \times L} + \frac{I_{OUT}}{(1-D) \times \eta} \quad \text{with } D = \frac{V_{OUT} - V_{IN}}{V_{OUT}} \quad (3)$$

With

f = switching frequency (2MHz)

L = inductance value (2.2μH)

η = estimated efficiency (85%)

The losses in the inductor caused by magnetic hysteresis losses and copper losses are a major parameter for total circuit efficiency.

**Table 4. List of Inductors**

MANUFACTURER	SERIES	DIMENSIONS	ILIM SETTINGS
FDK	MIPST2520	2.5mm x 2.0mm x 0.8mm max. height	250mA (typ.) 500mA (typ.)
	MIP2520	2.5mm x 2.0mm x 1.0mm max. height	
	MIPSA2520	2.5mm x 2.0mm x 1.2mm max. height	
MURATA	LQM2HP-G0	2.5mm x 2.0mm x 1.0mm max. height	1250mA (typ.)
	LQM2HP-GC	2.5mm x 2.0mm x 1.0mm max. height	
TDK	VL3014AT	2.6mm x 2.8mm x 1.4mm max. height	1750mA (typ.)
COILCRAFT	LPS3015	3.0mm x 3.0mm x 1.5mm max. height	
MURATA	LQH2HPN	2.5mm x 2.0mm x 1.2mm max. height	1750mA (typ.)
TOKO	FDSE0312	3.0mm x 3.0mm x 1.2mm max. height	
MURATA	LQM32PN	3.2mm x 2.5mm x 1.2mm max. height	

### INPUT CAPACITOR

For good input voltage filtering low ESR ceramic capacitors are recommended. A 10-μF input capacitor is recommended to improve transient behavior of the regulator and EMI behavior of the total power supply circuit. The input capacitor should be placed as close as possible to the input pin of the converter.



## OUTPUT CAPACITOR

The major parameter necessary to define the output capacitor is the maximum allowed output voltage ripple of the converter. This ripple is determined by two parameters of the capacitor, the capacitance and the ESR. It is possible to calculate the minimum capacitance needed for the defined ripple, supposing that the ESR is zero, by using [Equation 4](#):

$$C_{\min} \approx \frac{I_{\text{OUT}} \times (V_{\text{OUT}} - V_{\text{IN}})}{f \times \Delta V \times V_{\text{OUT}}} \quad (4)$$

Parameter  $f$  is the switching frequency and  $\Delta V$  is the maximum allowed ripple.

With a chosen ripple voltage of 10mV, a minimum capacitance of 10 $\mu$ F is needed. The total ripple is larger due to the ESR of the output capacitor. This additional component of the ripple can be calculated using [Equation 5](#):

$$\Delta V_{\text{ESR}} = I_{\text{OUT}} \times R_{\text{ESR}} \quad (5)$$

The total ripple is the sum of the ripple caused by the capacitance and the ripple caused by the ESR of the capacitor. Additional ripple is caused by load transients. This means that the output capacitor has to completely supply the load during the charging phase of the inductor. A reasonable value of the output capacitance depends on the speed of the load transients and the load current during the load change.

For the standard current white LED application ( $\text{HC\_SEL} = 0$ , TPS6130x), a minimum of 3 $\mu$ F effective output capacitance is usually required when operating with 2.2 $\mu$ H (typ) inductors. For solution size reasons, this is usually one or more X5R/X7R ceramic capacitors.

Depending on the material, size and therefore margin to the rated voltage of the used output capacitor, degradation on the effective capacitance can be observed. This loss of capacitance is related to the DC bias voltage applied. It is therefore always recommended to check that the selected capacitors are showing enough effective capacitance under real operating conditions.

To support high-current camera flash application ( $\text{HC\_SEL} = 1$ ), the converter is designed to work with a low voltage super-capacitor on the output to take advantage of the benefits they offer. A low-voltage super-capacitor in the 0.1F to 1.5F range, and with ESR larger than 40m $\Omega$ , is suitable in the TPS6130x application circuit. For this device the output capacitor should be connected between the VOUT pin and a good ground connection.

### NTC SELECTION (TPS61305, TPS61306)

The TPS61305/306 requires a negative thermistor (NTC) for sensing the LED temperature. Once the temperature monitoring feature is activated, a regulated bias current (c.a. 24µA) will be driven out of the TS port and produce a voltage across the thermistor.

If the temperature of the NTC-thermistor rises due to the heat dissipated by the LED, the voltage on the TS input pin decreases. When this voltage goes below the “warning threshold”, the LEDWARN bit in REGISTER6 is set. This flag is cleared by reading the register.

If the voltage on the TS input decreases further and falls below “hot threshold”, the LEDHOT bit in REGISTER6 is set and the device goes automatically in shutdown mode to avoid damaging the LED. This status is latched until the LEDHOT flag gets cleared by software.

The selection of the NTC-thermistor value strongly depends on the power dissipated by the LED and all components surrounding the temperature sensor and on the cooling capabilities of each specific application. With a 220kΩ (at 25°C) thermistor, the valid temperature window is set between 60°C to 90°C. The temperature window can be enlarged by adding external resistors to the TS pin application circuit. In order to ensure proper triggering of the LEDWARN and LEDHOT flags in noisy environments, the TS signal may require additional filtering capacitance.

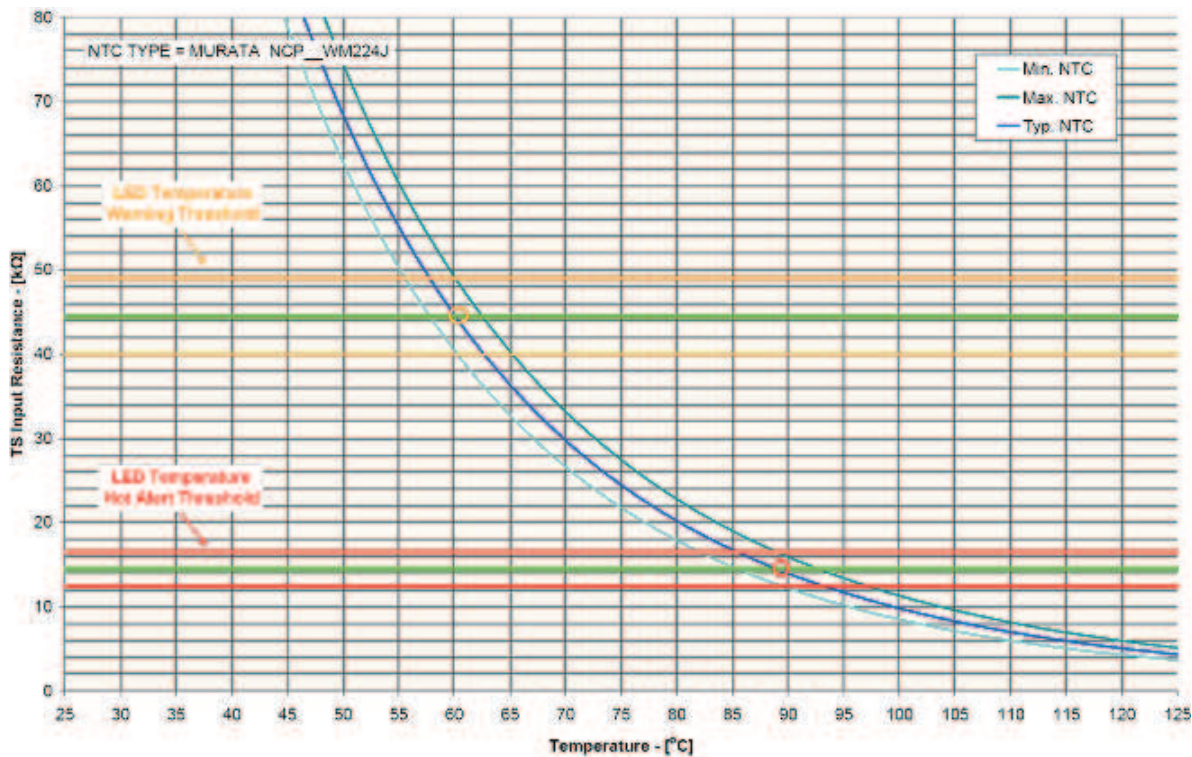

Figure 83. Temperature Monitoring Characteristic

Table 5. List of Negative Thermistor (NTC)

MANUFACTURER	PART NUMBER	VALUE
MURATA	NCP18WM224J03RB	220kΩ

## CHECKING LOOP STABILITY

The first step of circuit and stability evaluation is to look from a steady-state perspective at the following signals:

- Switching node, SW
- Inductor current,  $I_L$
- Output ripple voltage,  $V_{OUT(AC)}$

These are the basic signals that need to be measured when evaluating a switching converter. When the switching waveform shows large duty cycle jitter or the output voltage or inductor current shows oscillations the regulation loop may be unstable. This is often a result of improper board layout and/or L-C combination.

As a next step in the evaluation of the regulation loop the load transient response needs to be tested. VOUT can be monitored for settling time, overshoot or ringing that helps judge the converter's stability. Without any ringing, the loop has usually more than 45° of phase margin.

Because the damping factor of the circuitry is directly related to several resistive parameters (e.g., MOSFET  $r_{DS(on)}$ ) that are temperature dependant, the loop stability analysis has to be done over the input voltage range, output current range, and temperature range.

## LAYOUT CONSIDERATIONS

As for all switching power supplies, the layout is an important step in the design, especially at high peak currents and high switching frequencies. If the layout is not carefully done, the regulator could show stability problems as well as EMI problems. Therefore, use wide and short traces for the main current path and for the power ground tracks.

The input capacitor, output capacitor, and the inductor should be placed as close as possible to the IC. Use a common ground node for power ground and a different one for control ground to minimize the effects of ground noise. Connect these ground nodes at any place close to one of the ground pins of the IC.

To lay out the control ground, it is recommended to use short traces as well, separated from the power ground traces. This avoids ground shift problems, which can occur due to superimposition of power ground current and control ground current.

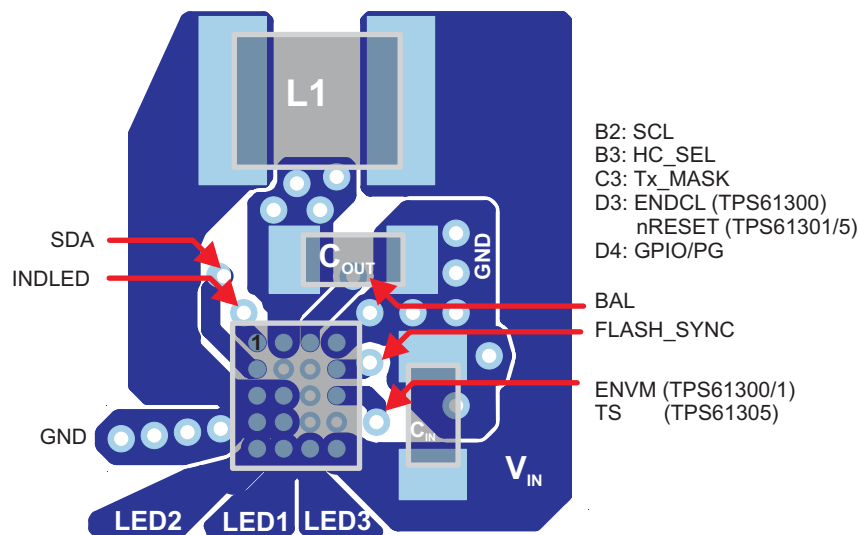

Figure 84. Suggested Layout (Top)

### THERMAL INFORMATION

Implementation of integrated circuits in low-profile and fine-pitch surface-mount packages typically requires special attention to power dissipation. Many system-dependant issues such as thermal coupling, airflow, added heat sinks and convection surfaces, and the presence of other heat-generating components affect the power-dissipation limits of a given component.

Three basic approaches for enhancing thermal performance are listed below:

- Improving the power dissipation capability of the PCB design
- Improving the thermal coupling of the component to the PCB
- Introducing airflow in the system

Junction-to-ambient thermal resistance is highly application and board-layout dependent. In applications where high maximum power dissipation exists, special care must be paid to thermal dissipation issues in board design. The maximum junction temperature ( $T_J$ ) of the TPS6130x is 150°C.

The maximum power dissipation is especially critical when the device operates in the linear down mode at high LED current. For single pulse power thermal analysis (e.g., flashlight strobe), the allowable power dissipation for the device is given by [Figure 85](#). These values are derived using the reference design.

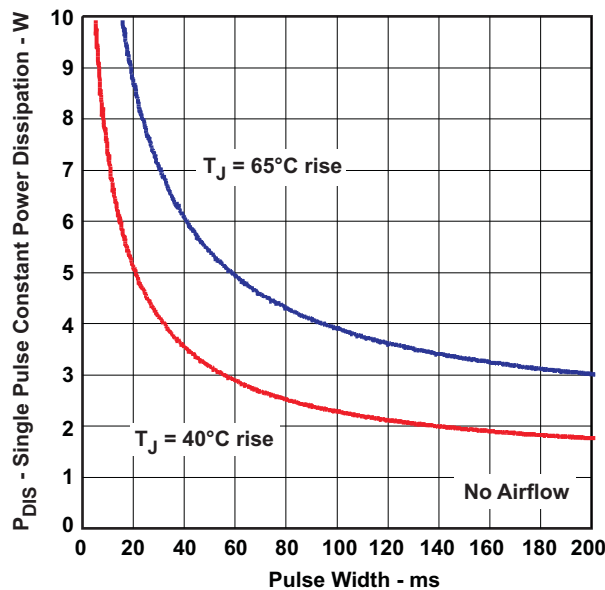

Figure 85. Single Pulse Power Capability

TYPICAL APPLICATIONS

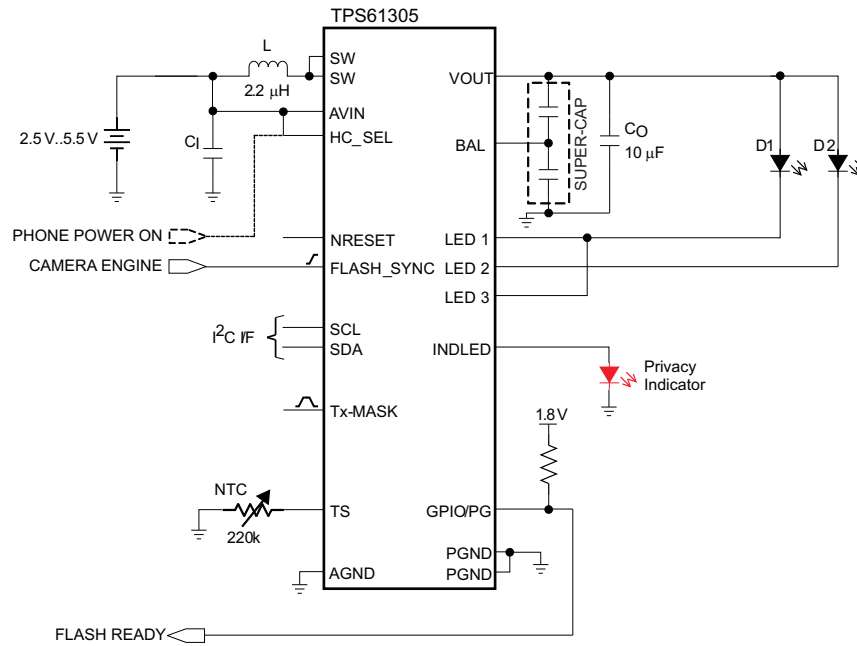

Figure 86. 4100mA Two White High-Power LED Flashlight Featuring Storage Capacitor

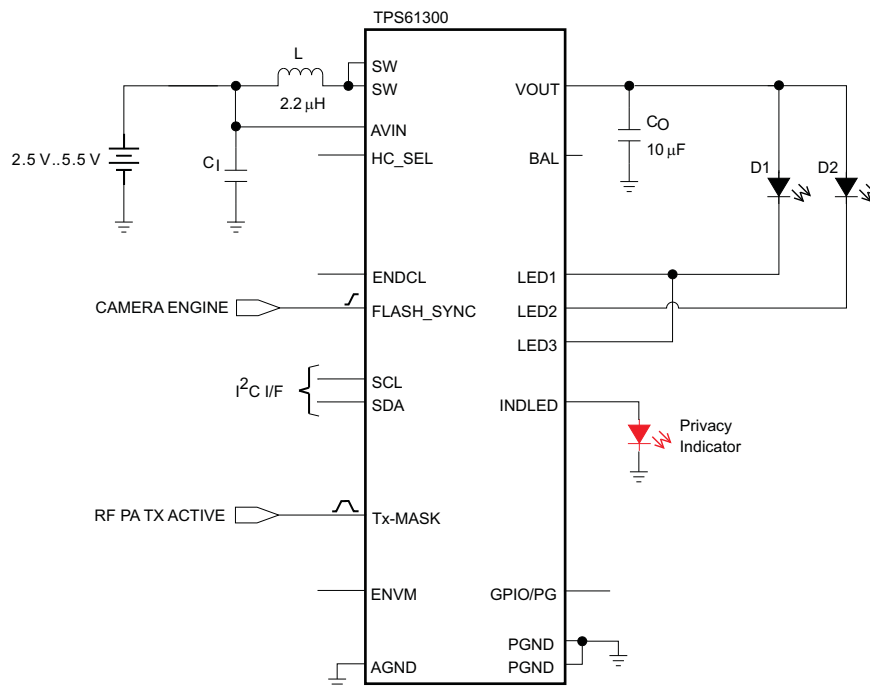

Figure 87. 2x 600mA High Power White LED Solution Featuring Privacy Indicator

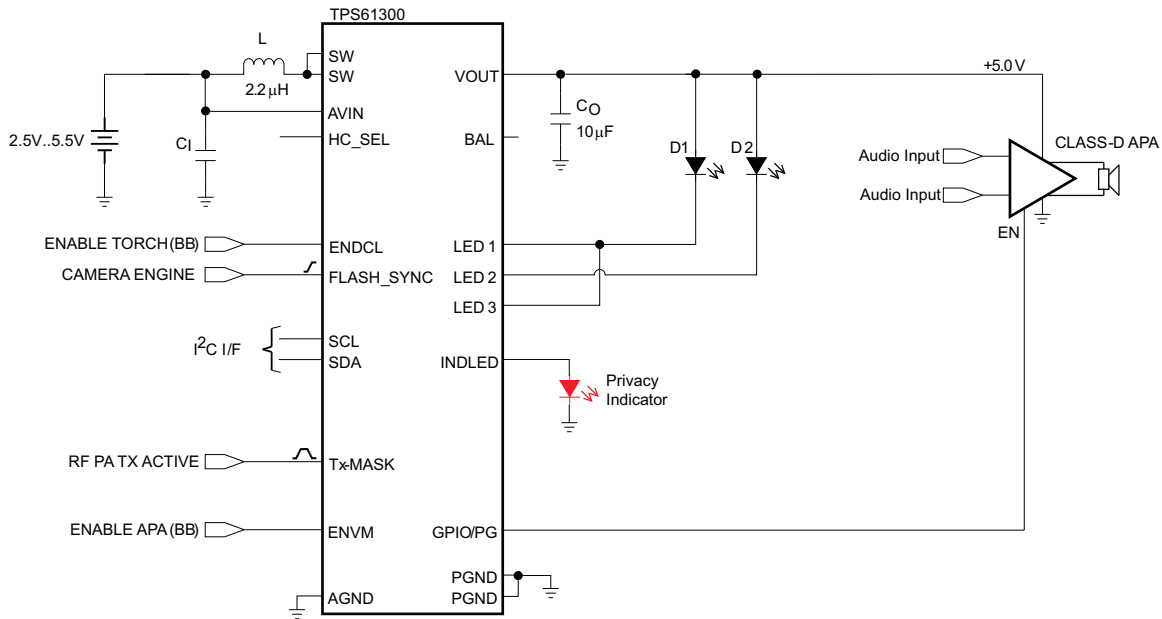

Figure 88. White LED Flashlight Driver and Audio Amplifier Power Supply Operating Simultaneously

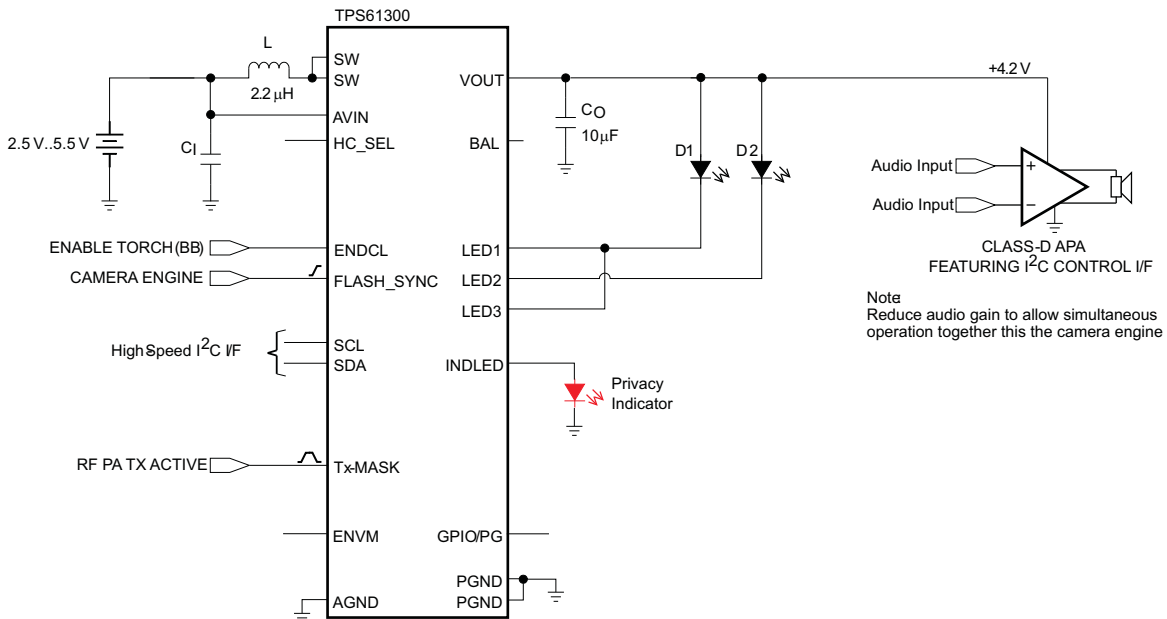

Figure 89. White LED Flashlight Driver and Audio Amplifier Power Supply Operating Simultaneously

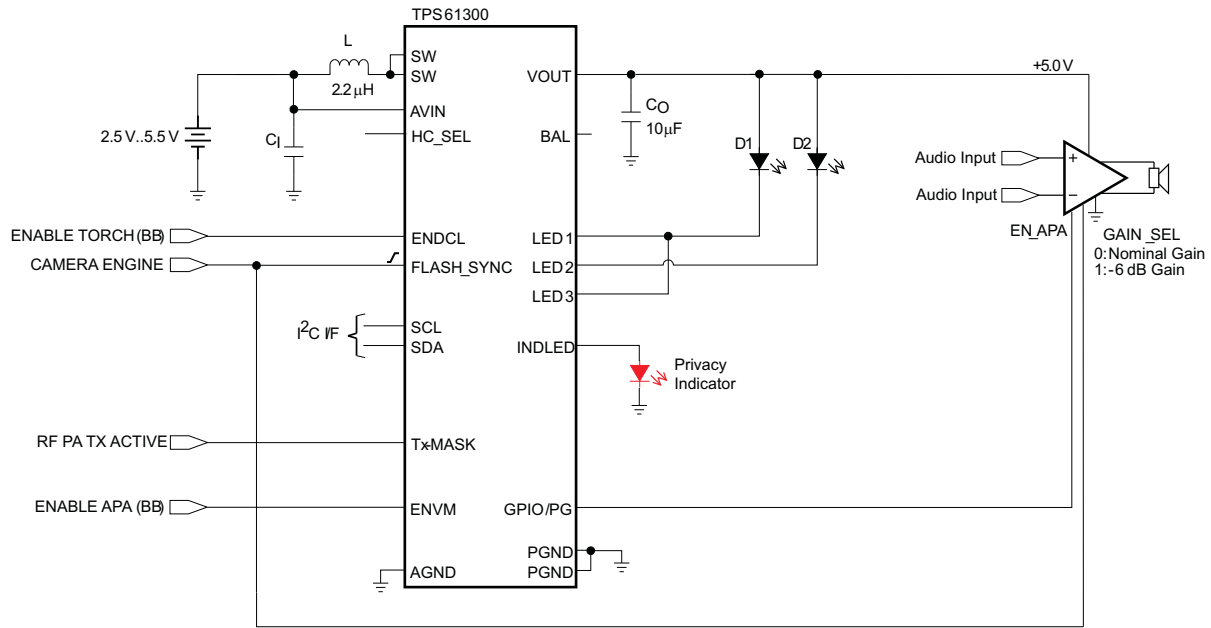

Figure 90. White LED Flashlight Driver and Audio Amplifier Power Supply Exclusive Operation

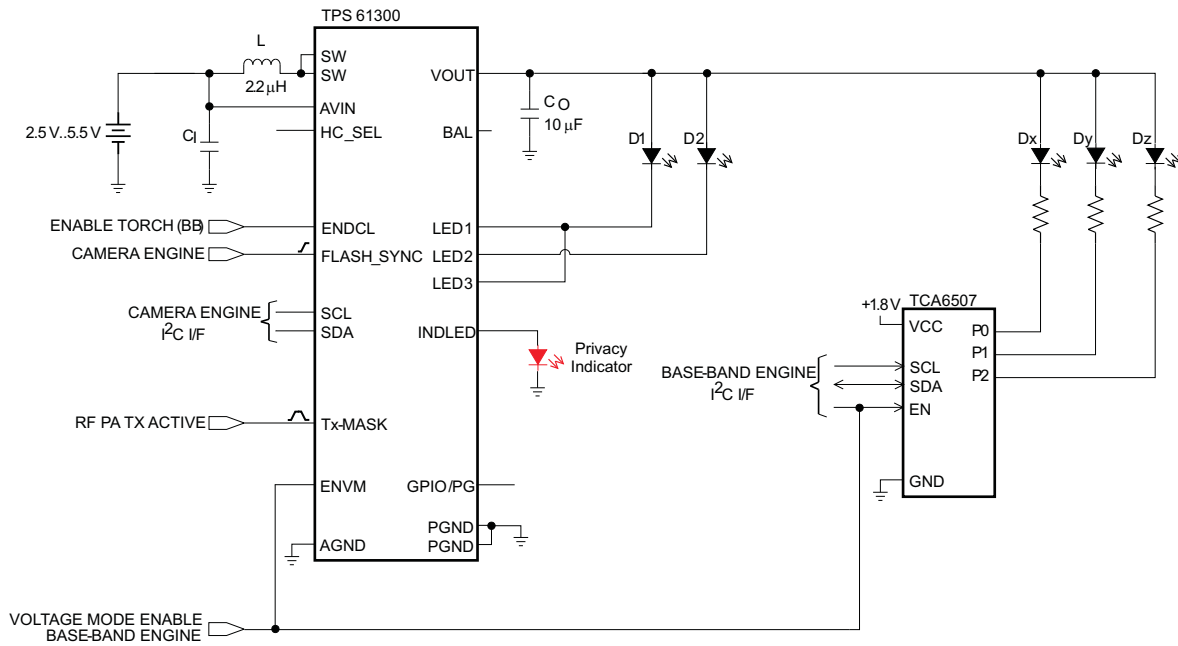
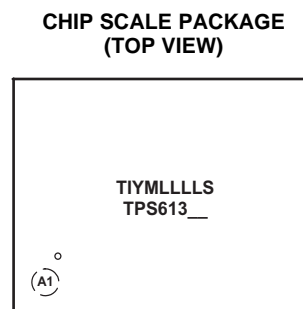
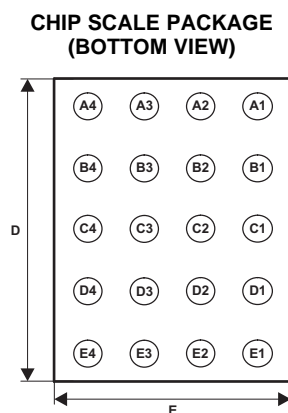

Figure 91. White LED Flashlight Driver and Auxiliary Lighting Zone Power Supply

## PACKAGE SUMMARY



Code:

- YM — Year Month date code
- LLLL — Lot trace code
- S — Assembly site code

## CHIP SCALE PACKAGE DIMENSIONS

The TPS6130x device is available in a 20-bump chip scale package (YFF, NanoFree™). The package dimensions are given as:

- D = 2170 ±30 μm
- E = 1928 ±30 μm



NOTE: Page numbers of current version may differ from previous versions.

<b>Changes from Original (June 2009) to Revision A</b>	<b>Page</b>
• Deleted product preview device number TPS61306 from data sheet header. ....	1
• Deleted "Product Preview" cross reference from TPS61301 device in Available Options table. ....	2
• Added "TI" to package marking illustration example .....	72

<b>Changes from Revision A (September 2010) to Revision B</b>	<b>Page</b>
• Changed $I_{STBY}$ MAX current from 5 $\mu$ A to 12 $\mu$ A .....	3

**TAPE AND REEL INFORMATION**
**REEL DIMENSIONS**

**TAPE DIMENSIONS**

A0	Dimension designed to accommodate the component width
B0	Dimension designed to accommodate the component length
K0	Dimension designed to accommodate the component thickness
W	Overall width of the carrier tape
P1	Pitch between successive cavity centers

**TAPE AND REEL INFORMATION**

\*All dimensions are nominal

Device	Package Type	Package Drawing	Pins	SPQ	Reel Diameter (mm)	Reel Width W1 (mm)	A0 (mm)	B0 (mm)	K0 (mm)	P1 (mm)	W (mm)	Pin1 Quadrant
TPS61300YFFR	DSBGA	YFF	20	3000	180.0	8.4	2.2	2.35	0.8	4.0	8.0	Q1
TPS61300YFFT	DSBGA	YFF	20	250	180.0	8.4	2.2	2.35	0.8	4.0	8.0	Q1
TPS61301YFFR	DSBGA	YFF	20	3000	180.0	8.4	2.18	2.18	0.81	4.0	8.0	Q1
TPS61301YFFT	DSBGA	YFF	20	250	180.0	8.4	2.18	2.18	0.81	4.0	8.0	Q1
TPS61305YFFR	DSBGA	YFF	20	3000	180.0	8.4	2.18	2.18	0.81	4.0	8.0	Q1
TPS61305YFFT	DSBGA	YFF	20	250	180.0	8.4	2.18	2.18	0.81	4.0	8.0	Q1

**TAPE AND REEL BOX DIMENSIONS**

\*All dimensions are nominal

Device	Package Type	Package Drawing	Pins	SPQ	Length (mm)	Width (mm)	Height (mm)
TPS61300YFFR	DSBGA	YFF	20	3000	210.0	185.0	35.0
TPS61300YFFT	DSBGA	YFF	20	250	210.0	185.0	35.0
TPS61301YFFR	DSBGA	YFF	20	3000	210.0	185.0	35.0
TPS61301YFFT	DSBGA	YFF	20	250	210.0	185.0	35.0
TPS61305YFFR	DSBGA	YFF	20	3000	210.0	185.0	35.0
TPS61305YFFT	DSBGA	YFF	20	250	210.0	185.0	35.0

YFF (R-XBGA-N20)

DIE-SIZE BALL GRID ARRAY

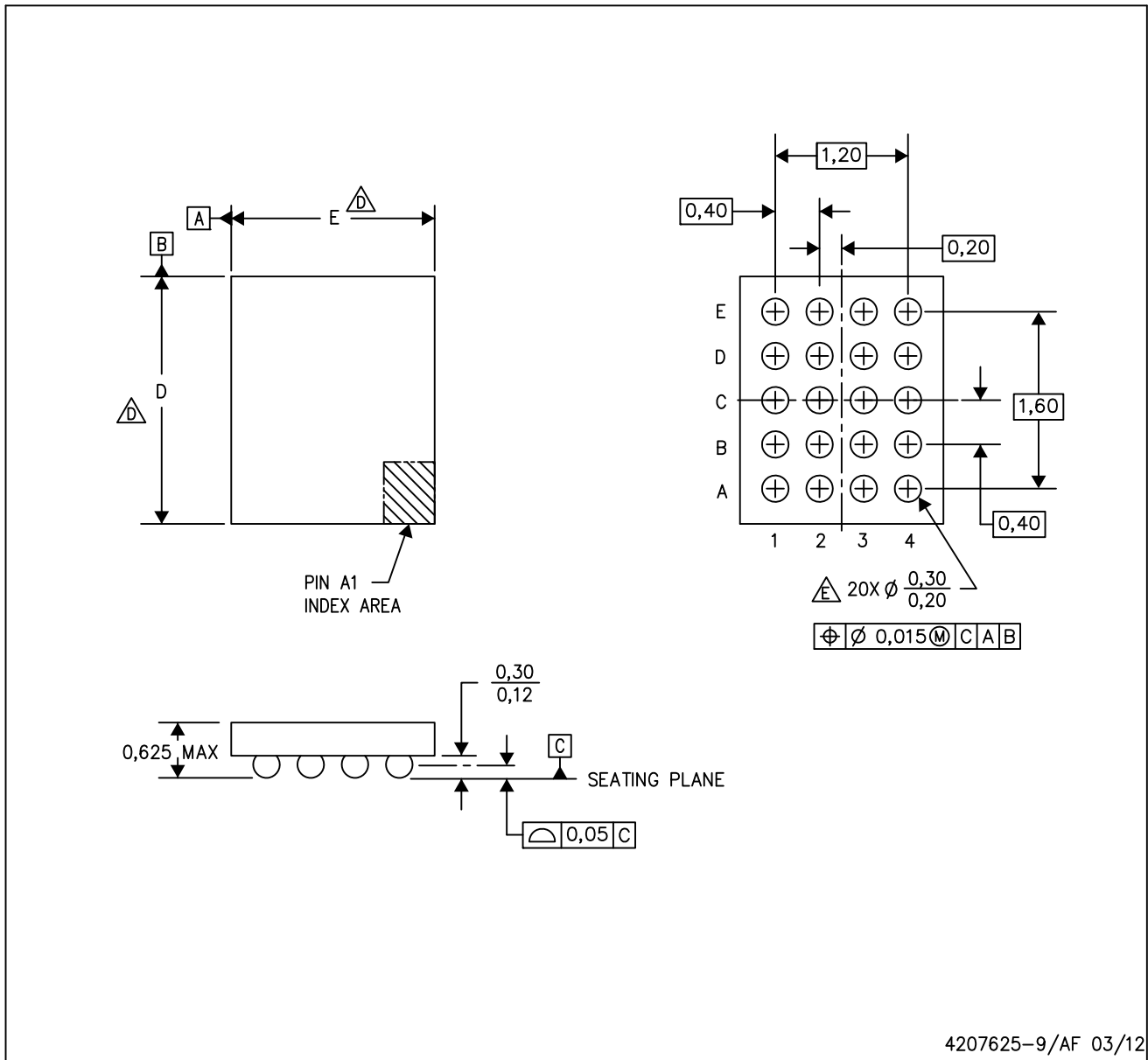

4207625-9/AF 03/12

- NOTES:
- A. All linear dimensions are in millimeters. Dimensioning and tolerancing per ASME Y14.5M-1994.
  - B. This drawing is subject to change without notice.
  - C. NanoFree™ package configuration.
  - $\triangle$  The package size (Dimension D and E) of a particular device is specified in the device Product Data Sheet version of this drawing, in case it cannot be found in the product data sheet please contact a local TI representative.
  - E. Reference Product Data Sheet for array population.  
5 x 4 matrix pattern is shown for illustration only.
  - F. This package contains Pb-free balls.

NanoFree is a trademark of Texas Instruments

## IMPORTANT NOTICE

Texas Instruments Incorporated and its subsidiaries (TI) reserve the right to make corrections, modifications, enhancements, improvements, and other changes to its products and services at any time and to discontinue any product or service without notice. Customers should obtain the latest relevant information before placing orders and should verify that such information is current and complete. All products are sold subject to TI's terms and conditions of sale supplied at the time of order acknowledgment.

TI warrants performance of its hardware products to the specifications applicable at the time of sale in accordance with TI's standard warranty. Testing and other quality control techniques are used to the extent TI deems necessary to support this warranty. Except where mandated by government requirements, testing of all parameters of each product is not necessarily performed.

TI assumes no liability for applications assistance or customer product design. Customers are responsible for their products and applications using TI components. To minimize the risks associated with customer products and applications, customers should provide adequate design and operating safeguards.

TI does not warrant or represent that any license, either express or implied, is granted under any TI patent right, copyright, mask work right, or other TI intellectual property right relating to any combination, machine, or process in which TI products or services are used. Information published by TI regarding third-party products or services does not constitute a license from TI to use such products or services or a warranty or endorsement thereof. Use of such information may require a license from a third party under the patents or other intellectual property of the third party, or a license from TI under the patents or other intellectual property of TI.

Reproduction of TI information in TI data books or data sheets is permissible only if reproduction is without alteration and is accompanied by all associated warranties, conditions, limitations, and notices. Reproduction of this information with alteration is an unfair and deceptive business practice. TI is not responsible or liable for such altered documentation. Information of third parties may be subject to additional restrictions.

Resale of TI products or services with statements different from or beyond the parameters stated by TI for that product or service voids all express and any implied warranties for the associated TI product or service and is an unfair and deceptive business practice. TI is not responsible or liable for any such statements.

TI products are not authorized for use in safety-critical applications (such as life support) where a failure of the TI product would reasonably be expected to cause severe personal injury or death, unless officers of the parties have executed an agreement specifically governing such use. Buyers represent that they have all necessary expertise in the safety and regulatory ramifications of their applications, and acknowledge and agree that they are solely responsible for all legal, regulatory and safety-related requirements concerning their products and any use of TI products in such safety-critical applications, notwithstanding any applications-related information or support that may be provided by TI. Further, Buyers must fully indemnify TI and its representatives against any damages arising out of the use of TI products in such safety-critical applications.

TI products are neither designed nor intended for use in military/aerospace applications or environments unless the TI products are specifically designated by TI as military-grade or "enhanced plastic." Only products designated by TI as military-grade meet military specifications. Buyers acknowledge and agree that any such use of TI products which TI has not designated as military-grade is solely at the Buyer's risk, and that they are solely responsible for compliance with all legal and regulatory requirements in connection with such use.

TI products are neither designed nor intended for use in automotive applications or environments unless the specific TI products are designated by TI as compliant with ISO/TS 16949 requirements. Buyers acknowledge and agree that, if they use any non-designated products in automotive applications, TI will not be responsible for any failure to meet such requirements.

Following are URLs where you can obtain information on other Texas Instruments products and application solutions:

### Products

Audio	<a href="http://www.ti.com/audio">www.ti.com/audio</a>
Amplifiers	<a href="http://amplifier.ti.com">amplifier.ti.com</a>
Data Converters	<a href="http://dataconverter.ti.com">dataconverter.ti.com</a>
DLP® Products	<a href="http://www.dlp.com">www.dlp.com</a>
DSP	<a href="http://dsp.ti.com">dsp.ti.com</a>
Clocks and Timers	<a href="http://www.ti.com/clocks">www.ti.com/clocks</a>
Interface	<a href="http://interface.ti.com">interface.ti.com</a>
Logic	<a href="http://logic.ti.com">logic.ti.com</a>
Power Mgmt	<a href="http://power.ti.com">power.ti.com</a>
Microcontrollers	<a href="http://microcontroller.ti.com">microcontroller.ti.com</a>
RFID	<a href="http://www.ti-rfid.com">www.ti-rfid.com</a>
OMAP Mobile Processors	<a href="http://www.ti.com/omap">www.ti.com/omap</a>
Wireless Connectivity	<a href="http://www.ti.com/wirelessconnectivity">www.ti.com/wirelessconnectivity</a>

### Applications

Automotive and Transportation	<a href="http://www.ti.com/automotive">www.ti.com/automotive</a>
Communications and Telecom	<a href="http://www.ti.com/communications">www.ti.com/communications</a>
Computers and Peripherals	<a href="http://www.ti.com/computers">www.ti.com/computers</a>
Consumer Electronics	<a href="http://www.ti.com/consumer-apps">www.ti.com/consumer-apps</a>
Energy and Lighting	<a href="http://www.ti.com/energy">www.ti.com/energy</a>
Industrial	<a href="http://www.ti.com/industrial">www.ti.com/industrial</a>
Medical	<a href="http://www.ti.com/medical">www.ti.com/medical</a>
Security	<a href="http://www.ti.com/security">www.ti.com/security</a>
Space, Avionics and Defense	<a href="http://www.ti.com/space-avionics-defense">www.ti.com/space-avionics-defense</a>
Video and Imaging	<a href="http://www.ti.com/video">www.ti.com/video</a>

TI E2E Community Home Page

[e2e.ti.com](http://e2e.ti.com)

Mailing Address: Texas Instruments, Post Office Box 655303, Dallas, Texas 75265  
Copyright © 2012, Texas Instruments Incorporated