

# IS31LT3505

## 1.0MHZ BOOST CONVERTER WITH 35V INTERNAL NMOS

OCTOBER 2011

### DESCRIPTION

The IS31LT3505 is a constant current step-up converter with internal NMOS. The step-up converter topology allows series connection of the white LEDs so the LED currents are identical for uniform brightness as well as constant output voltage to drive other devices. The output current of each channel can be set by an external resistor and dimming the brightness of LEDs with the PWM signal or DC voltage. The IS31LT3505 operates with a switching frequency up to 1 MHz. A low 0.3V feedback voltage minimizes power loss in the current setting resistor for better efficiency. With OVP circuit, the chip and the system can be safe even if the load is not connected.

IS31LT3505 is available in MSOP-10. It operates from 6V to 30V over the temperature range of -40°C to +85°C.

### FEATURES

- 6V to 30V supply voltage
- High efficiency: 90 % typical
- PWM dimming control
- Fast 1.0MHz switching frequency
- Internal high power 35V NMOS
- Internal soft start
- Adjustable LED Open Protection
- Over-temperature protection
- MSOP-10

### APPLICATIONS

- TV monitor backlighting
- PDA, handheld computer
- GPS receiver

### TYPICAL APPLICATION CIRCUIT

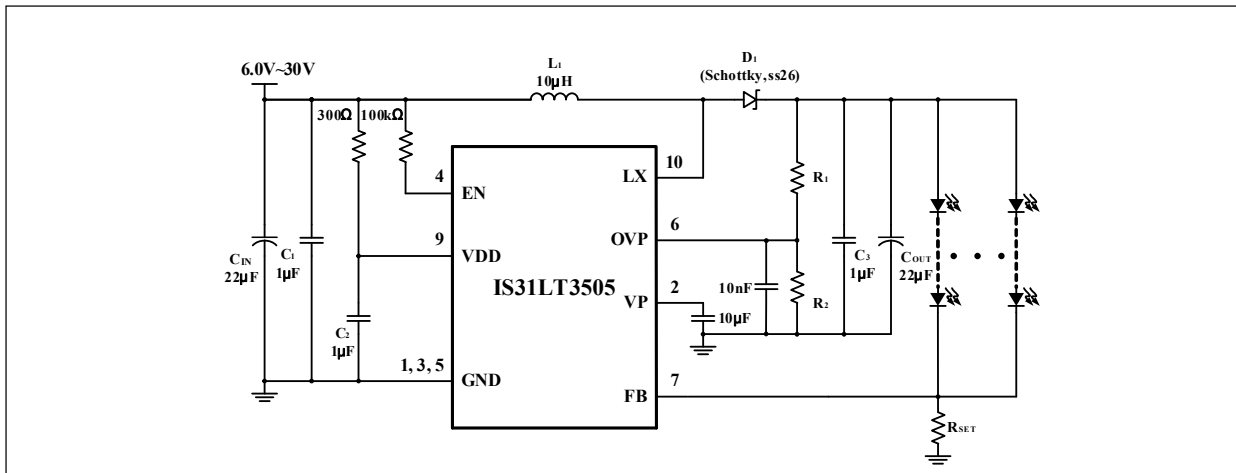

Figure 1 Application Circuit (Constant Current to Drive White LEDs)

Copyright © 2011 Integrated Silicon Solution, Inc. All rights reserved. ISSI reserves the right to make changes to this specification and its products at any time without notice. ISSI assumes no liability arising out of the application or use of any information, products or services described herein. Customers are advised to obtain the latest version of this device specification before relying on any published information and before placing orders for products. Integrated Silicon Solution, Inc. does not recommend the use of any of its products in life support applications where the failure or malfunction of the product can reasonably be expected to cause failure of the life support system or to significantly affect its safety or effectiveness. Products are not authorized for use in such applications unless Integrated Silicon Solution, Inc. receives written assurance to its satisfaction, that:

- a.) the risk of injury or damage has been minimized;
- b.) the user assume all such risks; and
- c.) potential liability of Integrated Silicon Solution, Inc is adequately protected under the circumstances

# IS31LT3505

## PIN CONFIGURATION

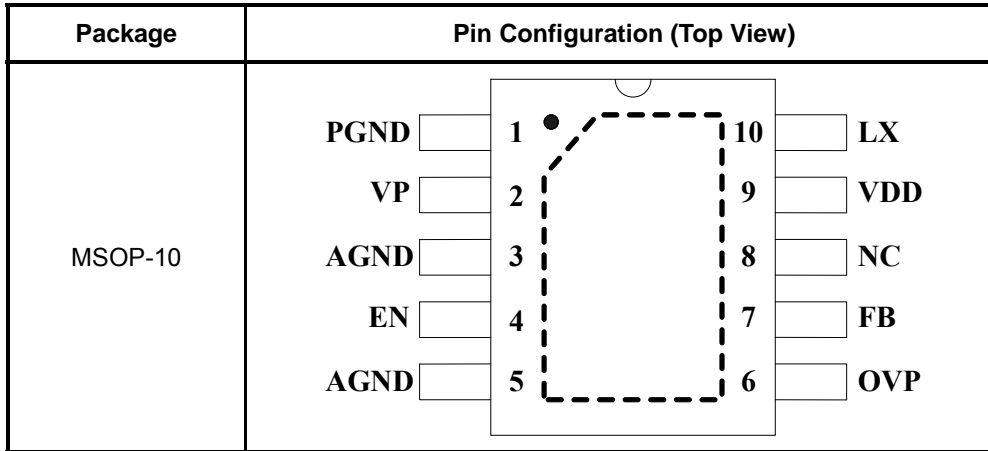

## PIN DESCRIPTION

Pin	Name	I/O	Description
1	PGND	-	Power ground.
3,5	GND	-	Ground.
2	VP	I/O	Internal 5V regulator. A power supply for the internal NMOS gate driver and the internal control circuitry.
4	EN	I	Enable control input. Do not let this pin floating.
6	OVP	I	Over-voltage protection of output.
7	FB	I	Feedback voltage of output.
8	NC	-	No connection, must floating.
9	VDD	-	Supply voltage.
10	LX	O	The drain of the internal NMOS.
	Thermal Pad	-	Connect to Ground.

## ORDERING INFORMATION

### INDUSTRIAL RANGE: -40°C TO +85°C

Order Part No.	Package	QTY/Reel
IS31LT3505-SLS2-TR	MSOP-10, Lead-free	2500

**ABSOLUTE MAXIMUM RATINGS**

Parameter	Value
Supply voltage, $V_{DD}$	-0.3V ~ +6.0V
Voltage at LX pin	-0.3V ~ +40V
All other pins	-0.3V ~ +6.0V
Operate temperature range	-40°C ~ +85°C
Storage temperature range	-65°C ~ +150°C
Junction temperature range	-40°C ~ +150°C
Lead temperature (Soldering, 10s)	260°C
$R_{\theta JA}$	60°C/W
ESD HBM	4kV

Stresses beyond those listed under "Absolute Maximum Ratings" may cause permanent damage to the device. These are stress ratings only and functional operation of the device at these or any other condition beyond those indicated in the operational sections of the specifications is not implied. Exposure to absolute maximum rating conditions for extended periods may affect device reliability.

**ELECTRICAL CHARACTERISTICS**

$T_A = -40^\circ\text{C} \sim +85^\circ\text{C}$ ,  $V_{DD} = 12\text{V}$  (unless otherwise noted), Typical values are at  $T_A = 25^\circ\text{C}$ .

Symbol	Parameter	Condition	Min.	Typ.	Max.	Unit
$V_{DD}$	Supply voltage		6		30	V
UVLO	Undervoltage threshold	VP falling		2.9		V
$\Delta\text{UVLO}$	Undervoltage threshold hysteresis			100		mV
$I_{DD}$	Supply current	Continuous switching		2		mA
		No switching		1.1		
$I_{SD}$	Shutdown current	$V_{EN} = 0\text{V}$		15		$\mu\text{A}$
VP	Internal regulator	$6\text{V} < V_{DD} < 30\text{V}$ , $C_{VP} = 10\mu\text{F}$	4.5	5	5.5	V
$V_{EN\ ON}$	EN on threshold	$V_{EN}$ rising	1.4			V
$V_{EN\ OFF}$	EN off threshold	$V_{EN}$ falling			0.4	V
Fosc	Operation frequency			1		MHz
$D_{MAX}$	Maximum duty cycle			90		%
$R_{DS\_ON}$	Internal NMOS on-resistance			0.8	1.2	$\Omega$
$I_{SW\_LK}$	Internal NMOS leakage current	$V_{SW} = 35\text{V}$			1	$\mu\text{A}$
$I_{SW\_LIMIT}$	Internal NMOS current limit	Duty = 90%	1.8	2.1	2.4	A
$V_{OVP\_TH}$	Over voltage threshold			0.9		V
$V_{FB}$	Feedback voltage		0.285	0.3	0.315	V
$T_{OTP}$	Over temperature threshold			150		$^\circ\text{C}$
$T_{OTP\_HYS}$	Over temperature threshold hysteresis			50		$^\circ\text{C}$

## TYPICAL OPERATING CHARACTERISTICS

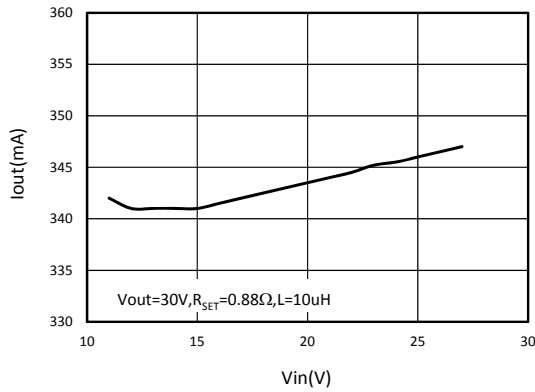

Figure 2 Iout vs. Vin

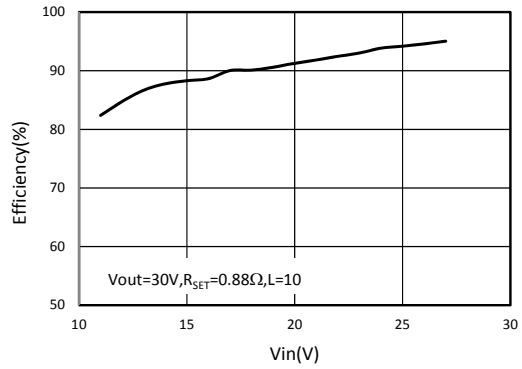

Figure 3 Efficiency vs. Vin

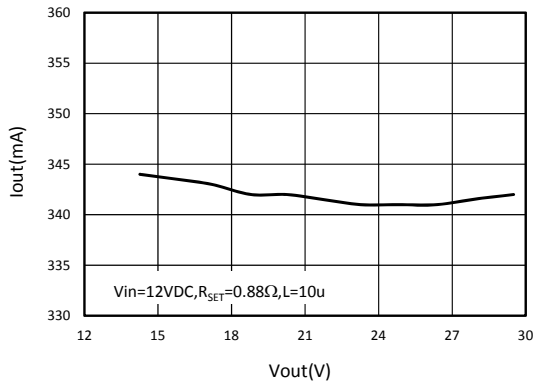

Figure 4 Iout vs. Vout

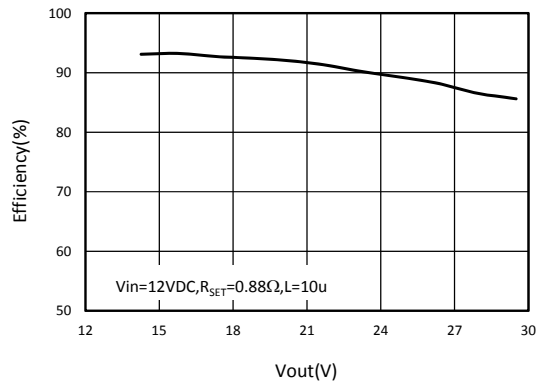

Figure 5 Efficiency vs. Vout

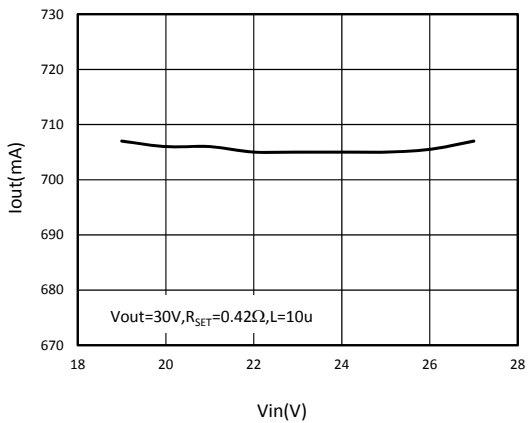

Figure 6 Iout vs. Vin

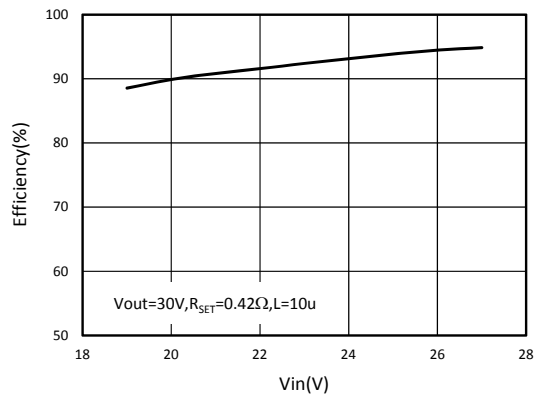

Figure 7 Efficiency vs. Vin

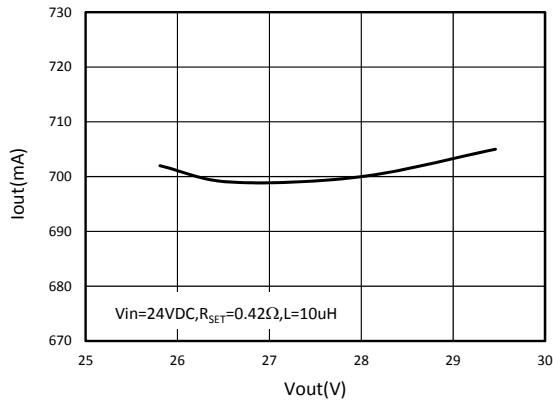

Figure 8 Iout vs. Vout

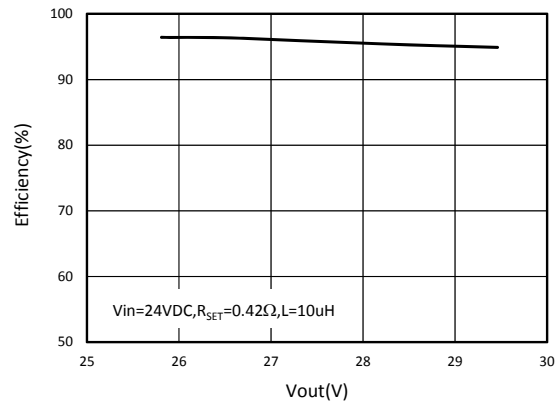

Figure 9 Efficiency vs. Vout

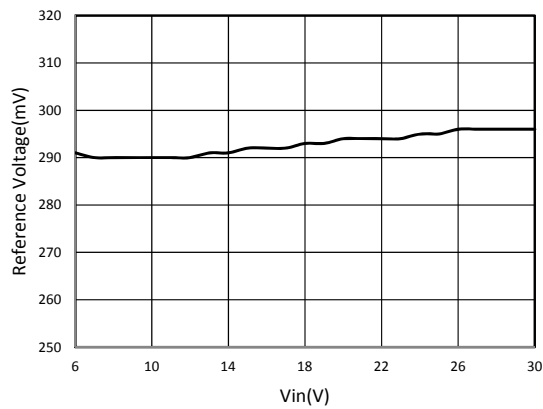

Figure 10 V<sub>FB</sub> voltage vs. Vin

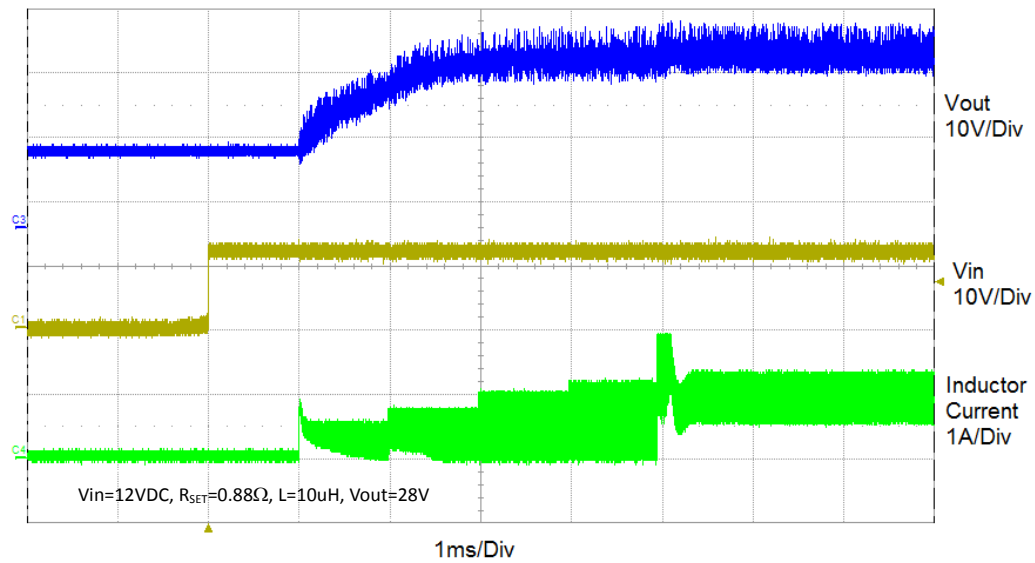

Figure 11 Soft-start waveform

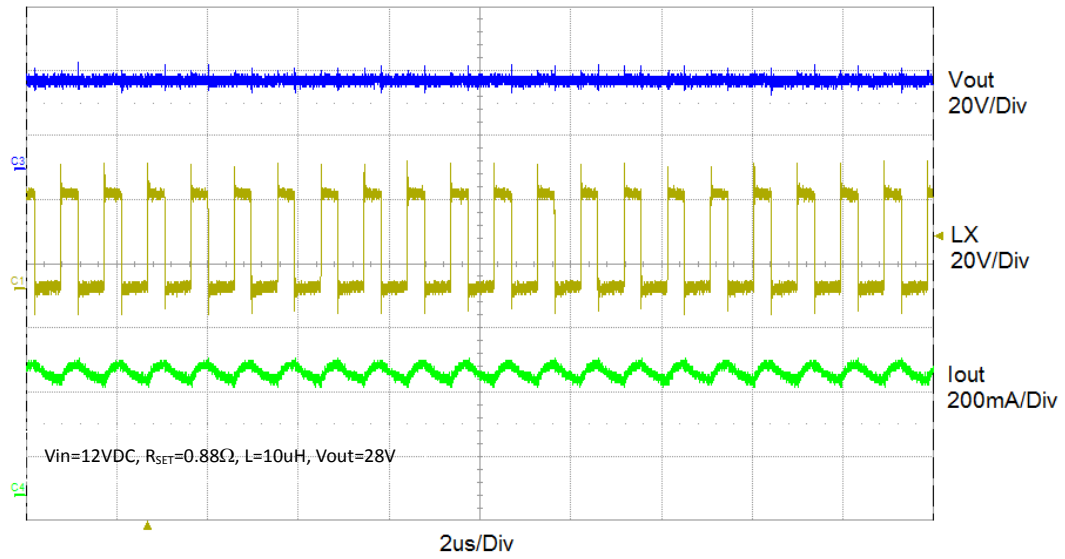

Figure 12 Operation waveform

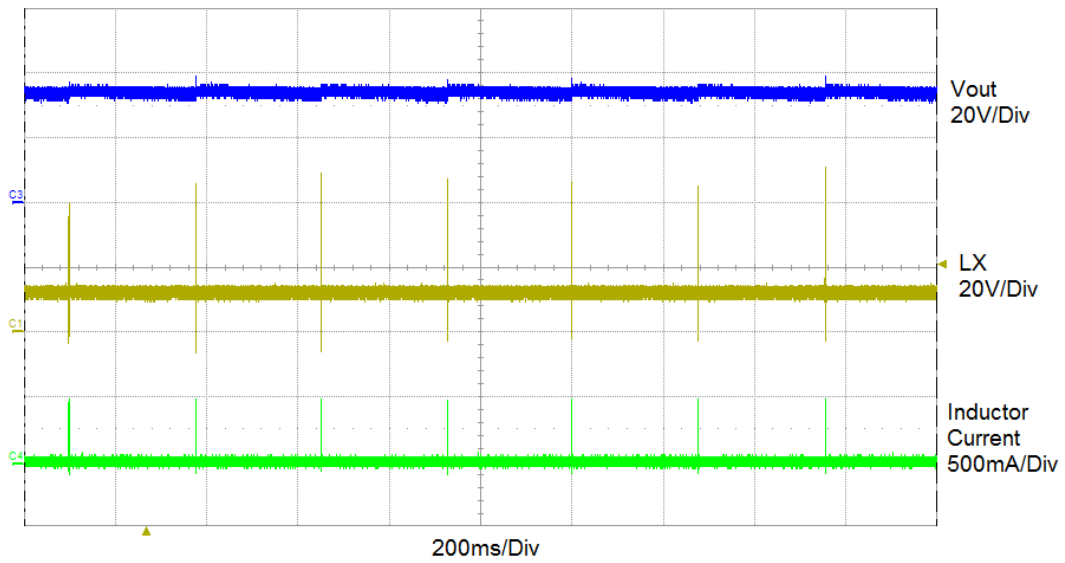

Figure 13 OVP waveform

# IS31LT3505

## Input and Output Capacitor

The output capacitor is decided by the output voltage ripple. A low ESR electric capacitor (22uF or larger) and a 1μF/50V ceramic capacitor in parallel will provide sufficient output capacitance for most applications. The input capacitor is used to reduce the input voltage ripple and noise. A low ESR electric capacitor (22uF or larger) and a 1μF/50V ceramic capacitor in parallel as output capacitor is recommended. Place the input and output capacitors close to the IS31LT3505 to reduce the ripple.

## Inductor

Inductor value involves trade-offs in performance. Larger inductors reduce inductor ripple current and larger inductors also bring in unwanted parasitic resistor that degrade the performance. Select an inductor with a rating current over input average current and the saturation current over the Internal NMOS current limit. A 10μH inductor with saturation current over 2A is sufficient for the most applications.

## Diode

To achieve high efficiency, a Schottky diode must be used. Ensure that the diode's average and peak current rating exceed the output LED current and inductor peak current. The diode's reverse breakdown voltage must exceed the over voltage protection voltage ( $V_{OVP}$ ). Therefore, A SS26 Schottky diode is sufficient for the most applications.

## Soft-start

The function of soft-start is made for suppressing the inrush current to an acceptable value at startup. The IS31LT3505 provides a built-in soft-start function by clamping the input current and increasing step-by-step so that the output voltage will rise gradually in the soft-start period.

## LED Current Control

The IS31LT3505 regulates the LED current by setting the external resistor connecting to feedback and ground. The internal feedback reference voltage is 0.3V(Typ.). The LED current can be set from the Formula (1) easily.

$$I_{LED} = V_{FB}/R_{SET} \quad (1)$$

In order to have an accurate LED current, precision resistors are preferred (1% is recommended).

## Dimming Control

IS31LT3505 can modulate the brightness of LEDs by controlling the DC voltage or the PWM duty cycle (Figure 14, 15).

Note: The DC voltage (PWM duty cycle) is inversely proportional to the LED current. That is when DC voltage is maximum (the PWM signal is 100% duty cycle), the output current is minimum, ideally zero, and when DC voltage is minimum (the PWM signal is 0% duty cycle), the output current is maximum.

The output LED voltage will decrease when the output current becomes lower. Therefore, it must be ensure that the output voltage always higher than the input voltage during the dimming.

## DC Voltage Control

Figure 14 shows that the intensity of the LEDs can be adjusted by the DC voltage. As the DC voltage increases, the current pass through R3 increasingly and the voltage drop on R3 increases, i.e. the LED current decreases. The LED current can be calculated by the Formula (2). The internal feedback voltage  $V_{FB}$  is 0.3V (Typ.).

$$I_{LED} = \frac{V_{FB} - \frac{R_3 \times (V_{DC} - V_{FB})}{R_4}}{R_{SET}} \quad (2)$$

When the DC voltage is from 0V to 5V, the value of R3 should be 10kΩ. Refer to Figure 14.

## PWM Signal Control

A filtered PWM signal acts as the DC voltage to regulate the output current. The recommended application circuit is shown as Figure 15. In this circuit, the output ripple depends on the frequency of PWM signal. For smaller output voltage ripple, the recommended frequency of 5V PWM signal should be above 2KHz. To the fixed frequency of PWM signal and change the duty cycle of PWM signal can get different output current. The LED current can be calculated by the Formula (3). The internal feedback voltage  $V_{FB}$  is 0.3V (Typ.).

$$I_{LED} = \frac{V_{FB} - \frac{R_3 \times (V_{PWM} \times Duty - V_{FB})}{R_4 + R_5}}{R_{SET}} \quad (3)$$

When it's the 5V PWM signal, the value of R3 should be 10kΩ. Refer to Figure 15.

## Setting the Output Voltage

When IS31LT3505 drives other devices (Figure 16) with the constant voltage, the output voltage is set through the Formula (4). The internal feedback voltage  $V_{FB}$  is 0.3V (Typ.).

$$V_{OUT} = V_{FB} \times (R_3 + R_{SET})/R_{SET} \quad (4)$$

## Setting the Over Voltage Protection

The open string protection is achieved through the over voltage protection (OVP). In some cases, if the output voltage reaches the programmed OVP voltage ( $V_{OVP}$ ), the protection will be triggered. To make sure the chip functions properly, the OVP setting resistor divider must be set with a proper value. The OVP voltage should be 3V higher than normal operation output voltage and the maximum should not exceed 35V. OVP pin should be connected to a 10nF ceramic

# IS31LT3505

capacitor to GND to avoid unexpected noise coupling into this pin and affecting the OVP function. The OVP threshold is calculated through the Formula (5).

$$V_{OVP} = 0.9V \times (R_1 + R_2) / R_2 \quad (5)$$

### Setting Other Components

There is a R, C between power supply positive terminal to VDD pin. A 300Ω resistor for R and 1μF ceramic capacitor for C are recommended. (Note: When the input voltage is lower than 8V, the recommended value of R is 50Ω)

The VP pin, output of the internal regulator, must be connected to a 10μF bypass capacitor.

If the EN pin is not used to enable and disable the IS31LT3505, it should be connected to power supply positive through a 100KΩ resistor. The enable pin needs to be terminated and should not be left floating.

### PCB layout consideration

As for all switching power supplies, especially those providing high current and using high switching frequencies, layout is an important design step. If layout is not carefully done, the regulator could show instability as well as EMI problems.

- Wide traces should be used for connection of the high current loop.
- When laying out the signal ground (pin 5), it is recommended to use the traces separate from power ground (pin1) traces and connect them together at the input capacitor negative terminal or

the large ground plane that will avoid the signal ground shift. Both of signal and power ground should be as wide as possible. Other components ground must be connected to signal ground. Especially the R<sub>SET</sub> ground to signal ground (pin 5) connection should be as short as possible to have an accurate LED current.

- The capacitor C<sub>VDD</sub> and C<sub>VP</sub> should be placed as close as possible to VDD and VP pin for good filtering.
- LX pin is a fast switching node. The inductor and diode should be placed as close as possible to the switch pin and the connection between this pin to the inductor and the Schottky diode should be kept as short and wide as possible. Avoid other traces crossing and routing too long in parallel with this node to minimum the noise coupling into these traces.
- The feedback network (FB, OVP) should be as short as possible and routed away from the inductor, the Schottky diode and LX pin. The feedback pin and feedback network should be shielded with a ground plane or trace to minimize noise coupling into this circuit.
- The thermal pad on the back of package must be soldered to the large ground plane for ideal power dissipation.

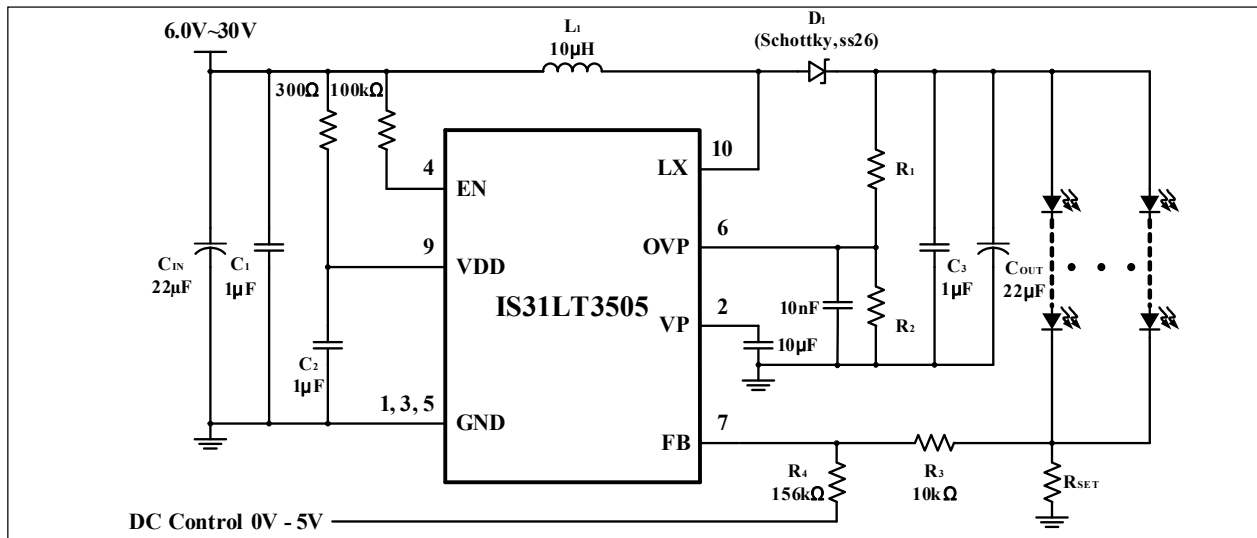

Figure 14 Application Circuit (Constant Current to Drive White LEDs With DC Dimming)



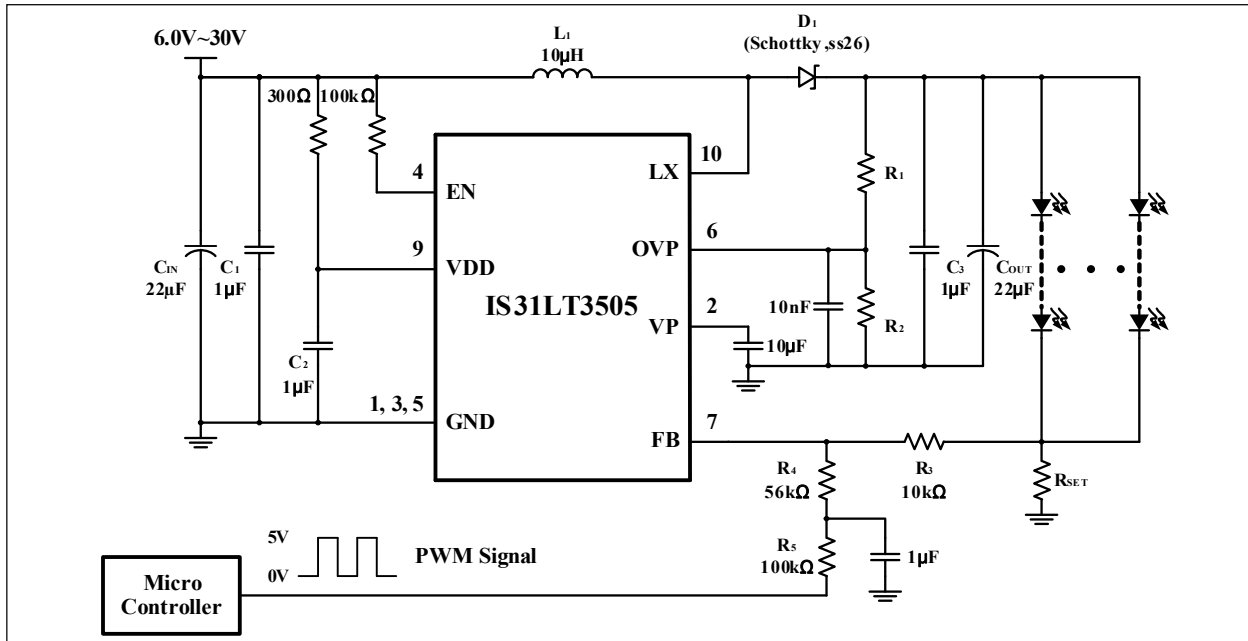

Figure 15 Application Circuit (Constant Current to Drive White LEDs With PWM Dimming)

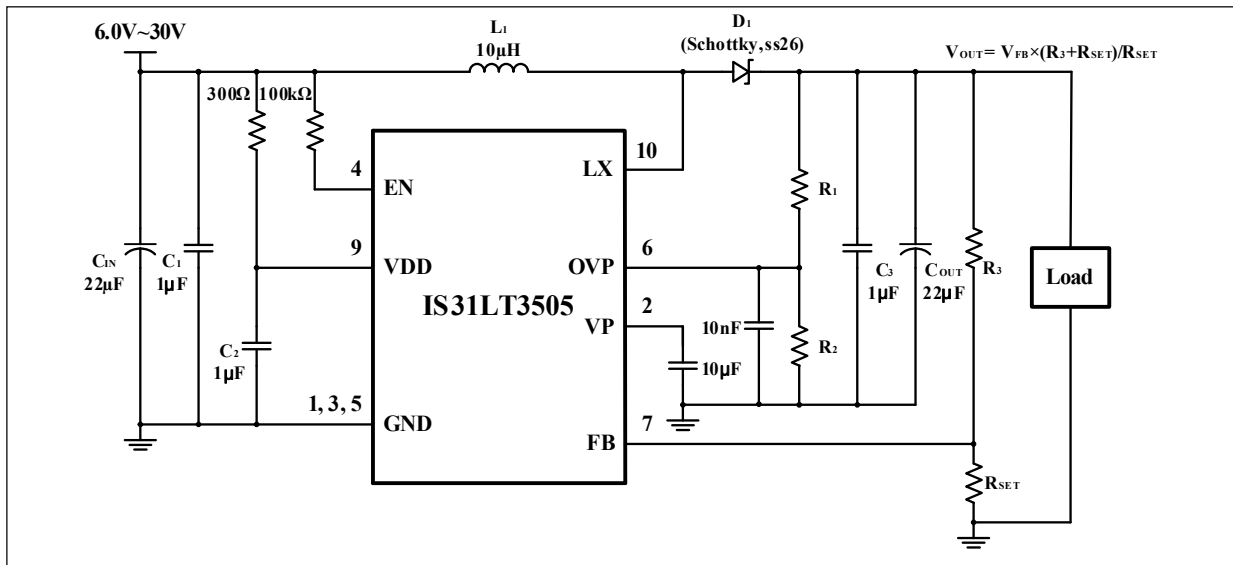

Figure 16 Application Circuit (Constant Voltage to Drive Other Devices)

## CLASSIFICATION REFLOW PROFILES

Profile Feature	Pb-Free Assembly
<b>Preheat &amp; Soak</b> Temperature min (T <sub>smin</sub> ) Temperature max (T <sub>smax</sub> ) Time (T <sub>smin</sub> to T <sub>smax</sub> ) (t <sub>s</sub> )	150°C 200°C 60-120 seconds
Average ramp-up rate (T <sub>smax</sub> to T <sub>p</sub> )	3°C/second max.
Liquidous temperature (T <sub>L</sub> ) Time at liquidous (t <sub>L</sub> )	217°C 60-150 seconds
Peak package body temperature (T <sub>p</sub> )*	Max 260°C
Time (t <sub>p</sub> )** within 5°C of the specified classification temperature (T <sub>c</sub> )	Max 30 seconds
Average ramp-down rate (T <sub>p</sub> to T <sub>smax</sub> )	6°C/second max.
Time 25°C to peak temperature	8 minutes max.

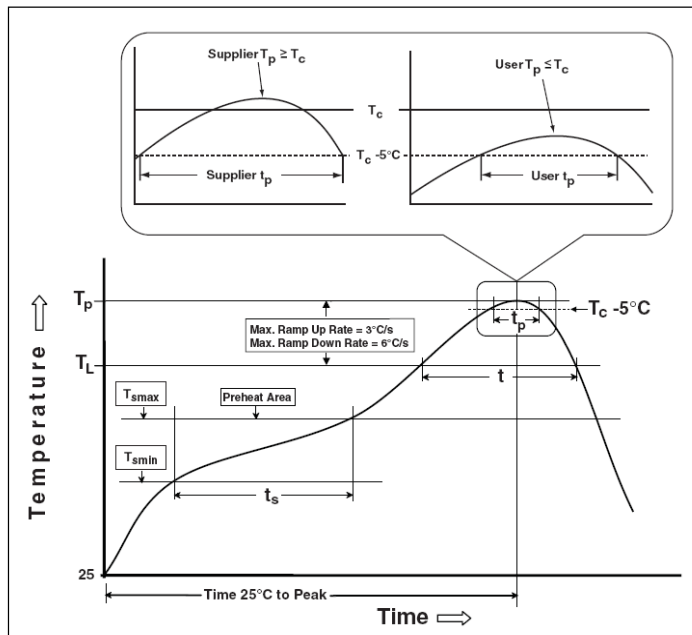
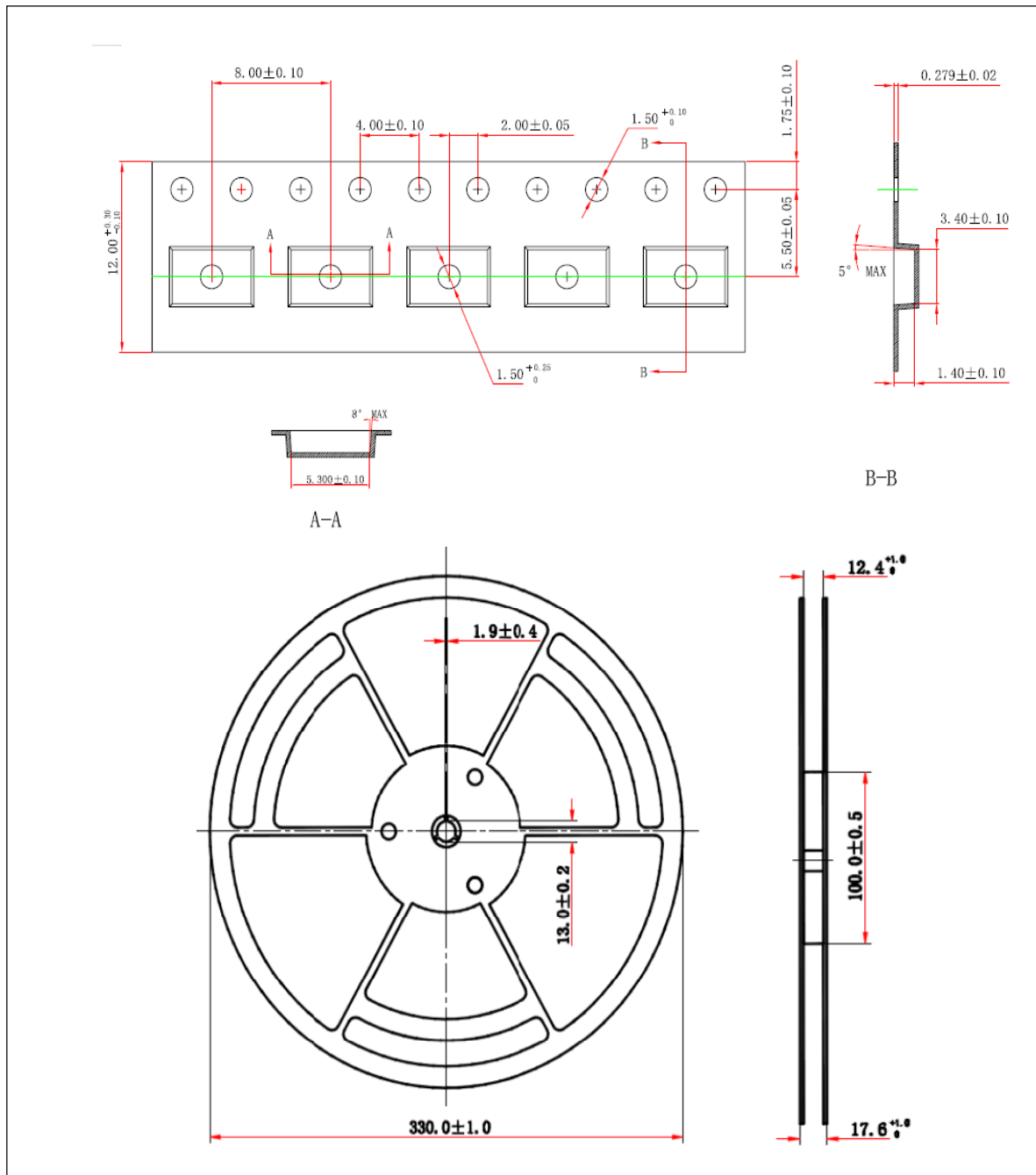

Figure 17 Classification Profile

# IS31LT3505

## TAPE AND REEL INFORMATION

### MSOP-10



# IS31LT3505

## PACKAGE INFORMATION

### MSOP-10

