

**PI7C21P100**  
**2-PORT PCI-X BRIDGE**  
REVISION 1.07



**3545 NORTH FIRST STREET  
SAN JOSE, CA 95134  
PH: 1-877-PERICOM (1-877-737-4266)  
FAX: 1-408-435-1100  
EMAIL: SOLUTIONS@PERICOM.COM  
INTERNET: HTTP://WWW.PERICOM.COM**

## **LIFE SUPPORT POLICY**

Pericom Semiconductor Corporation's products are not authorized for use as critical components in life support devices or systems unless a specific written agreement pertaining to such intended use is executed between the manufacturer and an officer of PSC.

- 1) Life support devices or system are devices or systems which:
  - a) Are intended for surgical implant into the body or
  - b) Support or sustain life and whose failure to perform, when properly used in accordance with instructions for use provided in the labeling, can be reasonably expected to result in a significant injury to the user.
- 2) A critical component is any component of a life support device or system whose failure to perform can be reasonably expected to cause the failure of the life support device or system, or to affect its safety or effectiveness. Pericom Semiconductor Corporation reserves the right to make changes to its products or specifications at any time, without notice, in order to improve design or performance and to supply the best possible product. Pericom Semiconductor does not assume any responsibility for use of any circuitry described other than the circuitry embodied in a Pericom Semiconductor product. The Company makes no representations that circuitry described herein is free from patent infringement or other rights of third parties which may result from its use. No license is granted by implication or otherwise under any patent, patent rights or other rights, of Pericom Semiconductor Corporation.

All other trademarks are of their respective companies.

## REVISION HISTORY

Date	Revision Number	Description
12/04/03	1.00	First Release of Data Sheet
12/11/03	1.01	Minor text corrections made.
01/22/04	1.02	Addition of Features section as well as a couple of tables.  Text corrections.
02/02/04	1.03	Corrected Device ID Register bits 11:0 descriptions.
03/15/04	1.04	Corrected pin designation for P_RST to E22 in section 3.2.1
09/13/04	1.05	Corrected C <sub>in</sub> max in section 10.2 (DC specifications) from 0.8pF to 8pF  Added power consumption data in Section 10.4
04/13/05	1.051	Corrected pin description for TEST_CE0 (Y23) in section 3.2.8
06/10/05	1.06	Correct package outline drawing in section 11  Added Pb-free & Green ordering information in section 12
07/05/05	1.07	Corrected Pb-free & Green ordering information from PI7C21P100NH to PI7C21P100NHE in section 12



*This page intentionally left blank.*

## TABLE OF CONTENTS

<b>1</b>	<b>DESCRIPTION.....</b>	<b>9</b>
<b>2</b>	<b>FEATURES.....</b>	<b>9</b>
<b>3</b>	<b>SIGNAL DEFINITIONS.....</b>	<b>10</b>
3.1	SIGNAL TYPES.....	10
3.2	SIGNALS.....	10
3.2.1	PRIMARY BUS INTERFACE SIGNALS.....	10
3.2.2	PRIMARY BUS INTERFACE SIGNALS – 64-BIT EXTENSION.....	12
3.2.3	SECONDARY BUS INTERFACE SIGNALS.....	13
3.2.4	SECONDARY BUS INTERFACE SIGNALS – 64-BIT EXTENSION.....	14
3.2.5	CLOCK SIGNALS.....	15
3.2.6	STRAPPING PINS AND MISCELLANEOUS SIGNALS.....	16
3.2.7	JTAG BOUNDARY SCAN AND TEST SIGNALS.....	17
3.2.8	TEST SIGNALS.....	18
3.2.9	POWER AND GROUND SIGNALS.....	18
3.3	PIN LIST.....	19
<b>4</b>	<b>PCI BUS OPERATION.....</b>	<b>22</b>
4.1	TYPES OF TRANSACTIONS.....	22
4.2	WRITE TRANSACTIONS.....	23
4.2.1	MEMORY WRITE TRANSACTIONS.....	23
4.2.1.1	PCI-X TO PCI-X.....	24
4.2.1.2	PCI TO PCI.....	24
4.2.1.3	PCI TO PCI-X.....	24
4.2.1.4	PCI-X TO PCI.....	25
4.2.2	DELAYED/SPLIT WRITE TRANSACTIONS.....	25
4.2.3	IMMEDIATE WRITE TRANSACTIONS.....	25
4.3	READ TRANSACTIONS.....	25
4.3.1	MEMORY READ TRANSACTIONS.....	26
4.3.1.1	PCI-X TO PCI-X.....	26
4.3.1.2	PCI TO PCI.....	26
4.3.1.3	PCI TO PCI-X.....	26
4.3.1.4	PCI-X TO PCI.....	27
4.3.2	I/O READ.....	27
4.3.3	CONFIGURATION READ.....	27
4.3.3.1	TYPE 1 CONFIGURATION READ.....	27
4.3.3.2	TYPE 0 CONFIGURATION READ.....	27
4.3.4	NON-PREFETCHABLE AND DWORD READS.....	28
4.3.5	PREFETCHABLE READS.....	28
4.3.5.1	PCI-X TO PCI-X AND PCI-X TO PCI.....	28
4.3.5.2	PCI TO PCI.....	28
4.3.5.3	PCI TO PCI-X.....	29
4.3.6	DYNAMIC PREFETCH (CONVENTIONAL PCI MODE ONLY).....	29
4.4	CONFIGURATION TRANSACTIONS.....	29
4.4.1	TYPE 0 ACCESS TO PI7C21P100.....	30
4.4.2	TYPE 1 TO TYPE 0 CONVERSION.....	30
4.4.3	TYPE 1 TO TYPE 1 FORWARDING.....	31
4.4.4	SPECIAL CYCLES.....	32
<b>5</b>	<b>TRANSACTION ORDERING.....</b>	<b>32</b>
5.1	GENERAL ORDERING GUIDELINES.....	33
5.2	ORDERING RULES.....	33
<b>6</b>	<b>CLOCKS.....</b>	<b>34</b>

6.1	PRIMARY AND SECONDARY CLOCK INPUTS.....	34
6.2	CLOCK JITTER.....	34
6.3	MODE AND CLOCK FREQUENCY DETERMINATION .....	34
6.3.1	PRIMARY BUS.....	34
6.3.2	SECONDARY BUS.....	35
6.3.3	CLOCK STABILITY.....	36
6.3.4	DRIVER IMPEDANCE SELECTION.....	36
<b>7</b>	<b>RESET .....</b>	<b>36</b>
7.1	PRIMARY INTERFACE RESET.....	37
7.2	SECONDARY INTERFACE RESET.....	37
7.3	BUS PARKING & BUS WIDTH DETERMINATION.....	38
7.4	SECONDARY DEVICE MASKING .....	38
7.5	ADDRESS PARITY ERRORS.....	39
7.6	OPTIONAL BASE ADDRESS REGISTER.....	39
7.7	OPTIONAL CONFIGURATION ACCESS FROM THE SECONDARY BUS .....	39
7.8	SHORT TERM CACHING.....	40
<b>8</b>	<b>CONFIGURATION REGISTERS.....</b>	<b>41</b>
8.1	CONFIGURATION REGISTER SPACE MAP .....	41
8.1.1.1	SIGNAL TYPE DEFINITION.....	42
8.1.2	VENDOR ID REGISTER – OFFSET 00h.....	42
8.1.3	DEVICE ID REGISTER – OFFSET 00h .....	42
8.1.4	COMMAND REGISTER – OFFSET 04h.....	42
8.1.5	PRIMARY STATUS REGISTER – OFFSET 04h .....	43
8.1.6	REVISION ID REGISTER – OFFSET 08h.....	44
8.1.7	CLASS CODE REGISTER – OFFSET 08h.....	44
8.1.8	CACHE LINE SIZE REGISTER – OFFSET 0Ch .....	44
8.1.9	PRIMARY LATENCY TIMER – OFFSET 0Ch.....	44
8.1.10	HEADER TYPE REGISTER – OFFSET 0Ch.....	44
8.1.11	BIST REGISTER – OFFSET 0Ch .....	44
8.1.12	LOWER MEMORY BASE ADDRESS REGISTER – OFFSET 10h.....	45
8.1.13	UPPER MEMORY BASE ADDRESS REGISTER – OFFSET 14h.....	45
8.1.14	PRIMARY BUS NUMBER REGISTER – OFFSET 18h.....	45
8.1.15	SECONDARY BUS NUMBER REGISTER – OFFSET 18h.....	45
8.1.16	SUBORDINATE BUS NUMBER REGISTER – OFFSET 18h.....	45
8.1.17	SECONDARY LATENCY TIMER REGISTER – OFFSET 18h.....	45
8.1.18	I/O BASE ADDRESS REGISTER – OFFSET 1Ch.....	46
8.1.19	I/O LIMIT REGISTER – OFFSET 1Ch.....	46
8.1.20	SECONDARY STATUS REGISTER – OFFSET 1Ch.....	46
8.1.21	MEMORY BASE REGISTER – OFFSET 20h.....	47
8.1.22	MEMORY LIMIT REGISTER – OFFSET 20h.....	47
8.1.23	PREFETCHABLE MEMORY BASE REGISTER – OFFSET 24h.....	47
8.1.24	PREFETCHABLE MEMORY LIMIT REGISTER – OFFSET 24h.....	47
8.1.25	PREFETCHABLE BASE UPPER 32-BIT REGISTER – OFFSET 28h.....	47
8.1.26	PREFETCHABLE LIMIT UPPER 32-BIT REGISTER – OFFSET 2Ch.....	48
8.1.27	I/O BASE UPPER 16-BIT REGISTER – OFFSET 30h.....	48
8.1.28	I/O LIMIT UPPER 16-BIT REGISTER – OFFSET 30h .....	48
8.1.29	CAPABILITY POINTER – OFFSET 34h.....	48
8.1.30	EXPANSION ROM BASE ADDRESS REGISTER – OFFSET 38h.....	48
8.1.31	INTERRUPT LINE REGISTER – OFFSET 3Ch.....	48
8.1.32	INTERRUPT PIN REGISTER – OFFSET 3Ch.....	48
8.1.33	BRIDGE CONTROL REGISTER – OFFSET 3Ch.....	49
8.1.34	PRIMARY DATA BUFFERING CONTROL REGISTER – OFFSET 40h.....	50
8.1.35	SECONDARY DATA BUFFERING CONTROL REGISTER – OFFSET 40h.....	51

8.1.36	MISCELLANEOUS CONTROL REGISTER – OFFSET 44h.....	52
8.1.37	EXTENDED CHIP CONTROL REGISTER 1 – OFFSET 48h.....	52
8.1.38	EXTENDED CHIP CONTROL REGISTER 2 – OFFSET 48h.....	53
8.1.39	ARBITER MODE REGISTER – OFFSET 50h.....	53
8.1.40	ARBITER ENABLE REGISTER – OFFSET 54h.....	54
8.1.41	ARBITER PRIORITY REGISTER – OFFSET 58h.....	54
8.1.42	SERR# DISABLE REGISTER – OFFSET 5Ch.....	55
8.1.43	PRIMARY RETRY COUNTER REGISTER – OFFSET 60h.....	56
8.1.44	SECONDARY RETRY COUNTER REGISTER – OFFSET 64h.....	56
8.1.45	DISCARD TIMER CONTROL REGISTER – OFFSET 68h.....	57
8.1.46	RETRY AND TIMER STATUS REGISTER – OFFSET 6Ch.....	57
8.1.47	OPAQUE MEMORY ENABLE REGISTER – OFFSET 70h.....	57
8.1.48	OPAQUE MEMORY BASE REGISTER – OFFSET 74h.....	58
8.1.49	OPAQUE MEMORY LIMIT REGISTER – OFFSET 74h.....	58
8.1.50	OPAQUE MEMORY BASE UPPER 32-BIT REGISTER – OFFSET 78h.....	58
8.1.51	OPAQUE MEMORY LIMIT UPPER 32-BIT REGISTER – OFFSET 7Ch.....	58
8.1.52	PCI-X CAPABILITY ID REGISTER – OFFSET 80h.....	58
8.1.53	NEXT CAPABILITY POINTER REGISTER – OFFSET 80h.....	59
8.1.54	PCI-X SECONDARY STATUS REGISTER – OFFSET 80h.....	59
8.1.55	PCI-X BRIDGE PRIMARY STATUS REGISTER – OFFSET 84h.....	59
8.1.56	SECONDARY BUS UPSTREAM SPLIT TRANSACTION REGISTER – OFFSET 88h ...	61
8.1.57	PRIMARY BUS DOWNSTREAM SPLIT TRANSACTION REGISTER – OFFSET 8Ch..	61
8.1.58	POWER MANAGEMENT ID REGISTER – OFFSET 90h.....	61
8.1.59	NEXT CAPABILITIES POINTER REGISTER – OFFSET 90h.....	62
8.1.60	POWER MANAGEMENT CAPABILITIES REGISTER – OFFSET 90h.....	62
8.1.61	POWER MANAGEMENT CONTROL AND STATUS REGISTER – OFFSET 94h.....	62
8.1.62	PCI-TO-PCI BRIDGE SUPPORT EXTENSION REGISTER – OFFSET 94h.....	63
8.1.63	SECONDARY BUS PRIVATE DEVICE MASK REGISTER – OFFSET B0h.....	63
8.1.64	MISCELLANEOUS CONTROL REGISTER 2 – OFFSET B8h.....	64
<b>9</b>	<b>IEEE 1149.1 COMPATIBLE JTAG CONTROLLER.....</b>	<b>65</b>
9.1	INSTRUCTION REGISTER.....	65
9.2	BYPASS REGISTER.....	65
9.3	DEVICE ID REGISTER.....	65
9.4	BOUNDARY SCAN REGISTER.....	66
9.5	JTAG BOUNDARY REGISTER ORDER.....	66
<b>10</b>	<b>ELECTRICAL INFORMATION.....</b>	<b>74</b>
10.1	MAXIMUM RATINGS.....	74
10.2	DC SPECIFICATIONS.....	74
10.3	AC SPECIFICATIONS.....	74
10.4	POWER CONSUMPTION.....	75
<b>11</b>	<b>MECHANICAL INFORMATION.....</b>	<b>76</b>
<b>12</b>	<b>ORDERING INFORMATION.....</b>	<b>76</b>

## LIST OF TABLES

TABLE 3-1 PIN LIST 304-PIN PBGA .....	19
TABLE 4-1 PCI AND PCI-X TRANSACTIONS .....	22
TABLE 4-2 WRITE TRANSACTION FORWARDING.....	23
TABLE 4-3 READ TRANSACTIONS HANDLING .....	25
TABLE 4-4 DEVICE NUMBER TO IDSEL .....	31
TABLE 5-1 SUMMARY OF TRANSACTION ORDERING IN PCI MODE .....	33
TABLE 5-2 SUMMARY OF TRANSACTION ORDERING IN PCI-X MODE.....	33
TABLE 6-1 PROGRAMMABLE PULL-UP CIRCUIT .....	35
TABLE 6-2 DRIVER IMPEDANCE SELECTION .....	36
TABLE 7-1 DELAY TIMES FOR DE-ASSERTION OF S_RST# .....	38
TABLE 7-2 DE-ASSERTION OF S_RST# .....	38
TABLE 8-1 CONFIGURATION SPACE MAP .....	41
TABLE 9-1 JTAG BOUNDARY SCAN REGISTER .....	66
TABLE 10-1 AC TIMING SPECIFICATIONS PCI-X MODE.....	75
TABLE 10-2 AC TIMING SPECIFICATIONS CONVENTIONAL PCI MODE.....	75

## LIST OF FIGURES

FIGURE 10-1 PCI SIGNAL TIMING MEASUREMENTS .....	74
FIGURE 11-1 PACKAGE DIAGRAM 31 X 31MM 304-PIN HPBGA .....	76



## 1 DESCRIPTION

The PI7C21P100 is a 2-port PCI-X 2.0 Bridge designed to be compliant with the *PCI-X Addendum to the Local Bus Specification* Revision 1.0a. The PI7C21P100 is able to handle 64-bit data at a maximum bus frequency of 133MHz. The PI7C21P100 is designed for high speed applications such as Ethernet, SCSI, and Fibre Channel. The PI7C21P100 may also be used for bus expansion, frequency isolations/translations, or PCI-X to PCI isolations/translations.

## 2 FEATURES

- **INDUSTRY STANDARDS COMPLIANCE**
  - *PCI-X Addendum to the Local Bus Specification* Revision 1.0a (Mode 1 only)
  - *PCI Local Bus Specification* Revision 2.2
  - *PCI-to-PCI Bridge Architecture Specification* Revision 1.1
  - *PCI Power Management Interface Specification* Revision 1.1
    - Supports D0 and D3 power states
- **INTERFACE**
  - 3.3V signaling with 5V tolerance
  - 133MHz / 64-bit operation on both buses
  - Dual address cycle support
  - Concurrent primary and secondary bus operation
  - Primary and secondary may be run in either PCI mode or PCI-X Mode 1
  - Asynchronous operation support
  - Programmable internal arbiter with support for up to 6 external masters on the secondary bus
    - Internal arbiter may be disabled to use an external arbiter
  - IEEE 1149.1 JTAG support
- **OPERATION**
  - Type 0 and Type 1 configuration support
  - Configuration register access from both primary and secondary buses
  - 2KB of buffering for upstream memory burst read commands
  - 2KB of buffering for downstream memory burst read commands
  - 1KB of buffering for upstream posted memory write commands
  - 1KB of buffering for downstream posted memory write commands
  - Support for up to 8 active transactions in each direction
- **ADDITIONAL FEATURES**
  - Capabilities pointer
  - Ability to define an opaque memory address
  - Definable base address register
  - Secondary side PCI-X device privatization
- **PACKAGING**
  - 304-pin PBGA, 31 x 31 mm

## 3 SIGNAL DEFINITIONS

### 3.1 SIGNAL TYPES

Signal Type	Description
I	Input Only
O	Output Only
P	Power
TS	Tri-State bi-directional
STS	Sustained Tri-State. Active LOW signal must be pulled HIGH for 1 cycle when deasserting.
OD	Open Drain
IU	Internal pull-up on signal
ID	Internal pull-down on signal

### 3.2 SIGNALS

Signal names that end with “#” are active LOW.

#### 3.2.1 PRIMARY BUS INTERFACE SIGNALS

Name	Pin #	Type	Description
P_AD[31:0]	J23, M21, M22, L21, L22, G23, K20, E23, K21, D23, K22, J21, J22, H21, H22, G21, B20, G22, F20, F22, D18, C19, C17, B17, A20, C16, B16, A19, C15, B14, C13, B13	TS	<b>Primary Address / Data:</b> Multiplexed address and data bus. Address is indicated by P_FRAME# assertion. Write data is stable and valid when P_IRDY# is asserted and read data is stable and valid when P_TRDY# is asserted. Data is transferred on rising clock edges when both P_IRDY# and P_TRDY# are asserted. During bus idle, PI7C21P100 drives P_AD[31:0] to a valid logic level when P_GNT# is asserted.
P_CBE[3:0]#	A15, D14, B18, A13	TS	<b>Primary Command/Byte Enables:</b> Multiplexed command field and byte enable field. During address phase, the initiator drives the transaction type on these pins. After that, the initiator drives the byte enables during data phases. During bus idle, PI7C21P100 drives P_CBE[3:0]# to a valid logic level when P_GNT# is asserted.
P_PAR	C18	TS	<b>Primary Parity.</b> P_PAR is even parity of P_AD[31:0] and P_CBE[3:0] (i.e. an even number of 1's). P_PAR is valid and stable one cycle after the address phase (indicated by assertion of P_FRAME#) for address parity. For write data phases, P_PAR is valid one clock after P_IRDY# is asserted. For read data phase, P_PAR is valid one clock after P_TRDY# is asserted. Signal P_PAR is tri-stated one cycle after the P_AD lines are tri-stated. During bus idle, PI7C21P100 drives P_PAR to a valid logic level when P_GNT# is asserted.
P_FRAME#	A17	STS	<b>Primary FRAME (Active LOW).</b> Driven by the initiator of a transaction to indicate the beginning and duration of an access. The de-assertion of P_FRAME# indicates the final data phase requested by the initiator. Before being tri-stated, it is driven HIGH for one cycle.
P_IRDY#	A16	STS	<b>Primary IRDY (Active LOW).</b> Driven by the initiator of a transaction to indicate its ability to complete current data phase on the primary side. Once asserted in a data phase, it is not de-asserted until the end of the data phase. Before tri-stated, it is driven HIGH for one cycle.

Name	Pin #	Type	Description
P_TRDY#	B15	STS	<b>Primary TRDY (Active LOW).</b> Driven by the target of a transaction to indicate its ability to complete current data phase on the primary side. Once asserted in a data phase, it is not de-asserted until the end of the data phase. Before tri-stated, it is driven HIGH for one cycle.
P_DEVSEL#	D21	STS	<b>Primary Device Select (Active LOW).</b> Asserted by the target indicating that the device is accepting the transaction. As a master, PI7C21P100 waits for the assertion of this signal within 5 cycles of P_FRAME# assertion; otherwise, terminate with master abort. Before tri-stated, it is driven HIGH for one cycle.
P_STOP#	C4	STS	<b>Primary STOP (Active LOW).</b> Asserted by the target indicating that the target is requesting the initiator to stop the current transaction. Before tri-stated, it is driven HIGH for one cycle.
P_LOCK#	C14	I	<b>Primary LOCK (Active LOW).</b> Asserted by an initiator, one clock cycle after the first address phase of a transaction, attempting to perform an operation that may take more than one PCI transaction to complete.
P_IDSEL	B19	I	<b>Primary ID Select.</b> Used as a chip select line for Type 0 configuration access to PI721P100 configuration space.
P_PERR#	C8	STS	<b>Primary Parity Error (Active LOW).</b> Asserted when a data parity error is detected for data received on the primary interface. Before being tri-stated, it is driven HIGH for one cycle.
P_SERR#	B4	OD	<b>Primary System Error (Active LOW).</b> Can be driven LOW by any device to indicate a system error condition. PI7C21P100 drives this pin on: <ul style="list-style-type: none"> <li>▪ Address parity error</li> <li>▪ Posted write data parity error on target bus</li> <li>▪ Secondary S_SERR# asserted</li> <li>▪ Master abort during posted write transaction</li> <li>▪ Target abort during posted write transaction</li> <li>▪ Posted write transaction discarded</li> <li>▪ Delayed write request discarded</li> <li>▪ Delayed read request discarded</li> <li>▪ Delayed transaction master timeout</li> </ul> This signal requires an external pull-up resistor for proper operation.
P_REQ#	B21	TS	<b>Primary Request (Active LOW):</b> This is asserted by PI7C21P100 to indicate that it wants to start a transaction on the primary bus. PI7C21P100 de-asserts this pin for at least 2 PCI clock cycles before asserting it again.
P_GNT#	C20	I	<b>Primary Grant (Active LOW):</b> When asserted, PI7C21P100 can access the primary bus. During idle and P_GNT# asserted, PI7C21P100 will drive P_AD, P_CBE, and P_PAR to valid logic levels.
P_RST#	E22	I	<b>Primary RESET (Active LOW):</b> When P_RESET# is active, all PCI signals should be asynchronously tri-stated.

### 3.2.2 PRIMARY BUS INTERFACE SIGNALS – 64-BIT EXTENSION

Name	Pin #	Type	Description
P_AD[63:32]	B11, D10, C10, A4, B10, C9, B9, A3, B8, B3, C7, B7, D6, B6, B5, C2, D2, F4, E3, F3, B1, F2, G3, H3, H2, E1, J3, G1, H1, J2, J1, L1	TS	<b>Primary Upper 32-bit Address / Data:</b> Multiplexed address and data bus providing an additional 32 bits to the primary. When a dual address command is used and P_REQ64# is asserted, the initiator drives the upper 32 bits of the 64-bit address. Otherwise, these bits are undefined and driven to valid logic levels. During the data phase of a transaction, the initiator drives the upper 32 bits of the 64-bit write data, or the target drives the upper 32 bits of the 64-bit read data, when P_REQ64# and P_ACK64# are both asserted. Otherwise, these bits are pulled up to a valid logic level through external resistors.
P_CBE[7:4]#	A7, B12, C11, A5	TS	<b>Primary Upper 32-bit Command/Byte Enables:</b> Multiplexed command field and byte enable field. During address phase, when the dual address command is used and P_REQ64# is asserted, the initiator drives the transaction type on these pins. Otherwise, these bits are undefined, and the initiator drives a valid logic level onto the pins. For read and write transactions, the initiator drives these bits for the P_AD[63:32] data bits when P_REQ64# and P_ACK64# are both asserted. When not driven, these bits are pulled up to a valid logic level through external resistors.
P_PAR64	A9	TS	<b>Primary Upper 32-bit Parity:</b> P_PAR64 carries the even parity of P_AD[63:32] and P_CBE[7:4] for both address and data phases. P_PAR64 is driven by the initiator and is valid 1 cycle after the first address phase when a dual address command is used and P_REQ64# is asserted. P_PAR64 is valid 1 clock cycle after the second address phase of a dual address transaction when P_REQ64# is asserted. P_PAR64 is valid 1 cycle after valid data is driven when both P_REQ64# and P_ACK64# are asserted for that data phase. P_PAR64 is driven by the device driving read or write data 1 cycle after the P_AD lines are driven. P_PAR64 is tri-stated 1 cycle after the P_AD lines are tri-stated. Devices receive data sample P_PAR64 as an input to check for possible parity errors during 64-bit transactions. When not driven, P_PAR64 is pulled up to a valid logic level through external resistors.
P_REQ64#	C12	STS	<b>Primary 64-bit Transfer Request:</b> P_REQ64# is asserted by the initiator to indicate that the initiator is requesting a 64-bit data transfer. P_REQ64# has the same timing as P_FRAME#. When P_REQ64# is asserted LOW during reset, a 64-bit data path is supported. When P_REQ64# is HIGH during reset, PI7C21P100 drives P_AD[63:32], P_CBE[7:4], and P_PAR64 to valid logic levels. When deasserting, P_REQ64# is driven HIGH for 1 cycle and then sustained by an external pull-up resistor.
P_ACK64#	A2	STS	<b>Primary 64-bit Transfer Acknowledge:</b> P_ACK64# is asserted by the target only when P_REQ64# is asserted by the initiator to indicate the target's ability to transfer data using 64 bits. P_ACK64# has the same timing as P_DEVSEL#. When deasserting, P_ACK64# is driven HIGH for 1 cycle and then is sustained by an external pull-up resistor.

### 3.2.3 SECONDARY BUS INTERFACE SIGNALS

Name	Pin #	Type	Description
S_AD[31:0]	N22, N21, P22, P21, M23, P20, N23, R22, T23, R21, W23, T22, U22, U21, V22, V21, W21, V20, AA20, AB18, Y18, AA16, AB15, AC17, AA13, AA12, AC15, AB11, AC11, AC9, AB9, AA9	TS	<b>Secondary Address/Data:</b> Multiplexed address and data bus. Address is indicated by S_FRAME# assertion. Write data is stable and valid when S_IRDY# is asserted and read data is stable and valid when S_IRDY# is asserted. Data is transferred on rising clock edges when both S_IRDY# and S_TRDY# are asserted. During bus idle, PI7C21P100 drives S_AD[31:0] to a valid logic level when the bridge is granted the bus.
S_CBE[3:0]#	AA15, AB14, AB16, AB12	TS	<b>Secondary Command/Byte Enables:</b> Multiplexed command field and byte enable field. During address phase, the initiator drives the transaction type on these pins. The initiator then drives the byte enables during data phases. During bus idle, PI7C21P100 drives S_CBE[3:0] to a valid logic level when the bridge is granted the bus.
S_PAR	AA17	TS	<b>Secondary Parity:</b> S_PAR is an even parity of S_AD[31:0] and S_CBE[3:0] (i.e. an even number of 1's). S_PAR is valid and stable one cycle after the address phase (indicated by assertion of S_FRAME#) for address parity. For write data phases, S_PAR is valid one clock after S_IRDY# is asserted. For read data phase, S_PAR is valid one clock after S_TRDY# is asserted. Signal S_PAR is tri-stated one cycle after the S_AD lines are tri-stated. During bus idle, PI7C21P100 drives S_PAR to a valid logic level when the bridge is granted the bus.
S_FRAME#	AA14	STS	<b>Secondary FRAME (Active LOW):</b> Driven by the initiator of a transaction to indicate the beginning and duration of an access. The de-assertion of S_FRAME# indicates the final data phase requested by the initiator. Before being tri-stated, it is driven HIGH for one cycle.
S_IRDY#	AC19	STS	<b>Secondary IRDY (Active LOW):</b> Driven by the initiator of a transaction to indicate its ability to complete current data phase on the secondary side. Once asserted in a data phase, it is not de-asserted until the end of the data phase. Before tri-stated, it is driven HIGH for one cycle.
S_TRDY#	Y14	STS	<b>Secondary TRDY (Active LOW):</b> Driven by the target of a transaction to indicate its ability to complete current data phase on the secondary side. Once asserted in a data phase, it is not de-asserted until the end of the data phase. Before tri-stated, it is driven HIGH for one cycle.
S_DEVSEL#	AC21	STS	<b>Secondary Device Select (Active LOW):</b> Asserted by the target indicating that the device is accepting the transaction. As a master, PI7C21P100 waits for the assertion of this signal within 5 cycles of S_FRAME# assertion; otherwise, terminate with master abort. Before tri-stated, it is driven HIGH for one cycle.
S_STOP#	AB20	STS	<b>Secondary STOP (Active LOW):</b> Asserted by the target indicating that the target is requesting the initiator to stop the current transaction. Before tri-stated, it is driven HIGH for one cycle.
S_LOCK#	AC20	STS	<b>Secondary LOCK (Active LOW):</b> Asserted by an initiator, one clock cycle after the first address phase of a transaction, when it is propagating a locked transaction downstream. PI7C21P100 does not propagate locked transactions upstream.
S_PERR#	AB17	STS	<b>Secondary Parity Error (Active LOW):</b> Asserted when a data parity error is detected for data received on the secondary interface. Before being tri-stated, it is driven HIGH for one cycle.

Name	Pin #	Type	Description
S_SERR#	AB19	I	<b>Secondary System Error (Active LOW):</b> Can be driven LOW by any device to indicate a system error condition.
S_REQ[6:2]#	AC3, AB5, AB3, W2, AA2	I	<b>Secondary Request (Active LOW):</b> This is asserted by an external device to indicate that it wants to start a transaction on the secondary bus. The input is externally pulled up through a resistor to VDD.
S_REQ[1]#	AA23	I	<b>Secondary Request (Active LOW):</b> When the internal arbiter is enabled, this is asserted by an external device to indicate that it wants to start a transaction on the secondary bus. The input is externally pulled up through a resistor to VDD.  When the internal arbiter is disabled, this is used by PI7C21P100 as its GNT input.
S_GNT[6:2]#	AC4, AB4, AC5, Y2, AB1	TS	<b>Secondary Grant (Active LOW):</b> PI7C21P100 asserts these pins to allow external masters to access the secondary bus. PI7C21P100 de-asserts these pins for at least 2 PCI clock cycles before asserting it again. During idle and S_GNT# deasserted, PI7C21P100 will drive S_AD, S_CBE, and S_PAR.
S_GNT[1]#	AA19	TS	<b>Secondary Grant (Active LOW):</b> When the internal arbiter is enabled, PI7C21P100 asserts this pin to allow external masters to access the secondary bus. PI7C21P100 de-asserts this pin for at least 2 PCI clock cycles before asserting it again. During idle and S_GNT# deasserted, PI7C21P100 will drive S_AD, S_CBE, and S_PAR.  When the internal arbiter is disabled, this is used by PI7C21P100 as its REQ output.
S_RST#	U23	O	<b>Secondary RESET (Active LOW):</b> Asserted when any of the following conditions are met: <ol style="list-style-type: none"> <li>Signal P_RESET# is asserted.</li> <li>Secondary reset bit in bridge control register in configuration space is set.</li> <li>The chip reset bit in the chip control register in configuration space is set.</li> </ol> When asserted, all control signals are tri-stated and zeroes are driven on S_AD, S_CBE, S_PAR, and S_PAR64.

### 3.2.4 SECONDARY BUS INTERFACE SIGNALS – 64-BIT EXTENSION

Name	Pin #	Type	Description
S_AD[63:32]	AB8, AB7, AA7, AB6, AA6, AA5, Y6, Y3, V2, V4, U2, U3, T2, T3, R2, R3, P2, Y1, P3, W1, P4, U1, N2, N3, M2, M3, R1, L2, L3, K2, K3, K4	TS	<b>Secondary Upper 32-bit Address/Data:</b> Multiplexed address and data bus. Address is indicated by S_FRAME# assertion. Write data is stable and valid when S_IRDY# is asserted and read data is stable and valid when S_IRDY# is asserted. Data is transferred on rising clock edges when both S_IRDY# and S_TRDY# are asserted. During bus idle, PI7C21P100 drives S_AD to a valid logic level when the bridge is granted the bus.
S_CBE[7:4]#	Y10, AB10, AA11, AC8	TS	<b>Secondary Upper 32-bit Command/Byte Enables:</b> Multiplexed command field and byte enable field. During address phase, the initiator drives the transaction type on these pins. The initiator then drives the byte enables during data phases. During bus idle, PI7C21P100 drives S_CBE[7:0] to a valid logic level when the bridge is granted the bus.

Name	Pin #	Type	Description
S_PAR64	AA10	TS	<b>Secondary Upper 32-bit Parity:</b> S_PAR64 carries the even parity of S_AD[63:32] and S_CBE[7:4] for both address and data phases. S_PAR64 is driven by the initiator and is valid 1 cycle after the first address phase when a dual address command is used and S_REQ64# is asserted. S_PAR64 is valid 1 clock cycle after the second address phase of a dual address transaction when S_REQ64# is asserted. S_PAR64 is valid 1 cycle after valid data is driven when both S_REQ64# and S_ACK64# are asserted for that data phase. S_PAR64 is driven by the device driving read or write data 1 cycle after the S_AD lines are driven. S_PAR64 is tri-stated 1 cycle after the S_AD lines are tri-stated. Devices receive data sample S_PAR64 as an input to check for possible parity errors during 64-bit transactions. When not driven, S_PAR64 is pulled up to a valid logic level through external resistors.
S_REQ64#	AB13	STS	<b>Secondary 64-bit Transfer Request:</b> S_REQ64# is asserted by the initiator to indicate that the initiator is requesting a 64-bit data transfer. S_REQ64# has the same timing as S_FRAME#. When S_REQ64# is asserted LOW during reset, a 64-bit data path is supported. When S_REQ64# is HIGH during reset, PI7C21P100 drives S_AD[63:32], S_CBE[7:4], and S_PAR64 to valid logic levels. When deasserting, S_REQ64# is driven to a deasserted state for 1 cycle and then sustained by an external pull-up resistor.
S_ACK64#	AA8	STS	<b>Secondary 64-bit Transfer Acknowledge:</b> S_ACK64# is asserted by the target only when S_REQ64# is asserted by the initiator to indicate the target's ability to transfer data using 64 bits. S_ACK64# has the same timing as S_DEVSEL#. When deasserting, S_ACK64# is driven to a deasserted state for 1 cycle and then is sustained by an external pull-up resistor.

### 3.2.5 CLOCK SIGNALS

Name	Pin #	Type	Description
P_CLK	E21	I	<b>Primary Clock Input:</b> Provides timing for all transactions on the primary interface. For conventional PCI mode, the input clock frequency may be between 0 – 66MHz. In PCI-X mode, the input clock frequency may be between 66 – 133MHz. See Section 6 for limitations.
S_CLK	AB23	I	<b>Secondary Clock Input:</b> Provides timing for all transactions on the secondary interface. For conventional PCI mode, the input clock frequency may be between 0 – 66MHz. In PCI-X mode, the input clock frequency may be between 66 – 133MHz. See Section 6 for limitations. If the primary bus is running at 133MHz, the minimum frequency that may be supplied to S_CLK is 33MHz.

### 3.2.6 STRAPPING PINS AND MISCELLANEOUS SIGNALS

Name	Pin #	Type	Description
S_ARB#	T21	I	<p><b>Internal Arbiter Enable:</b> This pin is used by PI7C21P100 to determine whether the secondary bus uses the internal arbiter or external arbiter.</p> <p>0: Enable the internal arbiter</p> <p>1: Disable the internal arbiter and use an external arbiter</p>
S_SEL100	V3	I	<p><b>Secondary Bus Maximum Frequency:</b> This pin is used to determine the maximum frequency on the secondary bus when in PCI-X mode. In PCI mode, the pin has no function and should not be left floating.</p> <p>0: Set secondary interface to 133MHz</p> <p>1: Set secondary interface to 100MHz</p>
S_PCIXCAP	R23	I	<p><b>Secondary Bus PCI-X Capable:</b> This pin is used with S_SEL100 to determine the frequency and mode for the secondary bus. There are three conditions for this pin determining the capability of the secondary bus:</p> <p>Ground: Not capable of PCI-X mode</p> <p>Pull-down: PCI-X 66MHz</p> <p>Not connected: PCI-X 133MHz</p>
S_PCIXCAP_PU	AA1	I	<p><b>S_PCIXCAP Pull-up Driver:</b> This pin is used with S_PCIXAP as part of a programmable pull-up circuit to determine the state of S_PCIXCAP. A 1kohm resistor must be placed between this pin and S_PCIXCAP.</p>
S_DRVR	AC7	ID	<p><b>Secondary Driver Mode:</b> This pin controls the output impedance of the secondary drivers to account for the number of loads on the secondary bus.</p> <p>0: default impedance</p> <p>1: select alternate impedance</p> <p>See Table 6-2 for impedance values.</p>
P_DRVR	E2	ID	<p><b>Primary Driver Mode Control:</b> Controls the output impedance of the primary bus drivers to account for the number of loads on the primary bus.</p> <p>0: Default impedance</p> <p>1: Select alternate impedance</p>
S_CLK_STABLE	W3	I	<p><b>S_CLK Input Stable:</b> Determines when the S_CLK is stable to resolve when S_RST# can be de-asserted.</p> <p>0: S_CLK is not stable</p> <p>1: S_CLK is stable</p>
S_IDSEL	AA22	I	<p><b>Initialization Device Select:</b> S_IDSEL is used as a chip select during configuration reads and writes on the secondary bus. Applications that do not require access to PI7C21P100's configuration registers from the secondary side should pull this pin LOW.</p>



64BIT_DEV#	Y22	I	<p><b>PCI-X Device Bus Width:</b> 64BIT_DEV# sets bit 16 of the PCI-X Bridge Status Register to support system management software. This signal does not change the behavior of the bridge.</p> <p>0: Sets bit 16 of the PCI-X bridge status register to 1</p> <p>1: Sets bit 16 of the PCI-X bridge status register to 0</p>
BAR_EN	G2	I	<p><b>Base Address Register Enable:</b> BAR_EN is used to enable the base address at reset or power up. When enabled, the 64-bit register at offset 10h and offset 14h is used to claim a 1MB memory region.</p> <p>0: Disabled – register returns 0 and no memory region is claimed</p> <p>1: Enabled – bits 63:20 can be written by software to claim a 1MB memory region</p>
IDSEL_ROUTE	AC22	I	<p><b>IDSEL Reroute Enable:</b> Controls the IDSEL reroute function at reset or power up. The reset value of the secondary bus private device mask register is changed according to the value of this pin.</p> <p>0: Reset value of the secondary bus private device mask register is 00000000h</p> <p>1: Reset value of the secondary bus private device mask register is 22F20000h</p>
OPAQUE_EN	AA18	I	<p><b>Opaque Region Enable:</b> Used to enable the opaque memory region at reset or power up. Controls bit[0] offset 70h.</p> <p>0: Disable opaque memory address range</p> <p>1: Enable opaque memory address range</p>
P_CFG_BUSY	C6	I	<p><b>Primary Configuration Busy:</b> Determines the value of bit [2] offset 44h to sequence initialization on the primary and secondary buses for applications that require bridge configuration from the secondary bus. Applications that do not require configuration from the secondary bus should pull this pin down to ground.</p> <p>0: Type 0 configuration commands accepted normally on the primary bus.</p> <p>1: Type 0 configuration commands are retried on the primary bus.</p>
RESERVED	D1	-	<b>Reserved.</b> Must be tied to ground.

### 3.2.7 JTAG BOUNDARY SCAN AND TEST SIGNALS

Name	Pin #	Type	Description
TCK	F21	IU	<b>Test Clock.</b> Used to clock state information and data into and out of the PI721P100 during boundary scan.
TMS	D22	IU	<b>Test Mode Select.</b> Used to control the state of the Test Access Port controller.
TDO	B23	O	<b>Test Data Output.</b> Used as the serial output for the test instructions and data from the test logic.
TDI	C22	IU	<b>Test Data Input.</b> Serial input for the JTAG instructions and test data.
TRST#	C23	IU	<b>Test Reset.</b> Active LOW signal to reset the Test Access Port (TAP) controller into an initialized state.

### 3.2.8 TEST SIGNALS

Name	Pin #	Type	Description												
T_DI1	Y21	IU	<p><b>PLL Bypass Control for PCI-X Mode.</b> The strapped value of this pin (at P_RST# deassertion) controls whether the internal PLL's are bypassed in PCI-X mode.</p> <p>HIGH: PLL's are used in PCI-X mode</p> <p>LOW: PLL's are bypassed in PCI-X mode</p>												
T_DI2	AA4	IU	<p><b>Shorten Initialization Period.</b> Controls the period for the following signals during initialization.</p> <p>LOW: Shorten periods</p> <p>T<sub>PIRSTDLY</sub> - 5 Primary Clocks  T<sub>XCAP</sub> - 6 Primary Clocks  T<sub>SIRSTDLY</sub> - 40 Secondary Clocks  T<sub>SRSTDLY</sub> - 11 Secondary Clocks + 7 Primary Clocks</p> <p>HIGH: Normal initialization</p> <p>T<sub>FIRSTDLY</sub> - See Table 7-2  T<sub>XCAP</sub> - See Table 7-2  T<sub>SIRSTDLY</sub> - See Table 7-2  T<sub>SRSTDLY</sub> - See Table 7-2</p>												
T_MODECTL T_RI XCLK_OUT	C1 W22 D3	I I I	<p><b>PLL Test Control.</b> Controls along with the internal PLL testing.</p> <table border="1" style="margin-left: auto; margin-right: auto;"> <thead> <tr> <th>T_RI</th> <th>T_MODECTL</th> <th>XCLK_OUT</th> </tr> </thead> <tbody> <tr> <td>H</td> <td>L</td> <td>Z</td> </tr> <tr> <td>H</td> <td>H</td> <td>P_CLK*</td> </tr> <tr> <td>L</td> <td>H</td> <td>S_CLK**</td> </tr> </tbody> </table> <p>* P_PLL enabled, S_PLL disabled  **P_PLL disabled, S_PLL enabled</p>	T_RI	T_MODECTL	XCLK_OUT	H	L	Z	H	H	P_CLK*	L	H	S_CLK**
T_RI	T_MODECTL	XCLK_OUT													
H	L	Z													
H	H	P_CLK*													
L	H	S_CLK**													
T_RI	W22	I	<p><b>PLL Bypass Control for PCI Mode.</b> The strapped value of this pin (at T_RI) controls whether the internal PLL's are bypassed in PCI mode.</p> <p>1: PLL's are bypassed in PCI mode</p> <p>0 and T_MODECTL=0: PLL's are used in PCI mode</p>												
TEST_CE0	Y23	ID	<p><b>Reserved.</b> Chip testing only. Tie LOW for normal operation.</p>												

### 3.2.9 POWER AND GROUND SIGNALS

Name	Pin #	Type	Description
P_VDDA	A21	P	<b>2.5V Power:</b> Power supply to the PLL for the primary clock domain.
P_VSSA	D16	P	<b>2.5V Power:</b> Ground for the PLL for the primary clock domain.
S_VDDA	AB21	P	<b>2.5V Power:</b> Power supply to the PLL for the secondary clock domain.
S_VSSA	Y16	P	<b>2.5V Power:</b> Ground for the PLL for the secondary clock domain.
VDD	D9, D11, D13, D15, J4, J20, L4, L20, N4, N20, R4, R20, Y9, Y11, Y13, Y15	P	<b>2.5 Power:</b> Power supply for the internal logic

Name	Pin #	Type	Description
VDD2	A8, A12, A22, C5, D5, D7, D17, D19, E4, E20, G4, G20, H23, M1, T1, U4, U20, W4, W20, Y5, Y7, Y17, Y19, AC2, AC12, AC16	P	<b>3.3 Power:</b> Power supply for the I/O
VSS	A1, A6, A10, A11, A14, A18, A23, B2, B22, C3, C21, D4, D8, D12, D20, F1, F23, H4, H20, K1, K23, L23, M4, M20, N1, P1, P23, T4, T20, V1, V23, Y4, Y8, Y12, Y20, AA3, AA21, AB2, AB22, AC1, AC6, AC10, AC13, AC14, AC18, AC23	P	<b>Ground</b>

### 3.3 PIN LIST

**Table 3-1 PIN LIST 304-PIN PBGA**

BALL LOCATION	PIN NAME	TYPE	BALL LOCATION	PIN NAME	TYPE
A1	VSS	P	A2	P ACK64#	STS
A3	P AD[56]	TS	A4	P AD[60]	TS
A5	P CBE[4]#	TS	A6	VSS	P
A7	P CBE[7]#	TS	A8	VDD2	P
A9	P PAR64	TS	A10	VSS	P
A11	VSS	P	A12	VDD2	P
A13	P CBE[0]#	TS	A14	VSS	P
A15	P CBE[3]#	TS	A16	P IRDY#	STS
A17	P FRAME#	STS	A18	VSS	P
A19	P AD[4]	TS	A20	P AD[7]	TS
A21	P VDDA	P	A22	VDD2	P
A23	VSS	P	B1	P AD[43]	TS
B2	VSS	P	B3	P AD[54]	TS
B4	P SERR#	OD	B5	P AD[49]	TS
B6	P AD[50]	TS	B7	P AD[52]	TS
B8	P AD[55]	TS	B9	P AD[57]	TS
B10	P AD[59]	TS	B11	P AD[63]	TS
B12	P CBE[6]#	TS	B13	P AD[0]	TS
B14	P AD[2]	TS	B15	P TRDY#	STS
B16	P AD[5]	TS	B17	P AD[8]	TS
B18	P CBE[1]#	TS	B19	P IDSEL	I
B20	P AD[15]	TS	B21	P REQ#	TS
B22	VSS	P	B23	TDO	O
C1	T MODECTL	I	C2	P AD[48]	TS
C3	VSS	P	C4	P STOP#	STS
C5	VDD2	P	C6	P CFG BUSY	I
C7	P AD[53]	TS	C8	P PERR#	STS
C9	P AD[58]	TS	C10	P AD[61]	TS
C11	P CBE[5]#	TS	C12	P REQ64#	STS
C13	P AD[1]	TS	C14	P LOCK#	I
C15	P AD[3]	TS	C16	P AD[6]	TS
C17	P AD[9]	TS	C18	P PAR	TS
C19	P AD[10]	TS	C20	P GNT#	I
C21	VSS	P	C22	TDI	I
C23	TRST#	I	D1	RESERVED	-

BALL LOCATION	PIN NAME	TYPE	BALL LOCATION	PIN NAME	TYPE
D2	P_AD[47]	TS	D3	XCLK_OUT	I
D4	VSS	P	D5	VDD2	P
D6	P_AD[51]	TS	D7	VDD2	P
D8	VSS	P	D9	VDD	P
D10	P_AD[62]	TS	D11	VDD	P
D12	VSS	P	D13	VDD	P
D14	P_CBE[2]#	TS	D15	VDD	P
D16	P_VSSA	P	D17	VDD2	P
D18	P_AD[11]	TS	D19	VDD2	P
D20	VSS	P	D21	P_DEVSEL#	STS
D22	TMS	I	D23	P_AD[22]	TS
E1	P_AD[38]	TS	E2	P_DRVVER	I
E3	P_AD[45]	TS	E4	VDD2	P
E20	VDD2	P	E21	P_CLK	I
E22	P_RST#	I	E23	P_AD[24]	TS
F1	VSS	P	F2	P_AD[42]	TS
F3	P_AD[44]	TS	F4	P_AD[46]	TS
F20	P_AD[13]	TS	F21	TCK	I
F22	P_AD[12]	TS	F23	VSS	P
G1	P_AD[36]	TS	G2	BAR_EN	I
G3	P_AD[41]	TS	G4	VDD2	P
G20	VDD2	P	G21	P_AD[16]	TS
G22	P_AD[14]	TS	G23	P_AD[26]	TS
H1	P_AD[35]	TS	H2	P_AD[39]	TS
H3	P_AD[40]	TS	H4	VSS	P
H20	VSS	P	H21	P_AD[18]	TS
H22	P_AD[17]	TS	H23	VDD2	P
J1	P_AD[33]	TS	J2	P_AD[34]	TS
J3	P_AD[37]	TS	J4	VDD	P
J20	VDD	P	J21	P_AD[20]	TS
J22	P_AD[19]	TS	J23	P_AD[31]	TS
K1	VSS	P	K2	S_AD[34]	TS
K3	S_AD[33]	TS	K4	S_AD[32]	TS
K20	P_AD[25]	TS	K21	P_AD[23]	TS
K22	P_AD[21]	TS	K223	VSS	P
L1	P_AD[32]	TS	L2	S_AD[36]	TS
L3	S_AD[35]	TS	L4	VDD	P
L20	VDD	P	L21	P_AD[28]	TS
L22	P_AD[27]	TS	L23	VSS	P
M1	VDD2	P	M2	S_AD[39]	TS
M3	S_AD[38]	TS	M4	VSS	P
M20	VSS	P	M21	P_AD[30]	TS
M22	P_AD[29]	TS	M23	S_AD[27]	TS
N1	VSS	P	N2	S_AD[41]	TS
N3	S_AD[40]	TS	N4	VDD	P
N20	VDD	P	N21	S_AD[30]	TS
N22	S_AD[31]	TS	N23	S_AD[25]	TS
P1	VSS	P	P2	S_AD[47]	TS
P3	S_AD[45]	TS	P4	S_AD[43]	TS
P20	S_AD[26]	TS	P21	S_AD[28]	TS
P22	S_AD[29]	TS	P23	VSS	P
R1	S_AD[37]	TS	R2	S_AD[49]	TS
R3	S_AD[48]	TS	R4	VDD	P
R20	VDD	P	R21	S_AD[22]	TS
R22	S_AD[24]	TS	R23	S_PCIXCAP	I
T1	VDD2	P	T2	S_AD[51]	TS
T3	S_AD[50]	TS	T4	VSS	P
T20	VSS	P	T21	S_ARB#	I
T22	S_AD[20]	TS	T23	S_AD[23]	TS
U1	S_AD[42]	TS	U2	S_AD[53]	TS
U3	S_AD[52]	TS	U4	VDD2	P
U20	VDD2	P	U21	S_AD[18]	TS
U22	S_AD[19]	TS	U23	S_RST#	O

BALL LOCATION	PIN NAME	TYPE	BALL LOCATION	PIN NAME	TYPE
V1	VSS	P	V2	S_AD[55]	TS
V3	S_SEL100	I	V4	S_AD[54]	TS
V20	S_AD[14]	TS	V21	S_AD[16]	TS
V22	S_AD[17]	TS	V23	VSS	P
W1	S_AD[44]	TS	W2	S_REQ[3]#	I
W3	S_CLK_STABLE	I	W4	VDD2	P
W20	VDD2	P	W21	S_AD[15]	TS
W22	T_RI	I	W23	S_AD[21]	TS
Y1	S_AD[46]	TS	Y2	S_GNT[3]#	TS
Y3	S_AD[56]	TS	Y4	VSS	P
Y5	VDD2	P	Y6	S_AD[57]	TS
Y7	VDD2	P	Y8	VSS	P
Y9	VDD	P	Y10	S_CBE[7]#	TS
Y11	VDD	P	Y12	VSS	P
Y13	VDD	P	Y14	S_TRDY#	STS
Y15	VDD	P	Y16	S_VSSA	P
Y17	VDD2	P	Y18	S_AD[11]	TS
Y19	VDD2	P	Y20	VSS	P
Y21	T_DI1	I	Y22	64BIT_DEV#	I
Y23	TEST_CE0	I	AA1	S_PCIXCAP_PU	I
AA2	S_REQ[2]#	I	AA3	VSS	P
AA4	T_DI2	I	AA5	S_AD[58]	TS
AA6	S_AD[59]	TS	AA7	S_AD[61]	TS
AA8	S_ACK64#	STS	AA9	S_AD[0]	TS
AA10	S_PAR64	TS	AA11	S_CBE[5]#	TS
AA12	S_AD[6]	TS	AA13	S_AD[7]	TS
AA14	S_FRAME#	STS	AA15	S_CBE[3]#	TS
AA16	S_AD[10]	TS	AA17	S_PAR	TS
AA18	OPAQUE_EN	I	AA19	S_GNT[1]#	TS
AA20	S_AD[13]	TS	AA21	VSS	P
AA22	S_IDSEL	I	AA23	S_REQ[1]#	I
AB1	S_GNT[2]#	TS	AB2	VSS	P
AB3	S_REQ[4]#	I	AB4	S_GNT[5]#	TS
AB5	S_REQ[5]#	I	AB6	S_AD[60]	TS
AB7	S_AD[62]	TS	AB8	S_AD[63]	TS
AB9	S_AD[1]	TS	AB10	S_CBE[6]#	TS
AB11	S_AD[4]	TS	AB12	S_CBE[0]#	TS
AB13	S_REQ64#	STS	AB14	S_CBE[2]#	TS
AB15	S_AD[9]	TS	AB16	S_CBE[1]#	TS
AB17	S_PERR#	STS	AB18	S_AD[12]	TS
AB19	S_SERR#	I	AB20	S_STOP#	STS
AB21	S_VDDA	P	AB22	VSS	P
AB23	S_CLK	I	AC1	VSS	P
AC2	VDD2	P	AC3	S_REQ[6]#	I
AC4	S_GNT[6]#	TS	AC5	S_GNT[4]#	TS
AC6	VSS	P	AC7	S_DRVR	I
AC8	S_CBE[4]#	TS	AC9	S_AD[2]	TS
AC10	VSS	P	AC11	S_AD[3]	TS
AC12	VDD2	P	AC13	VSS	P
AC14	VSS	P	AC15	S_AD[5]	TS
AC16	VDD2	P	AC17	S_AD[8]	TS
AC18	VSS	P	AC19	S_IRDY#	STS
AC20	S_LOCK#	STS	AC21	S_DEVSEL#	STS
AC22	IDSEL_ROUTE	I	AC23	VSS	P

## 4 PCI BUS OPERATION

This Chapter offers information about PCI transactions, transaction forwarding across PI7C21P100, and transaction termination. The PI7C21P100 has two 2KB buffers for read data buffering of upstream and downstream transactions. Also, PI7C21P100 has two 1KB buffers for write data buffering of upstream and downstream transactions.

### 4.1 TYPES OF TRANSACTIONS

This section provides a summary of PCI and PCI-X transactions performed by PI7C21P100. Table 4-1 lists the command code and name of each PCI and PCI-X transaction. The Master and Target columns indicate support for each transaction when PI7C21P100 initiates transactions as a master, on the primary and secondary buses, and when PI7C21P100 responds to transactions as a target, on the primary and secondary buses.

**Table 4-1 PCI AND PCI-X TRANSACTIONS**

Types of Transactions		Initiates as Master		Responds as Target	
		Primary	Secondary	Primary	Secondary
0000	Interrupt Acknowledge	N	N	N	N
0001	Special Cycle	Y	Y	N	N
0010	I/O Read	Y	Y	Y	Y
0011	I/O Write	Y	Y	Y	Y
0100	Reserved	N	N	N	N
0101	Reserved	N	N	N	N
0110	Memory Read	Y	Y	Y	Y
0111	Memory Write	Y	Y	Y	Y
1000	Reserved	N	N	N	N
1001	Reserved	N	N	N	N
1010	Configuration Read	N	Y	Y	Y (Type 0 only)
1011	Configuration Write	Y (Type 1 only)	Y	Y	Y
1100	Memory Read Multiple	Y	Y	Y	Y
1101	Dual Address Cycle	Y	Y	Y	Y
1110	Memory Read Line	Y	Y	Y	Y
1111	Memory Write and Invalidate	Y	Y	Y	Y

As indicated in Table 4-1, the following commands are not supported by PI7C21P100:

- PI7C21P100 never initiates a transaction with a reserved command code and, as a target, PI7C21P100 ignores reserved command codes.
- PI7C21P100 does not generate interrupt acknowledge transactions. PI7C21P100 ignores interrupt acknowledge transactions as a target.
- PI7C21P100 does not respond to special cycle transactions. PI7C21P100 cannot guarantee delivery of a special cycle transaction to downstream buses because of the broadcast nature of the special cycle command and the inability to control the transaction as a target. To generate special cycle transactions on other buses, either upstream or downstream, Type 1 configuration write must be used.

## 4.2 WRITE TRANSACTIONS

Write transactions are treated as posted write, delayed/split (PCI-X), or immediate write transactions. Table 4-2 shows the method of forwarding used for each type of write operation.

**Table 4-2 WRITE TRANSACTION FORWARDING**

Type of Transaction	Type of Forwarding
Memory Write	Posted
Memory Write and Invalidate	Posted
Memory Write Block (PCI-X)	Posted
I/O Write	Delayed / Split (PCI-X)
Type 0 Configuration Write	Immediate on the primary bus. Delayed / Split (PCI-X) on the secondary bus.
Type 1 Configuration Write	Delayed / Split (PCI-X)

### 4.2.1 MEMORY WRITE TRANSACTIONS

Posted write forwarding is used for “Memory Write”, “Memory Write and Invalidate”, and “Memory Write Block” transactions.

When PI7C21P100 determines that a memory write transaction is to be forwarded across the bridge, PI7C21P100 asserts DEVSEL# with medium decode timing and TRDY# in the next cycle, provided that enough buffer space is available in the posted memory write queue for the address and at least one DWORD of data. Under this condition, PI7C21P100 accepts write data without obtaining access to the target bus. The PI7C21P100 can accept one DWORD of write data every PCI clock cycle. That is, no target wait state is inserted. The write data is stored in an internal posted write buffers and is subsequently delivered to the target. The PI7C21P100 continues to accept write data until one of the following events occurs:

- The initiator terminates the transaction by de-asserting FRAME# and IRDY#.
- An internal write address boundary is reached, such as a cache line boundary or an aligned 4KB boundary, depending on the transaction type.
- The posted write data buffer fills up.

When one of the last two events occurs, the PI7C21P100 returns a target disconnect to the requesting initiator on this data phase to terminate the transaction.

Once the posted write data moves to the head of the posted data queue, PI7C21P100 asserts its request on the target bus. This can occur while PI7C21P100 is still receiving data on the initiator bus. When the grant for the target bus is received and the target bus is detected in the idle condition, PI7C21P100 asserts FRAME# and drives the stored write address out on the target bus. On the following cycle, PI7C21P100 drives the first DWORD of write data and continues to transfer write data until all write data corresponding to that transaction is delivered, or until a target termination is received. As long as write data exists in the queue, PI7C21P100 can drive one DWORD of write data in each PCI clock cycle; that is, no master wait states are inserted. If write data is flowing through PI7C21P100 and the initiator stalls, PI7C21P100 will signal the last data phase for the current transaction at the target bus if the queue empties. PI7C21P100 will restart the follow-on transactions if the queue has new data.

PI7C21P100 ends the transaction on the target bus when one of the following conditions is met:

- All posted write data has been delivered to the target.
- The target returns a target disconnect or target retry (PI7C21P100 starts another transaction to deliver the rest of the write data).
- The target returns a target abort (PI7C21P100 discards remaining write data).
- The master latency timer expires, and PI7C21P100 no longer has the target bus grant (PI7C21P100 starts another transaction to deliver remaining write data).

#### **4.2.1.1 PCI-X TO PCI-X**

When both buses are operating in the PCI-X mode, PI7C21P100 passes the memory write command that it receives to the destination interface along with the originating byte count and transaction ID. PI7C21P100 attempts to transfer a memory write command when the transaction ends or a 128-byte boundary is crossed. As long as there is at least 128-byte of data in the data buffer or the end of transfer remains from the PCI-X memory write command when a 128-byte boundary is crossed, the transfer will continue. If a transaction is disconnected on the destination interface in the middle of a continuing transfer, the byte count and address are updated and the transaction is presented again on the destination interface. If a transaction is disconnected in the middle of a continuing transfer on the originating interface, the originator must present the transaction again with the updated byte count and address.

#### **4.2.1.2 PCI TO PCI**

When both buses are operating in conventional PCI mode, the bridge passes the memory write command that it receives to the destination interface, unless PI7C21P100 is disconnected in the middle of a memory write and invalidate and is not on a cache line boundary. If this happens, the command will continue as a memory write when PI7C21P100 attempts to reconnect. PI7C21P100 attempts to transfer a memory write command when the transaction ends or a 128-byte boundary is crossed. As long as a 128-byte buffer is full or the end of transfer remains from the memory write command when a 128-byte boundary is crossed, the transfer will continue.

#### **4.2.1.3 PCI TO PCI-X**

When the originating bus is operating in the conventional PCI mode and the destination bus is operating in the PCI-X mode, PI7C21P100 must buffer memory write transactions from the conventional PCI interface and count the number of bytes to be forwarded to the PCI-X interface. If the conventional PCI transaction uses the memory write command and some byte enables are not asserted, PI7C21P100 must use the PCI-X memory write command. If the conventional PCI command is memory write and all byte enables are asserted, PI7C21P100 will use the PCI-X memory write command. If the conventional transaction uses the memory write and invalidate command, PI7C21P100 uses the PCI-X memory write block command. PI7C21P100 attempts to transfer the write data on the PCI-X interface as soon as the transaction ends or a 128-byte boundary is crossed. Writes greater than 128 bytes are possible only if more than one 128-byte sector fills up before the write operation is issued on the PCI-X interface.



**4.2.1.4 PCI-X TO PCI**

When the originating bus is operating in the PCI-X mode and the destination bus is operating in the conventional PCI mode, PI7C21P100 uses the PCI conventional memory write command for both the PCI-X memory write and PCI-X memory write block commands. PI7C21P100 attempts to transfer write data on the conventional PCI interface when the PCI-X data crosses a 128-byte boundary or the end of the PCI-X transfer occurs. As long as a 128-byte buffer is full, or the end of transfer remains from the PCI-X memory write command when a 128-byte boundary is crossed, the transfer will continue on the conventional PCI interface.

**4.2.2 DELAYED/SPLIT WRITE TRANSACTIONS**

Delayed/Split write forwarding is used for I/O write transactions, Type 1 configuration write transactions, and Type 0 configuration write transactions.

Delayed/Split write forwarding transactions are retried on the originating bus, completed on the destination bus (if necessary), and then completed on the originating bus. For DWORD transactions, PI7C21P100 uses delayed transactions in conventional PCI mode and split requests in PCI-X mode. Only one request queue entry is allowed for either delayed or split write transactions.

**4.2.3 IMMEDIATE WRITE TRANSACTIONS**

PI7C21P100 considers Type 0 configuration writes on the primary bus meant for the bridge as immediate write transactions for the bridge. PI7C21P100 will execute the transaction and indicate its completion by accepting the DWORD of data immediately.

**4.3 READ TRANSACTIONS**

Read transactions are treated as delayed read for conventional PCI mode, split read for PCI-X mode, or immediate read. Table 4-3 shows the read behavior.

**Table 4-3 READ TRANSACTIONS HANDLING**

Type of Transaction	Type of Handling
Memory Read	Delayed
Memory Read Line	Delayed
Memory Read Multiple	Delayed
Memory Read DWORD (PCI-X mode)	Split (PCI-X mode)
Memory Read Block (PCI-X mode)	Split (PCI-X mode)
I/O Read	Delayed/Split (PCI-X)
Type 0 Configuration Read	Immediate on the primary bus, Delayed/Split (PCI-X mode) on the secondary bus
Type 1 Configuration Read	Delayed/Split (PCI-X mode)

### **4.3.1 MEMORY READ TRANSACTIONS**

Memory data is transferred from the originating side of PI7C21P100 to the destination side using PCI memory read, memory read line, memory read multiple, PCI-X memory read DWORD, and PCI-X memory read block transactions. All memory read transactions are either delayed or split on the originating side of PI7C21P100 depending on the mode of the originating side.

#### **4.3.1.1 PCI-X TO PCI-X**

No translation is needed for these transactions.

The amount of data that is fetched is controlled by the downstream and upstream split transaction control register. The split transaction capacity and split transaction commitment limit fields control how much data is requested at any one time.

#### **4.3.1.2 PCI TO PCI**

No translation is needed for these transactions.

Memory Read – Fetches only the requested DWORD if the command targets a non-prefetchable memory space. Bits [25:24] offset 40h and bits [9:8] offset 40h control the mode of prefetching for memory read transactions in the prefetchable range on the secondary and primary bus respectively. The default is up to one cache line will be prefetched.

Memory Read Line – Bits [23:22] offset 40h and bits [7:6] offset 40h control the mode of prefetching for memory read line transactions in the prefetchable range on the secondary and primary bus respectively. The default is up to one cache line will be prefetched.

Memory Read Multiple – Bits [21:20] offset 40h and bits [5:4] offset 40h control the mode of prefetching for memory read multiple transactions in the prefetchable range on the secondary and primary bus respectively. The default is a full prefetch, limited to the value set by bits [14:12] offset 40h. The default value is 512 bytes, or an entire read buffer.

#### **4.3.1.3 PCI TO PCI-X**

PI7C21P100 must translate the conventional PCI memory read command to either the memory read DWORD or the memory read block PCI-X Command. If the conventional PCI memory read command targets non-prefetchable memory space, the command is translated into a memory read DWORD. In any other instance, the conventional PCI memory read command gets translated into a memory read block PCI-X command. Bits [25:24] offset 40h and bits [9:8] offset 40h control the mode of prefetching for memory read transactions in the prefetchable range on the secondary and primary bus respectively. The default is up to one cache line will be prefetched. The default is up to one cache line will be prefetched.

PI7C21P100 translates the conventional PCI memory read line command to the memory read block PCI-X command. Bits [23:22] offset 40h and bits [7:6] offset 40h control the mode of prefetching for memory read line transactions in the prefetchable range on the secondary and primary bus respectively. The default is up to one cache line will be prefetched.

PI7C21P100 must translate the conventional PCI memory read multiple command to the memory read block PCI-X command. Bits [21:20] offset 40h and bits [5:4] offset 40h control the mode of prefetching for memory read multiple transactions in the prefetchable range on the secondary and primary bus respectively. The default is a full prefetch, limited to the value set by bits [14:12] offset 40h. The default value is 512 bytes, or an entire read buffer. Using a value greater than this is possible, but it may be constrained by the setting of the split transaction commitment limit value in the upstream or downstream split transaction register, since the target bus is in PCI-X mode. Data fetching operations will be disconnected at all 1MB boundaries.

#### **4.3.1.4 PCI-X TO PCI**

PI7C21P100 translates PCI-X memory read DWORD commands into conventional PCI memory read commands. PI7C21P100 translates a PCI-X memory read block command into one of three conventional PCI memory read commands based on the byte count and starting address. If the starting address and byte count are such that only a single DWORD (or less) is being read, the conventional PCI transaction uses the memory read command. If the PCI-X transaction reads more than one DWORD, but does not cross a cache line boundary (indicated by the Cache Line Size register in the conventional Configuration Space header), the conventional transaction uses the memory read line command. If the PCI-X transaction crosses a cache line boundary, the conventional transaction uses the memory read multiple command. If a disconnect occurs before the byte count of the PCI-X memory read block command is exhausted, the PI7C21P100 continues to issue the command until all the bytes in the count are received. PI7C21P100 disconnects once the buffer is filled and prefetches more data as 128-byte sectors of the buffer become free when split completion data is returned to the originator, until the byte count is exhausted.

#### **4.3.2 I/O READ**

The I/O Read command is not translated and fetches a DWORD of data. The command will either be split in the PCI-X mode or delayed in the conventional PCI mode.

#### **4.3.3 CONFIGURATION READ**

##### **4.3.3.1 TYPE 1 CONFIGURATION READ**

The Type 1 configuration read command is only accepted on the primary interface. The command will either be split in the PCI-X mode or delayed in the conventional PCI mode.

##### **4.3.3.2 TYPE 0 CONFIGURATION READ**

The Type 0 configuration read command is accepted on either the primary or secondary interface. The command returns immediate data on the primary interface regardless of the interface mode. On the secondary interface the command is treated either as a split transaction in PCI-X mode or as a delayed transaction in the PCI mode.

#### **4.3.4 NON-PREFETCHABLE AND DWORD READS**

A non-prefetchable read transaction is a read transaction in which PI7C21P100 requests exactly one DWORD from the target and disconnects the initiator after delivering that one DWORD of read data. Unlike prefetchable read transactions, PI7C21P100 forwards the read byte enable information for the data phase. Non-prefetchable behavior is used for I/O, configuration, memory read transactions that fall into the nonprefetchable memory space for PCI mode, and all DWORD read transactions in PCI-X mode.

#### **4.3.5 PREFETCHABLE READS**

A prefetchable read transaction is a read transaction where PI7C21P100 performs speculative reads, transferring data from the target before it is requested from the initiator. This behavior allows a prefetchable read transaction to consist of multiple data transfers. For prefetchable read transactions, all byte enables are asserted for all data phases.

Prefetchable behavior is used for memory read line and memory read multiple transactions, as well as for memory read transactions that fall into prefetchable memory space and are allowed to fetch more than a DWORD. The amount of data that is prefetched depends on the type of transaction and the setting of bits in the primary and secondary data buffering control registers in configuration space. The amount of prefetching may also be affected by the amount of free buffer space available in PI7C21P100, and by any read address boundaries encountered.

##### **4.3.5.1 PCI-X TO PCI-X AND PCI-X TO PCI**

For PCI-X to PCI transactions, PI7C21P100 continues to generate data requests to the PCI interface and keeps the prefetch buffer full until the entire amount of data requested is transferred.

For PCI-X to PCI-X transactions, the split transaction commitment limit value contained in the upstream or downstream split transaction register determines the operation. If the value is greater than or equal to the split transaction capacity (4KB) but less than 32KB, the maximum request amount is 512 bytes. Larger transfers will be decomposed into a series of smaller transfers, until the original byte count has been satisfied. If the commitment limit value indicates 32KB or more, the original request amount is used and decomposition is not performed.

If the original request is broken into smaller requests the bridge waits until the previous completion has been totally received before a new request is issued. This ensures that the data does not get out of order and that two requests with the same sequence ID are not issued. In either case, the bridge generates a new requester ID for each request passed through the bridge.

##### **4.3.5.2 PCI TO PCI**

The method used for transfers in PCI-to-PCI mode is user defined in the primary and secondary data buffering control registers. These registers have bits for memory read to prefetchable space, memory read line, and memory read multiple transactions. For memory read, the bits select whether to read a DWORD, read to a cache line boundary, or to fill the prefetch buffer. For memory read line and memory read multiple transactions, the bits select whether to read to a cache line boundary or to fill the prefetch buffer. In all cases, if the bits

are selected to fill the prefetch buffer, the maximum amount of data that is requested on the target interface is controllable by the setting of the maximum memory read byte count bits of the Primary and Secondary Data Buffering Control registers. When more than 512 bytes are requested, the bridge fetches data to fill the buffer and then fetches more data to keep the buffer filled as sectors (128 bytes) are emptied and become free to use again.

#### **4.3.5.3 PCI TO PCI-X**

The method used for transfers in the PCI to PCI-X mode is similar to transfers in the PCI-to-PCI mode, except that the maximum request amount may be additionally constrained by the setting of the split transaction commitment limit value in the upstream or downstream split transaction register. The only other difference is that prefetching will not stop when the originating master disconnects. Prefetching will only stop when all of the requested data is received.

#### **4.3.6 DYNAMIC PREFETCH (CONVENTIONAL PCI MODE ONLY)**

For prefetchable reads described in the previous section, the prefetching length is normally predefined and cannot be changed once it is set. This may cause some inefficiency as the prefetching length determined could be larger or smaller than the actual data being prefetched. To make prefetching more efficient, PI7C21P100 incorporates dynamic prefetching control logic. This logic regulates the different PCI memory read commands (MR – memory read, MRL – memory read line, and MRM – memory read multiple) to improve memory read burst performance. PI7C21P100 tracks every memory read burst transaction and tallies the status. By using the status information, PI7C21P100 can determine to increase, reduce, or keep the same cache line length to be prefetched. Over time, PI7C21P100 can better match the correct cache line setting to the length of data being requested. The dynamic prefetching control logic is set with bits[3:2] offset 48h.

### **4.4 CONFIGURATION TRANSACTIONS**

Configuration transactions are used to initialize a PCI system. Every PCI device has a configuration space that is accessed by configuration commands. All registers are accessible in configuration space only.

In addition to accepting configuration transactions for initialization of its own configuration space, the PI7C21P100 also forwards configuration transactions for device initialization in hierarchical PCI systems, as well as for special cycle generation.

To support hierarchical PCI bus systems, two types of configuration transactions are specified: Type 0 and Type 1.

Type 0 configuration transactions are issued when the intended target resides on the same PCI bus as the initiator. A Type 0 configuration transaction is identified by the configuration command and the lowest two bits of the address set to 00b.

Type 1 configuration transactions are issued when the intended target resides on another PCI bus, or when a special cycle is to be generated on another PCI bus. A Type 1 configuration command is identified by the configuration command and the lowest two address bits set to 01b.

The register number is found in both Type 0 and Type 1 formats and gives the DWORD address of the configuration register to be accessed. The function number is also included in both Type 0 and Type 1 formats and indicates which function of a multifunction device is to be accessed. For single-function devices, this value is not decoded. The addresses of Type 1 configuration transactions include a 5-bit field designating the device number that identifies the device on the target PCI bus that is to be accessed. In addition, the bus number in Type 1 transactions specifies the PCI bus to which the transaction is targeted.

#### **4.4.1 TYPE 0 ACCESS TO PI7C21P100**

The configuration space is accessed by a Type 0 configuration transaction. The configuration space can be accessed from the primary or secondary interface. S\_IDSEL should be tied LOW if access is not required from the secondary interface.

On the primary interface, PI7C21P100 responds to a Type 0 configuration transaction by accepting the transaction when the following conditions are met during the address phase:

- P\_CBE[3:0]# indicates a configuration write or configuration read transaction
- The two lowest address bits on P\_AD[1:0] are 00
- P\_IDSEL is asserted
- Bit[2] offset 44h (Miscellaneous Control Register) is 0

On the secondary interface, PI7C21P100 responds to a Type 0 configuration transaction by accepting the transaction when the following conditions are met during the address phase:

- S\_CBE[3:0]# indicates a configuration write or configuration read transaction
- The two lowest address bits on S\_AD[1:0] are 00
- S\_IDSEL is asserted

The function number is not decoded since the bridge is a single-function device. All configuration transactions to the bridge are handled as DWORD operations.

#### **4.4.2 TYPE 1 TO TYPE 0 CONVERSION**

Type 1 configuration transactions are used specifically for device configuration in a hierarchical PCI/PCI-X bus system. A bridge is the only type of device that should respond to a Type 1 configuration command. Type 1 configuration commands are used when the configuration access is intended for a PCI/PCI-X device that resides on a bus other than the one where the Type 1 transaction is generated.

PI7C21P100 performs a Type 1 to Type 0 translation when the Type 1 transaction is generated on the primary interface and is intended for a device attached directly to the secondary interface. PI7C21P100 must convert the configuration command to a Type 0 format so that the secondary bus device can respond to it. Type 1 to Type 0 translations are performed only in the downstream direction.

PI7C21P100 responds to a Type 1 configuration transaction and translates it into a Type 0 transaction on the secondary interface when the following conditions are met during the address phase:

- The lowest two address bits on P\_AD[1:0] are 01b.

- The bus number in address field P\_AD[23:16] is equal to the value in the secondary bus number register in configuration space.
- P\_CBE[3:0]# is a configuration read or configuration write transaction.

When PI7C21P100 translates the Type 1 transaction to a Type 0 transaction on the secondary interface, it performs the following translations to the address:

- Sets the lowest two address bits on S\_AD[1:0] to 00.
- Decodes the device number and drives the bit pattern specified in Table 4-4 on S\_AD[31:16] for the purpose of asserting the device's IDSEL signal.
- Sets S\_AD[15:11] to 0 if the secondary bus is operating in conventional PCI mode (device number is passed through unchanged in PCI-X mode)
- Leaves unchanged the function number and register number fields.

PI7C21P100 asserts a unique address line based on the device number. These address lines may be used as secondary bus IDSEL signals. The mapping of the address lines depends on the device number in the address bits P\_AD[15:11] for Type 1 transactions. Table 4-4 presents the mapping that PI7C21P100 uses.

**Table 4-4 DEVICE NUMBER TO IDSEL**

Device Number	P_AD[15:11]	Secondary IDSEL S_AD[31:16]
0h	00000	0000 0000 0000 0001
1h	00001	0000 0000 0000 0010
2h	00010	0000 0000 0000 0100
3h	00011	0000 0000 0000 1000
4h	00100	0000 0000 0001 0000
5h	00101	0000 0000 0010 0000
6h	00110	0000 0000 0100 0000
7h	00111	0000 0000 1000 0000
8h	01000	0000 0001 0000 0000
9h	01001	0000 0010 0000 0000
Ah	01010	0000 0100 0000 0000
Bh	01011	0000 1000 0000 0000
Ch	01100	0001 0000 0000 0000
Dh	01101	0010 0000 0000 0000
Eh	01110	0100 0000 0000 0000
Fh	01111	1000 0000 0000 0000
10h – 1Eh	10000 – 11110	0000 0000 0000 0000
1Fh	11111	0000 0000 0000 0000 or, may convert to a special cycle transaction described in section 4.4.4

PI7C21P100 forwards Type 1 to Type 0 configuration read or write transactions as delayed transactions in PCI mode or as split transactions in PCI-X mode.

### 4.4.3 TYPE 1 TO TYPE 1 FORWARDING

Type 1 to Type 1 transaction forwarding provides a hierarchical configuration mechanism when two or more levels of PCI-to-PCI bridges are used.

When PI7C21P100 detects a Type 1 configuration transaction intended for a PCI/PCI-X bus downstream from the secondary interface, PI7C21P100 forwards the transaction unchanged to the secondary interface. Ultimately, this transaction is translated to a Type 0 configuration command or to a special cycle transaction by a downstream PCI bridge. Downstream Type 1 to Type 1 forwarding occurs when the following conditions are met during the address phase:

- The lowest two address bits on P\_AD[1:0] are equal to 01b.
- The bus number falls in the range defined by the lower limit (exclusive) in the secondary bus number register and the upper limit (inclusive) in the subordinate bus number register.
- P\_AD[1:0] is a configuration read or configuration write transaction.

PI7C21P100 also supports Type 1 to Type 1 forwarding of configuration write transactions upstream to support upstream special cycle generation. All upstream Type 1 configuration read commands are ignored by PI7C21P100.

PI7C21P100 forwards Type 1 to Type 1 configuration read and write transactions as delayed transactions in the PCI mode and as split transactions in PCI-X mode.

#### **4.4.4 SPECIAL CYCLES**

The Type 1 configuration mechanism is used to generate special cycle transactions in hierarchical PCI/PCI-X systems. Special cycle transactions can be generated from Type 1 configuration write transactions in either the upstream or the downstream direction.

PI7C21P100 initiates a special cycle on the target bus when a Type 1 configuration write transaction is detected on the initiating bus and the following conditions are met during the address phase:

- The lowest two address bits on AD[1:0] are equal to 01b.
- The device number in address bits AD[15:11] is equal to 1111b.
- The function number in address bits AD[10:8] is equal to 111b.
- The register number in address bits AD[7:2] is equal to 000000b.
- The bus number is equal to the value in the secondary bus number register for downstream transactions or equal to the value in the primary bus number register for upstream transactions.
- The bus command on CBE is a configuration write command.

When PI7C21P100 initiates the transaction on the target interface, the bus command is changed from configuration write to special cycle. Devices that use special cycles ignore the address and decode only the bus command. The data phase contains the special cycle message. The transaction is forwarded as a delayed transaction in PCI mode and as a split transaction in PCI-X mode. Once the transaction is completed on the target bus through detection of the master abort condition, PI7C21P100 completes the transaction on the initiating bus by accepting the retry on the delayed command in PCI mode or by generating a completion message in PCI-X mode. Special cycles received by PI7C21P100 as a target are ignored.

## **5 TRANSACTION ORDERING**

To maintain data coherency and consistency, PI7C21P100 complies with the ordering rules set forth in the *PCI Local Bus Specification, Revision 2.2* for PCI mode, and *PCI-X Addendum to the PCI Local Bus Specification, Revision 1.0a* for PCI-X mode. This chapter describes the ordering rules that control transaction forwarding across PI7C21P100.



## 5.1 GENERAL ORDERING GUIDELINES

Independent transactions on primary and secondary buses have a relationship only when those transactions cross PI7C21P100.

The following general ordering guidelines govern transactions crossing PI7C21P100:

- Requests terminated with target retry can be accepted and completed in any order with respect to other transactions that have been terminated with target retry. If the order of completion of delayed or split requests is important, the initiator should not start a second delayed or split transaction until the first one has been completed. If more than one delayed or split transaction is initiated, the initiator should repeat all retried requests, using some fairness algorithm. Repeating a delayed or split transaction cannot be contingent on completion of another delayed transaction. Otherwise, a deadlock can occur.
- Write transactions flowing in one direction have no ordering requirements with respect to write transactions flowing in the other direction. PI7C21P100 can accept posted write transactions on both interfaces at the same time, as well as initiate posted write transactions on both interfaces at the same time.
- The acceptance of a posted memory or memory write transaction as a target can never be contingent on the completion of a non-locked, non-posted transaction as a master. This is true for PI7C21P100 and must also be true for other bus agents. Otherwise, a deadlock can occur.
- PI7C21P100 accepts posted write transactions, regardless of the state of completion of any delayed transactions being forwarded across PI7C21P100.

## 5.2 ORDERING RULES

Table 5-1 SUMMARY OF TRANSACTION ORDERING IN PCI MODE and Table 5-2 show the ordering relationships of all the transactions and refers by number to the ordering rules that follow.

**Table 5-1 SUMMARY OF TRANSACTION ORDERING IN PCI MODE**

Pass	Posted Write	Delayed Read Request	Delayed Write Request	Delayed Read Completion	Delayed Write Completion
Posted Write	No	Yes	Yes	Yes	Yes
Delayed Read Request	No	Yes	Yes	Yes	Yes
Delayed Write Request	No	Yes	No	Yes	Yes
Delayed Read Completion	No <sup>1</sup>	Yes	Yes	Yes	Yes
Delayed Write Completion	No	Yes	Yes	Yes	No

1. If the relaxed ordering bit is set in PCI to PCI mode, or the enable relaxed ordering bit in the primary and/or secondary data buffering control registers is set in any other mode, read completions can pass memory writes.

**Table 5-2 SUMMARY OF TRANSACTION ORDERING IN PCI-X MODE**

Pass	Memory Write	Split Read Request	Split Write Request	Split Read Completion	Split Write Completion
Posted Write	No	Yes	Yes	Yes	Yes
Delayed Read Request	No	Yes	Yes	Yes	Yes
Delayed Write Request	No	Yes	No	Yes	Yes

Pass	Memory Write	Split Read Request	Split Write Request	Split Read Completion	Split Write Completion
Delayed Read Completion	No <sup>1</sup>	Yes	Yes	Yes <sup>2</sup>	Yes
Delayed Write Completion	No	Yes	Yes	Yes	No

1. If the relaxed ordering bit is set in PCI-X to PCI-X mode, or the enable relaxed ordering bit in the primary and/or secondary data buffering control registers is set in any other mode, read completions can pass memory writes.  
2. Split Read Completions with the same sequence ID must remain in address order.

## 6 CLOCKS

This chapter provides information about the clocks.

### 6.1 PRIMARY AND SECONDARY CLOCK INPUTS

The primary and secondary interface on PI7C21P100 each has its own clock input pin. P\_CLK is the clock input for the primary and S\_CLK is the input for the secondary (S\_CLK also controls the internal arbiter). The two clocks are independent of each other and may be run synchronously or asynchronously to each other at any value supported by the PCI or PCI-X specifications. Each interface utilizes a separate internal PLL (phase-locked loop) circuit when running in PCI-X mode. In PCI mode, the PLL's are bypassed, allowing for any clock frequency from 0 to 66MHz. If the primary is running at 133MHz in PCI-X mode, then the secondary is limited to a minimum frequency of 33MHz in conventional PCI mode. To run the secondary slower, the primary frequency needs to be reduced so that the ratio does not exceed 4:1.

### 6.2 CLOCK JITTER

PI7C21P100 tolerates a maximum of +/- 250ps of short term and long term jitter on the clock inputs. Short term jitter is defined as the relationship between one clock edge to the next subsequent clock edge for one clock cycle, and long term jitter is the same relationship over many clock cycles.

### 6.3 MODE AND CLOCK FREQUENCY DETERMINATION

#### 6.3.1 PRIMARY BUS

PI7C21P100 does not have I/O pins for the M66EN or PCIXCAP signals on the primary bus. PI7C21P100 adjusts its internal configuration based on the initialization pattern it detects on P\_DEVSEL#, P\_STOP#, and P\_TRDY# at the rising edge of P\_RST#. If the internal PLL is being used (the bus is configured in the PCI-X mode), a maximum of 100µs from the rising edge of P\_RST# is required to lock the PLL to the frequency of the clock supplied on the P\_CLK input.

### 6.3.2 SECONDARY BUS

The secondary interface is capable of operating in either conventional PCI mode or in PCI-X mode. PI7C21P100 controls the mode and frequency for the secondary bus by utilizing a pull-up circuit connected to S\_PCIXCAP. There are two pull-up resistors in the circuit as recommended by the PCI-X addendum. The first resistor is a weak pull-up (56K ohms) whose value is selected to set the voltage of S\_PCIXCAP below its low threshold when a PCI-X 66 device is attached to the secondary bus. The second resistor is a strong pull-up, externally wired between S\_PCIXCAP and S\_PCIXCAP\_PU. The value of the resistor (1K ohm) is selected to set the voltage of S\_PCIXCAP above its high threshold when all devices on the secondary are PCI-X 66 capable. To detect the mode and frequency of the secondary bus, S\_PCIXCAP\_PU is initially disabled and PI7C21P100 samples the value on S\_PCIXCAP.

If PI7C21P100 sees a logic LOW on S\_PCIXCAP, one or more devices on the secondary have either pulled the signal to ground (PCI-X 66 capable) or tied it to ground (only capable of conventional PCI mode). To differentiate between the two conditions, PI7C21P100 then enables S\_PCIXCAP\_PU to put the strong pull-up into the circuit. If S\_PCIXCAP remains at a logic LOW, it must be tied to ground by one or more devices, and the bus is initialized to conventional PCI mode. If S\_PCIXCAP\_PU can be pulled up, one or more devices are capable of only PCI-X 66 operation so the bus is initialized to PCI-X 66 mode. If PI7C21P100 sees a logic HIGH on S\_PCIXCAP, then all devices on the secondary bus are capable of PCI-X 133 operation. PI7C21P100 then samples S\_SEL100 to distinguish between the 66-100 MHz and the 100-133 MHz clock frequency ranges. If PI7C21P100 sees logic HIGH on S\_SEL100, the secondary bus is initialized to PCI-X 100 mode. If the value is LOW, PCI-X 133 is initialized. These two ranges allow adjustment of the clock frequency to account for bus loading conditions.

There is no pin for M66EN for the secondary interface on PI7C21P100 because the internal PLL is bypassed in conventional PCI mode. S\_CLK is used directly, eliminating the need to distinguish between conventional PCI 33 and conventional PCI 66.

**Table 6-1 PROGRAMMABLE PULL-UP CIRCUIT**

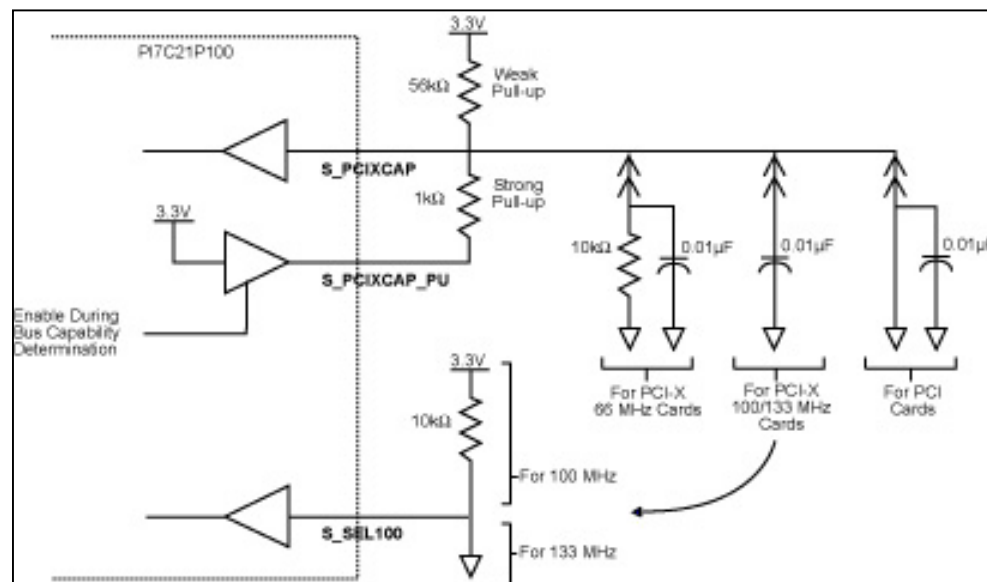

### 6.3.3 CLOCK STABILITY

To comply with PCI and PCI-X architecture specifications, the bus clock must be stable and running at the designated frequency for at least 100us after deassertion of the bus reset. S\_CLK\_STABLE is used to determine and detect when S\_CLK has become stable. During a bus reset, PI7C21P100 will wait for the assertion of S\_CLK\_STABLE before determining the mode and frequency. PI7C21P100 is expecting no more than one transition on the S\_CLK\_STABLE input from the “not stable” to the “stable” state. S\_CLK\_STABLE input may be tied HIGH if the secondary clock input is known to be always stable prior to the deassertion of the primary bus reset signal or the secondary bus reset bit of the bridge control register. Examples of sources for S\_CLK\_STABLE are lock indicators on circuits that employ PLL’s or “power good” indicators.

### 6.3.4 DRIVER IMPEDANCE SELECTION

The output drivers on PI7C21P100 are capable of two different output impedances, 40 ohm output impedance and a 20 ohm. The output impedance for the primary and secondary interfaces is separately controlled. PI7C21P100 selects a default impedance value at the deassertion of the bus reset based on the bus mode and frequency. If a bus is configured to be in PCI-X 133 mode, it is assumed that the bus will have fewer devices and have a higher impedance. In this case, the drivers utilize the 40 ohm output impedance mode. The 20 ohm output impedance mode is utilized for all other PCI-X and all PCI configurations, assuming that the bus is more heavily loaded and has lower impedance. Some applications do not follow these assumptions so two control signals are provided; P\_DRVR for the primary and S\_DRVR for the secondary. When these inputs are pulled HIGH, PI7C21P100 will change the output impedance of the drivers on their respective interfaces to the opposite state than was assumed by default, as shown in Table 6-2. The driver mode may not be changed dynamically, but can be changed during each bus reset.

**Table 6-2 DRIVER IMPEDANCE SELECTION**

Primary Bus Mode	Default Driver Mode (P_DRVR=0)	Driver Mode if (P_DRVR=1)	Secondary Bus Mode	Default Driver Mode (S_DRVR=0)	Driver Mode if (S_DRVR=1)
Conventional PCI	20 ohm	40 ohm	Conventional PCI	20 ohm	40 ohm
PCI-X 66	20 ohm	40 ohm	PCI-X 66	20 ohm	40 ohm
PCI-X 100	20 ohm	40 ohm	PCI-X 100	20 ohm	40 ohm
PCI-X 133	20 ohm	20 ohm	PCI-X 133	40 ohm	20 ohm

## 7 RESET

The primary and secondary interface each have their own asynchronous reset signal used at power-on and at other times to put PI7C21P100 into a known state. The reset signal on the primary (P\_RST#) is an input pin, while the reset signal on the secondary (S\_RST#) is an output pin driven by PI7C21P100.

## 7.1 PRIMARY INTERFACE RESET

When P\_RST# is asserted, the following events occur:

- PI7C21P100 immediately tri-states all primary PCI interface signals. S\_AD[31:0] and S\_CBE[3:0] are driven LOW on the secondary interface and other control signals are tri-stated.
- PI7C21P100 performs a chip reset.
- Registers that have default values are reset.

PI7C21P100 is not accessible during P\_RST#. After P\_RST# is deasserted in PCI-X mode, PI7C21P100 remains inaccessible for 100us to enable the internal PLL to lock to its target frequency. In conventional PCI mode, PI7C21P100 is held in reset 7 PCI clocks after the deassertion of P\_RST#.

## 7.2 SECONDARY INTERFACE RESET

PI7C21P100 is responsible for driving the secondary bus reset signals, S\_RST#. PI721P100 asserts S\_RST# when any of the following conditions are met:

**Signal P\_RST# is asserted.** Signal S\_RST# remains asserted as long as P\_RST# is asserted and does not de-assert until P\_RST# is de-asserted.

**The secondary reset bit in the bridge control register is set.** Signal S\_RST# remains asserted until a configuration write operation clears the secondary reset bit.

Several things must occur at or prior to the de-assertion of S\_RST#. Once P\_RST# is de-asserted or the secondary bus reset bit is changed from 1 to 0, PI7C21P100 will wait for the S\_CLK\_STABLE signal to be asserted before proceeding. S\_CLK must be stable at a frequency within the bus capability limits prior to the assertion of S\_CLK\_STABLE. Since the PCI Local Bus Specification requires that the bus clock be stable for at least 100us prior to the de-assertion of the bus reset, S\_CLK\_STABLE serves as a gate to a timer that ensures that this requirement is met. During this time delay period, the secondary bus mode and frequency is determined through the programmable pull-up circuit. This process may include up to 80us for the capacitive load on S\_PCIXCAP to be charged. By the time the 100us timer expires, the bus mode and frequency will have been determined. The S\_RST# signal is then de-asserted a minimum of ten secondary bus PCI clock cycles later.

When the secondary bus is operating in PCI-X mode, an internal PLL is used to source the clock tree for the secondary clock domain inside PI7C21P100. The appropriate range and tuning bits for the PLL are set once the mode and frequency are determined, and an internal PLL reset signal is deactivated to allow the PLL to begin locking to the S\_CLK input frequency. The PLL requires an allowance of 100us to accomplish this frequency lock. An internal reset is held on the logic in the secondary clock domain until this time period has elapsed. While the internal reset is active, PI7C21P100 will not respond to any secondary bus transactions. When the secondary bus is operating in PCI mode, the internal PLL for the secondary interface is not used. The internal PLL reset remains activated, keeping the PLL in the bypass mode, and the internal logic reset is held for 5 additional secondary PCI clock cycles.

**Table 7-1 DELAY TIMES FOR DE-ASSERTION OF S\_RST#**

	Conventional PCI	PCI-X 66	PCI-X 100	PCI-X 133
<b>T<sub>PIRSTDLY</sub></b>	7 primary clock cycles	6678 primary clock cycles 100us – 133us	13350 primary clock cycles 133us – 200us	13350 primary clock cycles 100us – 133us
<b>T<sub>XCAP</sub></b>	6675 primary clock cycles	6675 primary clock cycles 100us – 133us	13347 primary clock cycles 133us – 200us	13347 primary clock cycles 100us – 133us
<b>T<sub>SRSTDLY</sub></b>	11 secondary and 7 primary clock cycles	11 secondary and 7 primary clock cycles	11 secondary and 7 primary clock cycles	11 secondary and 7 primary clock cycles
<b>T<sub>SIRSTDLY</sub></b>	16 secondary clock cycles	6687 secondary clock cycles 100us – 133us	13350 secondary clock cycles 133us – 200us	13350 secondary clock cycles 100us – 133us

Note: Primary and secondary clock cycles refer to clock cycles whose period is determined by the P\_CLK and S\_CLK inputs.

**Table 7-2 DE-ASSERTION OF S\_RST#**

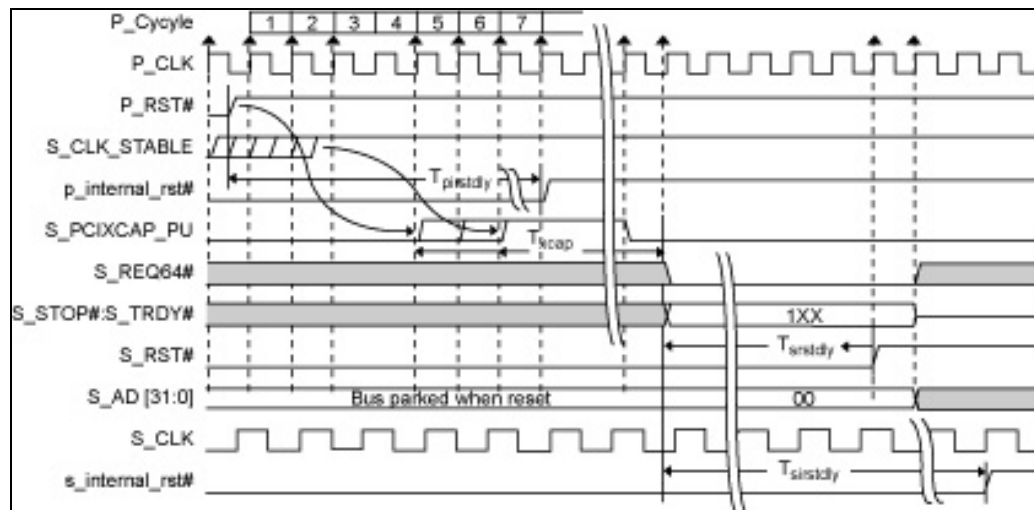

### 7.3 BUS PARKING & BUS WIDTH DETERMINATION

Bus parking refers to driving the AD[31:0], CBE[3:0], and PAR lines to a known value while the bus is idle. In general, the device implementing the bus arbiter is responsible for parking the bus or assigning another device to park the bus. A device parks the bus when the bus is idle, its bus grant is asserted, and the device's request is not asserted. The AD[31:0], CBE[3:0], and PAR signals are driven LOW after assertion of S\_RST#.

PI7C21P100 will assert S\_REQ64# for at least 10 PCI clock cycles to allow devices to determine whether they are connected on a 64-bit bus or 32-bit bus.

### 7.4 SECONDARY DEVICE MASKING

Secondary devices can be masked through configuration or power strapping of the secondary bus private device mask register. The process of converting Type 1 configuration transactions to Type 0 configuration transactions is modified by the contents of the secondary bus private device mask register. A configuration transaction that targets a device masked by this register is routed to device 15. Secondary bus architectures which are designed to support masking of

devices should not implement a device number 15 (i.e., S\_AD(31)). The device mask bit options (device numbers 1, 4, 5, 6, 7, 9, and 13) defined by PI7C21P100 allow architectures to support private device groupings that use a single or multiple interrupt binding.

## 7.5 ADDRESS PARITY ERRORS

PI7C21P100 checks address parity for all transactions on both buses, for all address and all bus commands. When PI7C21P100 detects an address parity error, the transaction will not be claimed and will be allowed to terminate with a master abort. The result of an address parity error will be controlled by the parity error response bits in both the command and bridge control registers.

## 7.6 OPTIONAL BASE ADDRESS REGISTER

The 64 bit Base Address register located in the configuration register at offsets 10h and 14h can optionally be used to acquire a 1 MB memory region at system initialization. PI7C21P100 uses this register to claim an additional prefetchable memory region for the secondary bus. When used with the secondary device masking, this allows for the acquisition of memory space for private devices that are not otherwise viewable by the system software. This 64 bit base address register and the memory space defined by it are enabled by the BAR\_EN. When BAR\_EN is pulled LOW, this register location returns zeros for reads and cannot be written. When BAR\_EN is pulled HIGH, the upper memory base address register and lower memory base address registers combined specify address bits 63:20 of a memory region. Memory accesses on the primary bus are compared against this register, if address bits 63:20 are equal to bits 63:20 of the address defined by the combination of the lower memory base address register and the upper memory base address register, the access is claimed by PI7C21P100 and passed through to the secondary bus. Memory accesses on the secondary bus are also compared against this register, if address bits 63:20 are equal to bits 63:20 of the address defined by the combination of the lower memory base address register and the upper memory base address register, the access is ignored by the bridge.

## 7.7 OPTIONAL CONFIGURATION ACCESS FROM THE SECONDARY BUS

PI7C21P100 accepts Type 0 configuration transactions when the following conditions are met during the address phase:

- S\_CBE[3:0]# indicates a configuration read or configuration write transaction
- S\_AD[1:0] are 00
- S\_IDSEL is asserted

Applications that require access to the bridge configuration registers via the secondary bus may control the initialization sequence through the P\_CFG\_BUSY pin and bit[2] offset 44h of the miscellaneous control register. When P\_CFG\_BUSY is pulled HIGH, bit[2] offset 44h is set to 1b at power up and reset. This causes PI7C21P100 to retry Type 0 configuration transactions on the primary bus that would otherwise be accepted. PI7C21P100 continues to retry these transactions until bit[2] offset 44h is set to 0b by a configuration write initiated on the secondary bus. This allows a device on the secondary bus to initialize the bridge and any private devices on the secondary bus without contention from devices accessing the bridge

through the primary bus. Applications that do not require access to the bridge configuration registers via the secondary bus should pull both the S\_IDSEL and P\_CFG\_BUSY pins LOW.

## **7.8 SHORT TERM CACHING**

Short Term Caching is a means to provide performance improvements where upstream devices are not able to stream data continuously to meet the prefetching needs of the PI7C21P100. When the master completes the transaction, the bridge is required to discard the balance of any data that was prefetched for the master. To prevent performance impacts when dealing with target devices that can only stream data of 128 to 512 bytes before disconnecting, PI7C21P100 utilizes Short Term Caching. This feature applies only when the secondary bus is operating in conventional PCI mode and provides a time limited read data cache in which the bridge will not discard prefetched read data after the request has been completed on the initiating bus. Short Term Caching is an optional feature which is enabled by setting bit[8] and bit[15] offset B8h of the Miscellaneous Control Register 2. When enabled, PI7C21P100 will not discard the additional prefetched data when the read transaction has been completed on the initiating bus. PI7C21P100 will continue to prefetch data up to the amount specified by bits [30:28] offset 40h of the Secondary Data Buffering Control Register. Should the initiator generate a new transaction requesting the previously prefetched data, PI7C21P100 will return that data. PI7C21P100 will discard the data approximately 64 secondary clocks after some of the data for a request has been returned to the initiator, and the initiator has not requested additional data. This feature applies to all secondary devices if enabled. System designers need to ensure that all attached devices have memory region(s) that are architected to be accessed by only one master and that the additional prefetching will present data to the initiator in the same state as if the initial transaction were continued. This feature should only be used in system designs that are able to ensure that the data provided to the master has not been modified since the initial transaction.



## 8 CONFIGURATION REGISTERS

PCI configuration defines a 64 DWORD space to define various attributes of PI7C21P100.

### 8.1 CONFIGURATION REGISTER SPACE MAP

**Table 8-1 CONFIGURATION SPACE MAP**

Bit Number				DWORD Address
31 – 24	23 – 16	15 – 8	7 - 0	
Device ID		Vendor ID		00h
Primary Status		Primary Command		04h
Class Code		Revision ID		08h
BIST	Header Type	Primary Latency Timer	Cache Line Size	0Ch
Lower Memory Base Address				10h
Upper Memory Base Address				14h
Secondary Latency Timer	Subordinate Bus Number	Secondary Bus Number	Primary Bus Number	18h
Secondary Status		I/O Limit	I/O Base	1Ch
Memory Limit		Memory Base		20h
Prefetchable Memory Limit		Prefetchable Memory Base		24h
Prefetchable Base Upper 32-bit				28h
Prefetchable Limit Upper 32-bit				2Ch
I/O Limit Upper 16-bit		I/O Base Upper 16-bit		30h
Reserved			Capability Pointer	34h
Expansion ROM Base Address				38h
Bridge Control		Interrupt Pin	Interrupt Line	3Ch
Secondary Data Buffering Control		Primary Data Buffering Control		40h
Reserved			Miscellaneous Control	44h
Reserved		Extended Chip Control 2	Extended Chip Control 1	48h
Reserved				4Ch
Reserved		Arbiter Mode		50h
Reserved			Arbiter Enable	54h
Reserved			Arbiter Priority	58h
Reserved			SERR# Disable	5Ch
Primary Retry Counter				60h
Secondary Retry Counter				64h
Reserved			Discard Timer Control	68h
Reserved			Retry and Timer Status	6Ch
Reserved			Opaque Memory Enable	70h
Opaque Memory Limit		Opaque Memory Base		74h
Opaque Memory Base Upper 32-bit				78h
Opaque Memory Limit Upper 32-bit				7Ch
PCI-X Secondary Status		Next Capability Pointer	PCI-X Capability ID	80h
PCI-X Bridge Status				84h
Secondary Bus Upstream Split Transaction				88h
Primary Bus Downstream Split Transaction				8Ch
Power Management Capabilities		Next Capabilities Pointer	Power Management ID	90h
PCI-to-PCI Bridge Support Extension		Power Management Control and Status		94h
Reserved				98h-Ach
Secondary Bus Private Device Mask				B0h
Reserved				B4h
Reserved		Miscellaneous Control 2		B8h
Reserved				BCh-FFh

### 8.1.1.1 SIGNAL TYPE DEFINITION

SIGNAL TYPE	DEFINITION
RO	READ ONLY
RW	READ / WRITE
RWC	READ / WRITE 1 TO CLEAR

### 8.1.2 VENDOR ID REGISTER – OFFSET 00h

BIT	FUNCTION	TYPE	DESCRIPTION
15:0	Vendor ID	RO	Identifies Pericom as the vendor of this device. Hardwired as 12D8h

### 8.1.3 DEVICE ID REGISTER – OFFSET 00h

BIT	FUNCTION	TYPE	DESCRIPTION
31:16	Device ID	RO	Identifies the device as PI7C21P100. Hardwired as 01A7h.

### 8.1.4 COMMAND REGISTER – OFFSET 04h

BIT	FUNCTION	TYPE	DESCRIPTION
15:10	Reserved	RO	Reserved. Returns 000000 when read.
9	Fast Back-to-Back Enable	RO	<b>Fast Back-to-Back Control</b> <b>0:</b> Prohibits PI7C21P100 to initiate fast back-to-back transactions on the primary This bit is ignored in PCI-X mode. Reset to 0
8	P_SERR# Enable	RW	<b>System Error Control</b> <b>0:</b> Disables the P_SERR# driver on the primary <b>1:</b> Enables the P_SERR# driver on the primary Reset to 0
7	Wait Cycle Control	RO	<b>Wait Cycle Control</b> <b>0:</b> Address/data stepping is disabled (primary and secondary) This bit is ignored in PCI-X mode. Returns 0 when read.
6	Parity Error Response	RW	<b>Parity Error Response</b> <b>0:</b> PI7C21P100 may ignore any detected parity errors and continue normal operation <b>1:</b> PI7C21P100 must take its normal action when a parity error is detected. Reset to 0
5	VGA Palette Snoop Enable	RW	<b>VGA Palette Snoop Control</b> <b>0:</b> Ignore VGA palette accesses on the primary <b>1:</b> Enables positive decoding response to VGA palette writes on the primary with I/O address bits AD[9:0] equal to 3C6h, 3C8h, and 3C9h (inclusive of ISA aliases; AD[15:10] are not decoded and may be any value. Reset to 0
4	Memory Write and Invalidate Enable	RO	<b>Memory Write and Invalidate Control</b> <b>0:</b> Disables Memory Write and Invalidate transactions. PI7C21P100 does not generate memory write and invalidate transactions. This bit is ignored in PCI-X mode. Returns 0 when read.
3	Special Cycle Enable	RO	<b>Special Cycle Control</b> <b>0:</b> PI7C21P100 does not respond as a target to Special Cycle transactions. Returns 0 when read.

BIT	FUNCTION	TYPE	DESCRIPTION
2	Bus Master Enable	RW	<b>Bus Master Control</b> <b>0:</b> PI7C21P100 does not initiate memory and I/O transactions on the primary and disables responses to memory and I/O transactions on the secondary <b>1:</b> Enables PI7C21P100 to operate as a master on the primary for memory and I/O transactions forwarded from the secondary. In PCI-X mode, PI7C21P100 is allowed to initiate a split completion transaction regardless of the status of this bit. Reset to 0
1	Memory Space Enable	RW	<b>Memory Space Control</b> <b>0:</b> Ignore memory transactions on the primary <b>1:</b> Enables responses to memory transactions on the primary Reset to 0
0	I/O Space Enable	RW	<b>I/O Space Control</b> <b>0:</b> Ignores I/O transactions on the primary <b>1:</b> Enables responses to I/O transaction on the primary Reset to 0

### 8.1.5 PRIMARY STATUS REGISTER – OFFSET 04h

BIT	FUNCTION	TYPE	DESCRIPTION
31	Detected Parity Error	RWC	<b>Detected Parity Error Status</b> <b>0:</b> Address or data parity error not detected by PI7C21P100 <b>1:</b> Address or data parity error detected by PI7C21P100 Reset to 0
30	Signaled System Error	RWC	<b>Signaled System Error Status</b> <b>0:</b> PI7C21P100 did not assert SERR# <b>1:</b> PI7C21P100 asserted SERR# Reset to 0
29	Received Master Abort	RWC	<b>Received Master Abort Status</b> <b>0:</b> Transaction not terminated with a bus master abort <b>1:</b> Transaction terminated with a bus master abort Reset to 0
28	Received Target Abort	RWC	<b>Received Target Abort Status</b> <b>0:</b> Transaction not terminated with a target abort <b>1:</b> Transaction terminated with a target abort Reset to 0
27	Signaled Target Abort	RWC	<b>Signaled Target Abort Status</b> <b>0:</b> Target device did not terminate transaction with a target abort <b>1:</b> Target device terminated transaction with a target abort
26:25	DEVSEL# Timing	RO	<b>DEVSEL# Timing Status</b> <b>01:</b> Medium decoding. Returns 01h when read.
24	Data Parity Error	RWC	<b>Data Parity Error Status</b> <b>0:</b> No data parity error detected <b>1:</b> Data parity error detected Reset to 0
23	Fast Back-to-Back Capable	RO	<b>Fast Back-to-Back Status</b> <b>0:</b> Target not capable of decoding fast back-to-back transactions in PCI-X mode <b>1:</b> Target capable of decoding fast back-to-back transactions in conventional PCI mode Returns 0 in PCI-X mode and 1 in conventional PCI mode
22	Reserved	RO	<b>Reserved.</b> Returns 0 when read.
21	66MHz Capable	RO	<b>66MHz Capable Status</b> <b>1:</b> Capable of 66MHz operation Returns 1 when read.
20	Capability List	RO	<b>Capability List</b> <b>1:</b> PI7C21P100 supports the capability list and offset 34h is the pointer to the data structure. Returns 0 when read.
19:16	Reserved	RO	<b>Reserved.</b> Returns 0000 when read.

**8.1.6 REVISION ID REGISTER – OFFSET 08h**

BIT	FUNCTION	TYPE	DESCRIPTION
7:0	Revision ID	RO	Specifies the revision of PI7C21P100. Read as 0h

**8.1.7 CLASS CODE REGISTER – OFFSET 08h**

BIT	FUNCTION	TYPE	DESCRIPTION
31:24	Class Code	RO	Specifies the base class code for PI7C21P100 identifying it as a Bridge device according to PCI specifications. Read as 06h
23:16	Sub Class Code	RO	Specifies the sub-class code identifying PI7C21P100 as a Bridge device. Read as 04h.
15:8	Programming Interface	RO	Subtractive decoding not supported. Read as 0h

**8.1.8 CACHE LINE SIZE REGISTER – OFFSET 0Ch**

BIT	FUNCTION	TYPE	DESCRIPTION
7:0	Cache Line Size	RW	Designates the cache line size for the system and is used when terminating memory write and invalidate transactions and when prefetching memory read transactions. Not used in PCI-X mode.  <b>bit[7:6]:</b> Not supported and should be 00b <b>bit[5]:</b> If 1, then cache line size = 32 DWORDS <b>bit[4]:</b> If 1, then cache line size = 16 DWORDS <b>bit[3]:</b> If 1, then cache line size = 8 DWORDS <b>bit[2]:</b> If 1, then cache line size = 4 DWORDS <b>bit[1:0]:</b> Not supported and should be 00b

**8.1.9 PRIMARY LATENCY TIMER – OFFSET 0Ch**

BIT	FUNCTION	TYPE	DESCRIPTION
15:11	Primary Latency Timer	RW	Designates the upper 5 bits of the primary latency timer in PCI clock units
10:8	Primary Latency Timer	RO	Designates the lower 3 bits of the primary latency timer in PCI clock units. Returns 000 when read to force 8-cycle increments for the latency timer.

**8.1.10 HEADER TYPE REGISTER – OFFSET 0Ch**

BIT	FUNCTION	TYPE	DESCRIPTION
23	Single Function Device	RO	Returns 0 when read to designate single function device
22:16	PCI-to-PCI Configuration	RO	Returns 0000001 when read.

**8.1.11 BIST REGISTER – OFFSET 0Ch**

BIT	FUNCTION	TYPE	DESCRIPTION
31:24	BIST	RO	BIST not supported. Returns 0 when read.

### 8.1.12 LOWER MEMORY BASE ADDRESS REGISTER – OFFSET 10h

BIT	FUNCTION	TYPE	DESCRIPTION
31:20	Memory Base Address	RW	Address bits[31:20] of the memory base address if BAR_EN is 1. If BAR_EN is 0, then this register is reserved and returns zeros when read.
19:4	Reserved	RO	Reserved. Returns 00h when read
3	Prefetchable Indicator	RO	Identifies the address range defined by this register is prefetchable. Returns 1 when read
2:1	Decoder Width	RO	Indicates that this is the lower portion of a 64-bit register. Returns 10b when read.
0	Decoder Type	RO	Indicates that this register is a memory decoder. Returns 0 when read.

### 8.1.13 UPPER MEMORY BASE ADDRESS REGISTER – OFFSET 14h

BIT	FUNCTION	TYPE	DESCRIPTION
31:0	Upper Memory Base Address	RW	Address bits[63:32] of the memory base address if BAR_EN is 1. If BAR_EN is 0, this register is reserved and returns zeros when read.

### 8.1.14 PRIMARY BUS NUMBER REGISTER – OFFSET 18h

BIT	FUNCTION	TYPE	DESCRIPTION
7:0	Primary Bus Number	RW	Records the bus number of the PCI segment that PI7C21P100 is connected to on the primary side. Reset to 00h

### 8.1.15 SECONDARY BUS NUMBER REGISTER – OFFSET 18h

BIT	FUNCTION	TYPE	DESCRIPTION
15:8	Secondary Bus Number	RW	Records the bus number of the PCI segment that PI7C21P100 is connected to on the secondary side. Reset to 00h

### 8.1.16 SUBORDINATE BUS NUMBER REGISTER – OFFSET 18h

BIT	FUNCTION	TYPE	DESCRIPTION
23:16	Subordinate Bus Number	RW	Records the highest bus number of the PCI segment that resides behind PI7C21P100. Reset to 00h

### 8.1.17 SECONDARY LATENCY TIMER REGISTER – OFFSET 18h

BIT	FUNCTION	TYPE	DESCRIPTION
31:24	Secondary Latency Timer	RW	Specifies the value of the secondary latency timer in PCI bus clock units. Reset to 00h in conventional PCI mode Reset to 40h in PCI-X mode

### 8.1.18 I/O BASE ADDRESS REGISTER – OFFSET 1Ch

BIT	FUNCTION	TYPE	DESCRIPTION
7:4	I/O Base Address	RW	Specifies the base of the I/O address range bits [15:12] and is used with the I/O limit register and I/O base upper 16 bits and I/O limit upper 16-bit registers
3:2	Reserved	RO	Reserved. Returns 00b when read.
1:0	32-bit I/O Addressing	RO	Returns 01b when read to indicate PI7C21P100 supports 32-bit I/O addressing

### 8.1.19 I/O LIMIT REGISTER – OFFSET 1Ch

BIT	FUNCTION	TYPE	DESCRIPTION
15:12	I/O Limit Address	RW	Address bits[15:12] of the limit address for the address range of I/O operations that are passed from primary to secondary
11:10	Reserved	RO	Reserved. Returns 00b when read.
9:8	32-bit I/O Addressing	RO	Returns 01b when read to indicate PI7C21P100 supports 32-bit I/O addressing

### 8.1.20 SECONDARY STATUS REGISTER – OFFSET 1Ch

BIT	FUNCTION	TYPE	DESCRIPTION
31	Detected Parity Error	RWC	<b>Detected Parity Error Status</b> <b>0:</b> Address or data parity error not detected by PI7C21P100 on the secondary <b>1:</b> Address or data parity error detected by PI7C21P100 on the secondary Reset to 0
30	Signaled System Error	RWC	<b>Signaled System Error Status</b> <b>0:</b> PI7C21P100 did not assert SERR# on the secondary <b>1:</b> PI7C21P100 asserted SERR# on the secondary Reset to 0
29	Received Master Abort	RWC	<b>Received Master Abort Status</b> <b>0:</b> Transaction not terminated with a bus master abort on the secondary <b>1:</b> Transaction terminated with a bus master abort on the secondary Reset to 0
28	Received Target Abort	RWC	<b>Received Target Abort Status</b> <b>0:</b> Transaction not terminated with a target abort <b>1:</b> Transaction terminated with a target abort Reset to 0
27	Signaled Target Abort	RWC	<b>Signaled Target Abort Status</b> <b>0:</b> Target device did not terminate transaction with a target abort <b>1:</b> Target device terminated transaction with a target abort Reset to 0
26:25	DEVSEL# Timing	RO	<b>DEVSEL# Timing Status</b> <b>01:</b> Medium decoding. Returns 01h when read.
24	Data Parity Error	RWC	<b>Data Parity Error Status</b> <b>0:</b> No data parity error detected on the secondary <b>1:</b> Data parity error detected on the secondary Reset to 0
23	Fast Back-to-Back Enable	RO	<b>Fast Back-to-Back Status</b> <b>0:</b> Target not capable of decoding fast back-to-back transactions in PCI-X mode <b>1:</b> Target capable of decoding fast back-to-back transactions in conventional PCI mode Returns 0 in PCI-X mode and 1 in conventional PCI mode
22	Reserved	RO	<b>Reserved.</b> Returns 0 when read.

BIT	FUNCTION	TYPE	DESCRIPTION
21	66MHz Capable	RO	<b>66MHz Capable Status</b> 1: Capable of 66MHz operation Returns 1 when read.
20:16	Reserved	RO	<b>Reserved.</b> Returns 00000 when read.

### 8.1.21 MEMORY BASE REGISTER – OFFSET 20h

BIT	FUNCTION	TYPE	DESCRIPTION
15:4	Memory Base	RW	Specifies the base of the memory mapped I/O address range bit[31:20] and is used with the Memory Limit register to specify a range of 32-bit addresses supported for memory mapped I/O transactions. Reset to 800h
3:0	Reserved	RO	Reserved. Returns 0 when read

### 8.1.22 MEMORY LIMIT REGISTER – OFFSET 20h

BIT	FUNCTION	TYPE	DESCRIPTION
31:20	Memory Limit	RW	Specifies address bits[31:20] of the limit address for the address range of memory mapped I/O operations. Reset to 000h
19:16	Reserved	RO	Reserved. Returns 0 when read

### 8.1.23 PREFETCHABLE MEMORY BASE REGISTER – OFFSET 24h

BIT	FUNCTION	TYPE	DESCRIPTION
15:4	Prefetchable Memory Base	RW	Specifies address bits[31:20] of the base address for the address range of prefetchable memory operations. Reset to 800h
3:0	64-bit Addressing	RO	Designates 64-bit addressing support. Returns 1h when read.

### 8.1.24 PREFETCHABLE MEMORY LIMIT REGISTER – OFFSET 24h

BIT	FUNCTION	TYPE	DESCRIPTION
31:20	Prefetchable Memory Limit	RW	Specifies address bits[31:20] of the limit address for the address range of prefetchable memory operations. Reset to 800h
19:16	64-bit Addressing	RO	Designates 64-bit addressing support. Returns 1h when read.

### 8.1.25 PREFETCHABLE BASE UPPER 32-BIT REGISTER – OFFSET 28h

BIT	FUNCTION	TYPE	DESCRIPTION
31:0	Prefetchable Base Upper 32-bit	RW	Specifies address bits[63:32] of the base address for the address range of prefetchable memory operations. Reset to 0000 0000h

**8.1.26 PREFETCHABLE LIMIT UPPER 32-BIT REGISTER – OFFSET 2Ch**

BIT	FUNCTION	TYPE	DESCRIPTION
31:0	Prefetchable Limit Upper 32-bit	RW	Specifies address bits[63:32] of the limit address for the address range of prefetchable memory operations. Reset to 0000 0000h

**8.1.27 I/O BASE UPPER 16-BIT REGISTER – OFFSET 30h**

BIT	FUNCTION	TYPE	DESCRIPTION
15:0	I/O Base Upper 16-bit	RW	Specifies address bits[31:16] of the base address for the address range of I/O operations. Reset to 0000h

**8.1.28 I/O LIMIT UPPER 16-BIT REGISTER – OFFSET 30h**

BIT	FUNCTION	TYPE	DESCRIPTION
31:16	I/O Limit Upper 16-bit	RW	Specifies address bits[31:16] of the limit address for the address range of I/O operations. Reset to 0000h

**8.1.29 CAPABILITY POINTER – OFFSET 34h**

BIT	FUNCTION	TYPE	DESCRIPTION
7:0	Capability Pointer	RO	Pointer to a capabilities list in the configuration space. Returns 80h when read.

**8.1.30 EXPANSION ROM BASE ADDRESS REGISTER – OFFSET 38h**

BIT	FUNCTION	TYPE	DESCRIPTION
31:0	Expansion ROM Base Address	RO	Expansion ROM not supported. Returns 00000000h when read

**8.1.31 INTERRUPT LINE REGISTER – OFFSET 3Ch**

BIT	FUNCTION	TYPE	DESCRIPTION
7:0	Interrupt Line Register	RW	For POST program to initialize to FFh, defining PI7C21P100 does not implement an interrupt pin.

**8.1.32 INTERRUPT PIN REGISTER – OFFSET 3Ch**

BIT	FUNCTION	TYPE	DESCRIPTION
15:8	Interrupt Pin Register	RO	Defines the interrupt pin, but PI7C21P100 does not implement any interrupt pins. Read as 00h.



### 8.1.33 BRIDGE CONTROL REGISTER – OFFSET 3Ch

BIT	FUNCTION	TYPE	DESCRIPTION
31:28	RESERVED	RO	<b>Reserved.</b> Returns 0h when read.
27	Discard Timer P_SERR# Enable	RW	<b>Discard Timer P_SERR# Enable</b> <b>0:</b> Does not assert P_SERR# on the primary interface as a result of the expiration of either the primary discard timer or secondary discard timer. <b>1:</b> Asserts P_SERR# on the primary interface as a result of the expiration of either the primary discard timer or secondary discard timer. This bit is ignored in PCI-X mode. Reset to 0h.
26	Master Timeout Status	RWC	<b>Master Timeout Status</b> <b>0:</b> No discard timer error <b>1:</b> Discard timer error (from primary or secondary discard timer) This bit remains 0 when in PCI-X mode. Reset to 0h.
25	Secondary Master Timeout Status	RW	<b>Secondary Master Timeout Status</b> <b>0:</b> The secondary discard timer counts 2 <sup>15</sup> PCI clock cycles. <b>1:</b> The secondary discard timer counts 2 <sup>10</sup> PCI clock cycles. If the secondary interface is in PCI-X mode, this bit is ignored. Reset to 0h.
24	Primary Master Timeout Status	RW	<b>Primary Master Timeout Status</b> <b>0:</b> The primary discard timer counts 2 <sup>15</sup> PCI clock cycles. <b>1:</b> The primary discard timer counts 2 <sup>10</sup> PCI clock cycles. If the primary interface is in PCI-X mode, this bit is ignored. Reset to 0h.
23	Fast Back-to-Back	RO	<b>Fast Back-to-Back Transaction Enable</b> Designates PI7C21P100 does not generate fast back-to-back transactions. Returns 0 when read.
22	Secondary Interface Reset	RW	<b>Secondary Interface Reset</b> <b>0:</b> Does not force the assertion of S_RST# on the secondary interface <b>1:</b> Forces the assertion of S_RST# on the secondary interface. Reset to 0h.
21	Master Abort Mode	RW	<b>Master Abort Mode</b> <b>0:</b> Do not report master aborts. Returns FFFFFFFFh on reads and discard data on writes. <b>1:</b> Report master aborts by signaling target abort if possible or by asserting SERR# (if enabled). If in PCI-X mode, PI7C21P100 will return a split completion message, leaving the host bridge to return FFFFFFFFh on any non-posted transaction when the non-posted transaction ends in a master abort. Reset to 0h.
20	RESERVED	RO	<b>Reserved.</b> Returns 0 when read.
19	VGA Enable	RW	<b>VGA Enable</b> <b>0:</b> Does not forward VGA compatible memory and I/O addresses from the primary to secondary interface unless they are enabled for forwarding by the defined I/O and memory address ranges. <b>1:</b> Forwards VGA compatible memory and I/O addresses from the primary to secondary interface (if the I/O enable and Memory enable bits are set) independent of the defined I/O and memory address ranges and independent of the ISA enable bit.
18	ISA Enable	RW	<b>ISA Enable</b> <b>0:</b> Forward downstream all I/O addresses in the address defined by the I/O base and limit registers. <b>1:</b> Forward upstream all I/O addresses in the address range defined by the I/O base and limit registers that are in the first 64KB of PCI I/O address space Reset to 0h.
17	S_SERR# Enable	RW	<b>S_SERR# Enable</b> <b>0:</b> Disable the forwarding of S_SERR# to P_SERR# <b>1:</b> Enable the forwarding of S_SERR# to P_SERR#. Reset to 0h.

BIT	FUNCTION	TYPE	DESCRIPTION
16	Parity Error Response Enable	RW	<b>Parity Error Response Enable</b> <b>0:</b> Ignore address and data parity errors on the secondary interface. <b>1:</b> Enable parity error detection on the secondary interface.

### 8.1.34 PRIMARY DATA BUFFERING CONTROL REGISTER – OFFSET 40h

BIT	FUNCTION	TYPE	DESCRIPTION
15	RESERVED	RO	<b>Reserved.</b> Returns 0h when read.
14:12	Maximum Memory Read Byte Count	RW	<b>Maximum Memory Read Byte Count</b> <b>000:</b> 512 bytes (default) <b>001:</b> 128 bytes <b>010:</b> 256 bytes <b>011:</b> 512 bytes <b>100:</b> 1024 bytes <b>101:</b> 2048 bytes <b>110:</b> 4096 bytes <b>111:</b> 512 bytes Maximum byte count is used by PI7C21P100 when generating read requests on the secondary interface in response to a memory read operation initiated on the primary interface which is in PCI mode and bits[9:8], bits[7:6], or bits[5:4] are set to full prefetch. Reset to 000
11	Enable Relaxed Ordering	RW	<b>Relaxed Ordering Enable</b> <b>0:</b> Relaxed ordering is disabled in conventional PCI mode. <b>1:</b> At the primary interface, read completions that occur after the first read completion are allowed to bypass posted writes and complete with a higher priority in conventional PCI mode. In PCI-X mode, the relaxed ordering bit in the attribute field will take precedence. Reset to 0
10	Primary Special Delayed Read Mode Enable	RW	<b>Primary Special Delayed Read Mode Enable</b> <b>0:</b> Retry any primary master which repeats its transaction with command code changes. <b>1:</b> Allows any primary master to change memory command code (MR, MRL, MRM) after it has received a retry. PI7C21P100 will complete the memory read transaction and return data back to the primary bus master if the address and byte enables are the same. This bit is ignored in PCI-X mode. Reset to 0
9:8	Primary Read Prefetch Mode	RW	<b>Primary Read Prefetch Mode</b> <b>00:</b> One cache line prefetch if memory read address is in the prefetchable range at the primary interface <b>01:</b> Reserved <b>10:</b> Full prefetch if memory read address is in the prefetchable range at the primary interface. <b>11:</b> Disconnect on the first DWORD. These bits are ignored in PCI-X mode. Reset to 00
7:6	Primary Read Line Prefetch Mode	RW	<b>Primary Read Line Prefetch Mode</b> <b>00:</b> One cache line prefetch if memory read line address is in prefetchable range at the primary interface <b>01:</b> Reserved <b>10:</b> Full prefetch if memory read multiple address is in prefetchable range at the primary interface <b>11:</b> Reserved. These bits are ignored if the primary interface is in PCI-X mode.
5:4	Primary Read Multiple Prefetch Mode	RW	<b>Primary Read Multiple Prefetch Mode</b> <b>00:</b> One cache line prefetch if memory read multiple address is in prefetchable range at the primary interface. <b>01:</b> Reserved. <b>10:</b> Full prefetch if memory read multiple address is in prefetchable range at the primary interface. <b>11:</b> Reserved. These bits are ignored if the primary interface is in PCI-X mode. Reset to 10.
3:0	RESERVED	RO	<b>Reserved.</b> Returns 0000 when read.

### 8.1.35 SECONDARY DATA BUFFERING CONTROL REGISTER – OFFSET 40h

BIT	FUNCTION	TYPE	DESCRIPTION
31	RESERVED	RO	<b>Reserved.</b> Returns 0h when read.
30:28	Maximum Memory Read Byte Count	RW	<b>Maximum Memory Read Byte Count</b> <b>000:</b> 512 bytes (default) <b>001:</b> 128 bytes <b>010:</b> 256 bytes <b>011:</b> 512 bytes <b>100:</b> 1024 bytes <b>101:</b> 2048 bytes <b>110:</b> 4096 bytes <b>111:</b> 512 bytes Maximum byte count is used by PI7C21P100 when generating read requests on the primary interface in response to a memory read operation initiated on the secondary interface which is in conventional PCI mode and bits[9:8], bits[7:6], or bits[5:4] are set to full prefetch. Reset to 000
27	Enable Relaxed Ordering	RW	<b>Relaxed Ordering Enable</b> <b>0:</b> Relaxed ordering is disabled in conventional PCI mode. <b>1:</b> At the secondary interface, read completions that occur after the first read completion are allowed to bypass posted writes and complete with a higher priority in conventional PCI mode. In PCI-X mode, the relaxed ordering bit in the attribute field will take precedence. Reset to 0
26	Secondary Special Delayed Read Mode Enable	RW	<b>Secondary Special Delayed Read Mode Enable</b> <b>0:</b> Retry any secondary master which repeats its transaction with command code changes. <b>1:</b> Allows any secondary master to change memory command code (MR, MRL, MRM) after it has received a retry. PI7C21P100 will complete the memory read transaction and return data back to the primary bus master if the address and byte enables are the same. This bit is ignored in PCI-X mode. Reset to 0
25:24	Secondary Read Prefetch Mode	RW	<b>Secondary Read Prefetch Mode</b> <b>00:</b> One cache line prefetch if memory read address is in the prefetchable range at the secondary interface <b>01:</b> Reserved <b>10:</b> Full prefetch if memory read address is in the prefetchable range at the secondary interface. <b>11:</b> Disconnect on the first DWORD. These bits are ignored in PCI-X mode. Reset to 00
23:22	Secondary Read Line Prefetch Mode	RW	<b>Secondary Read Line Prefetch Mode</b> <b>00:</b> One cache line prefetch if memory read line address is in prefetchable range at the secondary interface <b>01:</b> Reserved <b>10:</b> Full prefetch if memory read multiple address is in prefetchable range at the secondary interface <b>11:</b> Reserved. These bits are ignored if the secondary interface is in PCI-X mode.
21:20	Secondary Read Multiple Prefetch Mode	RW	<b>Secondary Read Multiple Prefetch Mode</b> <b>00:</b> One cache line prefetch if memory read multiple address is in prefetchable range at the secondary interface. <b>01:</b> Reserved. <b>10:</b> Full prefetch if memory read multiple address is in prefetchable range at the secondary interface. <b>11:</b> Reserved. These bits are ignored if the secondary interface is in PCI-X mode. Reset to 10.
19:16	RESERVED	RO	<b>Reserved.</b> Returns 0000 when read.

### 8.1.36 MISCELLANEOUS CONTROL REGISTER – OFFSET 44h

BIT	FUNCTION	TYPE	DESCRIPTION
7:3	RESERVED	RO	<b>Reserved.</b> Returns 00000 when read.
2	Primary Configuration Busy	RW	<b>Primary Configuration Busy</b> <b>0:</b> Type 0 configuration commands accepted normally on the primary interface. <b>1:</b> Type 0 configuration commands retried on the primary interface. This bit can be read from both the primary and secondary buses, but written only from the secondary bus. Reset value is based on P_CFG_BUSY. If P_CFG_BUSY is tied HIGH, reset to 1.
1	Data Parity Error Recovery Enable	RW	<b>Data Parity Error Recovery Enable</b> <b>0:</b> All PI7C21P100 to pass parity errors through. <b>1:</b> Cause SERR# to be asserted whenever either master-data-parity-error bit[8] is set. Reset to 1.
0	Parity Error Behavior	RW	<b>Parity Error Behavior</b> <b>0:</b> PI7C21P100 will pass the corrupted data sequence and PERR# will be asserted (if enabled), but PI7C21P100 will not complete the data and CBE# for performing completion on the initiating bus when detecting a data parity error on a non-posted write transaction. <b>1:</b> Transaction will be completed on the originating bus, PERR# will be asserted (if enabled), the appropriate status bits will be set, the data will be discarded and no request will be queued. Reset to 1.

### 8.1.37 EXTENDED CHIP CONTROL REGISTER 1 – OFFSET 48h

BIT	FUNCTION	TYPE	DESCRIPTION																		
7	RESERVED	RO	<b>Reserved.</b> Returns 0 when read.																		
6	Bridge Disconnect Discard Timer	RW	<b>Bridge Disconnect Discard Control</b> <b>0:</b> PI7C21P100 will discard remaining data after it disconnects the external master during burst memory reads transaction on the PCI source bus. <b>1:</b> PI7C21P100 will keep remaining data after it disconnects the external master during burst memory reads on the PCI source bus, until the external master returns or the discard timer expires. Reset to 0.																		
5	Memory Write Transaction Entry Control	RW	<b>Memory Write Transaction Entry Control</b> <b>0:</b> PI7C21P100 can accept 4 memory write transactions <b>1:</b> PI7C21P100 can accept 8 memory write transactions Reset to 0.																		
4	Synchronous Mode Enable	RW	<b>Synchronous Mode Enable</b> <b>0:</b> Synchronous mode is disabled, and the asynchronous clock input is supported. <b>1:</b> Synchronous mode is enabled and is used to decrease the frequency to frequency latency when PI7C21P100 is forwarding transactions through the bridge. The clock inputs have to be synchronized and the primary clock need to lead the secondary clock with the following combinations: <table style="margin-left: 40px;"> <tr> <td>Primary</td> <td>Secondary</td> <td>time</td> </tr> <tr> <td>33MHz</td> <td>33MHz</td> <td>0 – 14ns</td> </tr> <tr> <td>66MHz</td> <td>66MHz</td> <td>0 – 7ns</td> </tr> <tr> <td>66MHz</td> <td>33MHz</td> <td>3 – 14ns</td> </tr> <tr> <td>133MHz</td> <td>133MHz</td> <td>0 – 3ns</td> </tr> <tr> <td>133MHz</td> <td>66MHz</td> <td>3 – 7ns</td> </tr> </table> Reset to 0	Primary	Secondary	time	33MHz	33MHz	0 – 14ns	66MHz	66MHz	0 – 7ns	66MHz	33MHz	3 – 14ns	133MHz	133MHz	0 – 3ns	133MHz	66MHz	3 – 7ns
Primary	Secondary	time																			
33MHz	33MHz	0 – 14ns																			
66MHz	66MHz	0 – 7ns																			
66MHz	33MHz	3 – 14ns																			
133MHz	133MHz	0 – 3ns																			
133MHz	66MHz	3 – 7ns																			
3	Upstream Memory Read Prefetching Dynamic Control	RW	<b>Upstream Memory Read Prefetching Dynamic Control</b> <b>0:</b> Enable upstream memory read prefetching dynamic control <b>1:</b> Disable upstream memory read prefetching dynamic control Reset to 0 (Described in section 4.3.6)																		

BIT	FUNCTION	TYPE	DESCRIPTION
2	Downstream Memory Read Prefetching Dynamic Control	RW	<b>Downstream Memory Read Prefetching Dynamic Control</b> <b>0:</b> Enable downstream memory read prefetching dynamic control <b>1:</b> Disable downstream memory read prefetching dynamic control Reset to 0 (Described in section 4.3.6)
1:0	RESERVED	RO	<b>Reserved.</b> Returns 00 when read.

### 8.1.38 EXTENDED CHIP CONTROL REGISTER 2 – OFFSET 48h

BIT	FUNCTION	TYPE	DESCRIPTION
11:10	Minimum Free Space in Memory Data FIFO Control (Secondary)	RW	<b>Minimum Free Space in Memory Data FIFO Control (Secondary)</b> Selects the minimum free space in the memory data FIFO to accept memory writes on the secondary bus in PCI-X mode <b>00:</b> 128 bytes of free space to accept memory writes <b>01:</b> 256 bytes of free space to accept memory writes <b>10:</b> 512 bytes of free space to accept memory writes <b>11:</b> 128 bytes of free space to accept memory writes Reset to 00
9:8	Minimum Free Space in Memory Data FIFO Control (Primary)	RW	<b>Minimum Free Space in Memory Data FIFO Control (Primary)</b> Selects the minimum free space in the memory data FIFO to accept memory writes on the primary bus in PCI-X mode <b>00:</b> 128 bytes of free space to accept memory writes <b>01:</b> 256 bytes of free space to accept memory writes <b>10:</b> 512 bytes of free space to accept memory writes <b>11:</b> 128 bytes of free space to accept memory writes Reset to 00

### 8.1.39 ARBITER MODE REGISTER – OFFSET 50h

BIT	FUNCTION	TYPE	DESCRIPTION
15:8	Arbiter Fairness Counter	RW	<b>Arbiter Fairness Counter</b> These bits are the initialization value of a counter used by the internal arbiter. It controls the number of PCI bus cycles that the arbiter holds a device's PCI bus grant active after detecting a PCI bus request from another device. The counter is reloaded whenever a new PCI bus grant is asserted. For every new PCI bus grant, the counter is armed to decrement when it detects the de-assertion of FRAME#. If the arbiter fairness counter is set to 00h, the arbiter will not remove a device's PCI bus grant until the device has de-asserted its PCI bus request. Reset to 08h
7	GNT# Output Toggling Enable	RW	<b>GNT# Output Toggling Enable</b> <b>0:</b> GNT# not de-asserted after granted master asserts FRAME# <b>1:</b> GNT# de-asserts for 1 clock after 2 clocks from the granted master asserting FRAME#. Reset to 0
6	Broken Master Refresh	RW	<b>Broken Master Refresh</b> <b>0:</b> A broken master will be ignored forever except when it de-asserts its REQ# for at least 1 clock <b>1:</b> Refresh broken master state after all other masters have been served once. Reset to 0
5:2	RESERVED	RO	<b>Reserved.</b> Returns 0000 when read.
1	Broken Master Timeout Enable	RW	<b>Broken Master Timeout Enable</b> <b>0:</b> Broken master timeout disabled <b>1:</b> Broken master timeout enabled. This enables the internal arbiter to count 16 PCI bus cycles while waiting for FRAME# to become active when a device's PCI bus GNT# is active and the PCI bus is idle. If the broken master timeout expires, the PCI bus GNT# for the device is de-asserted. Reset to 0

BIT	FUNCTION	TYPE	DESCRIPTION
0	External Arbiter	RO	<b>External Arbiter</b> <b>0:</b> Enable internal arbiter. <b>1:</b> Disable internal arbiter. Reset to 0 or 1 according to the value of S_ARB# during the reset. If S_ARB# is tied LOW, then returns 0 when read. If S_ARB# is tied HIGH, then returns 1 when read.

### 8.1.40 ARBITER ENABLE REGISTER – OFFSET 54h

BIT	FUNCTION	TYPE	DESCRIPTION
7	RESERVED	RO	<b>Reserved.</b> Returns 0 when read.
6	Enable Arbiter 6	RW	<b>Enable Arbiter 6</b> <b>0:</b> Disable arbitration for master 6 <b>1:</b> Enable arbitration for master 6 Reset to 1
5	Enable Arbiter 5	RW	<b>Enable Arbiter 5</b> <b>0:</b> Disable arbitration for master 5 <b>1:</b> Enable arbitration for master 5 Reset to 1
4	Enable Arbiter 4	RW	<b>Enable Arbiter 4</b> <b>0:</b> Disable arbitration for master 4 <b>1:</b> Enable arbitration for master 4 Reset to 1
3	Enable Arbiter 3	RW	<b>Enable Arbiter 3</b> <b>0:</b> Disable arbitration for master 3 <b>1:</b> Enable arbitration for master 3 Reset to 1
2	Enable Arbiter 2	RW	<b>Enable Arbiter 2</b> <b>0:</b> Disable arbitration for master 2 <b>1:</b> Enable arbitration for master 2 Reset to 1
1	Enable Arbiter 1	RW	<b>Enable Arbiter 1</b> <b>0:</b> Disable arbitration for master 1 <b>1:</b> Enable arbitration for master 1 Reset to 1
0	Enable Arbiter 0	RW	<b>Enable Arbiter 0</b> <b>0:</b> Disable arbitration for internal bridge request <b>1:</b> Enable arbitration for internal bridge request Reset to 1

### 8.1.41 ARBITER PRIORITY REGISTER – OFFSET 58h

BIT	FUNCTION	TYPE	DESCRIPTION
7	RESERVED	RO	<b>Reserved.</b> Returns 0 when read.
6	Arbiter Priority 6	RW	<b>Arbiter Priority 6</b> <b>0:</b> Low priority request to master 6 <b>1:</b> High priority request to master 6 Reset to 0
5	Arbiter Priority 5	RW	<b>Arbiter Priority 5</b> <b>0:</b> Low priority request to master 5 <b>1:</b> High priority request to master 5 Reset to 0
4	Arbiter Priority 4	RW	<b>Arbiter Priority 4</b> <b>0:</b> Low priority request to master 4 <b>1:</b> High priority request to master 4 Reset to 0
3	Arbiter Priority 3	RW	<b>Arbiter Priority 3</b> <b>0:</b> Low priority request to master 3 <b>1:</b> High priority request to master 3 Reset to 0

BIT	FUNCTION	TYPE	DESCRIPTION
2	Arbiter Priority 2	RW	<b>Arbiter Priority 2</b> <b>0:</b> Low priority request to master 2 <b>1:</b> High priority request to master 2 Reset to 0
1	Arbiter Priority 1	RW	<b>Arbiter Priority 1</b> <b>0:</b> Low priority request to master 1 <b>1:</b> High priority request to master 1 Reset to 0
0	Arbiter Priority 0	RW	<b>Arbiter Priority 0</b> <b>0:</b> Low priority request to internal bridge <b>1:</b> High priority request to internal bridge Reset to 1

### 8.1.42 SERR# DISABLE REGISTER – OFFSET 5Ch

BIT	FUNCTION	TYPE	DESCRIPTION
7:5	RESERVED	RO	<b>Reserved.</b> Returns 000 when read.
4	PERR# on Posted Writes SERR# Disable	RW	<b>PERR# on Posted Writes SERR# Disable</b> <b>0:</b> Assert SERR# and set bit[30] offset 04h of the status register if bit[8] offset 04h in the command register is set. Discard the delayed transaction. <b>1:</b> Disable the assertion of SERR#. Reset to 0
3	Primary Discard Timer SERR# Disable	RW	<b>Primary Discard Timer SERR# Disable</b> <b>0:</b> Assert SERR# and update bit[30] offset 04h of the status register if the primary discard timer expires and bit[8] offset 04h in the command register is set and bit[27] offset 3Ch in the control register is set. Discard the delayed transaction and set bit[3] offset 6Ch of the retry and timer status register. <b>1:</b> Disable the assertion of SERR# if the primary discard timer expires. Discard the delayed transaction and set bit[3] offset 6Ch of the retry and timer status register. Reset to 0
2	Secondary Discard Timer SERR# Disable	RW	<b>Secondary Discard Timer SERR# Disable</b> <b>0:</b> Assert SERR# and update bit[30] offset 04h of the status register if the secondary discard timer expires and bit[8] offset 04h in the command register is set and bit[27] offset 3Ch in the control register is set. Discard the delayed transaction and set bit[3] offset 6Ch of the retry and timer status register. <b>1:</b> Disable the assertion of SERR# if the primary discard timer expires. Discard the delayed transaction and set bit[3] offset 6Ch of the retry and timer status register. Reset to 0
1	Primary Retry Count SERR# Disable	RW	<b>Primary Retry Count SERR# Disable</b> <b>0:</b> Assert SERR# and update bit[30] offset 04h of the status register if the primary retry counter expires and bit[8] offset 04h in the command register is set. Discard the transaction and set bit[1] offset 6Ch of the retry and timer status register. <b>1:</b> Disable the assertion of SERR# if the primary retry counter expires. Discard the transaction and set bit[1] offset 6Ch of the retry and timer status register. Reset to 0
0	Secondary Retry Count SERR# Disable	RW	<b>Secondary Retry Count SERR# Disable</b> <b>0:</b> Assert SERR# and update bit[30] offset 04h of the status register if the secondary retry counter expires and bit[8] offset 04h in the command register is set. Discard the transaction and set bit[0] offset 6Ch of the retry and timer status register. <b>1:</b> Disable the assertion of SERR# if the primary retry counter expires. Discard the transaction and set bit[0] offset 6Ch of the retry and timer status register. Reset to 0

### 8.1.43 PRIMARY RETRY COUNTER REGISTER – OFFSET 60h

BIT	FUNCTION	TYPE	DESCRIPTION
31	2G Retry Count Control	RW	<b>2G Retry Count Control</b> 1: Designates 2G retries before expiration Reset to 0
30:25	RESERVED	RO	<b>Reserved.</b> Returns 000000 when read.
24	16M Retry Count Control	RW	<b>16M Retry Count Control</b> 1: Designates 16M retries before expiration. Reset to 0
23:17	RESERVED	RO	<b>Reserved.</b> Returns 0000000 when read.
16	64K Retry Count Control	RW	<b>64K Retry Count Control</b> 1: Designates 64K retries before expiration. Reset to 0
15:9	RESERVED	RO	<b>Reserved.</b> Returns 0000000 when read.
8	256 Retry Count Control	RW	<b>256 Retry Count Control</b> 1: Designates 256 retries before expiration. Reset to 0
7:0	RESERVED	RO	<b>Reserved.</b> Returns 00000000 when read.

The below settings are the only allowed values. Other settings are not valid and will result in smaller retry counts. When the counter expires, the bridge discards the requested transaction on the primary bus and issues SERR# on the primary bus if enabled.

0000 0000: No expiration limit  
 8000 0000: Allow 2G retries before expiration  
 0100 0000: Allow 16M retries before expiration  
 0001 0000: Allow 64K retries before expiration  
 0000 0100: Allow 256 retries before expiration

### 8.1.44 SECONDARY RETRY COUNTER REGISTER – OFFSET 64h

BIT	FUNCTION	TYPE	DESCRIPTION
31	2G Retry Count Control	RW	<b>2G Retry Count Control</b> 1: Designates 2G retries before expiration Reset to 0
30:25	RESERVED	RO	<b>Reserved.</b> Returns 000000 when read.
24	16M Retry Count Control	RW	<b>16M Retry Count Control</b> 1: Designates 16M retries before expiration. Reset to 0
23:17	RESERVED	RO	<b>Reserved.</b> Returns 0000000 when read.
16	64K Retry Count Control	RW	<b>64K Retry Count Control</b> 1: Designates 64K retries before expiration. Reset to 0
15:9	RESERVED	RO	<b>Reserved.</b> Returns 0000000 when read.
8	256 Retry Count Control	RW	<b>256 Retry Count Control</b> 1: Designates 256 retries before expiration. Reset to 0
7:0	RESERVED	RO	<b>Reserved.</b> Returns 00000000 when read.

The below settings are the only allowed values. Other settings are not valid and will result in smaller retry counts. When the counter expires, the bridge discards the requested transaction on the secondary bus and issues SERR# on the primary bus if enabled.

0000 0000: No expiration limit  
 8000 0000: Allow 2G retries before expiration  
 0100 0000: Allow 16M retries before expiration  
 0001 0000: Allow 64K retries before expiration  
 0000 0100: Allow 256 retries before expiration



### 8.1.45 DISCARD TIMER CONTROL REGISTER – OFFSET 68h

BIT	FUNCTION	TYPE	DESCRIPTION
7:4	RESERVED	RO	<b>Reserved.</b> Returns 0000 when read.
3	Primary Discard Timer Short Duration	RW	<b>Primary Discard Timer Short Duration</b> <b>0:</b> Use bit[24] offset 3Ch of the bridge control register to indicate how many PCI clocks should be allowed before the primary discard timer expires. <b>1:</b> 64 PCI clocks allowed before the discard time expires. Reset to 0
2	Secondary Discard Timer Short Duration	RW	<b>Secondary Discard Timer Short Duration</b> <b>0:</b> Use bit[25] offset 3Ch of the bridge control register to indicate how many PCI clocks should be allowed before the secondary discard timer expires. <b>1:</b> 64 PCI clocks allowed before the secondary discard timer expires. Reset to 0
1	Primary Discard Timer Disable	RW	<b>Primary Discard Timer Disable</b> <b>0:</b> Enable the primary discard timer in conjunction with bit[27] offset 3Ch of the bridge control register <b>1:</b> Disable the primary discard timer in conjunction with bit[27] offset 3Ch of the bridge control register Reset to 0
0	Secondary Discard Timer Disable	RW	<b>Secondary Discard Timer Disable</b> <b>0:</b> Enable the secondary discard timer in conjunction with bit[27] offset 3Ch of the bridge control register <b>1:</b> Disable the secondary discard timer in conjunction with bit[27] offset 3Ch of the bridge control register Reset to 0

### 8.1.46 RETRY AND TIMER STATUS REGISTER – OFFSET 6Ch

BIT	FUNCTION	TYPE	DESCRIPTION
7:4	RESERVED	RO	<b>Reserved.</b> Returns 0000 when read.
3	Primary Discard Timer Status	RW	<b>Primary Discard Timer Status</b> <b>0:</b> The primary discard timer has not expired since the last reset. <b>1:</b> The primary discard timer has expired since the last reset. Reset to 0
2	Secondary Discard Timer Status	RW	<b>Secondary Discard Timer Status</b> <b>0:</b> The secondary discard timer has not expired since the last reset. <b>1:</b> The secondary discard timer has expired since the last reset. Reset to 0
1	Primary Retry Counter Status	RW	<b>Primary Retry Counter Status</b> <b>0:</b> The primary retry counter has not expired since the last request. <b>1:</b> The primary retry counter has expired since the last request. Reset to 0.
0	Secondary Retry Counter Status	RW	<b>Secondary Retry Counter Status</b> <b>0:</b> The secondary retry counter has not expired since the last request. <b>1:</b> The secondary retry counter has expired since the last request. Reset to 0.

### 8.1.47 OPAQUE MEMORY ENABLE REGISTER – OFFSET 70h

BIT	FUNCTION	TYPE	DESCRIPTION
7:1	RESERVED	RO	<b>Reserved.</b> Returns 0000000 when read.
0	Opaque Memory Enable	RW	<b>Opaque Memory Enable</b> <b>0:</b> Disable the opaque memory address range if OPAQUE_EN=0. <b>1:</b> Enable the opaque memory address range if OPAQUE_EN=1. Reset to the value of OPAQUE_EN during reset.

### 8.1.48 OPAQUE MEMORY BASE REGISTER – OFFSET 74h

BIT	FUNCTION	TYPE	DESCRIPTION
15:4	Opaque Memory Base Address	RW	<b>Opaque Memory Base Address</b> Address bits[31:20] of the opaque memory base address in conjunction with the opaque memory base upper 32-bit register and opaque memory limit address. In this range, memory transactions are not accepted by PI7C21P100 on both primary and secondary interfaces. Reset to 000h
3:0	Address Select	RO	<b>Address Select</b> Returns 0001 when read to indicate 64-bit addressing.

### 8.1.49 OPAQUE MEMORY LIMIT REGISTER – OFFSET 74h

BIT	FUNCTION	TYPE	DESCRIPTION
31:20	Opaque Memory Limit Address	RW	<b>Opaque Memory Limit Address</b> Address bits[31:20] of the opaque memory limit address in conjunction with the opaque memory limit upper 32-bit register and opaque memory base address. In this range, memory transactions are not accepted by PI7C21P100 on both primary and secondary interfaces. Reset to FFFh
19:16	Address Select	RO	<b>Address Select</b> Returns 0001 when read to indicate 64-bit addressing.

### 8.1.50 OPAQUE MEMORY BASE UPPER 32-BIT REGISTER – OFFSET 78h

BIT	FUNCTION	TYPE	DESCRIPTION
31:0	Opaque Memory Base Upper 32-bit Register	RW	<b>Opaque Memory Base Upper 32-bit Register</b> Address bits[63:32] of the opaque memory base address. In this range, memory transactions are not accepted by PI7C21P100 on both primary and secondary interfaces. Reset to FFFF FFFFh

### 8.1.51 OPAQUE MEMORY LIMIT UPPER 32-BIT REGISTER – OFFSET 7Ch

BIT	FUNCTION	TYPE	DESCRIPTION
31:0	Opaque Memory Base Upper 32-bit Register	RW	<b>Opaque Memory Base Upper 32-bit Register</b> Address bits[63:32] of the opaque memory limit address. In this range, memory transactions are not accepted by PI7C21P100 on both primary and secondary interfaces. Reset to FFFF FFFFh

### 8.1.52 PCI-X CAPABILITY ID REGISTER – OFFSET 80h

BIT	FUNCTION	TYPE	DESCRIPTION
7:0	PCI-X Capability ID	RO	<b>PCI-X Capability ID</b> Returns 07h when read to indicate that this register set of the Capabilities List is a PCI-X register set.

### 8.1.53 NEXT CAPABILITY POINTER REGISTER – OFFSET 80h

BIT	FUNCTION	TYPE	DESCRIPTION
15:8	Next Capability Pointer	RO	<b>Next Capability Pointer</b> Returns 90h when read to indicate that there are more list items in the Capabilities List.

### 8.1.54 PCI-X SECONDARY STATUS REGISTER – OFFSET 80h

BIT	FUNCTION	TYPE	DESCRIPTION																		
31:25	RESERVED	RO	<b>Reserved.</b> Returns 0000000 when read.																		
24:22	Secondary Clock Frequency	RO	<b>Secondary Clock Frequency</b> Enables the configuration software to determine what mode and what frequency PI7C21P100 set the secondary bus to the last time the secondary RST# was asserted.  <table border="1" style="width: 100%; border-collapse: collapse;"> <thead> <tr> <th>VALUE</th> <th>MAX CLOCK FREQUENCY</th> <th>MIN CLK PERIOD</th> </tr> </thead> <tbody> <tr> <td>000</td> <td>conventional mode</td> <td>N/A</td> </tr> <tr> <td>001</td> <td>66 MHz</td> <td>15ns</td> </tr> <tr> <td>010</td> <td>100 MHz</td> <td>10ns</td> </tr> <tr> <td>011</td> <td>133 MHz</td> <td>7.5ns</td> </tr> <tr> <td>1xx</td> <td>Reserved</td> <td>Reserved</td> </tr> </tbody> </table>	VALUE	MAX CLOCK FREQUENCY	MIN CLK PERIOD	000	conventional mode	N/A	001	66 MHz	15ns	010	100 MHz	10ns	011	133 MHz	7.5ns	1xx	Reserved	Reserved
VALUE	MAX CLOCK FREQUENCY	MIN CLK PERIOD																			
000	conventional mode	N/A																			
001	66 MHz	15ns																			
010	100 MHz	10ns																			
011	133 MHz	7.5ns																			
1xx	Reserved	Reserved																			
21	Split Request Delayed	RW	<b>Split Request Delayed</b> <b>0:</b> The bridge has not delayed a split request <b>1:</b> The bridge has delayed a split request because the bridge cannot forward a transaction to the secondary bus because there isn't enough room within the limit specified in the split transaction commitment limit field in the downstream split transaction control register. Reset to 0																		
20	Split Completion Overrun	RW	<b>Split Completion Overrun</b> <b>0:</b> PI7C21P100 has accepted all split completions. <b>1:</b> PI7C21P100 has terminated a split completion on the secondary bus with retry or disconnect at the next ADB because the bridge buffers were full. Reset to 0																		
19	Unexpected Split Completion	RW	<b>Unexpected Split Completion</b> <b>0:</b> No unexpected split completion has been received. <b>1:</b> An unexpected split completion has been received with the requested ID equal to the bridge's secondary bus number, device number 00h, and function number 0 on the bridge secondary interface. Reset to 0																		
18	Split Completion Discarded	RW	<b>Split Completion Discarded</b> <b>0:</b> No split completion has been discarded. <b>1:</b> A split completion moving toward the secondary bus has been discarded by the bridge because the requester would not accept it. Reset to 0.																		
17	133MHz Capable	RO	<b>133MHz Capable</b> Returns 1 when read to indicate PI7C21P100 is capable of 133MHz operation on the secondary interface.																		
16	64-bit Device	RO	<b>64-bit Device</b> Returns a 1 when the AD interface is 64-bits wide on the secondary bus and 64BIT_DEV#=1. Returns a 0 when 64BIT_DEV#=0.																		

### 8.1.55 PCI-X BRIDGE PRIMARY STATUS REGISTER – OFFSET 84h

BIT	FUNCTION	TYPE	DESCRIPTION
31:22	RESERVED	RO	<b>Reserved.</b> Returns 00000000 when read.

BIT	FUNCTION	TYPE	DESCRIPTION
21	Split Request Delayed	RW	<b>Split Request Delayed</b> <b>0:</b> PI7C21P100 has not delayed a split request. <b>1:</b> A split request moving toward the primary bus has been delayed by PI7C21P100 because there is not enough room within the limit specified in the split transaction commitment limit field in the upstream split transaction control register. Reset to 0
20	Split Completion Overrun	RW	<b>Split Completion Overrun</b> <b>0:</b> PI7C21P100 has accepted all split completions. <b>1:</b> PI7C21P100 has terminated a split completion on the primary bus with retry or disconnect at the next ADB because the buffers in the bridge were full. Reset to 0
19	Unexpected Split Completion	RW	<b>Unexpected Split Completion</b> <b>0:</b> No unexpected split completion has been received. <b>1:</b> An unexpected split completion has been received with the requested ID equal to the bridge's primary bus number, device number, and function number on the bridge primary interface. Reset to 0
18	Split Completion Discarded	RW	<b>Split Completion Discarded</b> <b>0:</b> No split completion has been discarded. <b>1:</b> A split completion moving toward the primary bus has been discarded by the bridge because the requester would not accept it. Reset to 0.
17	133MHz Capable	RO	<b>133MHz Capable</b> Returns 1 when read to indicate PI7C21P100 is capable of 133MHz operation on the primary interface.
16	64-bit Device	RO	<b>64-bit Device</b> Returns a 1 when the AD interface is 64-bits wide on the primary bus and P_REQ64#=0 at P_RST# de-assertion. Otherwise, AD interface is 32-bits wide.
15:8	Bus Number	RO	<b>Bus Number</b> This is an additional address from which the contents of the primary bus number register on type 1 configuration space header is read. The bridge uses the bus number, device number, and function number fields to create the completer ID when responding with a split completion to a read of an internal bridge register. These fields are also used for cases when one interface is in conventional PCI mode and the other is in PCI-X mode. Reset to 11111111
7:3	Device Number	RO	<b>Device Number</b> The device number (AD[15:11]) of a type 0 configuration transaction is assigned to the bridge by the connection of system hardware. Each time the bridge is addressed by a configuration write transaction, the bridge updates this register with the contents of AD[15:11] of the address phase of the configuration transaction, regardless of which register in the bridge is addressed by the transaction. The bridge is addressed by a configuration write transaction if all of the following are true: - The transaction uses a configuration write command - IDSEL is asserted during the address phase - AD[1:0] are 00 (type 0 configuration transaction) - AD[10:8] of the configuration address contain the appropriate function number Reset to 11111
2:0	Function Number	RO	<b>Function Number</b> The function number (AD[10:8]) of the address of a type 0 configuration transaction to which the bridge responds. Reset to 000

**8.1.56 SECONDARY BUS UPSTREAM SPLIT TRANSACTION REGISTER – OFFSET 88h**

BIT	FUNCTION	TYPE	DESCRIPTION
31:16	Split Transaction Commitment Limit	RW	<b>Split Transaction Commitment Limit</b> This field indicates the cumulative sequence size of the commitment limit in units of ADQ's. Software is allowed to program this field to any value greater than or equal to the contents of the split transaction capacity field. For example, if the limit is set to FFFFh, the bridge is allowed to forward all split requests of any size regardless of the amount of buffer space available. If the limit is set to 0100h or greater, causes the bridge to forward accepted split requests of any size regardless of the amount of buffer space available. The limit can be programmed at any time after reset. The value of the limit is equal to the split transaction capacity field reset. Reset to 0020h
15:0	Split Transaction Capability	RO	<b>Split Transaction Capability</b> The bridge returns 0020h to indicate that there are 32 ADQ's (4K bytes) available buffer space for storing split completions for memory reads. This applies to requesters on the secondary bus addressing completers on the primary bus. Reset to 0020h

**8.1.57 PRIMARY BUS DOWNSTREAM SPLIT TRANSACTION REGISTER – OFFSET 8Ch**

BIT	FUNCTION	TYPE	DESCRIPTION
31:16	Split Transaction Commitment Limit	RW	<b>Split Transaction Commitment Limit</b> This field indicates the cumulative sequence size of the commitment limit in units of ADQ's. Software is allowed to program this field to any value greater than or equal to the contents of the split transaction capacity field. For example, if the limit is set to FFFFh, the bridge is allowed to forward all split requests of any size regardless of the amount of buffer space available. If the limit is set to 0100h or greater, the bridge will forward accepted split requests of any size regardless of the amount of buffer space available. The limit can be programmed at any time after reset. The value of the limit is equal to the split transaction capacity field reset. Reset to 0020h
15:0	Split Transaction Capability	RO	<b>Split Transaction Capability</b> The bridge returns 0020h to indicate that there are 32 ADQ's (4K bytes) available buffer space for storing split completions for memory reads. This applies to requesters on the secondary bus addressing completers on the primary bus. Reset to 0020h

**8.1.58 POWER MANAGEMENT ID REGISTER – OFFSET 90h**

BIT	FUNCTION	TYPE	DESCRIPTION
7:0	Power Management ID	RO	<b>Power Management ID</b> Returns 01h when read indicating that this register set of the capabilities list is a power management register set.

**8.1.59 NEXT CAPABILITIES POINTER REGISTER – OFFSET 90h**

BIT	FUNCTION	TYPE	DESCRIPTION
15:8	Next Capabilities Pointer	RO	<b>Next Capabilities Pointer</b> Returns 00h when read indicating that there are no more list items in the capabilities list.

**8.1.60 POWER MANAGEMENT CAPABILITIES REGISTER – OFFSET 90h**

BIT	FUNCTION	TYPE	DESCRIPTION
31:27	PME# Pin Support	RO	<b>PME# Pin Support</b> Returns 00000 when read designating that PI7C21P100 does not support the PME# pin.
26	D2 Power State Support	RO	<b>D2 Power State Support</b> Returns 0 when read indicating the D2 power management state is not supported.
25	D1 Power State Support	RO	<b>D1 Power State Support</b> Returns 0 when read indicating the D1 power management state is not supported.
24:22	AUX Current	RO	<b>AUX Current</b> Returns 000 when read indicating PME# generation is not supported in the D3 <sub>cold</sub> power management state.
21	Device Specific Initialization	RO	<b>Device Specific Initialization</b> Returns 0 when read indicating that no special initialization of this function beyond the standard PCI configuration header is required following transition to the D0 un-initialized state.
20	RESERVED	RO	<b>Reserved.</b> Returns 0 when read.
19	PME Clock	RO	<b>PME Clock</b> Returns 0 when read indicating PME# generation is not supported.
18:16	Version	RO	<b>Version</b> Returns 010 when read indicating PI7C21P100 complies with revision 2.0 of the PCI Power Management Interface Specification.

**8.1.61 POWER MANAGEMENT CONTROL AND STATUS REGISTER – OFFSET 94h**

BIT	FUNCTION	TYPE	DESCRIPTION
15	PME Status	RO	<b>PME Status</b> Returns 0 when read indicating PI7C21P100 does not support the PME# pin.
14:13	Data Scale	RO	<b>Data Scale</b> Returns 00 when read indicating the data register is not implemented.
12:9	Data Select	RO	<b>Data Select</b> Returns 0000 when read indicating the data register is not implemented.
8	PME Enable	RO	<b>PME Enable</b> Returns 0 when read indication PME# generation is not supported.
7:2	RESERVED	RO	<b>Reserved.</b> Returns 000000 when read.

BIT	FUNCTION	TYPE	DESCRIPTION
1:0	Power State	RW	<p><b>Power State</b>  Determines and reflects the current power state. If an unimplemented power state is written to this register, the bridge completes the write transaction, ignores the write data, and does not change the value of this field. Writing a value of D0 when the previous state was D3 will cause a device reset to occur without activating the secondary S_RST#.</p> <p>00     D0  01     D1 (not supported)  10     D2 (not supported)  11     D3</p> <p>Reset to 00</p>

**8.1.62     PCI-TO-PCI BRIDGE SUPPORT EXTENSION REGISTER – OFFSET 94h**

BIT	FUNCTION	TYPE	DESCRIPTION
31:24	Data Register	RO	<p><b>Data Register</b>  Returns 0 when read indicating the data register is not implemented.</p>
23	Bus Power / Clock Control	RO	<p><b>Bus Power / Clock Control</b>  Returns 0 when read indicating the bus power / clock control is disabled and the secondary clock cannot be controlled by PI7C21P100.</p>
22	B2/B3 Support for D3 <sub>HOT</sub>	RO	<p><b>B2/B3 Support for D3<sub>HOT</sub></b>  Returns 0 when read indicating B2/B3 support for D3<sub>HOT</sub> power management state is disabled.</p>
21:16	RESERVED	RO	<p><b>Reserved.</b> Returns 000000 when read.</p>

**8.1.63     SECONDARY BUS PRIVATE DEVICE MASK REGISTER – OFFSET B0h**

BIT	FUNCTION	TYPE	DESCRIPTION
31:30	RESERVED	RW	<p><b>Reserved.</b> Returns 00 when read.</p>
29	Private Device Mask 13	RW	<p><b>Private Device Mast 13</b>  <b>0:</b> Rerouting disabled for device 13  <b>1:</b> Block assertion of S_AD[29] for configuration transactions to device 13 and assert S_AD[31] instead.</p>
28:26	RESERVED	RW	<p><b>Reserved.</b> Returns 000 when read.</p>
25	Private Device Mask 9	RW	<p><b>Private Device Mask 9</b>  <b>0:</b> Rerouting disabled for device 9  <b>1:</b> Block assertion of S_AD[25] for configuration transactions to device 9 and assert S_AD[31] instead.</p>
24	RESERVED	RW	<p><b>Reserved.</b> Returns 0 when read.</p>
23	Private Device Mask 7	RW	<p><b>Private Device Mask 7</b>  <b>0:</b> Rerouting disabled for device 7  <b>1:</b> Block assertion of S_AD[23] for configuration transactions to device 7 and assert S_AD[31] instead.</p>
22	Private Device Mask 6	RW	<p><b>Private Device Mask 6</b>  <b>0:</b> Rerouting disabled for device 6  <b>1:</b> Block assertion of S_AD[22] for configuration transactions to device 6 and assert S_AD[31] instead.</p>
21	Private Device Mask 5	RW	<p><b>Private Device Mask 5</b>  <b>0:</b> Rerouting disabled for device 5  <b>1:</b> Block assertion of S_AD[21] for configuration transactions to device 5 and assert S_AD[31] instead.</p>

BIT	FUNCTION	TYPE	DESCRIPTION
20	Private Device Mask 4	RW	<b>Private Device Mask 4</b> <b>0:</b> Rerouting disabled for device 4 <b>1:</b> Block assertion of S_AD[20] for configuration transactions to device 4 and assert S_AD[31] instead.
19:18	RESERVED	RW	<b>Reserved.</b> Returns 00 when read.
17	Private Device Mask 1	RW	<b>Private Device Mask 1</b> <b>0:</b> Rerouting disabled for device 1 <b>1:</b> Block assertion of S_AD[17] for configuration transactions to device 1 and assert S_AD[31] instead.
16:0	RESERVED	RW	<b>Reserved.</b> Returns 000000000000000000 when read.

### 8.1.64 MISCELLANEOUS CONTROL REGISTER 2 – OFFSET B8h

BIT	FUNCTION	TYPE	DESCRIPTION
15	Short Term Caching	RW	<b>Short Term Caching</b> <b>0:</b> Short term caching is disabled <b>1:</b> Short term caching is enabled.
14:10	RESERVED	RO	<b>Reserved.</b> Returns 00000 when read.
9	Primary Prefetching Persistence Control	RW	<b>Primary Prefetching Persistence Control</b> <b>0:</b> PI7C21P100 discontinues prefetching on the secondary bus when the target disconnects, regardless of how much data has been buffered <b>1:</b> PI7C21P100 continues prefetching on the secondary bus despite target disconnects until either the byte count specified by Primary Data Buffering Control Register has been prefetched, or the initiator disconnects.
8	Secondary Prefetching Persistence Control	RW	<b>Secondary Prefetching Persistence Control</b> <b>0:</b> PI7C21P100 discontinues prefetching on the primary bus when the target disconnects, regardless of how much data has been buffered <b>1:</b> PI7C21P100 continues prefetching on the primary bus despite target disconnects until either the byte count specified by Primary Data Buffering Control Register has been prefetched, or the initiator disconnects.
7:0	RESERVED	RO	<b>Reserved.</b> Returns 00h when read.



## 9 IEEE 1149.1 COMPATIBLE JTAG CONTROLLER

An IEEE 1149.1 compatible Test Access Port (TAP) controller and associated TAP pins are provided to support boundary scan in PI721P100 for board-level continuity test and diagnostics. The TAP pins assigned are TCK, TDI, TDO, TMS and TRST#. All digital input, output, input/output pins are tested except TAP pins.

The IEEE 1149.1 Test Logic consists of a TAP controller, an instruction register, and a group of test data registers including Bypass and Boundary Scan registers. The TAP controller is a synchronous 16-state machine driven by the Test Clock (TCK) and the Test Mode Select (TMS) pins. An independent power on reset circuit is provided to ensure the machine is in TEST\_LOGIC\_RESET state at power-up. The JTAG signal lines are not active when the PCI resource is operating PCI bus cycles.

### 9.1 INSTRUCTION REGISTER

PI7C21P100 implements a 4-bit Instruction register to control the operation of the JTAG logic. The defined instruction codes are shown in. Those bit combinations that are not listed are equivalent to the BYPASS (1111) instruction:

Instruction	Operation Code (binary)	Register Selected	Operation
EXTEST	0000	Boundary Scan	Drives / receives off-chip test data
SAMPLE	0100	Boundary Scan	Samples inputs / pre-loads outputs
HIGHZ	0101	Bypass	Tri-states outputs
IDCODE	0110	Device ID	Accesses the Device ID register, to read manufacturer ID, part number, and version number
BYPASS	1111	Bypass	Selected Bypass Register
INT_SCAN	0010	Internal Scan	Scan test

### 9.2 BYPASS REGISTER

The required bypass register, a one-bit shift register, provides the shortest path between TDI and TDO when a bypass instruction is in effect. This allows rapid movement of test data to and from other components on the board. This path can be selected when no test operation is being performed on the PI7C21P100.

### 9.3 DEVICE ID REGISTER

This register identifies Pericom as the manufacturer of the device and details the part number and revision number for the device.

BIT	TYPE	VALUE	DESCRIPTION
31:28	RO	0h	Version number
27:12	RO	01A7h	Last 4 digits (hex) of the die part number
11:0	RO	47Fh	Pericom identifier assigned by JEDEC Bit 0 is set to 1

## 9.4 BOUNDARY SCAN REGISTER

The boundary scan register is a required set of serial-shiftable register cells, formed by connecting boundary scan cells placed at the device's signal pins into a shift register path. The VDD, VSS, and JTAG pins are NOT in the boundary-scan chain. The input to the shift register is TDI and the output from the shift register is TDO. There are 4 different types of boundary scan cells, based on the function of each signal pin.

The boundary scan register cells are dedicated logic and do not have any system function. Data may be loaded into the boundary-scan register master cells from the device input pins and output pin-drivers in parallel by the mandatory SAMPLE and EXTEST instructions. Parallel loading takes place on the rising edge of TCK.

## 9.5 JTAG BOUNDARY REGISTER ORDER

**Table 9-1 JTAG BOUNDARY SCAN REGISTER**

Boundary Scan Register Number	Pin Name	Ball Location	Type	Tri-state Control Cell
0	P_ACK64#	A2	BIDIR	208
1	P_AD[0]	B13	BIDIR	209
2	P_AD[1]	C13	BIDIR	210
3	P_AD[2]	B14	BIDIR	211
4	P_AD[3]	C15	BIDIR	212
5	P_AD[4]	A19	BIDIR	213
6	P_AD[5]	B16	BIDIR	214
7	P_AD[6]	C16	BIDIR	215
8	P_AD[7]	A20	BIDIR	216
9	P_AD[8]	B17	BIDIR	217
10	P_AD[9]	C17	BIDIR	218
11	P_AD[10]	C19	BIDIR	219
12	P_AD[11]	D18	BIDIR	220
13	P_AD[12]	F22	BIDIR	221
14	P_AD[13]	F20	BIDIR	222
15	P_AD[14]	G22	BIDIR	223
16	P_AD[15]	B20	BIDIR	224
17	P_AD[16]	G21	BIDIR	225
18	P_AD[17]	H22	BIDIR	226
19	P_AD[18]	H21	BIDIR	227
20	P_AD[19]	J22	BIDIR	228
21	P_AD[20]	J21	BIDIR	229
22	P_AD[21]	K22	BIDIR	230
23	P_AD[22]	D23	BIDIR	231
24	P_AD[23]	K21	BIDIR	232
25	P_AD[24]	E23	BIDIR	233
26	P_AD[25]	K20	BIDIR	234
27	P_AD[26]	G23	BIDIR	235
28	P_AD[27]	L22	BIDIR	236
29	P_AD[28]	L21	BIDIR	237
30	P_AD[29]	M22	BIDIR	238
31	P_AD[30]	M21	BIDIR	239
32	P_AD[31]	J23	BIDIR	240

Boundary Scan Register Number	Pin Name	Ball Location	Type	Tri-state Control Cell
33	P_AD[32]	L1	BIDIR	241
34	P_AD[33]	J1	BIDIR	242
35	P_AD[34]	J2	BIDIR	243
36	P_AD[35]	H1	BIDIR	244
37	P_AD[36]	G1	BIDIR	245
38	P_AD[37]	J3	BIDIR	246
39	P_AD[38]	E1	BIDIR	247
40	P_AD[39]	H2	BIDIR	248
41	P_AD[40]	H3	BIDIR	249
42	P_AD[41]	G3	BIDIR	250
43	P_AD[42]	F2	BIDIR	251
44	P_AD[43]	B1	BIDIR	252
45	P_AD[44]	F3	BIDIR	253
46	P_AD[45]	E3	BIDIR	254
47	P_AD[46]	F4	BIDIR	255
48	P_AD[47]	D2	BIDIR	256
49	P_AD[48]	C2	BIDIR	257
50	P_AD[49]	B5	BIDIR	258
51	P_AD[50]	B6	BIDIR	259
52	P_AD[51]	D6	BIDIR	260
53	P_AD[52]	B7	BIDIR	261
54	P_AD[53]	C7	BIDIR	262
55	P_AD[54]	B3	BIDIR	263
56	P_AD[55]	B8	BIDIR	264
57	P_AD[56]	A3	BIDIR	265
58	P_AD[57]	B9	BIDIR	266
59	P_AD[58]	C9	BIDIR	267
60	P_AD[59]	B10	BIDIR	268
61	P_AD[60]	A4	BIDIR	269
62	P_AD[61]	C10	BIDIR	270
63	P_AD[62]	D10	BIDIR	271
64	P_AD[63]	B11	BIDIR	272
65	P_CBE[0]	A13	BIDIR	273
66	P_CBE[1]	B18	BIDIR	274
67	P_CBE[2]	D14	BIDIR	275
68	P_CBE[3]	A15	BIDIR	276
69	P_CBE[4]	A5	BIDIR	277
70	P_CBE[5]	C11	BIDIR	278
71	P_CBE[6]	B12	BIDIR	279
72	P_CBE[7]	A7	BIDIR	280
73	P_CLK	E21	INPUT	-
74	P_DEVSEL	D21	BIDIR	281
75	P_FRAME	A17	BIDIR	282
76	P_GNT	C20	INPUT	-
77	P_IDSEL	B19	INPUT	-
78	P_IRDY	A16	BIDIR	283
79	P_LOCK	C14	INPUT	-
80	P_DRVR	E2	INPUT	-
81	P_PAR	C18	BIDIR	284
82	P_PAR64	A9	BIDIR	285
83	P_CFG_BUSY	C6	INPUT	-
84	P_PERR	C8	BIDIR	286

Boundary Scan Register Number	Pin Name	Ball Location	Type	Tri-state Control Cell
85	P_REQ64	C12	BIDIR	287
86	P_REQ	B21	OUTPUT	288
87	P_RST	R3	INPUT	-
88	P_SERR	B4	OUTPUT	289
89	P_STOP	C4	BIDIR	290
90	P_TRDY	B15	BIDIR	291
91	S_ACK64	AA8	BIDIR	292
92	S_AD[0]	AA9	BIDIR	293
93	S_AD[1]	AB9	BIDIR	294
94	S_AD[2]	AC9	BIDIR	295
95	S_AD[3]	AC11	BIDIR	296
96	S_AD[4]	AB11	BIDIR	297
97	S_AD[5]	AC15	BIDIR	298
98	S_AD[6]	AA12	BIDIR	299
99	S_AD[7]	AA13	BIDIR	300
100	S_AD[8]	AC17	BIDIR	301
101	S_AD[9]	AB15	BIDIR	302
102	S_AD[10]	AA16	BIDIR	303
103	S_AD[11]	Y18	BIDIR	304
104	S_AD[12]	AB18	BIDIR	305
105	S_AD[13]	AA20	BIDIR	306
106	S_AD[14]	V20	BIDIR	307
107	S_AD[15]	W21	BIDIR	308
108	S_AD[16]	V21	BIDIR	309
109	S_AD[17]	V22	BIDIR	310
110	S_AD[18]	U21	BIDIR	311
111	S_AD[19]	U22	BIDIR	312
112	S_AD[20]	T22	BIDIR	313
113	S_AD[21]	W23	BIDIR	314
114	S_AD[22]	R21	BIDIR	315
115	S_AD[23]	T23	BIDIR	316
116	S_AD[24]	R22	BIDIR	317
117	S_AD[25]	N23	BIDIR	318
118	S_AD[26]	P20	BIDIR	319
119	S_AD[27]	M23	BIDIR	320
120	S_AD[28]	P21	BIDIR	321
121	S_AD[29]	P22	BIDIR	322
122	S_AD[30]	N21	BIDIR	323
123	S_AD[31]	N22	BIDIR	324
124	S_AD[32]	K4	BIDIR	325
125	S_AD[33]	K3	BIDIR	326
126	S_AD[34]	K2	BIDIR	327
127	S_AD[35]	L3	BIDIR	328
128	S_AD[36]	L2	BIDIR	329
129	S_AD[37]	R1	BIDIR	330
130	S_AD[38]	M3	BIDIR	331
131	S_AD[39]	M2	BIDIR	332
132	S_AD[40]	N3	BIDIR	333
133	S_AD[41]	N2	BIDIR	334
134	S_AD[42]	U1	BIDIR	335
135	S_AD[43]	P4	BIDIR	336
136	S_AD[44]	W1	BIDIR	337

Boundary Scan Register Number	Pin Name	Ball Location	Type	Tri-state Control Cell
137	S_AD[45]	P3	BIDIR	338
138	S_AD[46]	Y1	BIDIR	339
139	S_AD[47]	P2	BIDIR	340
140	S_AD[48]	R3	BIDIR	341
141	S_AD[49]	R2	BIDIR	342
142	S_AD[50]	T3	BIDIR	343
143	S_AD[51]	T2	BIDIR	344
144	S_AD[52]	U3	BIDIR	345
145	S_AD[53]	U2	BIDIR	346
146	S_AD[54]	V4	BIDIR	347
147	S_AD[55]	V2	BIDIR	348
148	S_AD[56]	Y3	BIDIR	349
149	S_AD[57]	Y6	BIDIR	350
150	S_AD[58]	AA5	BIDIR	351
151	S_AD[59]	AA6	BIDIR	352
152	S_AD[60]	AB6	BIDIR	353
153	S_AD[61]	AA7	BIDIR	354
154	S_AD[62]	AB7	BIDIR	355
155	S_AD[63]	AB8	BIDIR	356
156	S_CBE[0]	AB12	BIDIR	357
157	S_CBE[1]	AB16	BIDIR	358
158	S_CBE[2]	AB14	BIDIR	359
159	S_CBE[3]	AA15	BIDIR	360
160	S_CBE[4]	AC8	BIDIR	361
161	S_CBE[5]	AA11	BIDIR	362
162	S_CBE[6]	AB10	BIDIR	363
163	S_CBE[7]	Y10	BIDIR	364
164	S_CLK	AB23	INPUT	-
165	S_CLK_STABLE	W3	INPUT	-
166	S_DEVSEL	AC21	BIDIR	365
167	S_FRAME	AA14	BIDIR	366
168	S_GNT[1]	AA19	OUTPUT	202
169	S_GNT[2]	AB1	OUTPUT	203
170	S_GNT[3]	Y2	OUTPUT	204
171	S_GNT[4]	AC5	OUTPUT	205
172	S_GNT[5]	AB4	OUTPUT	206
173	S_GNT[6]	AC4	OUTPUT	207
174	S_ARB	T21	INPUT	-
175	S_IRDY	AC19	BIDIR	367
176	S_LOCK	AC20	BIDIR	368
177	S_DRVR	AC7	INPUT	-
178	S_PAR	AA17	BIDIR	369
179	S_PAR64	AA10	BIDIR	370
180	S_PCIXCAP	R23	INPUT	-
181	S_PCIXCAP_PU	AA1	OUTPUT	376
182	S_PERR	AB17	BIDIR	371
183	S_REQ[1]	AA23	INPUT	-
184	S_REQ[2]	AA2	INPUT	-
185	S_REQ[3]	W2	INPUT	-
186	S_REQ[4]	AB3	INPUT	-
187	S_REQ[5]	AB5	INPUT	-
188	S_REQ64	AB13	INPUT	372

Boundary Scan Register Number	Pin Name	Ball Location	Type	Tri-state Control Cell
189	S_REQ[6]	AC3	INPUT	-
190	S_RST	U23	OUTPUT	-
191	S_SEL100	V3	INPUT	-
192	S_SERR	AB19	INPUT	-
193	S_STOP	AB20	BIDIR	373
194	S_TRDY	Y14	BIDIR	374
195	BAR_EN	G2	INPUT	-
196	RESERVED	D1	INPUT	-
197	XCLK_OUT	D3	OUTPUT	375
198	S_IDSEL	AA22	INPUT	-
199	64BIT_DEV	Y22	INPUT	-
200	IDSEL_ROUTE	AC22	-	-
201	OPAQUE_EN	AA18	INPUT	-
202	-	-	CONTROL	-
203	-	-	CONTROL	-
204	-	-	CONTROL	-
205	-	-	CONTROL	-
206	-	-	CONTROL	-
207	-	-	CONTROL	-
208	-	-	CONTROL	-
209	-	-	CONTROL	-
210	-	-	CONTROL	-
211	-	-	CONTROL	-
212	-	-	CONTROL	-
213	-	-	CONTROL	-
214	-	-	CONTROL	-
215	-	-	CONTROL	-
216	-	-	CONTROL	-
217	-	-	CONTROL	-
218	-	-	CONTROL	-
219	-	-	CONTROL	-
220	-	-	CONTROL	-
221	-	-	CONTROL	-
222	-	-	CONTROL	-
223	-	-	CONTROL	-
224	-	-	CONTROL	-
225	-	-	CONTROL	-
226	-	-	CONTROL	-
227	-	-	CONTROL	-
228	-	-	CONTROL	-
229	-	-	CONTROL	-
230	-	-	CONTROL	-
231	-	-	CONTROL	-
232	-	-	CONTROL	-
233	-	-	CONTROL	-
234	-	-	CONTROL	-
235	-	-	CONTROL	-
236	-	-	CONTROL	-
237	-	-	CONTROL	-
238	-	-	CONTROL	-
239	-	-	CONTROL	-
240	-	-	CONTROL	-

Boundary Scan Register Number	Pin Name	Ball Location	Type	Tri-state Control Cell
241	-	-	CONTROL	-
242	-	-	CONTROL	-
243	-	-	CONTROL	-
244	-	-	CONTROL	-
245	-	-	CONTROL	-
246	-	-	CONTROL	-
247	-	-	CONTROL	-
248	-	-	CONTROL	-
249	-	-	CONTROL	-
250	-	-	CONTROL	-
251	-	-	CONTROL	-
252	-	-	CONTROL	-
253	-	-	CONTROL	-
254	-	-	CONTROL	-
255	-	-	CONTROL	-
256	-	-	CONTROL	-
257	-	-	CONTROL	-
258	-	-	CONTROL	-
259	-	-	CONTROL	-
260	-	-	CONTROL	-
261	-	-	CONTROL	-
262	-	-	CONTROL	-
263	-	-	CONTROL	-
264	-	-	CONTROL	-
265	-	-	CONTROL	-
266	-	-	CONTROL	-
267	-	-	CONTROL	-
268	-	-	CONTROL	-
269	-	-	CONTROL	-
270	-	-	CONTROL	-
271	-	-	CONTROL	-
272	-	-	CONTROL	-
273	-	-	CONTROL	-
274	-	-	CONTROL	-
275	-	-	CONTROL	-
276	-	-	CONTROL	-
277	-	-	CONTROL	-
278	-	-	CONTROL	-
279	-	-	CONTROL	-
280	-	-	CONTROL	-
281	-	-	CONTROL	-
282	-	-	CONTROL	-
283	-	-	CONTROL	-
284	-	-	CONTROL	-
285	-	-	CONTROL	-
286	-	-	CONTROL	-
287	-	-	CONTROL	-
288	-	-	CONTROL	-
289	-	-	CONTROL	-
290	-	-	CONTROL	-
291	-	-	CONTROL	-
292	-	-	CONTROL	-

Boundary Scan Register Number	Pin Name	Ball Location	Type	Tri-state Control Cell
293	-	-	CONTROL	-
294	-	-	CONTROL	-
295	-	-	CONTROL	-
296	-	-	CONTROL	-
297	-	-	CONTROL	-
298	-	-	CONTROL	-
299	-	-	CONTROL	-
300	-	-	CONTROL	-
301	-	-	CONTROL	-
302	-	-	CONTROL	-
303	-	-	CONTROL	-
304	-	-	CONTROL	-
305	-	-	CONTROL	-
306	-	-	CONTROL	-
307	-	-	CONTROL	-
308	-	-	CONTROL	-
309	-	-	CONTROL	-
310	-	-	CONTROL	-
311	-	-	CONTROL	-
312	-	-	CONTROL	-
313	-	-	CONTROL	-
314	-	-	CONTROL	-
315	-	-	CONTROL	-
316	-	-	CONTROL	-
317	-	-	CONTROL	-
318	-	-	CONTROL	-
319	-	-	CONTROL	-
320	-	-	CONTROL	-
321	-	-	CONTROL	-
322	-	-	CONTROL	-
323	-	-	CONTROL	-
324	-	-	CONTROL	-
325	-	-	CONTROL	-
326	-	-	CONTROL	-
327	-	-	CONTROL	-
328	-	-	CONTROL	-
329	-	-	CONTROL	-
330	-	-	CONTROL	-
331	-	-	CONTROL	-
332	-	-	CONTROL	-
333	-	-	CONTROL	-
334	-	-	CONTROL	-
335	-	-	CONTROL	-
336	-	-	CONTROL	-
337	-	-	CONTROL	-
338	-	-	CONTROL	-
339	-	-	CONTROL	-
340	-	-	CONTROL	-
341	-	-	CONTROL	-
342	-	-	CONTROL	-
343	-	-	CONTROL	-
344	-	-	CONTROL	-



Boundary Scan Register Number	Pin Name	Ball Location	Type	Tri-state Control Cell
345	-	-	CONTROL	-
346	-	-	CONTROL	-
347	-	-	CONTROL	-
348	-	-	CONTROL	-
349	-	-	CONTROL	-
350	-	-	CONTROL	-
351	-	-	CONTROL	-
352	-	-	CONTROL	-
353	-	-	CONTROL	-
354	-	-	CONTROL	-
355	-	-	CONTROL	-
356	-	-	CONTROL	-
357	-	-	CONTROL	-
358	-	-	CONTROL	-
359	-	-	CONTROL	-
360	-	-	CONTROL	-
361	-	-	CONTROL	-
362	-	-	CONTROL	-
363	-	-	CONTROL	-
364	-	-	CONTROL	-
365	-	-	CONTROL	-
366	-	-	CONTROL	-
367	-	-	CONTROL	-
368	-	-	CONTROL	-
369	-	-	CONTROL	-
370	-	-	CONTROL	-
371	-	-	CONTROL	-
372	-	-	CONTROL	-
373	-	-	CONTROL	-
374	-	-	CONTROL	-
375	-	-	CONTROL	-
376	-	-	CONTROL	-

## 10 ELECTRICAL INFORMATION

### 10.1 MAXIMUM RATINGS

Stresses greater than those listed under MAXIMUM RATINGS may cause permanent damage to the device. This is a stress rating only and functional operation of the device at these or any conditions above those indicated in the operational sections of this specification is not implied. Exposure to absolute maximum rating conditions for extended periods of time may affect reliability.

SYMBOL	PARAMETER	RATING	UNITS
V <sub>DD</sub>	Core logic power supply	TBD	V
V <sub>DD2</sub>	I/O power supply voltage	TBD	V
V <sub>IN</sub>	Input voltage	TBD	V
V <sub>OUT</sub>	Output voltage	TBD	V
T <sub>A</sub>	Ambient operating temperature	0 to 70	°C
T <sub>J</sub>	Maximum junction temperature	125	°C
T <sub>STG</sub>	Storage temperature	-55 to 125	°C
P <sub>WC</sub>	Worst case power dissipation	TBD	W
I <sub>OUT</sub>	Short circuit output current	TBD	mA

### 10.2 DC SPECIFICATIONS

SYMBOL	PARAMETER	RATING			UNITS
		min	typ	max	
V <sub>DD</sub>	Core logic power supply	2.3	2.5	2.7	V
V <sub>DD2</sub>	I/O power supply voltage	3.0	3.3	3.6	V
V <sub>IH</sub>	Input High voltage	2.0	-	V <sub>DDI</sub> * + 0.5	V
V <sub>IL</sub>	Input Low voltage	-0.3	-	0.3 V <sub>DDI</sub> *	V
C <sub>IN</sub>	Input pin capacitance	-	-	8.0	pF

\* V<sub>DDI</sub> is in reference to the power supply of the input device.

### 10.3 AC SPECIFICATIONS

**Figure 10-1 PCI SIGNAL TIMING MEASUREMENTS**

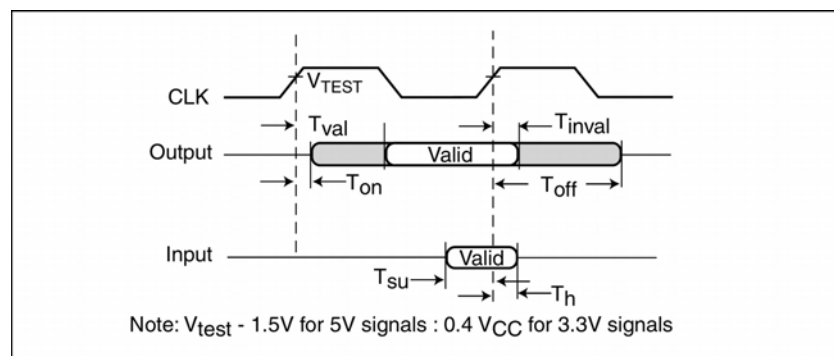

**Table 10-1 AC TIMING SPECIFICATIONS PCI-X MODE**

Symbol	Parameter	PCI-X 133		PCI-X 100		PCI-X 66		Units
		min	max	min	max	min	max	
T <sub>su</sub>	Input setup time to CLK – bussed signals	1.2	-	1.2	-	1.7	-	ns
T <sub>su(ptp)</sub>	Input setup time to CLK – point-to-point signals	1.2	-	1.2	-	1.7	-	ns
T <sub>h</sub>	Input signal hold time from CLK	0.5	-	0.5	-	0.5	-	ns
T <sub>val</sub>	CLK to signal valid delay – bussed signals	0.7	3.8	0.7	3.8	0.7	3.8	ns
T <sub>val(ptp)</sub>	CLK to signal valid delay – point-to-point signals	0.7	3.8	0.7	3.8	0.7	3.8	ns
T <sub>on</sub>	Float to active delay	0	-	0	-	0	-	ns
T <sub>off</sub>	Active to float delay	-	7	-	7	-	7	ns

**Table 10-2 AC TIMING SPECIFICATIONS CONVENTIONAL PCI MODE**

Symbol	Parameter	PCI 66		PCI 33		Units
		min	max	min	max	
T <sub>su</sub>	Input setup time to CLK – bussed signals	3	-	7	-	ns
T <sub>su(ptp)</sub>	Input setup time to CLK – point-to-point signals	5	-	10, 12	-	ns
T <sub>h</sub>	Input signal hold time from CLK	0	-	0	-	ns
T <sub>val</sub>	CLK to signal valid delay – bussed signals	2	6	2	11	ns
T <sub>val(ptp)</sub>	CLK to signal valid delay – point-to-point signals	2	6	2	12	ns
T <sub>on</sub>	Float to active delay	2	-	2	-	ns
T <sub>off</sub>	Active to float delay	-	14	-	14	ns

## 10.4 POWER CONSUMPTION

PARAMETER	RATING			UNITS
	min	typ	max	
Power dissipation for V <sub>DD</sub> (2.5V)		1.33		W
Power dissipation for V <sub>DD2</sub> (3.3V)		0.46		W

\*Running at 133MHz

## 11 MECHANICAL INFORMATION

Figure 11-1 PACKAGE DIAGRAM 31 X 31mm 304-PIN CSBGA

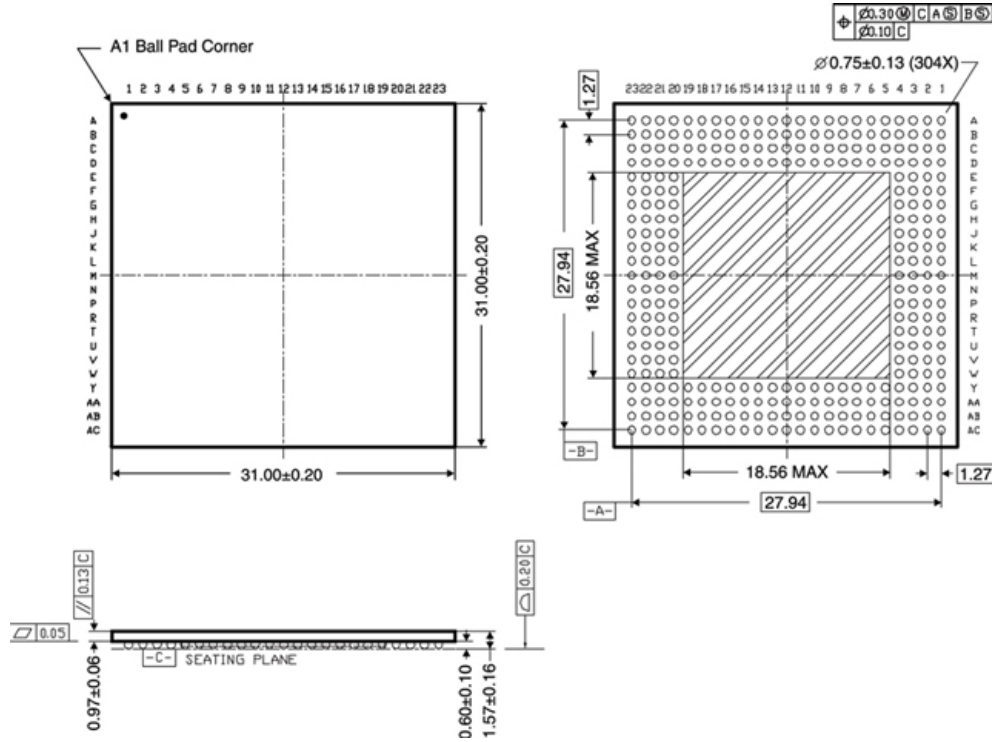

## 12 ORDERING INFORMATION

PART NUMBER	SPEED	PIN - PACKAGE	TEMPERATURE
PI7C21P100NH	133MHz	304-PINS - CSGA	0°C TO 85°C
PI7C21P100NHE	133MHz	Pb-free & Green, 304-PINS - CSBGA	0°C TO 85°C

*NOTES:*