

5-V Dual Differential PECL Buffer-to-TTL Translator

FEATURES

- Dual 5-V Differential PECL-to-TTL Buffer
- 24-mA TTL Outputs
- Operating Range
 - PECL $V_{CC} = 4.75\text{ V to }5.25\text{ V}$ with $GND = 0\text{ V}$
- Support for Clock Frequencies of 250 MHz (TYP)
- 3.5-ns Typical Propagation Delay
- Output Default Low with Inputs Left Open or $<1.3\text{ V}$
- Internal Input 50-k Ω Pull-Down Resistor
- Built-In Temperature Compensation
- Drop-In Compatible to the MC100ELT23

APPLICATIONS

- Data and Clock Transmission Over Backplane
- Signaling Level Conversion for Clock or Data

DESCRIPTION

The SN65ELT23 is a low power dual PECL-to-TTL translator device. The device includes circuitry to maintain a known logic low level when inputs are in an open condition. The SN65ELT23 is housed in an industry standard SOIC-8 package and is also available in an optional TSSOP-8 package.

PIN ASSIGNMENT

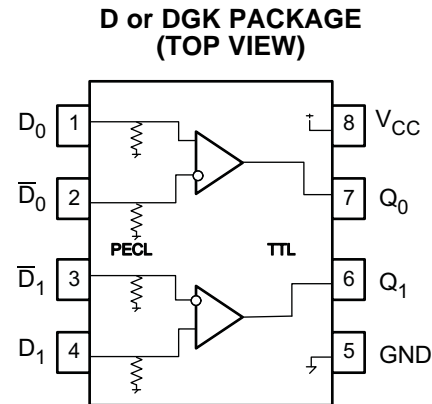

Table 1. Pin Descriptions

PIN	FUNCTION
$D_0, \bar{D}_0, D_1, \bar{D}_1$	PECL inputs
Q_0, Q_1	TTL outputs
V_{CC}	Positive supply
GND	Ground

ORDERING INFORMATION⁽¹⁾⁽²⁾

PART NUMBER	PART MARKING	PACKAGE	LEAD FINISH
SN65ELT23D	ELT23	SOIC	NiPdAu
SN65ELT23DGK	SIKI	MSOP	NiPdAu

(1) For the most current package and ordering information, see the Package Option Addendum at the end of this document, or see the TI web site at www.ti.com.

(2) Leaded device options are not initially available; contact a sales representative for further details.



Please be aware that an important notice concerning availability, standard warranty, and use in critical applications of Texas Instruments semiconductor products and disclaimers thereto appears at the end of this data sheet.



These devices have limited built-in ESD protection. The leads should be shorted together or the device placed in conductive foam during storage or handling to prevent electrostatic damage to the MOS gates.

ABSOLUTE MAXIMUM RATINGS⁽¹⁾

PARAMETER	CONDITIONS	VALUE	UNIT
Absolute supply voltage, V_{CC}		6	V
Absolute input voltage, V_I	$GND = 0$ and $V_I \leq V_{CC}$	0 to 6	V
Output current	Continuous	50	mA
	Surge	100	
Operating temperature range		–40 to 85	°C
Storage temperature range		–65 to 150	°C

(1) Stresses beyond those listed under absolute maximum ratings may cause permanent damage to the device. These are stress ratings only and functional operation of the device at these or any conditions beyond those indicated under recommended operating conditions is not implied. Exposure to absolute-maximum-rated conditions for extended periods may affect device reliability.

DISSIPATION RATINGS

PACKAGE	CIRCUIT BOARD MODEL	POWER RATING $T_A < 25^\circ\text{C}$ (mW)	THERMAL RESISTANCE, JUNCTION-TO-AMBIENT NO AIRFLOW	DERATING FACTOR $T_A > 25^\circ\text{C}$ (mW/°C)	POWER RATING $T_A = 85^\circ\text{C}$ (mW)
SOIC	Low-K	719	139	7	288
	High-K	840	119	8	336
MSOP	Low-K	469	213	5	188
	High-K	527	189	5	211

THERMAL CHARACTERISTICS

over operating free-air temperature range (unless otherwise noted)

PARAMETER		MIN	TYP	MAX	UNIT
θ_{JB}	Junction-to-board thermal resistance	SOIC	79		°C/W
		MSOP	120		
θ_{JC}	Junction-to-case thermal resistance	SOIC	98		°C/W
		MSOP	74		

KEY ATTRIBUTES

CHARACTERISTICS	PARAMETER	VALUE
Moisture sensitivity level		Level 1
Flammability rating (oxygen index: 28 to 34)		UL 94 V-0 at 0.125 in
Internal pull down resistor		50 K Ω
Electrostatic discharge	Human body model	2 KV
	Charged-device model	1.5 KV
	Machine model	200 V
Meets or exceeds JEDEC Spec EIA/JESD78 latchup test		

PECL INPUT DC CHARACTERISTICS

At $V_{CC} = 5.0\text{ V}$, $GND = 0.0\text{ V}$ (unless otherwise noted)⁽¹⁾⁽²⁾

PARAMETER	TEST CONDITIONS	$T_A = -40^\circ\text{C}$			$T_A = 25^\circ\text{C}$			$T_A = 85^\circ\text{C}$			UNIT
		MIN	TYP	MAX	MIN	TYP	MAX	MIN	TYP	MAX	
V_{IH}	High-level input voltage, single-ended	See ⁽³⁾			3835	4120	3835	4120	3835	4120	mV
V_{IL}	Low-level input voltage, single-ended	3190	2280	3525	3190	2280	3525	3190	2280	3525	mV
V_{IHCMR}	High-level input voltage common-mode range, differential	See ⁽⁴⁾			2.2	5.0	2.2	5.0	2.2	5.0	V
I_{IH}	High-level input current				255			175			μA
I_{IL}	Low-level input current	0.5			0.5			0.5			μA

- (1) The device meets the specifications after thermal balance has been established when mounted in a socket or printed circuit board with maintained transverse airflow greater than 500 lfm. Electrical parameters are assured only over the declared operating temperature range. Functional operation of the device exceeding these conditions is not implied. Device specification limit values are applied individually under normal operating conditions and not valid simultaneously.
- (2) Input and output parameters vary 1:1 with V_{CC} . V_{CC} can vary $\pm 0.25\text{ V}$.
- (3) TTL output $R_L = 500\ \Omega$ to GND
- (4) $V_{IHCMR(\min)}$ varies 1:1 with GND, $V_{IHCMR(\max)}$ varies 1:1 with V_{CC} .

TTL OUTPUT DC CHARACTERISTICS

At $V_{CC} = 4.75\text{ V}$ to 5.25 V , $T_A = -40^\circ\text{C}$ to 85°C (unless otherwise noted)⁽¹⁾

PARAMETER	TEST CONDITIONS	MIN	TYP	MAX	UNIT
I_{CCH}	Power supply current		20	25	mA
I_{CCL}	Power supply current		21	27	mA
I_{OS}	Output short circuit current	-150		-50	mA
V_{OH}	High-level output voltage ⁽²⁾	$I_{OH} = -3.0\text{ mA}$		$V_{CC} - 0.7\text{ V}$	V
V_{OL}	Low-level output voltage	$I_{OL} = 24\text{ mA}$		0.5	V

- (1) The device meets the specifications after thermal balance has been established when mounted in a socket or printed circuit board with maintained transverse airflow greater than 500 lfm. Electrical parameters are assured only over the declared operating temperature range. Functional operation of the device exceeding these conditions is not implied. Device specification limit values are applied individually under normal operating conditions and not valid simultaneously.
- (2) Max level is assured by design

AC CHARACTERISTICS

At $V_{CC} = 5.0\text{ V}$, $GND = 0.0\text{ V}$ (unless otherwise noted)⁽¹⁾⁽²⁾⁽³⁾

PARAMETER	TEST CONDITIONS	$T_A = -40^\circ\text{C}$			$T_A = 25^\circ\text{C}$			$T_A = 85^\circ\text{C}$			UNIT	
		MIN	TYP	MAX	MIN	TYP	MAX	MIN	TYP	MAX		
f_{MAX}	Max switching frequency	at $V_{ol} < 0.5\text{ V}$ and $V_{oh} > 2.4\text{ V}$ (see Figure 5)			250			250			MHz	
$t_{\text{PLH}}/t_{\text{PHL}}$	Propagation delay times to output	2.0	3.5	5.0	2.0	3.7	5.0	2.0	3.9	5.0	ns	
t_{JITTER}	Random clock jitter (RMS)	4.1			10			3.7			10	ps
V_{PP}	Input voltage swing ⁽⁴⁾	200			1000			200			1000	mV
t_r/t_f	Output rise times (10%–90%)	1.0	1.7	3.0	1.0	1.8	3.0	1.0	1.9	3.0	ns	
	Output fall times (10%–90%)	0.5	1.0	1.6	0.5	1.1	1.6	0.5	1.3	1.6		

- (1) The device meets the specifications after thermal balance has been established when mounted in a socket or printed circuit board with maintained transverse airflow greater than 500 lfm. Electrical parameters are assured only over the declared operating temperature range. Functional operation of the device exceeding these conditions is not implied. Device specification limit values are applied individually under normal operating conditions and not valid simultaneously.
- (2) V_{CC} can vary $\pm 0.25\text{ V}$.
- (3) TTL output $R_L = 500\ \Omega$ to GND and $C_L = 20\text{ pF}$ to GND, see Figure 1.
- (4) $V_{\text{PP}(\min)}$ is the minimum input swing for which AC parameters are assured.

Typical Output Loading Used for Device Evaluation

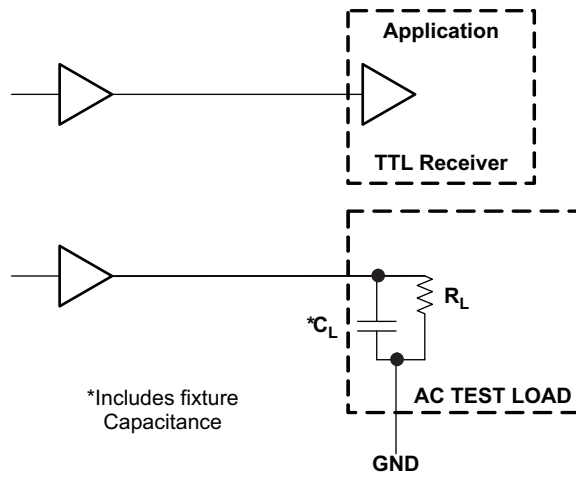

Figure 1. TTL Output Loading Used for Device Evaluation



Figure 2. Output Rise and Fall Times

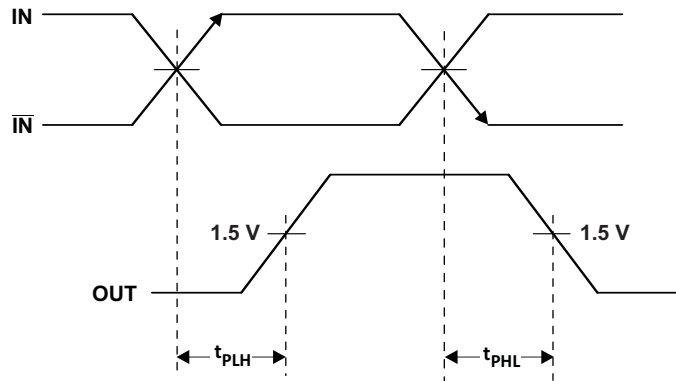

Figure 3. Output Propagation Delay

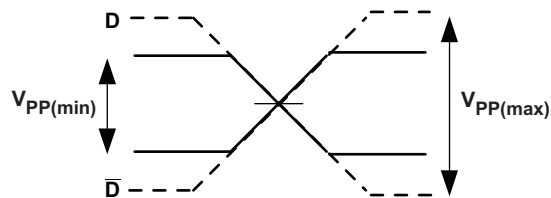

Figure 4. Input Voltage Swing

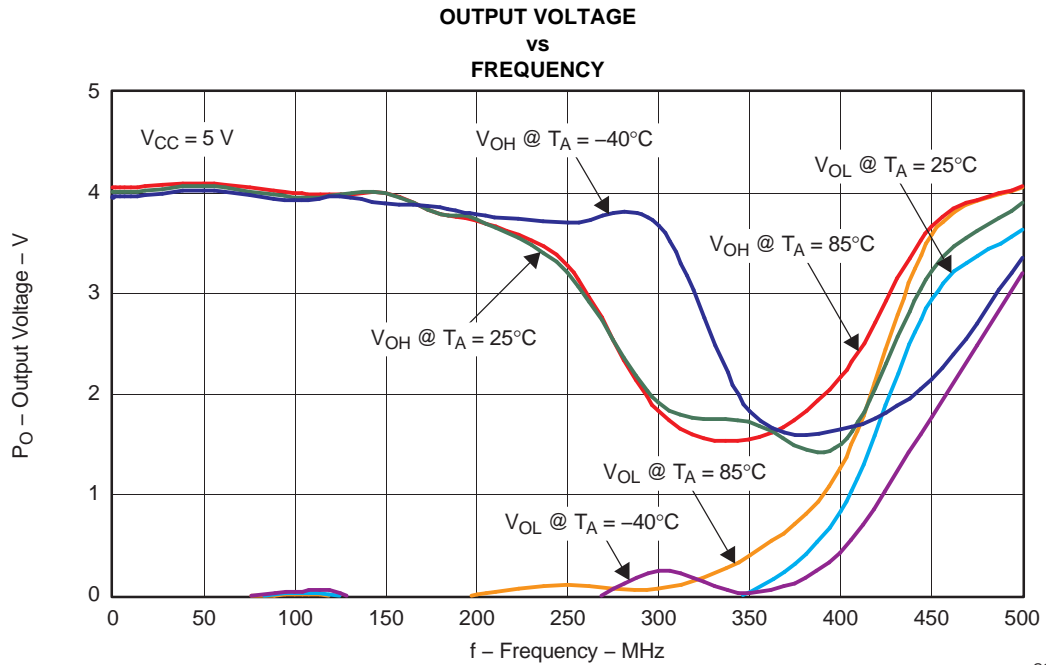

Figure 5.

G001

PACKAGING INFORMATION

Orderable Device	Status ⁽¹⁾	Package Type	Package Drawing	Pins	Package Qty	Eco Plan ⁽²⁾	Lead/Ball Finish	MSL Peak Temp ⁽³⁾
SN65ELT23D	ACTIVE	SOIC	D	8	75	Green (RoHS & no Sb/Br)	CU NIPDAU	Level-1-260C-UNLIM
SN65ELT23DGK	ACTIVE	MSOP	DGK	8	80	Green (RoHS & no Sb/Br)	CU NIPDAU	Level-1-260C-UNLIM
SN65ELT23DGKR	ACTIVE	MSOP	DGK	8	2500	Green (RoHS & no Sb/Br)	CU NIPDAU	Level-1-260C-UNLIM
SN65ELT23DR	ACTIVE	SOIC	D	8	2500	Green (RoHS & no Sb/Br)	CU NIPDAU	Level-1-260C-UNLIM

⁽¹⁾ The marketing status values are defined as follows:

ACTIVE: Product device recommended for new designs.

LIFEBUY: TI has announced that the device will be discontinued, and a lifetime-buy period is in effect.

NRND: Not recommended for new designs. Device is in production to support existing customers, but TI does not recommend using this part in a new design.

PREVIEW: Device has been announced but is not in production. Samples may or may not be available.

OBSOLETE: TI has discontinued the production of the device.

⁽²⁾ Eco Plan - The planned eco-friendly classification: Pb-Free (RoHS), Pb-Free (RoHS Exempt), or Green (RoHS & no Sb/Br) - please check <http://www.ti.com/productcontent> for the latest availability information and additional product content details.

TBD: The Pb-Free/Green conversion plan has not been defined.

Pb-Free (RoHS): TI's terms "Lead-Free" or "Pb-Free" mean semiconductor products that are compatible with the current RoHS requirements for all 6 substances, including the requirement that lead not exceed 0.1% by weight in homogeneous materials. Where designed to be soldered at high temperatures, TI Pb-Free products are suitable for use in specified lead-free processes.

Pb-Free (RoHS Exempt): This component has a RoHS exemption for either 1) lead-based flip-chip solder bumps used between the die and package, or 2) lead-based die adhesive used between the die and leadframe. The component is otherwise considered Pb-Free (RoHS compatible) as defined above.

Green (RoHS & no Sb/Br): TI defines "Green" to mean Pb-Free (RoHS compatible), and free of Bromine (Br) and Antimony (Sb) based flame retardants (Br or Sb do not exceed 0.1% by weight in homogeneous material)

⁽³⁾ MSL, Peak Temp. -- The Moisture Sensitivity Level rating according to the JEDEC industry standard classifications, and peak solder temperature.

Important Information and Disclaimer: The information provided on this page represents TI's knowledge and belief as of the date that it is provided. TI bases its knowledge and belief on information provided by third parties, and makes no representation or warranty as to the accuracy of such information. Efforts are underway to better integrate information from third parties. TI has taken and continues to take reasonable steps to provide representative and accurate information but may not have conducted destructive testing or chemical analysis on incoming materials and chemicals. TI and TI suppliers consider certain information to be proprietary, and thus CAS numbers and other limited information may not be available for release.

In no event shall TI's liability arising out of such information exceed the total purchase price of the TI part(s) at issue in this document sold by TI to Customer on an annual basis.

TAPE AND REEL INFORMATION



QUADRANT ASSIGNMENTS FOR PIN 1 ORIENTATION IN TAPE



*All dimensions are nominal

Device	Package Type	Package Drawing	Pins	SPQ	Reel Diameter (mm)	Reel Width W1 (mm)	A0 (mm)	B0 (mm)	K0 (mm)	P1 (mm)	W (mm)	Pin1 Quadrant
SN65ELT23DGKR	MSOP	DGK	8	2500	330.0	12.4	5.3	3.4	1.4	8.0	12.0	Q1
SN65ELT23DR	SOIC	D	8	2500	330.0	12.4	6.4	5.2	2.1	8.0	12.0	Q1

TAPE AND REEL BOX DIMENSIONS

*All dimensions are nominal

Device	Package Type	Package Drawing	Pins	SPQ	Length (mm)	Width (mm)	Height (mm)
SN65ELT23DGKR	MSOP	DGK	8	2500	346.0	346.0	29.0
SN65ELT23DR	SOIC	D	8	2500	346.0	346.0	29.0

DGK (S-PDSO-G8)

PLASTIC SMALL-OUTLINE PACKAGE



4073329/E 05/06

- NOTES:
- A. All linear dimensions are in millimeters.
 - B. This drawing is subject to change without notice.
 - C. Body length does not include mold flash, protrusions, or gate burrs. Mold flash, protrusions, or gate burrs shall not exceed 0.15 per end.
 - D. Body width does not include interlead flash. Interlead flash shall not exceed 0.50 per side.
 - E. Falls within JEDEC MO-187 variation AA, except interlead flash.

D (R-PDSO-G8)

PLASTIC SMALL OUTLINE



- NOTES:
- A. All linear dimensions are in inches (millimeters).
 - B. This drawing is subject to change without notice.
 - Body length does not include mold flash, protrusions, or gate burrs. Mold flash, protrusions, or gate burrs shall not exceed 0.006 (0,15) each side.
 - Body width does not include interlead flash. Interlead flash shall not exceed 0.017 (0,43) each side.
 - E. Reference JEDEC MS-012 variation AA.

D (R-PDSO-G8)

PLASTIC SMALL OUTLINE

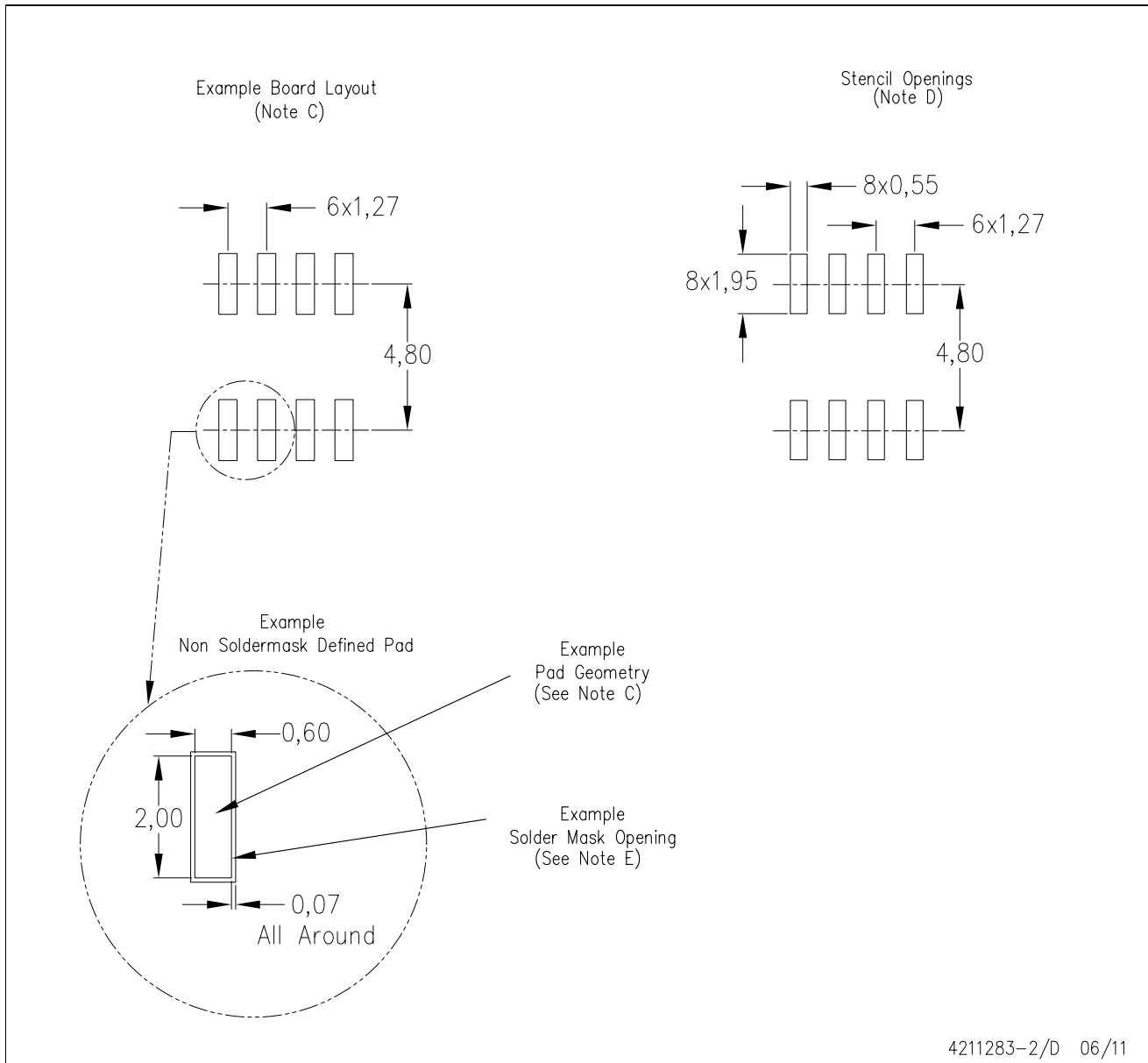

- NOTES:
- All linear dimensions are in millimeters.
 - This drawing is subject to change without notice.
 - Publication IPC-7351 is recommended for alternate designs.
 - Laser cutting apertures with trapezoidal walls and also rounding corners will offer better paste release. Customers should contact their board assembly site for stencil design recommendations. Refer to IPC-7525 for other stencil recommendations.
 - Customers should contact their board fabrication site for solder mask tolerances between and around signal pads.

IMPORTANT NOTICE

Texas Instruments Incorporated and its subsidiaries (TI) reserve the right to make corrections, modifications, enhancements, improvements, and other changes to its products and services at any time and to discontinue any product or service without notice. Customers should obtain the latest relevant information before placing orders and should verify that such information is current and complete. All products are sold subject to TI's terms and conditions of sale supplied at the time of order acknowledgment.

TI warrants performance of its hardware products to the specifications applicable at the time of sale in accordance with TI's standard warranty. Testing and other quality control techniques are used to the extent TI deems necessary to support this warranty. Except where mandated by government requirements, testing of all parameters of each product is not necessarily performed.

TI assumes no liability for applications assistance or customer product design. Customers are responsible for their products and applications using TI components. To minimize the risks associated with customer products and applications, customers should provide adequate design and operating safeguards.

TI does not warrant or represent that any license, either express or implied, is granted under any TI patent right, copyright, mask work right, or other TI intellectual property right relating to any combination, machine, or process in which TI products or services are used. Information published by TI regarding third-party products or services does not constitute a license from TI to use such products or services or a warranty or endorsement thereof. Use of such information may require a license from a third party under the patents or other intellectual property of the third party, or a license from TI under the patents or other intellectual property of TI.

Reproduction of TI information in TI data books or data sheets is permissible only if reproduction is without alteration and is accompanied by all associated warranties, conditions, limitations, and notices. Reproduction of this information with alteration is an unfair and deceptive business practice. TI is not responsible or liable for such altered documentation. Information of third parties may be subject to additional restrictions.

Resale of TI products or services with statements different from or beyond the parameters stated by TI for that product or service voids all express and any implied warranties for the associated TI product or service and is an unfair and deceptive business practice. TI is not responsible or liable for any such statements.

TI products are not authorized for use in safety-critical applications (such as life support) where a failure of the TI product would reasonably be expected to cause severe personal injury or death, unless officers of the parties have executed an agreement specifically governing such use. Buyers represent that they have all necessary expertise in the safety and regulatory ramifications of their applications, and acknowledge and agree that they are solely responsible for all legal, regulatory and safety-related requirements concerning their products and any use of TI products in such safety-critical applications, notwithstanding any applications-related information or support that may be provided by TI. Further, Buyers must fully indemnify TI and its representatives against any damages arising out of the use of TI products in such safety-critical applications.

TI products are neither designed nor intended for use in military/aerospace applications or environments unless the TI products are specifically designated by TI as military-grade or "enhanced plastic." Only products designated by TI as military-grade meet military specifications. Buyers acknowledge and agree that any such use of TI products which TI has not designated as military-grade is solely at the Buyer's risk, and that they are solely responsible for compliance with all legal and regulatory requirements in connection with such use.

TI products are neither designed nor intended for use in automotive applications or environments unless the specific TI products are designated by TI as compliant with ISO/TS 16949 requirements. Buyers acknowledge and agree that, if they use any non-designated products in automotive applications, TI will not be responsible for any failure to meet such requirements.

Following are URLs where you can obtain information on other Texas Instruments products and application solutions:

Products

Audio	www.ti.com/audio
Amplifiers	amplifier.ti.com
Data Converters	dataconverter.ti.com
DLP® Products	www.dlp.com
DSP	dsp.ti.com
Clocks and Timers	www.ti.com/clocks
Interface	interface.ti.com
Logic	logic.ti.com
Power Mgmt	power.ti.com
Microcontrollers	microcontroller.ti.com
RFID	www.ti-rfid.com
RF/IF and ZigBee® Solutions	www.ti.com/lprf

Applications

Communications and Telecom	www.ti.com/communications
Computers and Peripherals	www.ti.com/computers
Consumer Electronics	www.ti.com/consumer-apps
Energy and Lighting	www.ti.com/energy
Industrial	www.ti.com/industrial
Medical	www.ti.com/medical
Security	www.ti.com/security
Space, Avionics and Defense	www.ti.com/space-avionics-defense
Transportation and Automotive	www.ti.com/automotive
Video and Imaging	www.ti.com/video
Wireless	www.ti.com/wireless-apps

TI E2E Community Home Page

e2e.ti.com

Mailing Address: Texas Instruments, Post Office Box 655303, Dallas, Texas 75265
Copyright © 2011, Texas Instruments Incorporated