

Messrs.					
Product Specification	Model:	NMTG-F32240JFWHSCW-A	Revision No.	Issued Date.	Page.
			1	Jan. 12, 07	1

LIQUID CRYSTAL DISPLAY MODULE
MODEL: NMTG-F32240JFWHSCW-A
Customer's No.:

Acceptance

Microtips Technology Inc.
 12F. No.31 Lane 169, Kang Ning St., His-Chih,
 Taipei Hsien, Taiwan, R.O.C.
 FAX: 886-2-26958625

Approved and Checked by

Approved by	Checked by		Made by
			



Microtips Technology Inc.

Messrs.					
Product Specification	Model:	NMTG-F32240JFWHSCW-A	Revision No.	Issued Date.	Page.
			<i>1</i>	<i>Jan. 12, 07</i>	<i>2</i>

Revise Records

Rev.	Date	Contents	Written	Approved
A	2007/1/12	Initial Release	Sherry Chen	Aron Jau

Special notes

Note1.	The LCD module is compliant with RoHS
Note2.	
Note3.	
Note4.	
Note5.	

Messrs.					
Product Specification	Model:	NMTG-F32240JFWHSCW-A	Revision No.	Issued Date.	Page.
			<i>1</i>	<i>Jan. 12, 07</i>	<i>3</i>

CONTENTS

1.	General Specifications	4
2.	Electrical Specifications	5
3.	Lighting Specifications	9
4.	Optical Specifications	10
5.	Terminal	12
6.	Reliability Test	15
7.	Appearance Standards	16
8.	Handling and Precautions.....	17
9.	Warranty	18
10.	Dimensional Outlines	21



Microtips Technology Inc.

Messrs.					
Product Specification	Model:	NMTG-F32240JFWHSCW-A	Revision No.	Issued Date.	Page.
			<i>1</i>	<i>Jan. 12, 07</i>	<i>4</i>

1. General Specifications

Operating Temperature	:	Min. 0°C ~ Max. 50°C
Storage Temperature	:	Min. -20°C ~ Max. 70°C
Dot Pixels	:	320 (W) x 240 (H) dots
Dot Size	:	0.34 (W) x 0.34 (H) mm
Dot Pitch	:	0.36 (W) x 0.36 (H) mm
Viewing Area	:	122.0 (W) x 92.0 (H) mm
Outline Dimensions	:	167.1 (W) x 109.0 (H) x 11.0 max. (D) mm
		* Without Connector Cable
		** Without CCFL Cable
Weight	:	N/A
LCD Type	:	F-STN/ Positive-mode / Transflective
Viewing Angle	:	6:00
Data Transfer	:	4-bit parallel data input from LCD controller
Backlight	:	CCFL (White)
Additional Spec.	:	Holder and FPC ground are connected by soldering
Drawings	:	As attached drawings

Messrs.					
Product Specification	Model:	NMTG-F32240JFWHSCW-A	Revision No.	Issued Date.	Page.
			1	Jan. 12, 07	5

2. Electrical Specifications

2.1 Absolute Maximum Ratings

$V_{SS} = 0V$

Parameter	Symbol	Conditions	Min.	Max.	Units
Supply Voltage (Logic)	$V_{DD} - V_{SS}$	–	-0.3	7.0	V
Supply Voltage (LCD Drive)	$V_{LCD} - V_{SS}$	–	-0.3	30.0	V
Input Voltage	V_I	–	-0.3	$V_{DD} + 0.3$	V

2.2 DC Characteristics

$T_a = 25^\circ C, V_{SS} = 0V$

Parameter	Symbol	Conditions	Min.	Typ.	Max.	Units
Supply Voltage (Logic)	$V_{DD} - V_{SS}$	–	2.5	3.3	5.5	V
Supply Voltage (LCD Drive)	$V_{DD} - V_{EE}$	--	15.0	--	30.0	V
	$V_{DD} - V_{ADJ}$	Shown in 3.1				V
High Level Input Voltage	V_{IH}	$V_{DD} = 3.0V \pm 10\%$	$0.8 \times V_{DD}$	–	V_{DD}	V
Low Level Input Voltage	V_{IL}	$V_{DD} = 3.0V \pm 10\%$	--	–	$0.2 \times V_{DD}$	V
High Level Output Voltage	V_{OH}	$I_{OH} = -0.4mA$	$V_{DD} - 0.4$	–	--	V
Supply Current	I_{DD}	$V_{DD} - V_{SS} = 3.0V$	–	2.0	12.0	mA
	I_{EE}	$V_{DD} - V_{ADJ} = V$	–	1.5	--	mA
Frame	f_F	Duty = 50%	65	70	75	Hz

Note:

- $V_{DD} = +5.0V, V_0 = +30V, V_I = V_{SS}$
- $V_{DD} = +5.0V, V_0 = +30V, f_{XCK} = 20MHz, \text{No-load}, EI = V_{DD}$
The input data is turned over by the data taking clock (4-bit Parallel input mode)
- $V_{DD} = +5.0V, V_0 = +30V, f_{XCK} = 20MHz, \text{No-load}, EI = V_{SS}$
The input data is turned over by the data taking clock (4-bit parallel input mode)
- $V_{DD} = +5.0V, V_0 = +30V, f_{XCK} = 20MHz, f_{LP} = 41.6kHz, f_{FR} = 80 \text{ Hz}, \text{No-load}$
The input data is turned over by the data taking clock (4-bit parallel-input mode)



Microtips Technology Inc.

Messrs.					
Product Specification	Model:	NMTG-F32240JFWHSCW-A	Revision No.	Issued Date.	Page.
			1	Jan. 12, 07	6

2.3 Signal Timing Diagram

$V_{SS}=V_5=0V$, $V_{DD}= 3.0\sim 4.5V$, $V_0=15$ to $30 V$, and $T_A=-20$ to $+85^\circ C$

Parameter	Symbol	Min.	Max.	Units	Condition
Shift clock period	t_{WLP}	250	--	ns	$t_r, t_f \leq 20ns$
Shift clock "H" pulse width	t_{WCKH}	30	--	ns	$V_{DD}=+2.5\sim +4.5V$
Shift clock "L" pulse width	t_{WCKL}	51	--	ns	
Input signal rise time	t_r	--	50	ns	
Input signal fall time	t_f	--	50	ns	
Data setup time	t_{DS}	30	--	ns	
Data hold time	t_{DH}	50	--	ns	
Shift clock rise to latch pulse rise time	t_{LD}	0	--	ns	
Latch pulse rise to shift clock rise time	t_{LS}	51	--	ns	
Latch pulse fall to shift clock fall time	t_{LH}	51	--	ns	
FLM set-up time	t_{FSU}				
FLM hold time	t_{FH}				

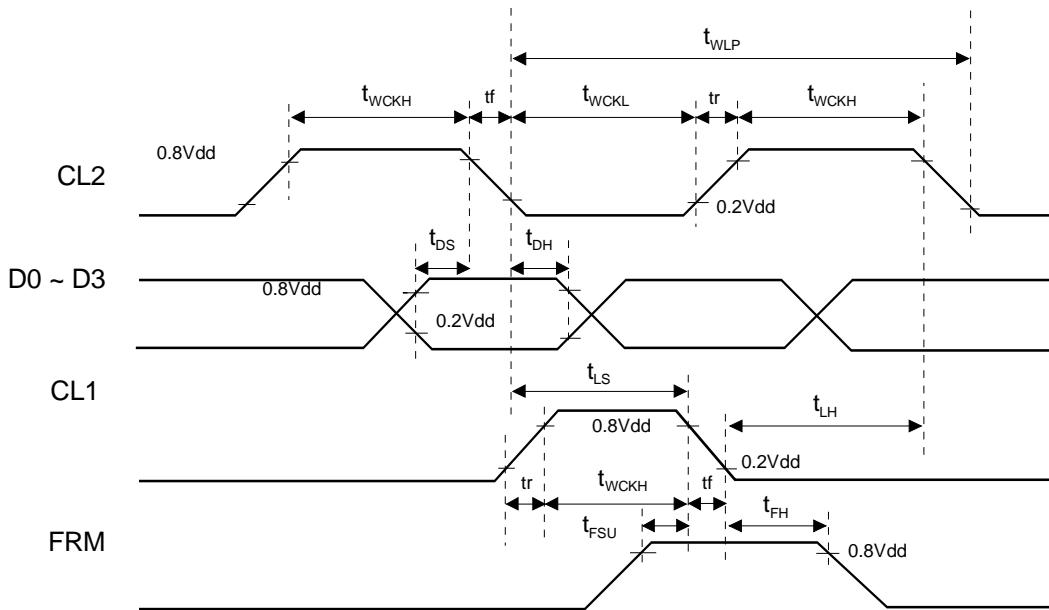

Signal Timing(1)

2.4 Timing Chart & Comparison of Display and Data

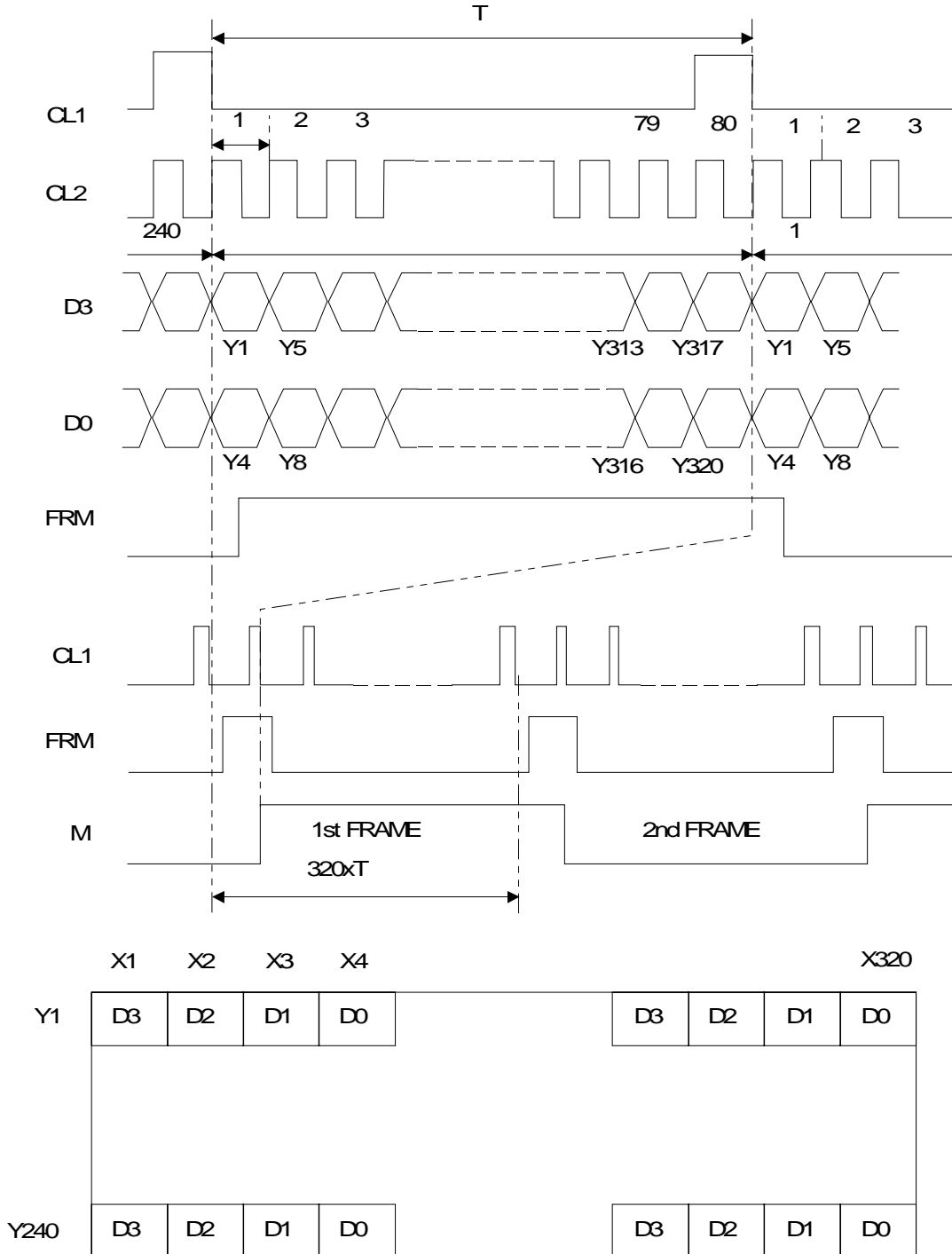

Signal Timing (2)



Messrs.					
Product Specification	Model:	NMTG-F32240JFWHSCW-A	Revision No.	Issued Date.	Page.
			1	Jan. 12, 07	8

2.5 Power Supply ON/OFF Sequence

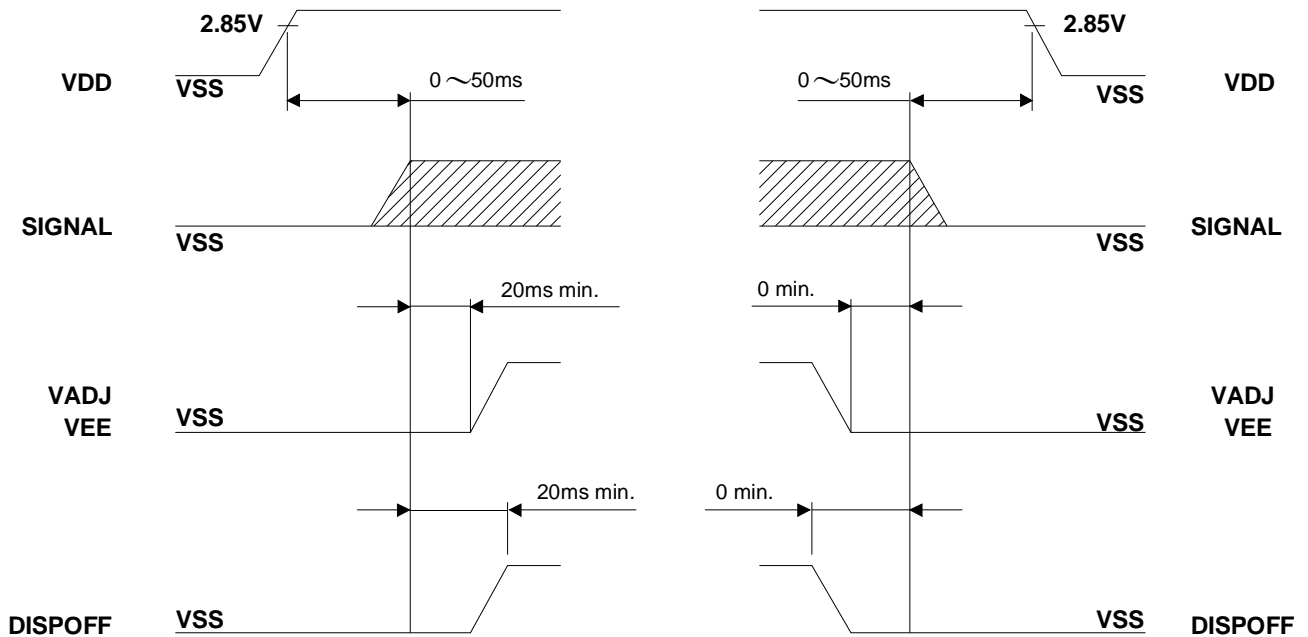

The missing pixels may occur when the LCM is driver beyond above power interface timing sequence.

Messrs.					
Product Specification	Model:	NMTG-F32240JFWHSCW-A	Revision No.	Issued Date.	Page.
			1	Jan. 12, 07	9

3. Lighting Specifications

3.1 Spec. for CCFL back-light

Ta = 25 °C

Parameter	Symbol	Conditions	Min.	Typ.	Max.	Units	Notes
Lamp Voltage	V _L	IL=5mA	230	280	330	Vrms	1)
Lamp Current	I _L	—	4.3	4.8	5.3	mArms	2)
Starting Voltage	V _S	Ta=25°C	—	—	270	Vrms	3)
		Ta = 0°C	—	—	680	Vrms	3)
Surface Luminance	L	IL=5mA	—	--	855	cd/m ²	4)
Average Life	T _{AL}	IL=5mA	--	17000	—	hrs	5)

Note 1). The voltage (r.m.s.) to maintain the electric discharge of the lamp. It is measured after lighting for 3 minutes .

Note 2). The current (r.m.s.) to flow through the lamp with the electric discharge. It is measured after lighting for 3 minutes.

Note 3). The voltage at starting the electric discharge when the voltage is increased gradually from 0V.

Note 4). Surface Luminance is specified by the initial data of luminance measured at the center of display surface after 20 minutes power on. (All ON pattern)

Note 5). CFL life is defined as the time for which the initial luminance is attenuated by 50% of the luminance value. Average Life represents the time elapsed at the point of time when the residual ratio becomes below 50% when plural lamps are lighted in comparison with the definition of life mentioned above.

Messrs.					
Product Specification	Model:	NMTG-F32240JFWHSCW-A	Revision No.	Issued Date.	Page.
			1	Jan. 12, 07	10

4. Optical Specifications

4.1 LCD Driving Voltage

Parameter	Symbol	Conditions	Min.	Typ.	Max.	Units
Recommended LCD Driving Voltage Note 1		Ta = -20 °C	27.2	28.0	28.8	V
		Ta = 0 °C	--	--	--	V
		Ta = 25 °C	23.8	24.5	25.2	V
		Ta = 50 °C	--	--	--	V
		Ta = 70 °C	21.7	22.4	23.1	V

Note 1 : Voltage (Applied actual waveform to LCD Module) for the best contrast. The range of minimum and maximum shows tolerance of the operating voltage. The specified contrast ratio and response time are not guaranteed over the entire range.

4.2 Optical Characteristics

Ta=25 °C, 1/240 Duty, 1/17 Bias, V_{DD} = V (Note 4), θ = 0°, φ = 270°

Parameter	Symbol	Conditions	Min.	Typ.	Max.	Units
Contrast Ratio Note 1	CR	θF,B,R,L = 25~25°	--	7.2	--	
Viewing Angle		Shown in 3.3				
Response Time	Rise Note 2	T _{ON}	--	160	--	ms
	Decay Note 3	T _{OFF}	--	345	--	ms

Note 1 : Contrast ratio is defined as follows.

$$CR = L_{OFF} / L_{ON}$$

L_{ON} : Luminance of the ON segments, L_{OFF} : Luminance of the OFF segments

Note 2 : The time that the luminance level reaches 90% of the saturation level from 0% when ON signal is applied.

Note 3 : The time that the luminance level reaches 10% of the saturation level from 100% when OFF signal is applied.

Note 4 : Definition of Driving Voltage V_D. Assuming that the typical driving waveforms shown below are applied to the LCD Panel at 1/A Duty - 1/B Bias (A : Duty Number, B : Bias Number). Driving voltage V_D is defined as follows: $V_D = (V_{th1} + V_{th2}) / 2$

V_{th1} : The voltage VO-P that should provide 50% of the saturation level in the luminance at the segment which the ON signal is applied to.

V_{th2} : The voltage VO-P that should provide 50% of the saturation level in the luminance at the segment which the OFF signal is applied to.

Messrs.					
Product Specification	Model:	NMTG-F32240JFWHSCW-A	Revision No.	Issued Date.	Page.
			1	Jan. 12, 07	11

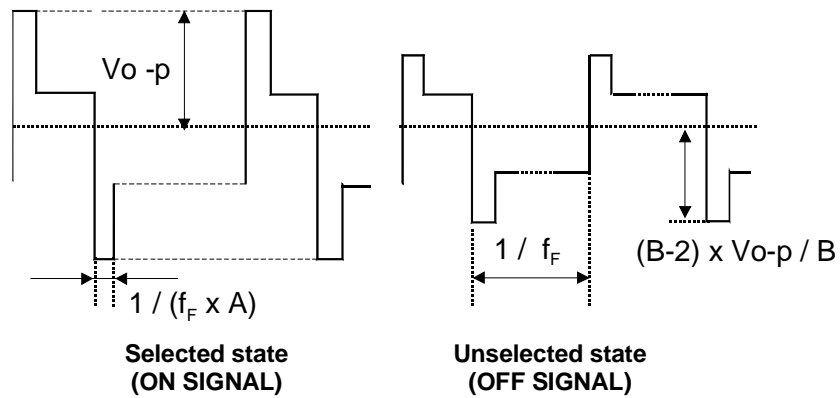

4.3 Definition of Viewing Angle and Optimum Viewing Area

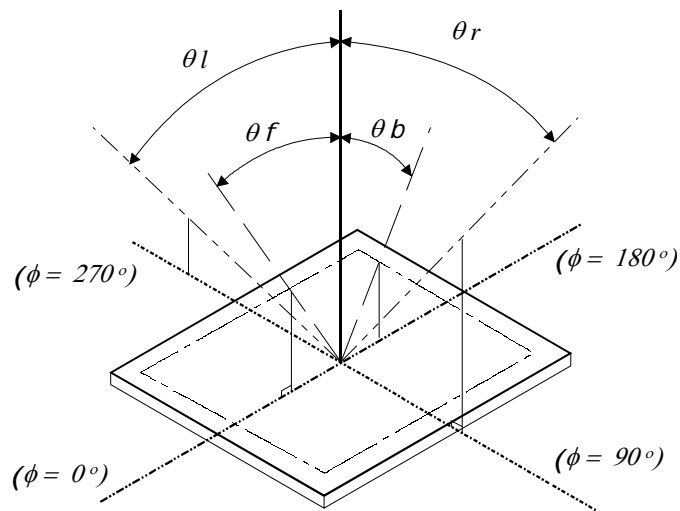

LCD panel

4.4 Definition of Viewing Angle θ_f and θ_b

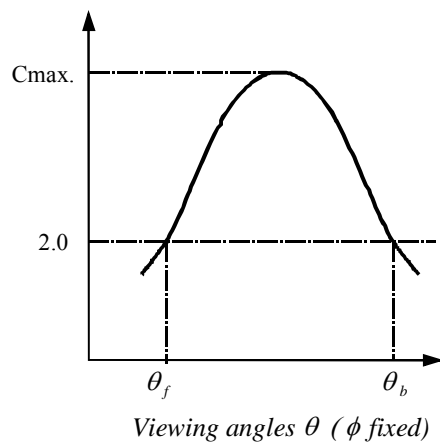

Optimum viewing angle with the naked eye and viewing angle θ at C_{max} .
Above are not always the same.

Messrs.					
Product Specification	Model:	NMTG-F32240JFWHSCW-A	Revision No.	Issued Date.	Page.
			1	Jan. 12, 07	12

4.5 Definition of Contrast C, $C = \text{Brightness of selected dot (B1)} / \text{Brightness of unselected dot (B2)}$

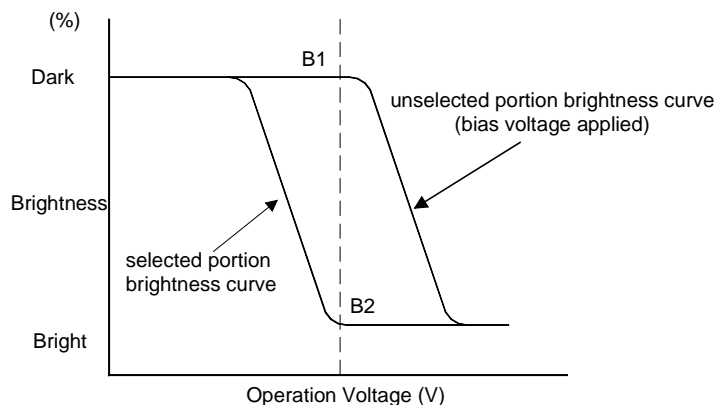

5. Terminal

5.1 Pin Assignment

LCD (CN1)

Pin No.	Symbol	Level	Function
1	D0	--	Display data
2	D1	--	Display data
3	D2	--	Display data
4	D3	--	Display data
5	/DISPOFF		H:Display On L:Display Off
6	FLM	--	Scan Start-Up Signal
7	M (N/C)	--	Not Connector
8	CL1 (LP)	--	Latch pulse input/shift clock input for shift register
9	CL2 (SCP)	--	Display data shift clock input for segment mode
10	V _{DD}	--	Power supply for logic system (+2.5 to + 5.5 V)
11	V _{SS}	--	Ground pin connects to 0V
12	V _{EE}	--	Power supply for LCD drive (+V)
13	V0		Power supply for LCD Adjust
14	FGND		Frame ground

CCFL (CN2)

Pin No.	Symbol	Level	Function
1	CCFL HOT	--	Power Supply for CCFL (HOT)
2	NC	--	Non-connection
3	NC	--	Non-connection
4	CCFL GND	--	Power Supply for CCFL (GND)

Messrs.					
Product Specification	Model:	NMTG-F32240JFWHSCW-A	Revision No.	Issued Date.	Page.
			1	Jan. 12, 07	13

5.2 Example of Power Supply

It is recommended to apply a potentiometer for the contrast adjust due to the tolerance of the driving voltage and its temperature dependence.

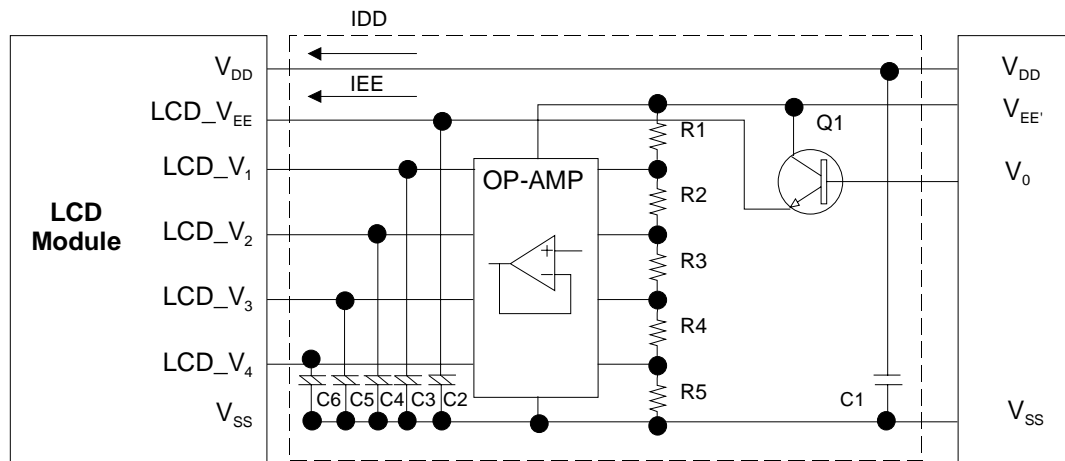

Q1: 2SC1815

OP-AMP: LP324

$R1=R2=R4=R4=22$, $R3=9R1=200$ K Ω (1/13 Bias)

$C1=0.1\mu\text{F}$, $C2\sim C6=3.3\mu\text{F}$

$V_{DD}=3.0\text{V}$, $V_{EE}=+24\text{V}$, $V_{EE}'>V_0>V_{SS}$

Note 1: These are general values.

In case to decrease LCD driving voltage with minimizing bias value, set these value with check display to avoid display's deterioration (response etc.)

Note 2: EL Driving Method.

- Contrast voltage source driving: AC100 Vrms, 400Hz
- Inverter IC Driving: SP4423 (Sipex) or HV823 (Supertex)

Messrs.					
Product Specification	Model:	NMTG-F32240JFWHSCW-A	Revision No.	Issued Date.	Page.
			1	Jan. 12, 07	14

5.3 Block Diagram

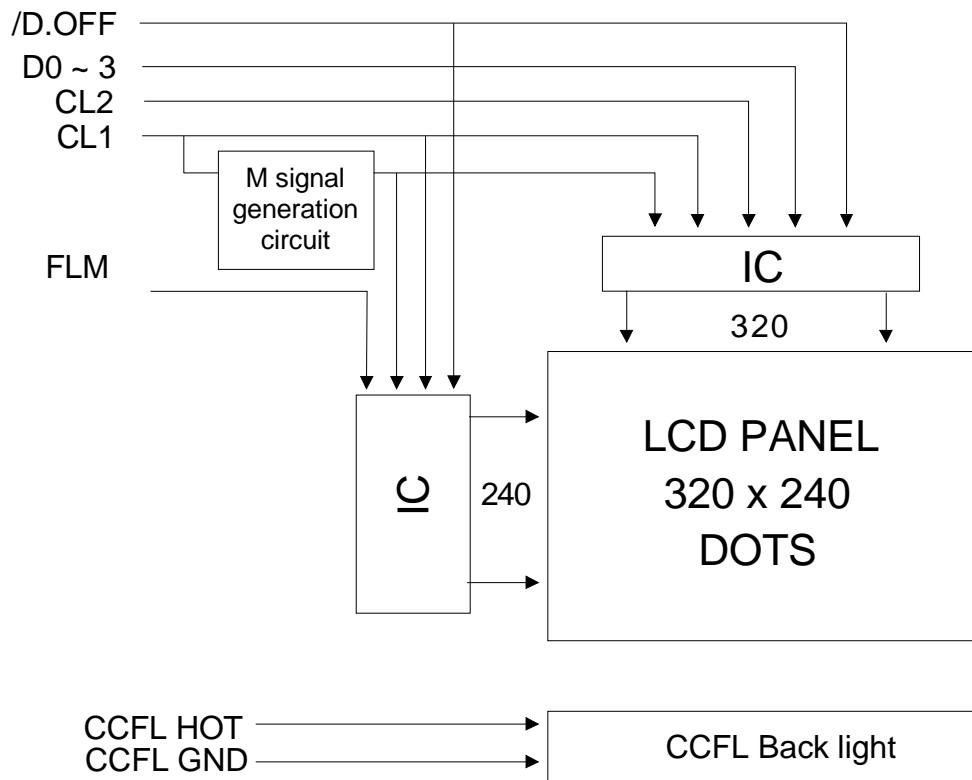

Messrs.					
Product Specification	Model:	NMTG-F32240JFWHSCW-A	Revision No.	Issued Date.	Page.
			1	Jan. 12, 07	15

6. Reliability Test

6.1 Test Item

No change on display and in operation under the following test condition.

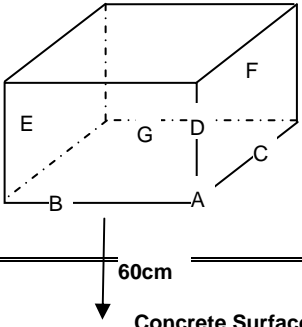
No.	Test Item	Description	Condition	Note
1.	High Temperature (Operation)	Durability test under long time high temperature with electrical stress (voltage, current)	50°C ± 2°C 96hrs	
2.	High Temperature (Storage)	Durability test under long time high temperature storage	60°C ± 2°C 96hrs	4
3	Low Temperature (Operation)	Durability test under long time low temperature with electrical stress (voltage, current)	0°C ± 2°C, 96hrs	3
4	Low Temperature (Storage)	Durability test under long time low temperature storage	-20°C ± 2°C, 96hrs	3, 4
5	Damp Proof Test	Durability test under long time high temperature and high humidity	40°C ± 2°C, 90~95% RH 96hrs	3, 4
6.	Vibration Test	Total fixed amplitude: 1.5mm Vibration frequency: 10~55Hz One cycle 60 seconds to 3 directions of X, Y, Z for each 15 minutes	--	5
7.	Shock Test	To be measured after dropping from 60cm high on the concrete surface in packing state.  Dropping method corner dropping A corner: once Edge dropping B, C, D edge: once Face dropping E, F, G face: once		

Messrs.					
Product Specification	Model:	NMTG-F32240JFWHSCW-A	Revision No.	Issued Date.	Page.
			1	Jan. 12, 07	16

--	--	--	--

Note 1: Unless otherwise specified, tests will be conducted under the following condition,

Temperature : 25°C ± 2°C

Humidity : 65% ± 5%

Note 2: Unless otherwise specified, tests will be not conducted under functioning state.

Note 3: No dew condensation to be observed.

Note 4: The function test shall be conducted after 4 hours storage at the normal temperature and humidity after removed from the test chamber.

Note 5: Vibration test will be conducted to the product itself without putting it in a container.

6.2 Judgment Standard

Failure Mode	Test Item							Judgment Standard
	1	2	3	4	5	6	7	
Orientation	*	*	*	*	*			No remarkable degradation of appearance under bias/ non-bias condition
Current Value (IAC)	*	*	*	*	*			No remarkable increase
Contrast	*		*	*	*			No remarkable poor contrast
Domain	*	*	*	*	*			Less than 20% of all dots have reverse tilt of more than on third of one dot area.
Bubble (Inside Cell)	*	*	*	*	*	*		As per "Appearance Standard" (Note. including one which disappear after 25°C 2H)
Polarizer	*				*	*		As per "Appearance Standard" no remarkable appearance change
Glass Damage							*	As per "Appearance Standard"

Note. 1. * is strong linkage between Failure Mode and Test Item.

2. Number of Test Item should be referred to former page.

3. Judgment and Standard value should be fixed by other inspection standard and criteria samples.

Messrs.					
Product Specification	Model:	NMTG-F32240JFWHSCW-A	Revision No.	Issued Date.	Page.
			1	Jan. 12, 07	17

7. Appearance Standards

7.1 Inspection Conditions

The LCD shall be inspected under 40W white fluorescent light.
The distance between the eyes and the sample shall be more than 30cm.
All directions for inspecting the sample should be within 45° against perpendicular line.

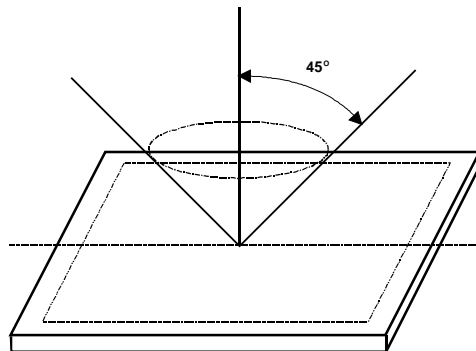

7.2 Definition of Applicable Zones

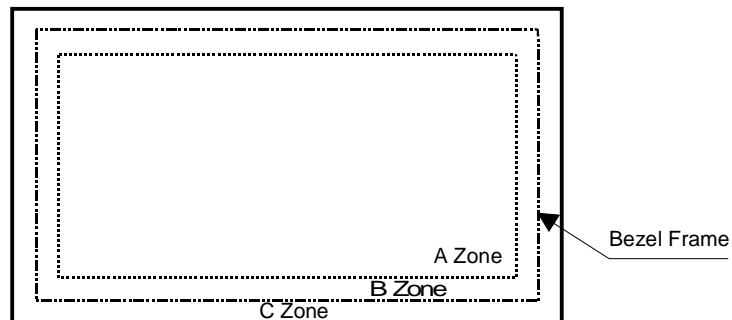

Messrs.					
Product Specification	Model:	NMTG-F32240JFWHSCW-A	Revision No.	Issued Date.	Page.
			1	Jan. 12, 07	18

A Zone : Active display area
 B Zone : Area from outside of "A Zone" to validity viewing area
 C Zone : Rest parts
 A Zone + B Zone = Validity viewing area

7.3 Standards

No.	Parameter	Criteria																																																									
1.	Black and White Spots, Foreign Substances	<p>(1) Round Shape</p> <table border="1"> <thead> <tr> <th rowspan="2">Dimension (mm) \ Zone</th> <th colspan="3">Acceptable Number</th> </tr> <tr> <th>A</th> <th>B</th> <th>C</th> </tr> </thead> <tbody> <tr> <td>D ≤ 0.1</td> <td>*</td> <td>*</td> <td>*</td> </tr> <tr> <td>0.1 < D ≤ 0.2</td> <td>3</td> <td>5</td> <td>*</td> </tr> <tr> <td>0.2 < D ≤ 0.25</td> <td>2</td> <td>3</td> <td>*</td> </tr> <tr> <td>0.25 < D ≤ 0.3</td> <td>0</td> <td>1</td> <td>*</td> </tr> <tr> <td>0.3 < D</td> <td>0</td> <td>0</td> <td>*</td> </tr> </tbody> </table> <p>D = (Long + Short)/2 * : Disregard</p> <p>(2) Line Shape</p> <table border="1"> <thead> <tr> <th colspan="2">X (mm) \ Y (mm) \ Zone</th> <th colspan="3">Acceptable Number</th> </tr> <tr> <th colspan="2"></th> <th>A</th> <th>B</th> <th>C</th> </tr> </thead> <tbody> <tr> <td>--</td> <td>0.03 ≥ W</td> <td>*</td> <td>*</td> <td>*</td> </tr> <tr> <td>2.0 ≥ L</td> <td>0.05 ≥ W</td> <td>4</td> <td>4</td> <td>*</td> </tr> <tr> <td>1.0 ≥ L</td> <td>0.1 ≥ W</td> <td>4</td> <td>4</td> <td>*</td> </tr> <tr> <td>--</td> <td>0.1 < W</td> <td colspan="3">In the same way (1)</td> </tr> </tbody> </table> <p>X : Length Y: Width * : Disregard Total defects shall not exceed 7.</p>	Dimension (mm) \ Zone	Acceptable Number			A	B	C	D ≤ 0.1	*	*	*	0.1 < D ≤ 0.2	3	5	*	0.2 < D ≤ 0.25	2	3	*	0.25 < D ≤ 0.3	0	1	*	0.3 < D	0	0	*	X (mm) \ Y (mm) \ Zone		Acceptable Number					A	B	C	--	0.03 ≥ W	*	*	*	2.0 ≥ L	0.05 ≥ W	4	4	*	1.0 ≥ L	0.1 ≥ W	4	4	*	--	0.1 < W	In the same way (1)		
Dimension (mm) \ Zone	Acceptable Number																																																										
	A	B	C																																																								
D ≤ 0.1	*	*	*																																																								
0.1 < D ≤ 0.2	3	5	*																																																								
0.2 < D ≤ 0.25	2	3	*																																																								
0.25 < D ≤ 0.3	0	1	*																																																								
0.3 < D	0	0	*																																																								
X (mm) \ Y (mm) \ Zone		Acceptable Number																																																									
		A	B	C																																																							
--	0.03 ≥ W	*	*	*																																																							
2.0 ≥ L	0.05 ≥ W	4	4	*																																																							
1.0 ≥ L	0.1 ≥ W	4	4	*																																																							
--	0.1 < W	In the same way (1)																																																									
2.	Air Bubbles (between glass & polarizer)	<table border="1"> <thead> <tr> <th rowspan="2">Dimension (mm) \ Zone</th> <th colspan="3">Acceptable Number</th> </tr> <tr> <th>A</th> <th>B</th> <th>C</th> </tr> </thead> <tbody> <tr> <td></td> <td></td> <td></td> <td></td> </tr> </tbody> </table>	Dimension (mm) \ Zone	Acceptable Number			A	B	C																																																		
Dimension (mm) \ Zone	Acceptable Number																																																										
	A	B	C																																																								

Messrs.					
Product Specification	Model:	NMTG-F32240JFWHSCW-A	Revision No.	Issued Date.	Page.
			1	Jan. 12, 07	19

		$D \leq 0.3$	*	*	*
		$0.3 < D \leq 0.4$	3	*	*
		$0.4 < D \leq 0.6$	2	3	*
		$0.6 < D$	0	0	*

*: Disregard
Total defects shall not exceed 3.

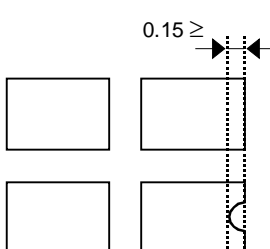
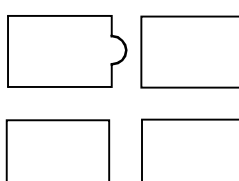
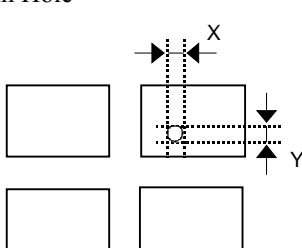
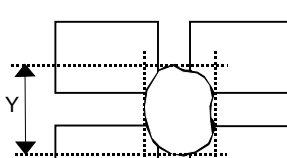
No.	Parameter	Criteria
3.	The Shape of Dot	<p>(1) Dot Shape (with Dent)</p>  <p>As per the sketch of left hand.</p> <p>(2) Dot Shape (with Projection)</p>  <p>Should not be connected to next dot.</p> <p>(3) Pin Hole</p>  <p>$(X+Y)/2 \leq 0.2\text{mm}$ (Less than 0.1mm is no counted.)</p> <p>(4) Deformation</p>  <p>$(X+Y)/2 \leq 0.2\text{mm}$</p>

Messrs.					
Product Specification	Model:	NMTG-F32240JFWHSCW-A	Revision No.	Issued Date.	Page.
			1	Jan. 12, 07	20

		Total acceptable number: 1/dot, 5/cell (Defect number of (4): 1pc.)
4.	Polarizer Scratches	Not to be conspicuous defects.
5.	Polarizer Dirts	If the stains are removed easily from LCDP surface, the module is not defective.
6.	Complex Foreign Substance Defects	Black spots, line shaped foreign substance or air bubbles between glass & polarizer should be 5pcs maximum in total.
7.	Distance between different Foreign Substance defects	$D \leq 0.2$: 20mm or more $0.2 < D$: 40mm or more

8. Handling and Precautions

The Following precautions will guide you in handling our product correctly.

- 1 Liquid crystal display devices
 - 1.1 The liquid crystal display device panel used in the liquid crystal display module is made of plate glass. Avoid any strong mechanical shock. Should the glass break handle it with care.
 - 1.2 The polarizer adhering to the surface of the LCD is made of a soft material. Guard against scratching it.
- 2 Care of the liquid crystal display module against static electricity discharge.
 - 2.1 When working with the module, be sure to ground your body and any electrical equipment you may be using. We strongly recommend the use of anti static mats (made of rubber), to protect work tables against the hazards of electrical shock.
 - 2.2 Avoid the use of work clothing made of synthetic fibers. We recommend cotton clothing or other conductivity-treated fibers.
 - 2.3 Slowly and carefully remove the protective film from the LCD module, since this operation can generate static electricity.
- 3 When the LCD module alone must be stored for long periods of time:
 - 3.1 Protect the modules from high temperature and humidity.
 - 3.2 Keep the modules out of direct sunlight or direct exposure to ultra-violet rays.
 - 3.3 Protect the modules from excessive external forces.
- 4 Use the module with a power supply that is equipped with an over current protector circuit, since the module is not provided with this protective feature.
- 5 Do not ingest the LCD fluid itself should it leak out of a damaged LCD module. Should hands or clothing come in contact with LCD fluid, wash immediately with soap.
- 6 Conductivity is not guaranteed for models that use metal holders where solder connections between the metal holder and the PCB are not used. Please contact us to discuss appropriate ways to assure conductivity.
- 7 For models which use CCFL:
 - 7.1 High voltage of 1000V or greater is applied to the CCFL cable connector area. Care should be taken not to touch connection areas to avoid burns.
 - 7.2 Protect CCFL cables from rubbing against the unit and thus causing the wire jacket to become worn.
 - 7.3 The use of CCFLs for extended periods of time at low temperatures will significantly shorten their service life.
- 8 For models which use touch panels:



Microtips Technology Inc.

Messrs.					
Product Specification	Model:	NMTG-F32240JFWHSCW-A	Revision No.	Issued Date.	Page.
			<i>1</i>	<i>Jan. 12, 07</i>	<i>21</i>

- 8.1 Do not stack up modules since they can be damaged by components on neighboring modules.
- 8.2 Do not place heavy objects on top of the product. This could cause glass breakage.

9 For models which use COG, TAB or COF:

- 9.1 The mechanical strength of the product is low since the IC chip faces out unprotected from the rear. Be sure to protect the rear of the IC chip from external forces.
- 9.2 Given the fact that the rear of the IC chip is left exposed, in order to protect the unit from electrical damage, avoid installation configurations in which the rear of the IC chip runs the risk of making any electrical contact.

10 Models which use flexible cable, heat seal, or TAB:

- 10.1 In order to maintain reliability, do not touch or hold by the connector area.
- 10.2 Avoid any bending, pulling, or other excessive force, which can result in broken connections.

9. Warranty

This product has been manufactured to your company's specifications as a part for use in your company's general electronic products. It is guaranteed to perform according to delivery specifications. For any other use apart from general electronic equipment, we cannot take responsibility if the product is used in medical devices, nuclear power control equipment, aerospace equipment, fire and security systems, or any other applications in which there is a direct risk to human life and where extremely high levels of reliability are required. If the product is to be used in any of the above applications, we will need to enter into a separate product liability agreement.

- 1 We cannot accept responsibility for any defect, which may arise from additional manufacturing of the product (including disassembly and reassembly), after product delivery.
- 2 We cannot accept responsibility for any defect, which may arise after the application of strong external force to the product.
- 3 We cannot accept responsibility for any defect, which may arise due to the application of static electricity after the product has passed your company's acceptance inspection procedures.
- 4 When the product is in CCFL models, CCFL service life and brightness will vary according to the performance of the inverter used, leaks, etc. We cannot accept responsibility for product performance, reliability, or defect, which may arise.
- 5 We cannot accept responsibility for industrial property, which may arise through the use of your product, with exception to those issues relating directly to the structure or method of manufacturing of our product. Microtips-origin longer than 2 (two) years from Microtips production or 1(one) year from Microtips overseas agent or distributor delivery which ever comes later.

10. Dimensional Outlines

- ◆ See the next page.....



Microtips Technology Inc.

Messrs.					
Product Specification	Model:	NMTG-F32240JFWHSCW-A	Revision No.	Issued Date.	Page.
			<i>1</i>	<i>Jan. 12, 07</i>	<i>22</i>



Microtips Technology Inc.

