

Ultra Low Power, Rail-to-Rail Output, Fully-Differential Amplifier

Check for Samples: [THS4531](#)

FEATURES

- **Ultra Low Power:**
 - Voltage: 2.5 V to 5.5 V
 - Current: 250 μ A
 - Power-Down Mode: 0.5 μ A (typ)
- **Fully-Differential Architecture**
- **Bandwidth: 36 MHz**
- **Slew Rate: 200 V/ μ s**
- **THD: –120 dBc at 1 kHz (1 V_{RMS} , $R_L = 2$ k Ω)**
- **Input Voltage Noise: 10 nV/ \sqrt{Hz} (f = 1 kHz)**
- **High DC Accuracy:**
 - V_{OS} Drift: ± 4 μ V/ $^{\circ}$ C (–40 $^{\circ}$ C to +125 $^{\circ}$ C)
 - A_{OL} : 114 dB
- **Rail-to-Rail Output (RRO)**
- **Negative Rail Input (NRI)**
- **Output Common-Mode Control**

APPLICATIONS

- **Low-Power SAR, $\Delta\Sigma$ ADC Driver**
- **Low Power, High Performance:**
 - Differential to Differential Amplifier
 - Single-Ended to Differential Amplifier
- **Low-Power, Wide-Bandwidth Differential Driver**
- **Low-Power, Wide-Bandwidth Differential Signal Conditioning**
- **High Channel Count and Power Dense Systems**

DESCRIPTION

The THS4531 is a low-power, fully-differential op amp with input common-mode range below the negative rail and rail-to-rail output. The device is designed for low-power data acquisition systems and high density applications where power consumption and dissipation is critical.

The device features accurate output common-mode control that allows for dc coupling when driving analog-to-digital converters (ADCs). This control, coupled with the input common-mode range below the negative rail and rail-to-rail output, allows for easy interface from single-ended ground-referenced signal sources to successive-approximation registers (SARs), and delta-sigma ($\Delta\Sigma$) ADCs using only single-supply 2.5-V to 5-V power. The THS4531 is also a valuable tool for general-purpose, low-power differential signal conditioning applications.

The THS4531 is characterized for operation over the extended industrial temperature range from –40 $^{\circ}$ C to +125 $^{\circ}$ C. The following package options are available:

- 8-pin SOIC (MSOP) and VSSOP (D and DGK)
- 10-pin WQFN (RUN)

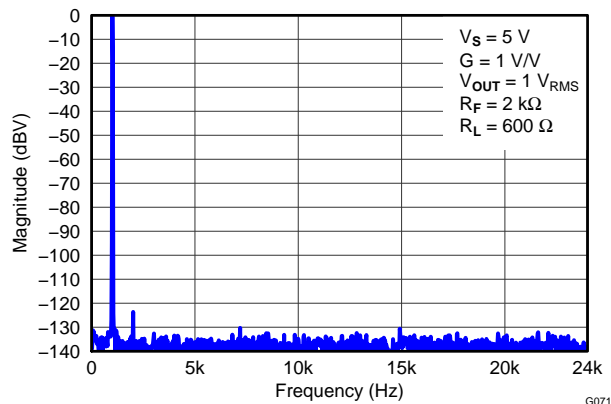

Figure 1. 1-kHz FFT Plot on Audio Analyzer

Table 1. Related Products

DEVICE	BW (MHz)	I_Q (mA)	THD (dBc) at 100 kHz	V_N (nV/ \sqrt{Hz})	RAIL-TO-RAIL
THS4521	145	1.14	–120	4.6	Out
THS4520	570	15.3	–114	2	Out
THS4121	100	16	–79	5.4	In/Out
THS4131	150	16	–107	1.3	No



Please be aware that an important notice concerning availability, standard warranty, and use in critical applications of Texas Instruments semiconductor products and disclaimers thereto appears at the end of this data sheet.



This integrated circuit can be damaged by ESD. Texas Instruments recommends that all integrated circuits be handled with appropriate precautions. Failure to observe proper handling and installation procedures can cause damage.

ESD damage can range from subtle performance degradation to complete device failure. Precision integrated circuits may be more susceptible to damage because very small parametric changes could cause the device not to meet its published specifications.

PACKAGING/ORDERING INFORMATION⁽¹⁾

PRODUCT	CHANNEL COUNT	PACKAGE-LEAD	PACKAGE DESIGNATOR	SPECIFIED TEMPERATURE RANGE	PACKAGE MARKING	ORDERING NUMBER	TRANSPORT MEDIA, QUANTITY
THS4531	1	SOIC-8	D	-40°C to +125°C	T4531	THS4531ID	Rails, 75
	1				T4531	THS4531IDR	Tape and reel, 2500
	1	VSSOP-8	DGK	-40°C to +125°C	4531	THS4531IDGK	Rails, 80
	1				4531	THS4531IDGKR	Tape and reel, 2500
	1	WQFN-10	RUN	-40°C to +125°C	4531	THS4531IRUNT	Tape and reel, 250
	1				4531	THS4531IRUNR	Tape and reel, 3000

(1) For the most current package and ordering information, see the Package Option Addendum at the end of this document, or see the TI web site at www.ti.com.

ABSOLUTE MAXIMUM RATINGS

	VALUE	UNITS	
Supply voltage, V_{S-} to V_{S+}	5.5		
Input/output voltage, $V_{IN±}$, $V_{OUT±}$, and V_{OCM} pins	$(V_{S-}) - 0.7$ to $(V_{S+}) + 0.7$	V	
Differential input voltage, V_{ID}	1	V	
Continuous output current, I_O	50	mA	
Continuous input current, I_i	0.75	mA	
Continuous power dissipation	See Thermal Information		
Maximum junction temperature, T_J	150	°C	
Operating free-air temperature range, T_A	-40 to +125	°C	
Storage temperature range, T_{stg}	-65 to +150	°C	
Electrostatic discharge (ESD) ratings:	Human body model (HBM)	3000	V
	Charge device model (CDM)	500	V
	Machine model (MM)	200	V

THERMAL INFORMATION

THERMAL METRIC ⁽¹⁾		THS4531	THS4531	THS4531	UNITS
		SOIC (P)	VSSOP (MSOP) (DGK)	WQFN (RUN)	
		8 PINS	8 PINS	10 PINS	
θ_{JA}	Junction-to-ambient thermal resistance	133	198	163	°C/W
θ_{JCTop}	Junction-to-case (top) thermal resistance	78	84	66	
θ_{JB}	Junction-to-board thermal resistance	73	120	113	
ψ_{JT}	Junction-to-top characterization parameter	26	19	17	
ψ_{JB}	Junction-to-board characterization parameter	73	118	113	
θ_{JCbott}	Junction-to-case (bottom) thermal resistance	N/A	N/A	N/A	

(1) For more information about traditional and new thermal metrics, see the *IC Package Thermal Metrics* application report, SPRA953.

ELECTRICAL CHARACTERISTICS: $V_S = 2.7\text{ V}$

Test conditions at $T_A = 25^\circ\text{C}$, $V_{S+} = 2.7\text{ V}$, $V_{S-} = 0\text{ V}$, $V_{OCM} = \text{open}$, $V_{OUT} = 2\text{ V}_{PP}$, $R_F = 2\text{ k}\Omega$, $R_L = 2\text{ k}\Omega$ differential, $G = 1\text{ V/V}$, single-ended input, differential output, and input and output referenced to mid-supply, unless otherwise noted.

PARAMETER	CONDITIONS	MIN	TYP	MAX	UNITS	TEST LEVEL ⁽¹⁾
AC PERFORMANCE						
Small-signal bandwidth	$V_{OUT} = 100\text{ mV}_{PP}$, $G = 1$		34		MHz	C
	$V_{OUT} = 100\text{ mV}_{PP}$, $G = 2$		16			
	$V_{OUT} = 100\text{ mV}_{PP}$, $G = 5$		6			
	$V_{OUT} = 100\text{ mV}_{PP}$, $G = 10$		2.7			
Gain-bandwidth product	$V_{OUT} = 100\text{ mV}_{PP}$, $G = 10$		27		MHz	
Large-signal bandwidth	$V_{OUT} = 2\text{ V}_{PP}$, $G = 1$		34		MHz	
Bandwidth for 0.1-dB flatness	$V_{OUT} = 2\text{ V}_{PP}$, $G = 1$		12		MHz	
Slew rate, rise/fall, 25% to 75%	$V_{OUT} = 2\text{-V step}$		190/320		V/ μs	
Rise/fall time, 10% to 90%			5.2/6.1		ns	
Settling time to 1%, rise/fall			25/20		ns	
Settling time to 0.1%, rise/fall			60/60		ns	
Settling time to 0.01%, rise/fall			150/110		ns	
Overshoot/undershoot, rise/fall				1/1		%
2nd-order harmonic distortion	$f = 1\text{ kHz}$, $V_{OUT} = 1\text{ V}_{RMS}$		-122		dBc	
	$f = 10\text{ kHz}$		-127			
	$f = 1\text{ MHz}$		-59			
3rd-order harmonic distortion	$f = 1\text{ kHz}$, $V_{OUT} = 1\text{ V}_{RMS}$		-130		dBc	
	$f = 10\text{ kHz}$		-135			
	$f = 1\text{ MHz}$		-70			
2nd-order intermodulation distortion	$f = 1\text{ MHz}$, 200-Hz tone spacing, V_{OUT} envelope = 1 V_{PP}		-83		dBc	
3rd-order intermodulation distortion			-81			
Input voltage noise	$f = 1\text{ kHz}$		10		nV/ $\sqrt{\text{Hz}}$	
Voltage noise 1/f corner frequency			45		Hz	
Input current noise	$f = 100\text{ kHz}$		0.25		pA/ $\sqrt{\text{Hz}}$	
Current noise 1/f corner frequency			6.5		kHz	
Overdrive recovery time	Overdrive = 0.5 V		65		ns	
Output balance error	$V_{OUT} = 100\text{ mV}$, $f = 1\text{ MHz}$		-65		dB	
Closed-loop output impedance	$f = 1\text{ MHz}$ (differential)		2.5		Ω	

(1) Test levels (all values set by characterization and simulation): (A) 100% tested at $+25^\circ\text{C}$; over temperature limits by characterization and simulation. (B) Not tested in production; limits set by characterization and simulation. (C) Typical value only for information.

ELECTRICAL CHARACTERISTICS: $V_S = 2.7\text{ V}$ (continued)

Test conditions at $T_A = 25^\circ\text{C}$, $V_{S+} = 2.7\text{ V}$, $V_{S-} = 0\text{ V}$, $V_{OCM} = \text{open}$, $V_{OUT} = 2 V_{PP}$, $R_F = 2\text{ k}\Omega$, $R_L = 2\text{ k}\Omega$ differential, $G = 1\text{ V/V}$, single-ended input, differential output, and input and output referenced to mid-supply, unless otherwise noted.

PARAMETER	CONDITIONS	MIN	TYP	MAX	UNITS	TEST LEVEL ⁽¹⁾
DC PERFORMANCE						
Open-loop voltage gain (A_{OL})		100	113		dB	A
Input-referred offset voltage	$T_A = +25^\circ\text{C}$		± 200	± 1000	μV	A
	$T_A = 0^\circ\text{C}$ to $+70^\circ\text{C}$			± 1405		B
	$T_A = -40^\circ\text{C}$ to $+85^\circ\text{C}$			± 1585		
	$T_A = -40^\circ\text{C}$ to $+125^\circ\text{C}$			± 2000		
Input offset voltage drift ⁽²⁾	$T_A = 0^\circ\text{C}$ to $+70^\circ\text{C}$		± 1.7	± 9	$\mu\text{V}/^\circ\text{C}$	B
	$T_A = -40^\circ\text{C}$ to $+85^\circ\text{C}$		± 1.8	± 9		
	$T_A = -40^\circ\text{C}$ to $+125^\circ\text{C}$		± 2	± 10		
Input bias current	$T_A = +25^\circ\text{C}$		160	210	nA	A
	$T_A = 0^\circ\text{C}$ to $+70^\circ\text{C}$			221		B
	$T_A = -40^\circ\text{C}$ to $+85^\circ\text{C}$			222		
	$T_A = -40^\circ\text{C}$ to $+125^\circ\text{C}$			233		
Input bias current drift ⁽²⁾	$T_A = 0^\circ\text{C}$ to $+70^\circ\text{C}$			0.25	nA/ $^\circ\text{C}$	B
	$T_A = -40^\circ\text{C}$ to $+85^\circ\text{C}$			0.25		
	$T_A = -40^\circ\text{C}$ to $+125^\circ\text{C}$			0.25		
Input offset current	$T_A = +25^\circ\text{C}$		± 5	± 50	nA	A
	$T_A = 0^\circ\text{C}$ to $+70^\circ\text{C}$			± 59		B
	$T_A = -40^\circ\text{C}$ to $+85^\circ\text{C}$			± 60		
	$T_A = -40^\circ\text{C}$ to $+125^\circ\text{C}$			± 75		
Input offset current drift ⁽²⁾	$T_A = 0^\circ\text{C}$ to $+70^\circ\text{C}$		± 0.05	± 0.2	nA/ $^\circ\text{C}$	B
	$T_A = -40^\circ\text{C}$ to $+85^\circ\text{C}$		± 0.05	± 0.2		
	$T_A = -40^\circ\text{C}$ to $+125^\circ\text{C}$		± 0.05	± 0.2		
INPUT						
Common-mode input low	$T_A = +25^\circ\text{C}$, CMRR > 87 dB		$V_{S-} - 0.2$	V_{S-}	V	A
	$T_A = -40^\circ\text{C}$ to $+125^\circ\text{C}$, CMRR > 87 dB		$V_{S-} - 0.2$	V_{S-}		B
Common-mode input high	$T_A = +25^\circ\text{C}$, CMRR > 87 dB	$V_{S+} - 1.2$	$V_{S+} - 1.1$		V	A
	$T_A = -40^\circ\text{C}$ to $+125^\circ\text{C}$, CMRR > 87 dB	$V_{S+} - 1.2$	$V_{S+} - 1.1$			B
Common-mode rejection ratio		90	116		dB	A
Input impedance common-mode			$200 \parallel 1.2$		k Ω pF	C
Input impedance differential mode			$200 \parallel 1$			C
OUTPUT						
Single-ended output voltage: low	$T_A = +25^\circ\text{C}$		$V_{S-} + 0.06$	$V_{S-} + 0.2$	V	A
	$T_A = -40^\circ\text{C}$ to $+125^\circ\text{C}$		$V_{S-} + 0.06$	$V_{S-} + 0.2$		B
Single-ended output voltage: high	$T_A = +25^\circ\text{C}$	$V_{S+} - 0.2$	$V_{S+} - 0.11$		V	A
	$T_A = -40^\circ\text{C}$ to $+125^\circ\text{C}$	$V_{S+} - 0.2$	$V_{S+} - 0.11$			B
Output saturation voltage: high/low			110/60		mV	C
Linear output current drive	$T_A = +25^\circ\text{C}$	± 15	± 22		mA	A
	$T_A = -40^\circ\text{C}$ to $+125^\circ\text{C}$	± 15				B

(2) Input offset voltage drift, input bias current drift, and input offset current drift are average values calculated by taking data at the end points, computing the difference, and dividing by the temperature range.

ELECTRICAL CHARACTERISTICS: $V_S = 2.7\text{ V}$ (continued)

Test conditions at $T_A = 25^\circ\text{C}$, $V_{S+} = 2.7\text{ V}$, $V_{S-} = 0\text{ V}$, $V_{OCM} = \text{open}$, $V_{OUT} = 2 V_{PP}$, $R_F = 2\text{ k}\Omega$, $R_L = 2\text{ k}\Omega$ differential, $G = 1\text{ V/V}$, single-ended input, differential output, and input and output referenced to mid-supply, unless otherwise noted.

PARAMETER	CONDITIONS	MIN	TYP	MAX	UNITS	TEST LEVEL ⁽¹⁾
POWER SUPPLY						
Specified operating voltage		2.5		5.5	V	B
Quiescent operating current/ch	$T_A = +25^\circ\text{C}$, $\overline{PD} = V_{S+}$		230	330	μA	A
	$T_A = -40^\circ\text{C}$ to $+125^\circ\text{C}$, $\overline{PD} = V_{S+}$		270	370		B
Power-supply rejection ($\pm\text{PSRR}$)		87	108		dB	A
POWER DOWN						
Enable voltage threshold	Specified on above 2.1 V			2.1	V	A
Disable voltage threshold	Specified off below 0.7 V	0.7				A
Disable pin bias current	$\overline{PD} = V_{S-} + 0.5\text{ V}$		50	500	nA	A
Power-down quiescent current	$\overline{PD} = V_{S-} + 0.5\text{ V}$		0.5	2	μA	A
Turn-on time delay	Time from $\overline{PD} = \text{high}$ to $V_{OUT} = 90\%$ of final value, $R_L = 200\ \Omega$		650		ns	C
Turn-off time delay	Time from $\overline{PD} = \text{low}$ to $V_{OUT} = 10\%$ of original value, $R_L = 200\ \Omega$		20			
OUTPUT COMMON-MODE VOLTAGE CONTROL (V_{OCM})						
Small-signal bandwidth	V_{OCM} input = 100 mV _{PP}		23		MHz	C
Slew rate	V_{OCM} input = 1 V _{STEP}		14		V/ μs	C
Gain		0.99	0.996	1.01	V/V	A
Common-mode offset voltage	Offset = output common-mode voltage – V_{OCM} input voltage		± 1	± 5	mV	A
V_{OCM} input bias current	$V_{OCM} = (V_{S+} - V_{S-})/2$		± 20	± 100	nA	A
V_{OCM} input voltage range		0.8	0.75 to 1.9	1.75	V	A
V_{OCM} input impedance			100 1.6		k Ω pF	C
Default voltage offset from $(V_{S+} - V_{S-})/2$	Offset = output common-mode voltage – $(V_{S+} - V_{S-})/2$		± 3	± 10	mV	A

ELECTRICAL CHARACTERISTICS: $V_S = 5\text{ V}$

Test conditions at $T_A = +25^\circ\text{C}$, $V_{S+} = 5\text{ V}$, $V_{S-} = 0\text{ V}$, $V_{OCM} = \text{open}$, $V_{OUT} = 2\text{ V}_{PP}$, $R_F = 2\text{ k}\Omega$, $R_L = 2\text{ k}\Omega$ differential, $G = 1\text{ V/V}$, single-ended input, differential output, and input and output referenced to mid-supply, unless otherwise noted.

PARAMETER	CONDITIONS	MIN	TYP	MAX	UNITS	TEST LEVEL ⁽¹⁾
AC PERFORMANCE						
Small-signal bandwidth	$V_{OUT} = 100\text{ mV}_{PP}$, $G = 1$		36		MHz	C
	$V_{OUT} = 100\text{ mV}_{PP}$, $G = 2$		17			
	$V_{OUT} = 100\text{ mV}_{PP}$, $G = 5$		6			
	$V_{OUT} = 100\text{ mV}_{PP}$, $G = 10$		2.7			
Gain-bandwidth product	$V_{OUT} = 100\text{ mV}_{PP}$, $G = 10$		27		MHz	
Large-signal bandwidth	$V_{OUT} = 2\text{ V}_{PP}$, $G = 1$		36		MHz	
Bandwidth for 0.1-dB flatness	$V_{OUT} = 2\text{ V}_{PP}$, $G = 1$		15		MHz	
Slew rate, rise/fall, 25% to 75%	$V_{OUT} = 2\text{ V}_{Step}$		220/390		V/ μs	
Rise/fall time, 10% to 90%			4.6/5.6		ns	
Settling time to 1%, rise/fall			25/20		ns	
Settling time to 0.1%, rise/fall			60/60		ns	
Settling time to 0.01%, rise/fall			150/110		ns	
Overshoot/undershoot, rise/fall				1/1		
2nd-order harmonic distortion	$f = 1\text{ kHz}$, $V_{OUT} = 1\text{ V}_{RMS}$		-122		dBc	
	$f = 10\text{ kHz}$		-128			
	$f = 1\text{ MHz}$		-60			
3rd-order harmonic distortion	$f = 1\text{ kHz}$, $V_{OUT} = 1\text{ V}_{RMS}$		-130		dBc	
	$f = 10\text{ kHz}$		-137			
	$f = 1\text{ MHz}$		-71			
2nd-order intermodulation distortion	$f = 1\text{ MHz}$, 200-kHz tone spacing,		-85		dBc	
3rd-order intermodulation distortion	$V_{OUT}\text{ envelope} = 2\text{ V}_{PP}$		-83			
Input voltage noise	$f = 1\text{ kHz}$		10		nV/ $\sqrt{\text{Hz}}$	
Voltage noise 1/f corner frequency			45		Hz	
Input current noise	$f = 100\text{ kHz}$		0.25		pA/ $\sqrt{\text{Hz}}$	
Current noise 1/f corner frequency			6.5		kHz	
Overdrive recovery time	Overdrive = 0.5 V		65		ns	
Output balance error	$V_{OUT} = 100\text{ mV}$, $f = 1\text{ MHz}$		-67		dB	
Closed-loop output impedance	$f = 1\text{ MHz}$ (differential)		2.5		Ω	

(1) Test levels (all values set by characterization and simulation): (A) 100% tested at $+25^\circ\text{C}$; over temperature limits by characterization and simulation. (B) Not tested in production; limits set by characterization and simulation. (C) Typical value only for information.

ELECTRICAL CHARACTERISTICS: $V_S = 5\text{ V}$ (continued)

Test conditions at $T_A = +25^\circ\text{C}$, $V_{S+} = 5\text{ V}$, $V_{S-} = 0\text{ V}$, $V_{OCM} = \text{open}$, $V_{OUT} = 2 V_{PP}$, $R_F = 2\text{ k}\Omega$, $R_L = 2\text{ k}\Omega$ differential, $G = 1\text{ V/V}$, single-ended input, differential output, and input and output referenced to mid-supply, unless otherwise noted.

PARAMETER	CONDITIONS	MIN	TYP	MAX	UNITS	TEST LEVEL ⁽¹⁾
DC PERFORMANCE						
Open-loop voltage gain (A_{OL})		100	114		dB	A
Input-referred offset voltage	$T_A = +25^\circ\text{C}$		± 200	± 1000	μV	A
	$T_A = 0^\circ\text{C}$ to $+70^\circ\text{C}$			± 1405		B
	$T_A = -40^\circ\text{C}$ to $+85^\circ\text{C}$			± 1650		
	$T_A = -40^\circ\text{C}$ to $+125^\circ\text{C}$			± 2000		
Input offset voltage drift ⁽²⁾	$T_A = 0^\circ\text{C}$ to $+70^\circ\text{C}$		± 1.7	± 9	$\mu\text{V}/^\circ\text{C}$	B
	$T_A = -40^\circ\text{C}$ to $+85^\circ\text{C}$		± 2	± 10		
	$T_A = -40^\circ\text{C}$ to $+125^\circ\text{C}$		± 2	± 10		
Input bias current	$T_A = +25^\circ\text{C}$		160	210	nA	A
	$T_A = 0^\circ\text{C}$ to $+70^\circ\text{C}$			222		B
	$T_A = -40^\circ\text{C}$ to $+85^\circ\text{C}$			223		
	$T_A = -40^\circ\text{C}$ to $+125^\circ\text{C}$			235		
Input bias current drift ⁽²⁾	$T_A = 0^\circ\text{C}$ to $+70^\circ\text{C}$		0.04	0.25	nA/ $^\circ\text{C}$	B
	$T_A = -40^\circ\text{C}$ to $+85^\circ\text{C}$		0.04	0.25		
	$T_A = -40^\circ\text{C}$ to $+125^\circ\text{C}$		0.04	0.25		
Input offset current	$T_A = +25^\circ\text{C}$		± 5	± 50	nA	A
	$T_A = 0^\circ\text{C}$ to $+70^\circ\text{C}$			± 59		B
	$T_A = -40^\circ\text{C}$ to $+85^\circ\text{C}$			± 60		
	$T_A = -40^\circ\text{C}$ to $+125^\circ\text{C}$			± 75		
Input offset current drift ⁽²⁾	$T_A = 0^\circ\text{C}$ to $+70^\circ\text{C}$		± 0.05	± 0.2	nA/ $^\circ\text{C}$	B
	$T_A = -40^\circ\text{C}$ to $+85^\circ\text{C}$		± 0.05	± 0.2		
	$T_A = -40^\circ\text{C}$ to $+125^\circ\text{C}$		± 0.05	± 0.2		
INPUT						
Common-mode input: low	$T_A = +25^\circ\text{C}$, CMRR > 87 dB		$V_{S-} - 0.2$	V_{S-}	V	A
	$T_A = -40^\circ\text{C}$ to $+125^\circ\text{C}$, CMRR > 87 dB		$V_{S-} - 0.2$	V_{S-}		B
Common-mode input: high	$T_A = +25^\circ\text{C}$, CMRR > 87 dB	$V_{S+} - 1.2$	$V_{S+} - 1.1$		V	A
	$T_A = -40^\circ\text{C}$ to $+125^\circ\text{C}$, CMRR > 87 dB	$V_{S+} - 1.2$	$V_{S+} - 1.1$			B
Common-mode rejection ratio		90	116		dB	A
Input impedance common-mode			$200 \parallel 1.2$		k Ω pF	C
Input impedance differential mode			$200 \parallel 1$			C
OUTPUT						
Linear output voltage: low	$T_A = +25^\circ\text{C}$		$V_{S-} + 0.1$	$V_{S-} + 0.2$	V	A
	$T_A = -40^\circ\text{C}$ to $+125^\circ\text{C}$		$V_{S-} + 0.1$	$V_{S-} + 0.2$		B
Linear output voltage: high	$T_A = +25^\circ\text{C}$	$V_{S+} - 0.25$	$V_{S+} - 0.12$		V	A
	$T_A = -40^\circ\text{C}$ to $+125^\circ\text{C}$	$V_{S+} - 0.25$	$V_{S+} - 0.12$			B
Output saturation voltage: high/low			120/100		mV	C
Linear output current drive	$T_A = +25^\circ\text{C}$	± 15	± 25		mA	A
	$T_A = -40^\circ\text{C}$ to $+125^\circ\text{C}$	± 15				B

(2) Input offset voltage drift, input bias current drift, and input offset current drift are average values calculated by taking data at the end points, computing the difference, and dividing by the temperature range.

ELECTRICAL CHARACTERISTICS: $V_S = 5\text{ V}$ (continued)

Test conditions at $T_A = +25^\circ\text{C}$, $V_{S+} = 5\text{ V}$, $V_{S-} = 0\text{ V}$, $V_{OCM} = \text{open}$, $V_{OUT} = 2\text{ V}_{PP}$, $R_F = 2\text{ k}\Omega$, $R_L = 2\text{ k}\Omega$ differential, $G = 1\text{ V/V}$, single-ended input, differential output, and input and output referenced to mid-supply, unless otherwise noted.

PARAMETER	CONDITIONS	MIN	TYP	MAX	UNITS	TEST LEVEL ⁽¹⁾
POWER SUPPLY						
Specified operating voltage		2.5		5.5	V	B
Quiescent operating current/ch	$T_A = 25^\circ\text{C}$, $\overline{PD} = V_{S+}$		250	350	μA	A
	$T_A = -40^\circ\text{C}$ to 125°C , $\overline{PD} = V_{S+}$		290	390		B
Power-supply rejection ($\pm\text{PSRR}$)		87	108		dB	A
POWER DOWN						
Enable voltage threshold	Specified on above 2.1 V			2.1	V	A
Disable voltage threshold	Specified off below 0.7 V	0.7				A
Disable pin bias current	$\overline{PD} = V_{S-} + 0.5\text{ V}$		50	500	nA	A
Power-down quiescent current	$\overline{PD} = V_{S-} + 0.5\text{ V}$		0.5	2	μA	A
Turn-on time delay	Time from $\overline{PD} = \text{high}$ to $V_{OUT} = 90\%$ of final value, $R_L = 200\ \Omega$		600		ns	C
Turn-off time delay	Time from $\overline{PD} = \text{low}$ to $V_{OUT} = 10\%$ of original value, $R_L = 200\ \Omega$		15			
OUTPUT COMMON-MODE VOLTAGE CONTROL (V_{OCM})						
Small-signal bandwidth	V_{OCM} input = 100 mV_{PP}		24		MHz	C
Slew rate	V_{OCM} input = 1 V_{STEP}		15		V/ μs	C
Gain		0.99	0.996	1.01	V/V	A
Common-mode offset voltage	Offset = output common-mode voltage – V_{OCM} input voltage		± 1	± 5	mV	A
V_{OCM} input bias current	$V_{OCM} = (V_{S+} - V_{S-})/2$		± 20	± 120	nA	A
V_{OCM} input voltage range		0.95	0.75 to 4.15	4.0	V	A
V_{OCM} input impedance			65 0.86		k Ω pF	C
Default voltage offset from $(V_{S+} - V_{S-})/2$	Offset = output common-mode voltage – $(V_{S+} - V_{S-})/2$		± 3	± 10	mV	A

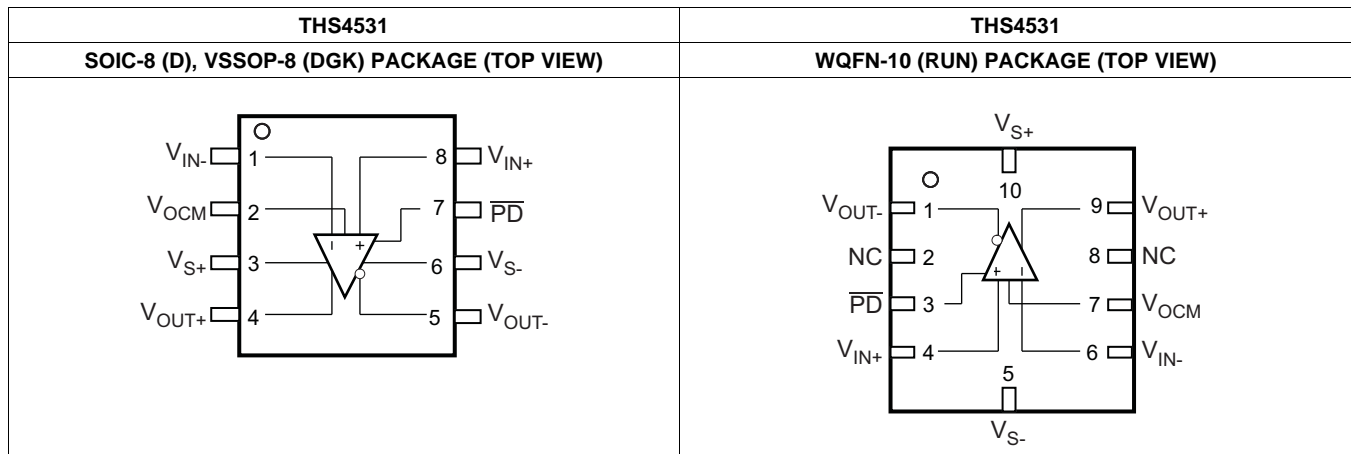
DEVICE INFORMATION
PIN CONFIGURATIONS

PIN FUNCTIONS

NUMBER	NAME	DESCRIPTION
THS4531 D, DGK PACKAGE		
1	V_{IN-}	Inverted (negative) output feedback
2	V_{OCM}	Common-mode voltage input
3	V_{S+}	Amplifier positive power-supply input
4	V_{OUT+}	Noninverted amplifier output
5	V_{OUT-}	Inverted amplifier output
6	V_{S-}	Amplifier negative power-supply input. Note V_{S-} tied together on multichannel devices.
7	\overline{PD}	Power-down, \overline{PD} = logic low = low power mode, \overline{PD} = logic high = normal operation (PIN MUST BE DRIVEN)
8	V_{IN+}	Noninverted amplifier input
THS4531 RUN PACKAGE		
1	V_{OUT-}	Inverted amplifier output
2, 8	NC	No internal connection
3	\overline{PD}	Power-down, \overline{PD} = logic low = low power mode, \overline{PD} = logic high = normal operation (PIN MUST BE DRIVEN)
4	V_{IN+}	Noninverted amplifier input
5	V_{S-}	Amplifier negative power-supply input. Note V_{S-} tied together on multichannel devices.
6	V_{IN-}	Inverting amplifier input
7	V_{OCM}	Common-mode voltage input
9	V_{OUT+}	Noninverted amplifier output
10	V_{S+}	Amplifier positive power-supply input

TABLE OF GRAPHS

Description	$V_S = 2.7\text{ V}$	$V_S = 5\text{ V}$
Small-signal frequency response	Figure 2	Figure 35
Large-signal frequency response	Figure 3	Figure 36
Large- and small- signal pulse response	Figure 4	Figure 37
Single-ended slew rate vs V_{OUT} step	Figure 5	Figure 38
Differential slew rate vs V_{OUT} step	Figure 6	Figure 39
Overdrive recovery	Figure 7	Figure 40
10-kHz FFT on audio analyzer	Figure 8	Figure 41
Harmonic distortion vs Frequency	Figure 9	Figure 42
Harmonic distortion vs Output voltage at 1 MHz	Figure 10	Figure 43
Harmonic distortion vs Gain at 1 MHz	Figure 11	Figure 44
Harmonic distortion vs Load at 1 MHz	Figure 12	Figure 45
Harmonic distortion vs V_{OCM} at 1 MHz	Figure 13	Figure 46
Two-tone, 2nd and 3rd order intermodulation distortion vs Frequency	Figure 14	Figure 47
Single-ended output voltage swing vs Load resistance	Figure 15	Figure 48
Single-ended output saturation voltage vs Load current	Figure 16	Figure 49
Main amplifier differential output impedance vs Frequency	Figure 17	Figure 50
Frequency response vs C_{LOAD}	Figure 18	Figure 51
R_O vs C_{LOAD}	Figure 19	Figure 52
Rejection ratio vs Frequency	Figure 20	Figure 53
Turn-on time	Figure 21	Figure 54
Turn-off time	Figure 22	Figure 55
Input-referred voltage noise and current noise spectral density	Figure 23	Figure 56
Main amplifier differential open-loop gain and phase vs Frequency	Figure 24	Figure 57
Output balance error vs Frequency	Figure 25	Figure 58
V_{OCM} small signal frequency response	Figure 26	Figure 59
V_{OCM} large and small signal pulse response	Figure 27	Figure 60
V_{OCM} input impedance vs frequency	Figure 28	Figure 61
Count vs input offset current	Figure 29	Figure 62
Count vs input offset current temperature drift	Figure 30	Figure 63
Input offset current vs temperature	Figure 31	Figure 64
Count vs input offset voltage	Figure 32	Figure 65
Count vs input offset voltage temperature drift	Figure 33	Figure 66
Input offset voltage vs temperature	Figure 34	Figure 67

TYPICAL CHARACTERISTICS: $V_S = 2.7V$

Test conditions unless otherwise noted: $V_{S+} = 2.7V$, $V_{S-} = 0V$, CM = open, $V_{OUT} = 2V_{pp}$, $R_F = 2k\Omega$, $R_L = 2k\Omega$ Differential, $G = 1V/V$, Single-Ended Input, Differential Output, Input and Output Referenced to mid-supply unless otherwise noted.

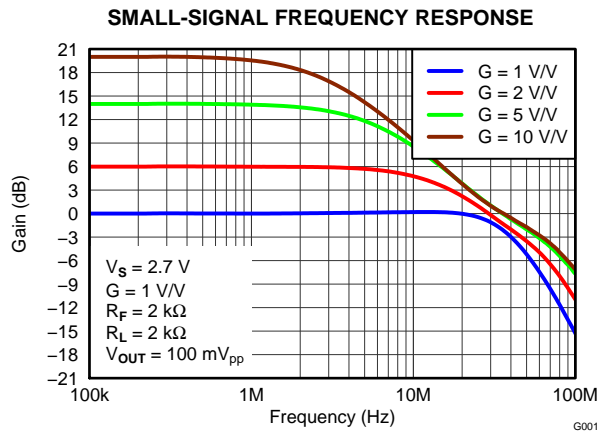

Figure 2.

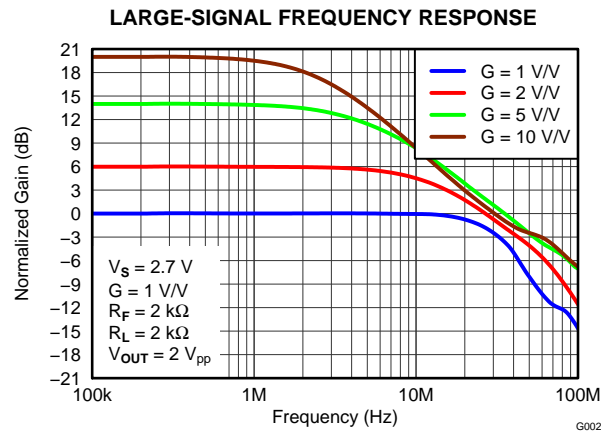

Figure 3.

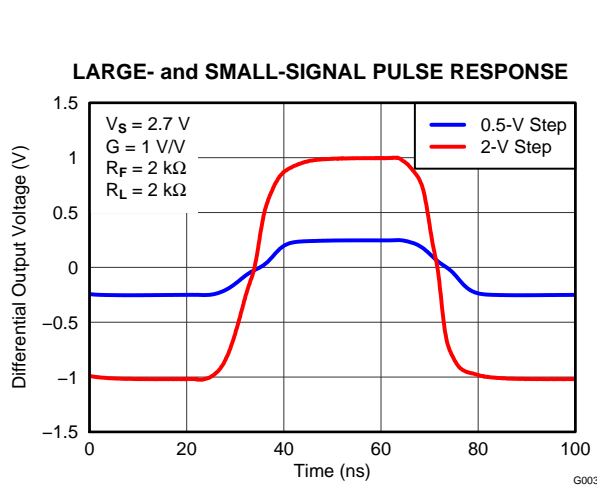

Figure 4.

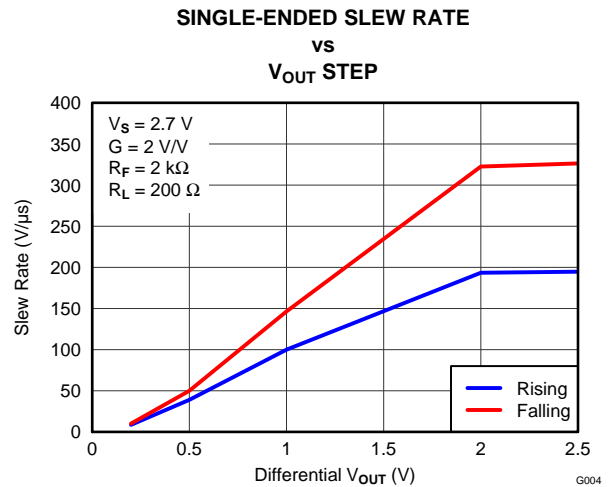

Figure 5.

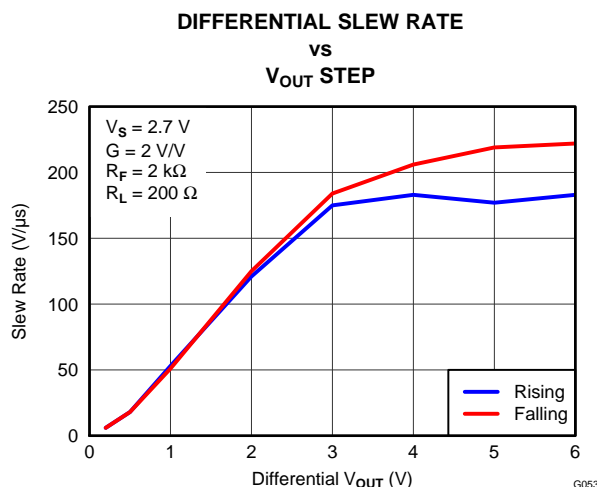

Figure 6.

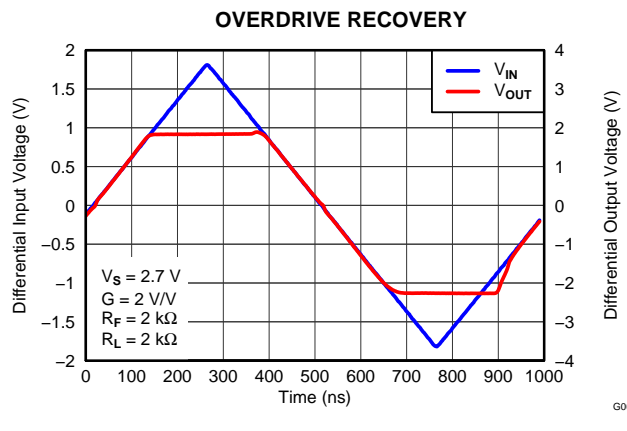

Figure 7.

TYPICAL CHARACTERISTICS: $V_S = 2.7V$ (continued)

Test conditions unless otherwise noted: $V_{S+} = 2.7V$, $V_{S-} = 0V$, CM = open, $V_{OUT} = 2V_{pp}$, $R_F = 2k\Omega$, $R_L = 2k\Omega$ Differential, $G = 1V/V$, Single-Ended Input, Differential Output, Input and Output Referenced to mid-supply unless otherwise noted.

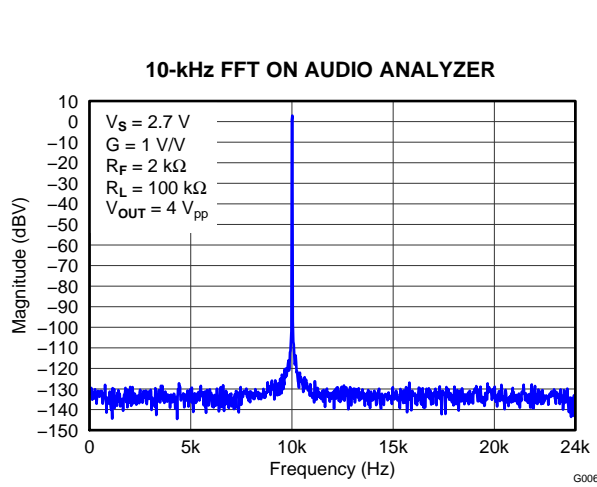

Figure 8.

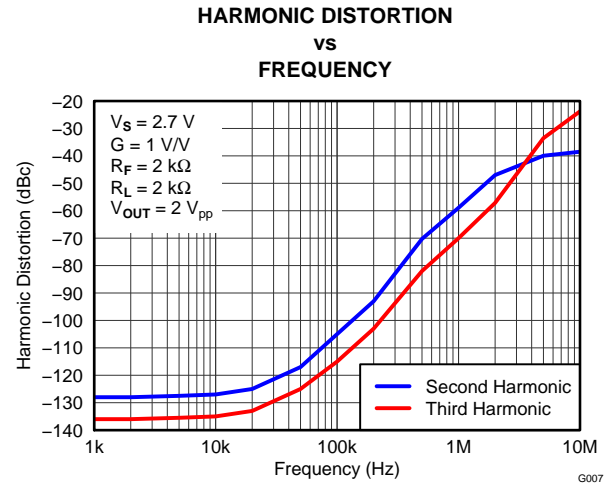

Figure 9.

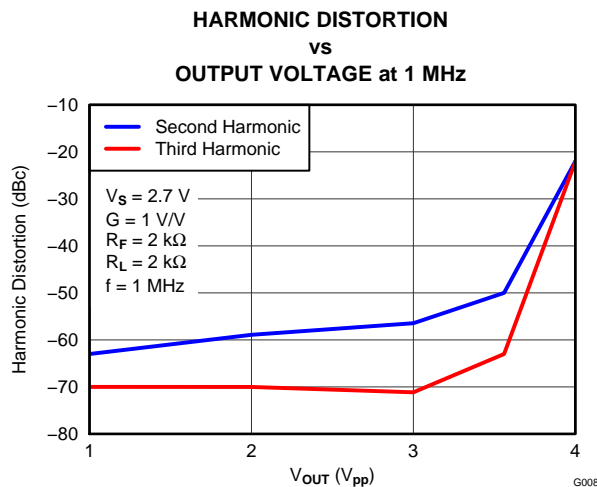

Figure 10.

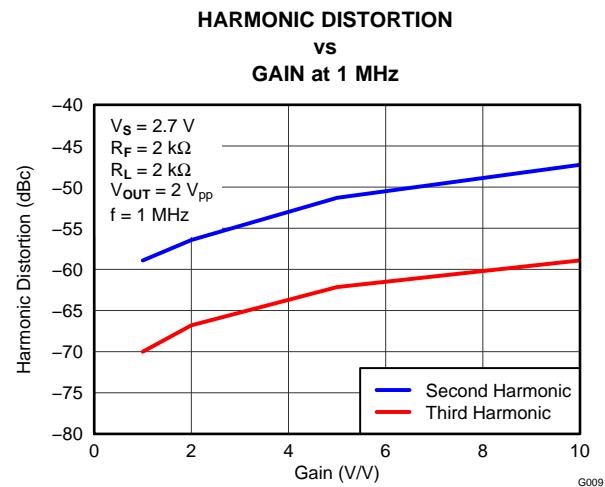

Figure 11.

TYPICAL CHARACTERISTICS: $V_S = 2.7V$ (continued)

Test conditions unless otherwise noted: $V_{S+} = 2.7V$, $V_{S-} = 0V$, CM = open, $V_{OUT} = 2V_{pp}$, $R_F = 2k\Omega$, $R_L = 2k\Omega$ Differential, $G = 1V/V$, Single-Ended Input, Differential Output, Input and Output Referenced to mid-supply unless otherwise noted.

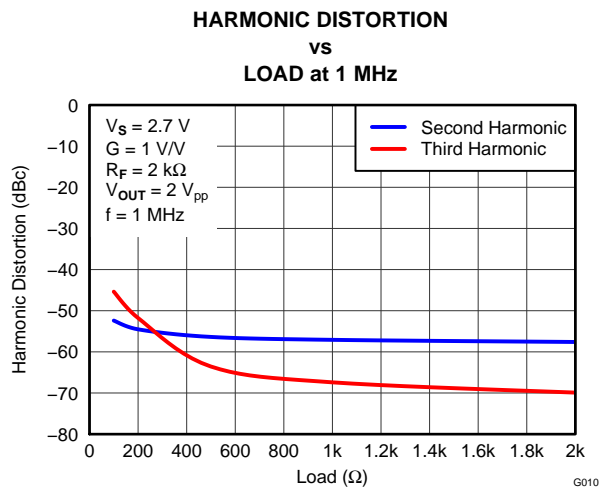

Figure 12.

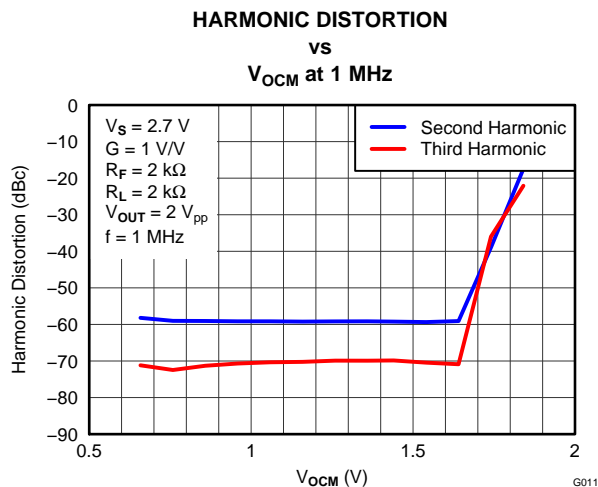

Figure 13.

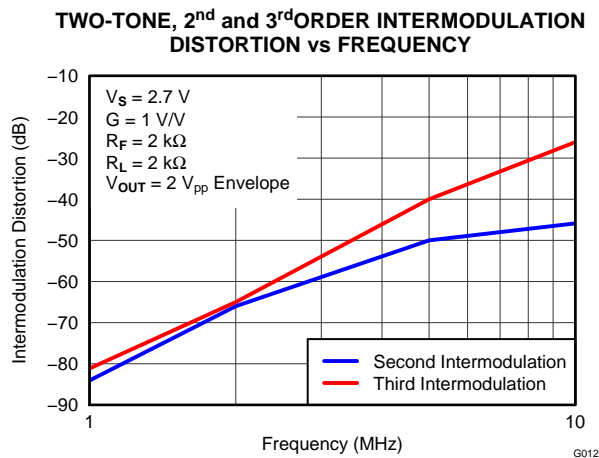

Figure 14.

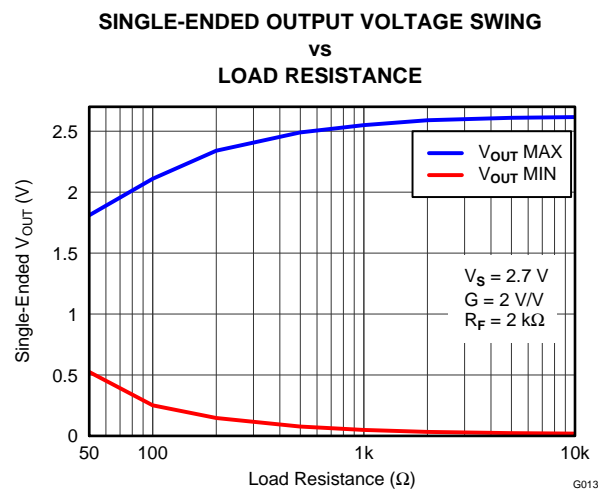

Figure 15.

TYPICAL CHARACTERISTICS: $V_S = 2.7V$ (continued)

Test conditions unless otherwise noted: $V_{S+} = 2.7V$, $V_{S-} = 0V$, CM = open, $V_{OUT} = 2V_{pp}$, $R_F = 2k\Omega$, $R_L = 2k\Omega$ Differential, $G = 1V/V$, Single-Ended Input, Differential Output, Input and Output Referenced to mid-supply unless otherwise noted.

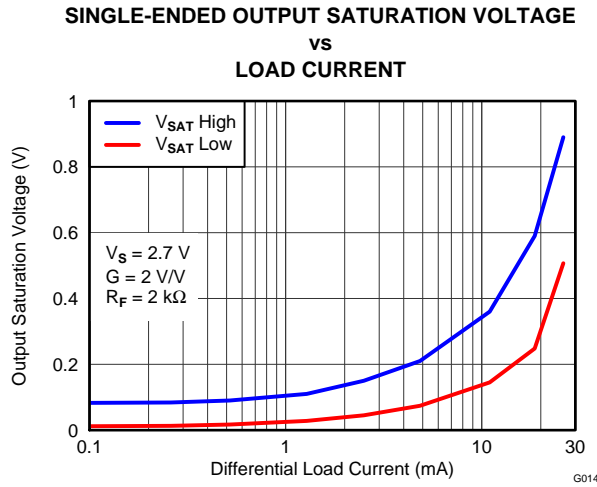

Figure 16.

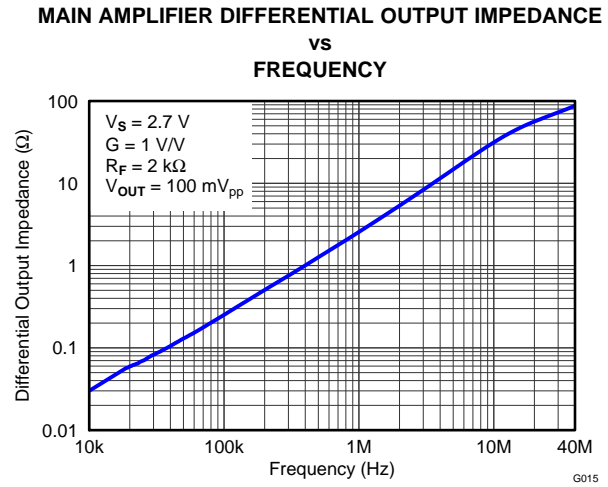

Figure 17.

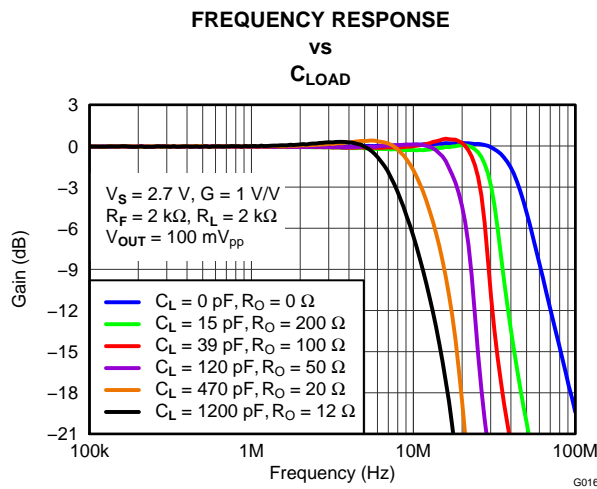

Figure 18.

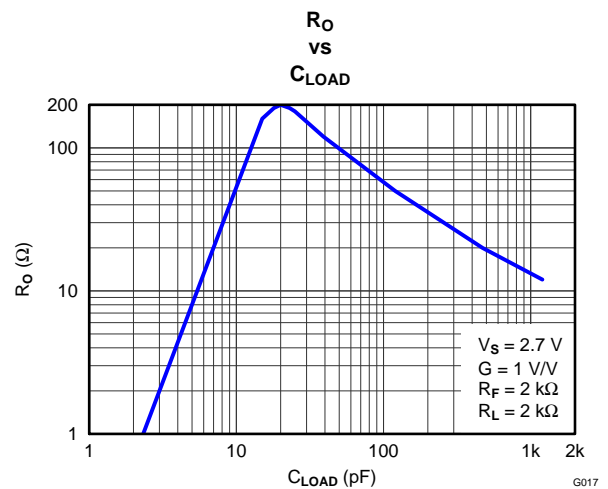

Figure 19.

TYPICAL CHARACTERISTICS: $V_S = 2.7V$ (continued)

Test conditions unless otherwise noted: $V_{S+} = 2.7V$, $V_{S-} = 0V$, CM = open, $V_{OUT} = 2V_{pp}$, $R_F = 2k\Omega$, $R_L = 2k\Omega$ Differential, $G = 1V/V$, Single-Ended Input, Differential Output, Input and Output Referenced to mid-supply unless otherwise noted.

**REJECTION RATIO
vs
FREQUENCY**

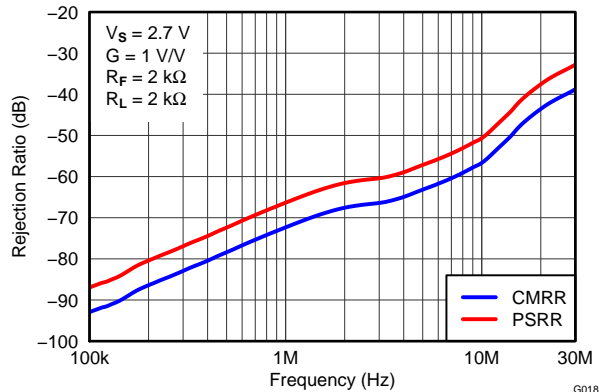

Figure 20.

TURN-ON TIME

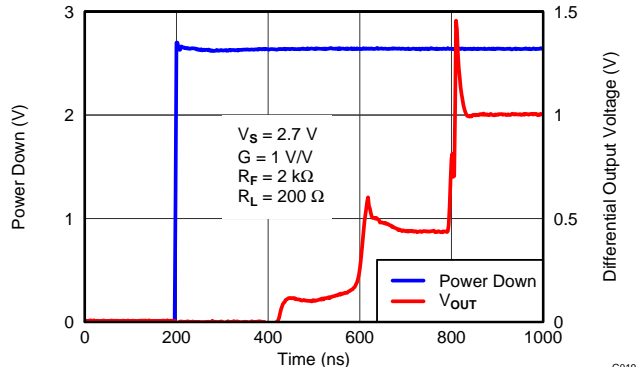

Figure 21.

TURN-OFF TIME

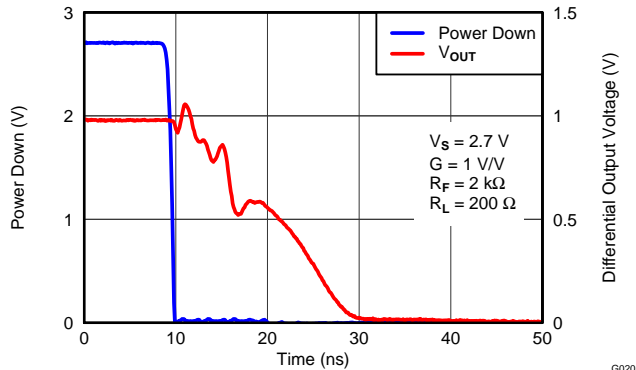

Figure 22.

**INPUT-REFERRED VOLTAGE NOISE
and
CURRENT NOISE SPECTRAL DENSITY**

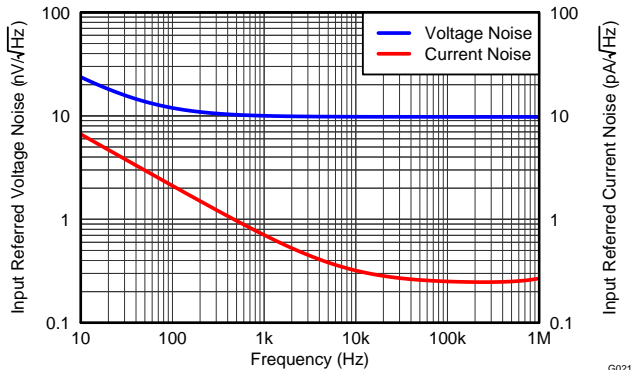

Figure 23.

TYPICAL CHARACTERISTICS: $V_S = 2.7V$ (continued)

Test conditions unless otherwise noted: $V_{S+} = 2.7V$, $V_{S-} = 0V$, CM = open, $V_{OUT} = 2V_{pp}$, $R_F = 2k\Omega$, $R_L = 2k\Omega$ Differential, $G = 1V/V$, Single-Ended Input, Differential Output, Input and Output Referenced to mid-supply unless otherwise noted.

MAIN AMPLIFIER DIFFERENTIAL OPEN-LOOP GAIN and PHASE vs FREQUENCY

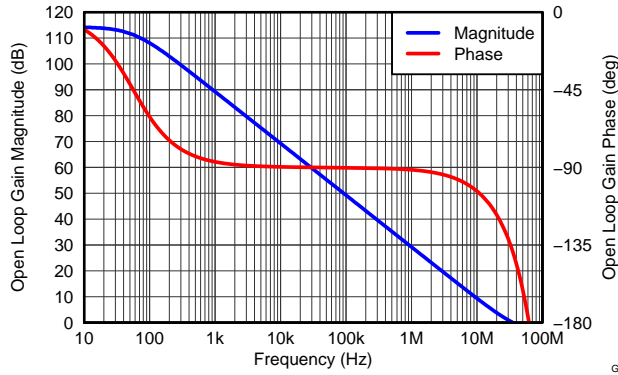

Figure 24.

OUTPUT BALANCE ERROR vs FREQUENCY

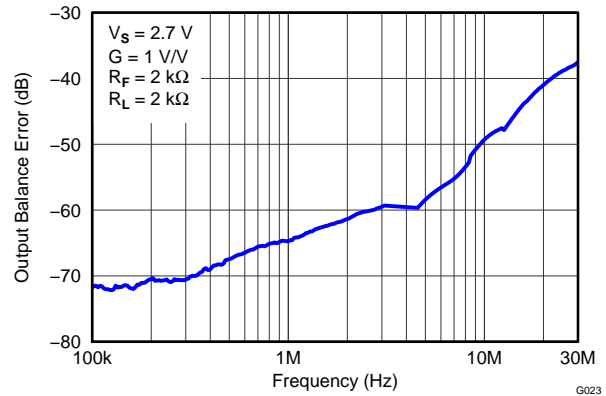

Figure 25.

V_{OCM} SMALL-SIGNAL FREQUENCY RESPONSE

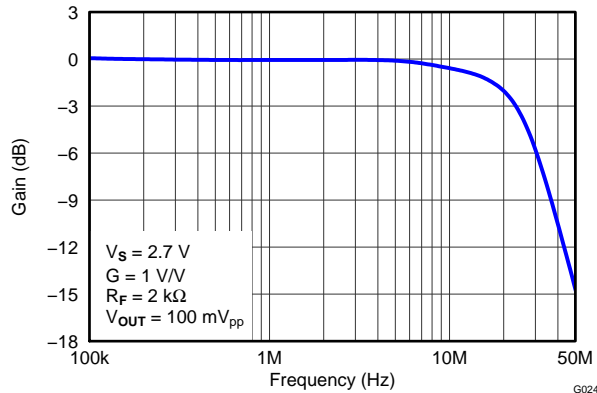

Figure 26.

V_{OCM} LARGE- and SMALL SIGNAL PULSE RESPONSE

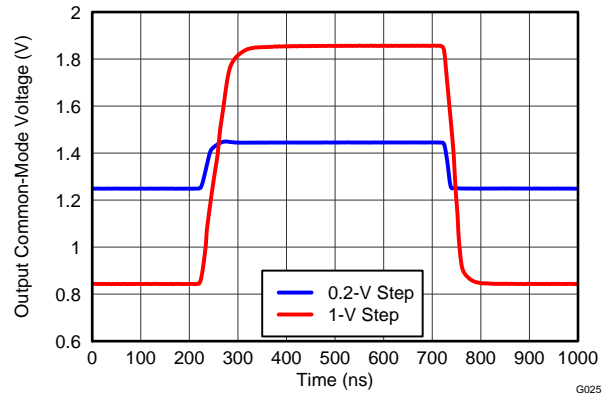

Figure 27.

TYPICAL CHARACTERISTICS: $V_S = 2.7V$ (continued)

Test conditions unless otherwise noted: $V_{S+} = 2.7V$, $V_{S-} = 0V$, CM = open, $V_{OUT} = 2V_{pp}$, $R_F = 2k\Omega$, $R_L = 2k\Omega$ Differential, G = 1V/V, Single-Ended Input, Differential Output, Input and Output Referenced to mid-supply unless otherwise noted.

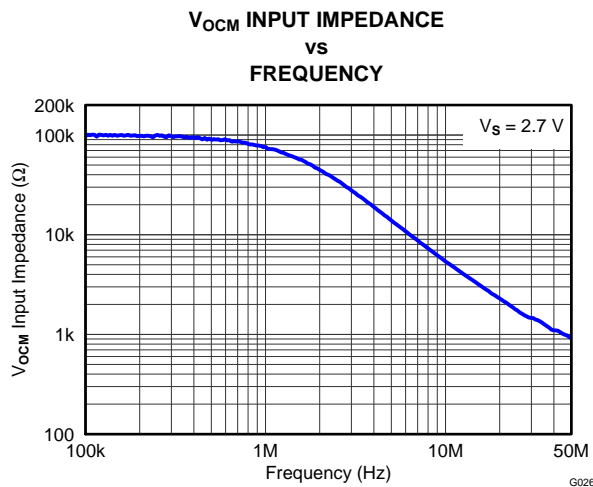

Figure 28.

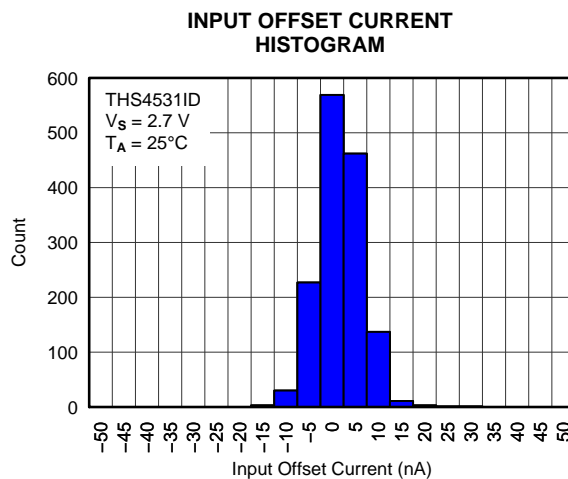

Figure 29.

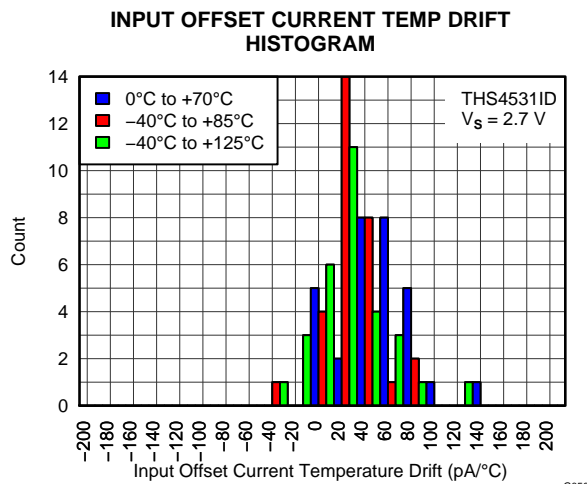

Figure 30.

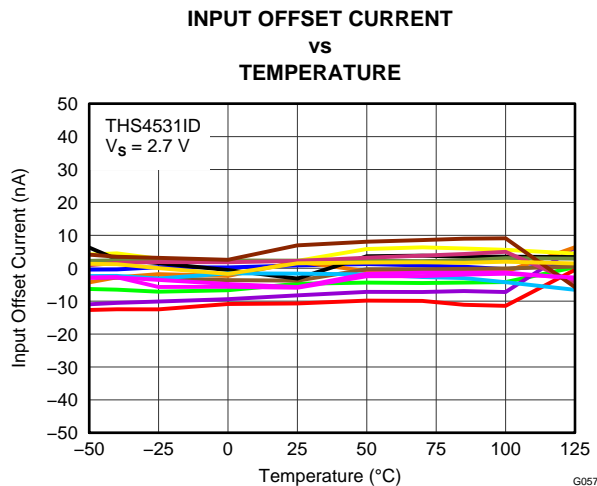

Figure 31.

TYPICAL CHARACTERISTICS: $V_S = 2.7V$ (continued)

Test conditions unless otherwise noted: $V_{S+} = 2.7V$, $V_{S-} = 0V$, CM = open, $V_{OUT} = 2V_{pp}$, $R_F = 2k\Omega$, $R_L = 2k\Omega$ Differential, G = 1V/V, Single-Ended Input, Differential Output, Input and Output Referenced to mid-supply unless otherwise noted.

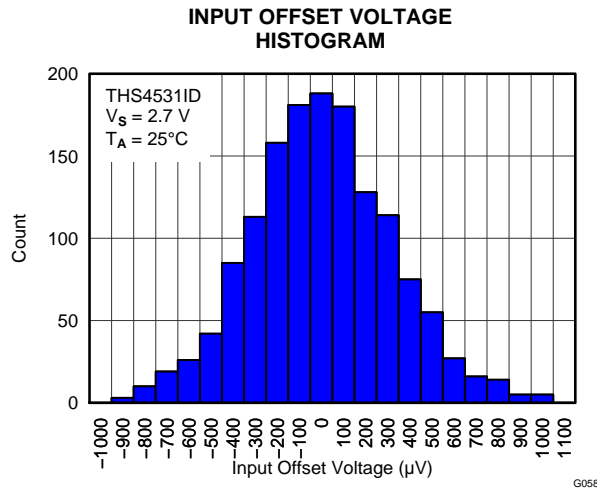

Figure 32.

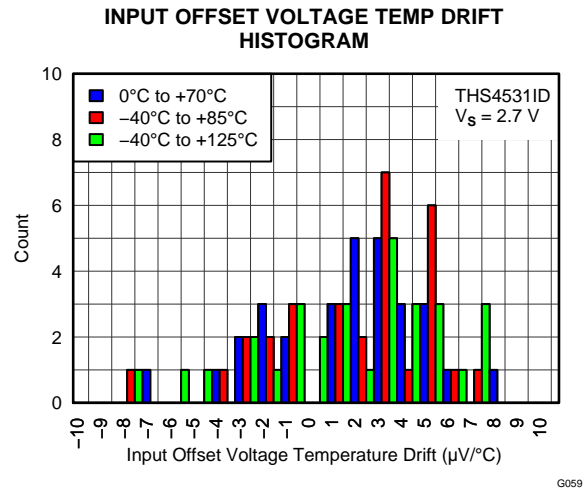

Figure 33.

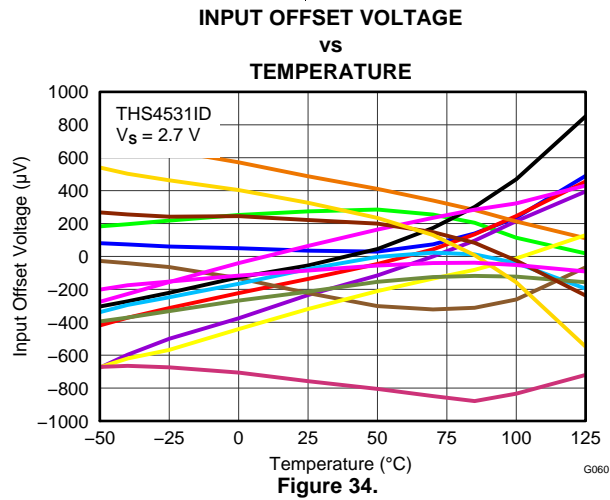

Figure 34.

TYPICAL CHARACTERISTICS: $V_S = 5V$

Test conditions unless otherwise noted: $V_{S+} = 5V$, $V_{S-} = 0V$, $V_{OCM} = \text{open}$, $V_{OUT} = 2V_{pp}$, $R_F = 2k\Omega$, $R_L = 2k\Omega$ Differential, $G = 1V/V$, Single-Ended Input, Differential Output, Input and Output Referenced to mid-supply, $T_A = 25^\circ C$ unless otherwise noted.

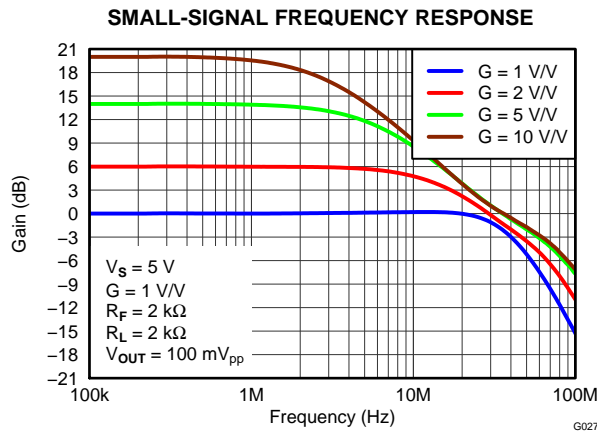

Figure 35.

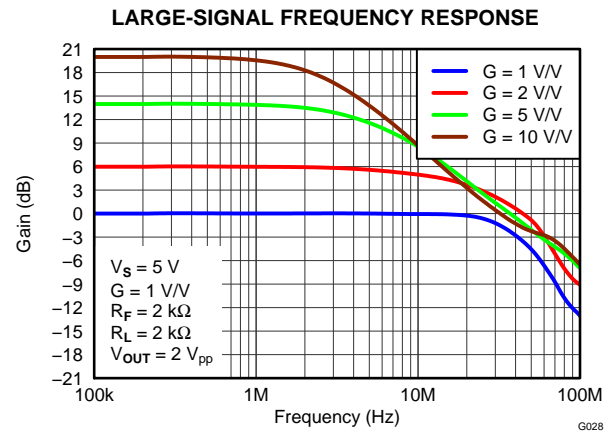

Figure 36.

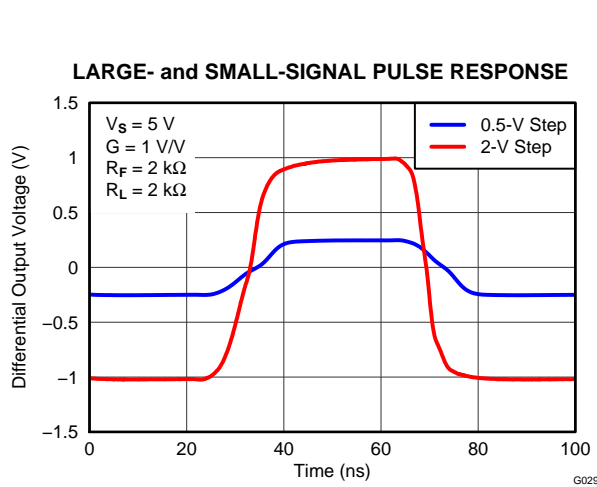

Figure 37.

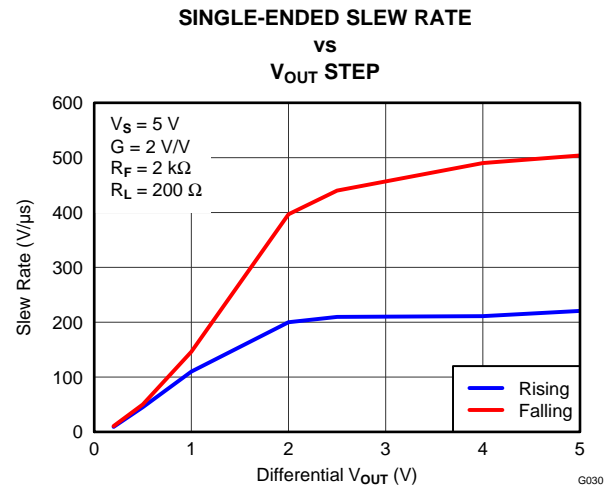

Figure 38.

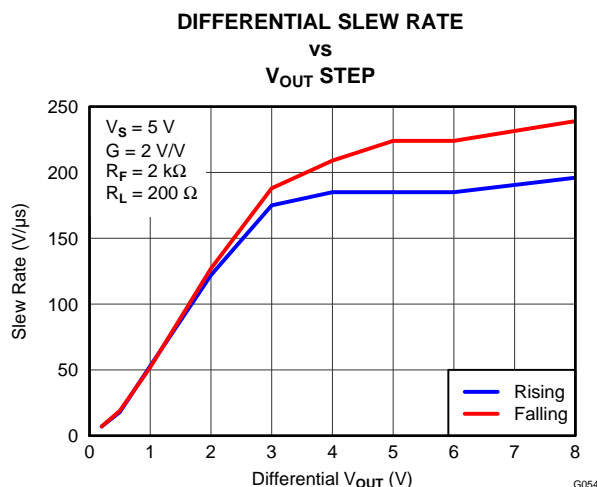

Figure 39.

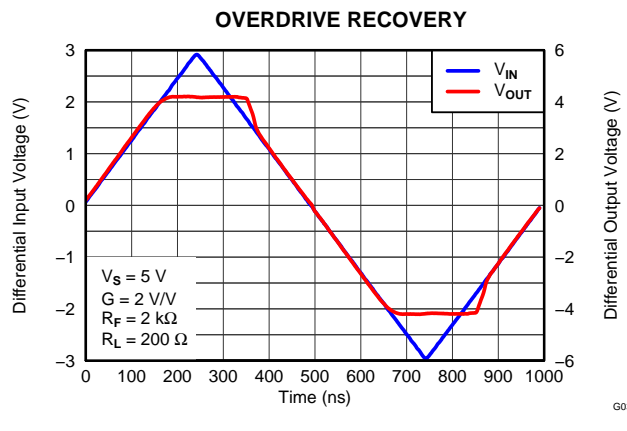

Figure 40.

TYPICAL CHARACTERISTICS: $V_S = 5V$ (continued)

Test conditions unless otherwise noted: $V_{S+} = 5V$, $V_{S-} = 0V$, $V_{OCM} = \text{open}$, $V_{OUT} = 2V_{pp}$, $R_F = 2k\Omega$, $R_L = 2k\Omega$ Differential, $G = 1V/V$, Single-Ended Input, Differential Output, Input and Output Referenced to mid-supply, $T_A = 25^\circ\text{C}$ unless otherwise noted.

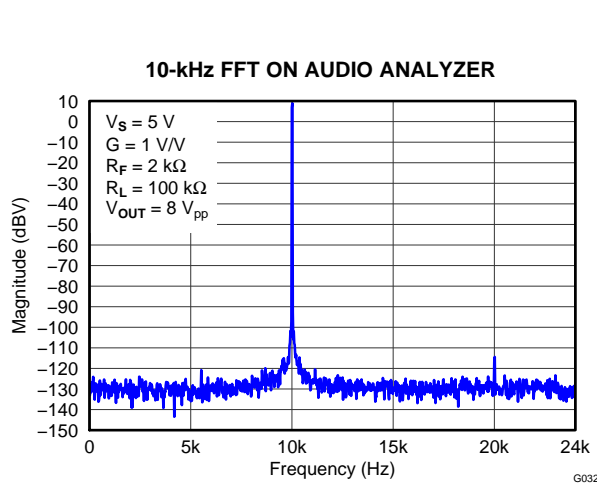

Figure 41.

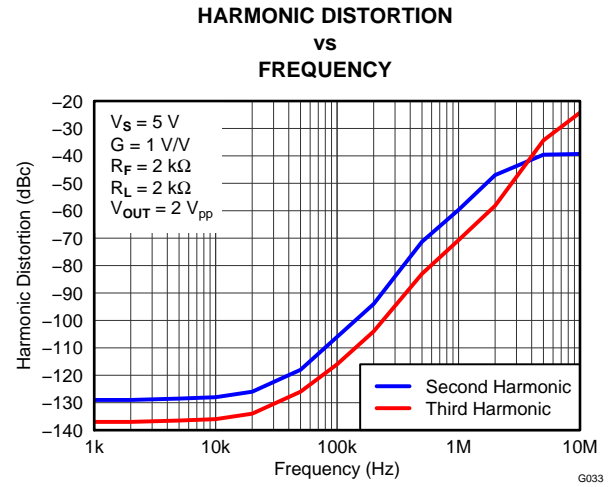

Figure 42.

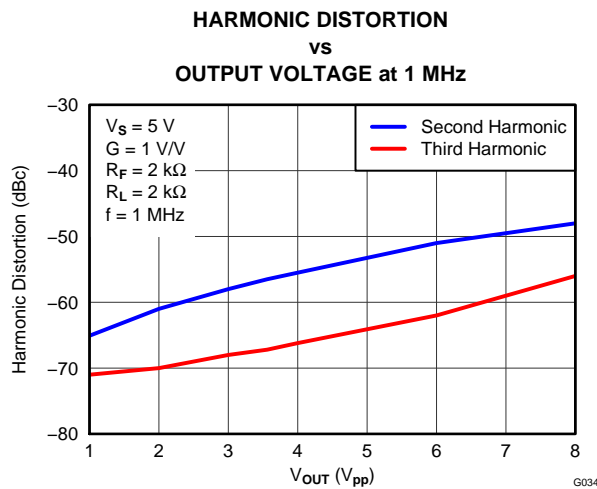

Figure 43.

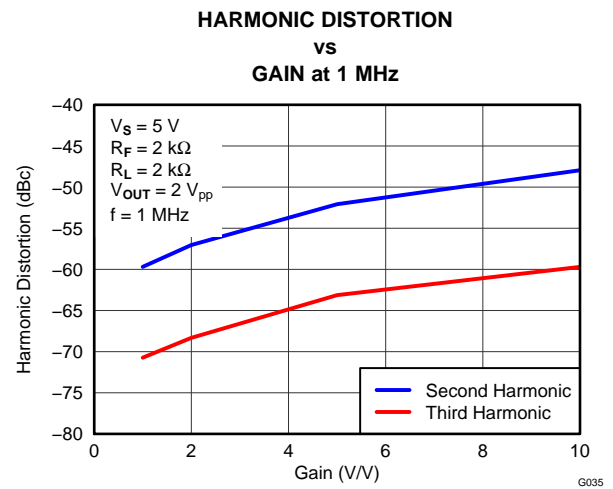

Figure 44.

TYPICAL CHARACTERISTICS: $V_S = 5V$ (continued)

Test conditions unless otherwise noted: $V_{S+} = 5V$, $V_{S-} = 0V$, V_{OCM} = open, $V_{OUT} = 2V_{pp}$, $R_F = 2k\Omega$, $R_L = 2k\Omega$ Differential, $G = 1V/V$, Single-Ended Input, Differential Output, Input and Output Referenced to mid-supply, $T_A = 25^\circ C$ unless otherwise noted.

**HARMONIC DISTORTION
vs
LOAD at 1 MHz**

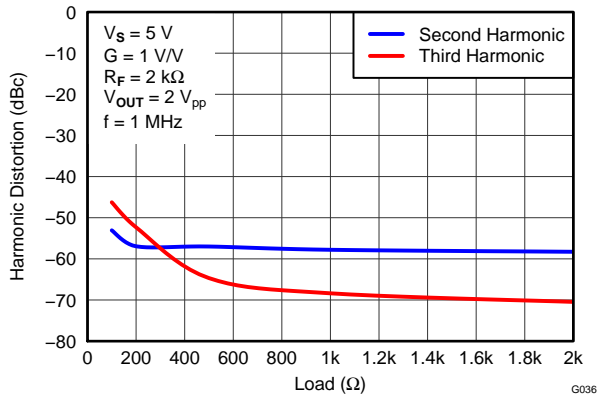

Figure 45.

**HARMONIC DISTORTION
vs
 V_{OCM} at 1 MHz**

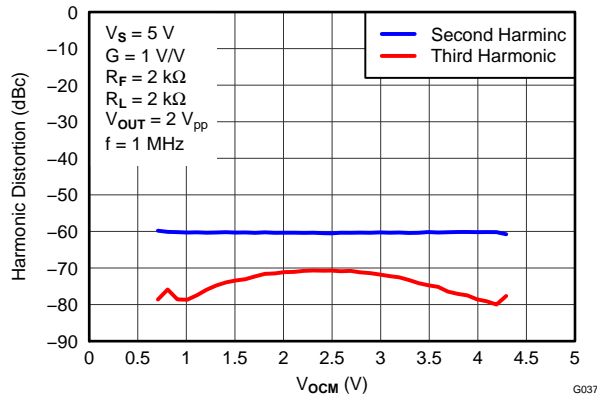

Figure 46.

**TWO-TONE, 2nd and 3rd ORDER INTERMODULATION
DISTORTION vs FREQUENCY**

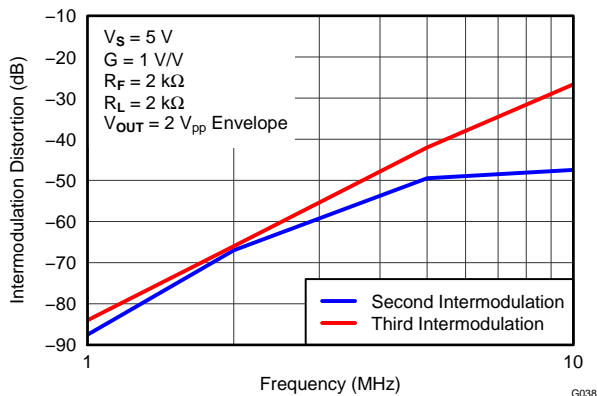

Figure 47.

**SINGLE-ENDED OUTPUT VOLTAGE SWING
vs
LOAD RESISTANCE**

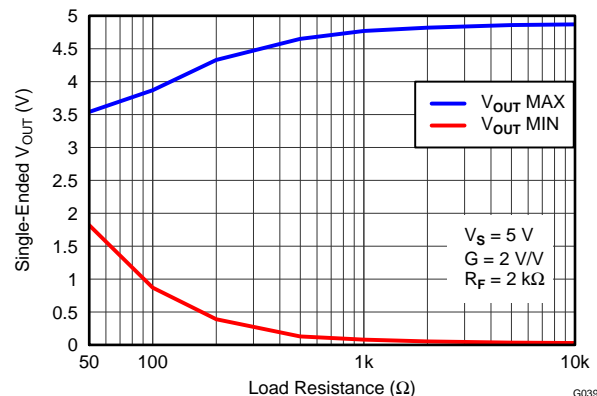

Figure 48.

TYPICAL CHARACTERISTICS: $V_S = 5V$ (continued)

Test conditions unless otherwise noted: $V_{S+} = 5V$, $V_{S-} = 0V$, V_{OCM} = open, $V_{OUT} = 2V_{pp}$, $R_F = 2k\Omega$, $R_L = 2k\Omega$ Differential, $G = 1V/V$, Single-Ended Input, Differential Output, Input and Output Referenced to mid-supply, $T_A = 25^\circ C$ unless otherwise noted.

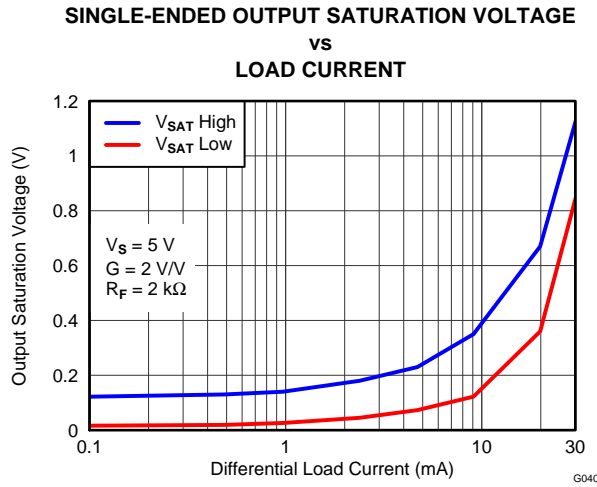

Figure 49.

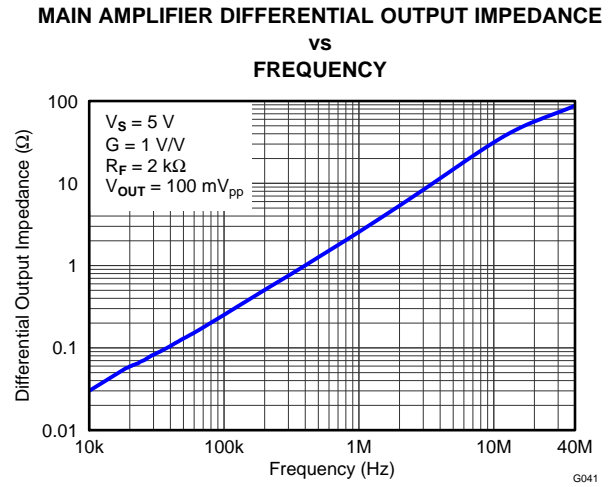

Figure 50.

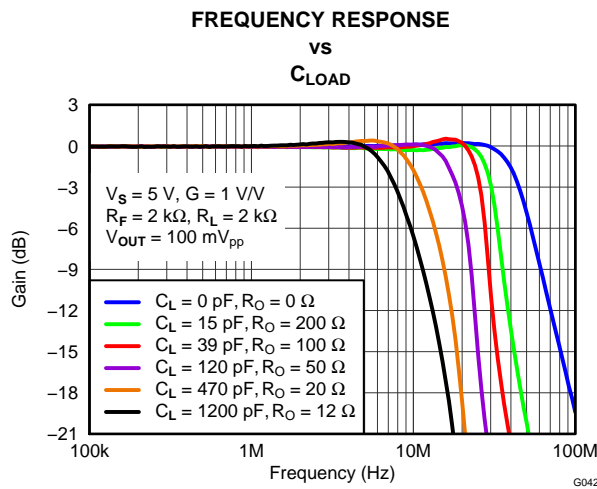

Figure 51.

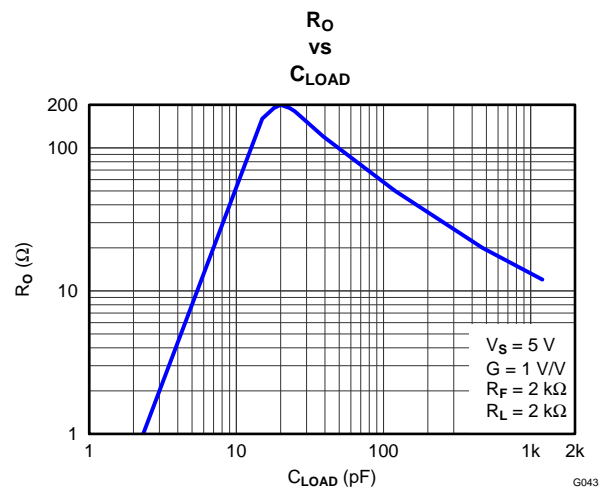

Figure 52.

TYPICAL CHARACTERISTICS: $V_S = 5V$ (continued)

Test conditions unless otherwise noted: $V_{S+} = 5V$, $V_{S-} = 0V$, $V_{OCM} = \text{open}$, $V_{OUT} = 2V_{pp}$, $R_F = 2k\Omega$, $R_L = 2k\Omega$ Differential, $G = 1V/V$, Single-Ended Input, Differential Output, Input and Output Referenced to mid-supply, $T_A = 25^\circ\text{C}$ unless otherwise noted.

**REJECTION RATIO
vs
FREQUENCY**

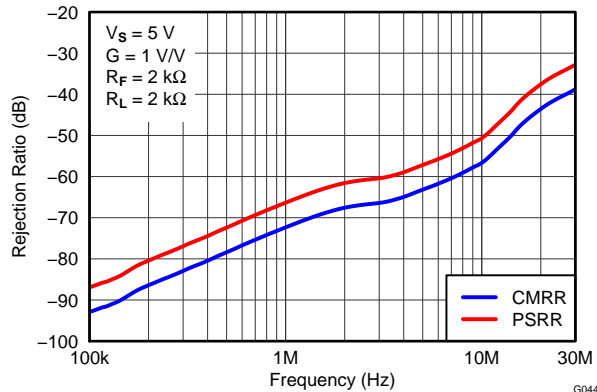

Figure 53.

TURN-ON TIME

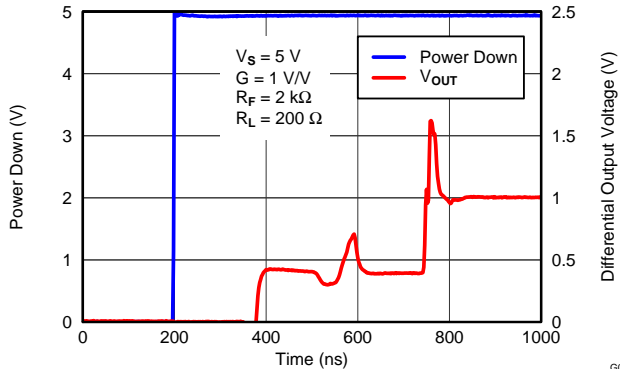

Figure 54.

TURN-OFF TIME

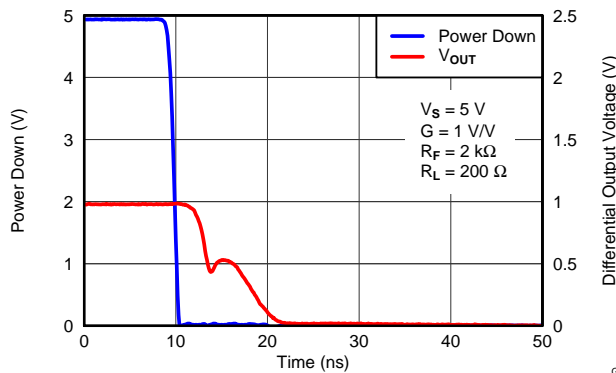

Figure 55.

**INPUT-REFERRED VOLTAGE NOISE
and
CURRENT NOISE SPECTRAL DENSITY**

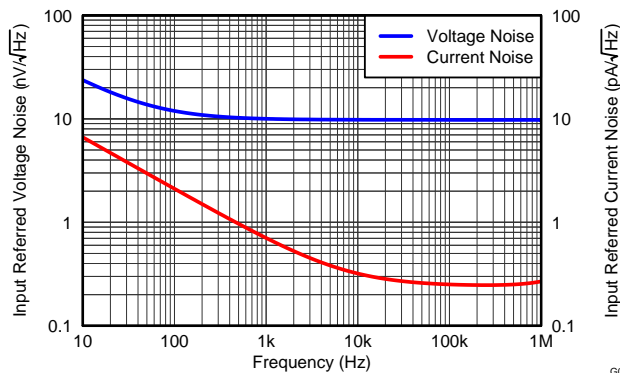

Figure 56.

TYPICAL CHARACTERISTICS: $V_S = 5V$ (continued)

Test conditions unless otherwise noted: $V_{S+} = 5V$, $V_{S-} = 0V$, $V_{OCM} = \text{open}$, $V_{OUT} = 2V_{pp}$, $R_F = 2k\Omega$, $R_L = 2k\Omega$ Differential, $G = 1V/V$, Single-Ended Input, Differential Output, Input and Output Referenced to mid-supply, $T_A = 25^\circ C$ unless otherwise noted.

MAIN AMPLIFIER DIFFERENTIAL OPEN-LOOP GAIN and PHASE vs FREQUENCY

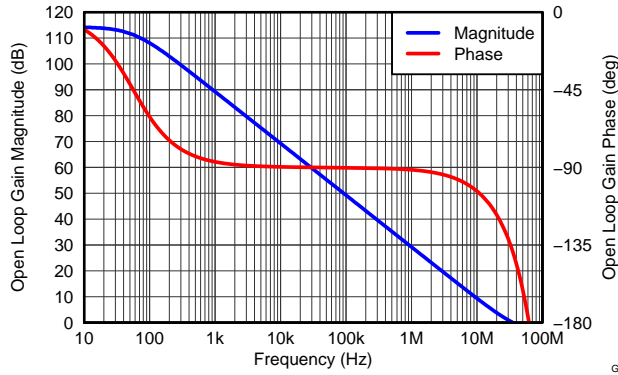

Figure 57.

OUTPUT BALANCE ERROR vs FREQUENCY

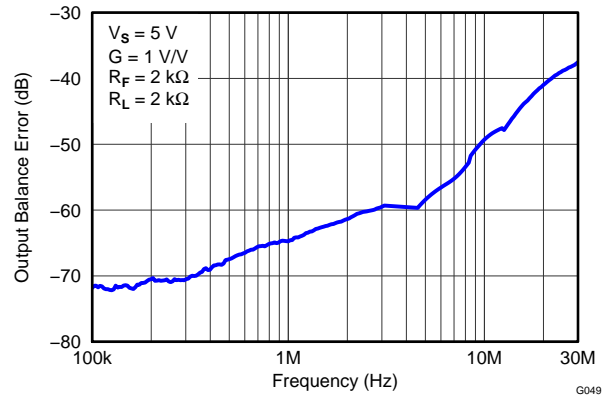

Figure 58.

V_{OCM} SMALL-SIGNAL FREQUENCY RESPONSE

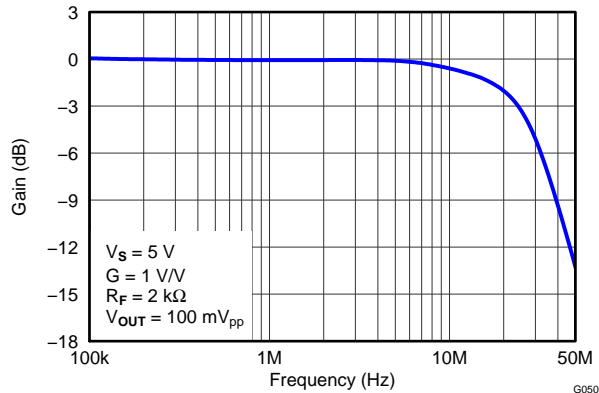

Figure 59.

V_{OCM} LARGE- and SMALL SIGNAL PULSE RESPONSE

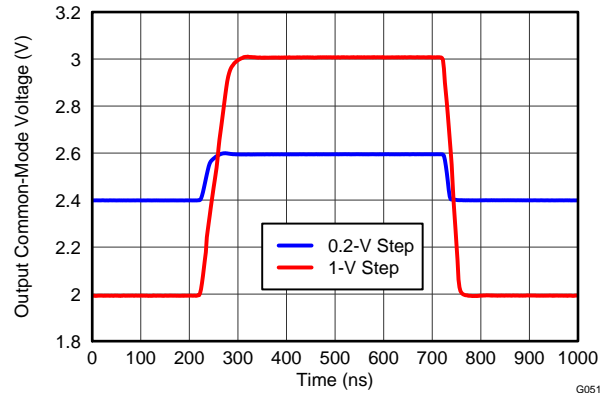

Figure 60.

TYPICAL CHARACTERISTICS: $V_S = 5V$ (continued)

Test conditions unless otherwise noted: $V_{S+} = 5V$, $V_{S-} = 0V$, $V_{OCM} = \text{open}$, $V_{OUT} = 2V_{pp}$, $R_F = 2k\Omega$, $R_L = 2k\Omega$ Differential, $G = 1V/V$, Single-Ended Input, Differential Output, Input and Output Referenced to mid-supply, $T_A = 25^\circ\text{C}$ unless otherwise noted.

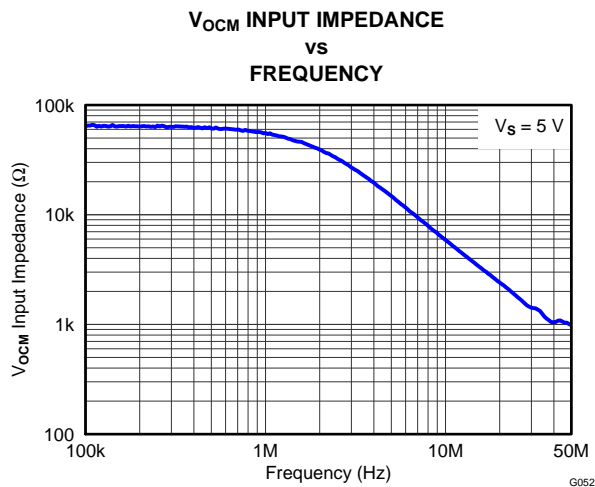

Figure 61.

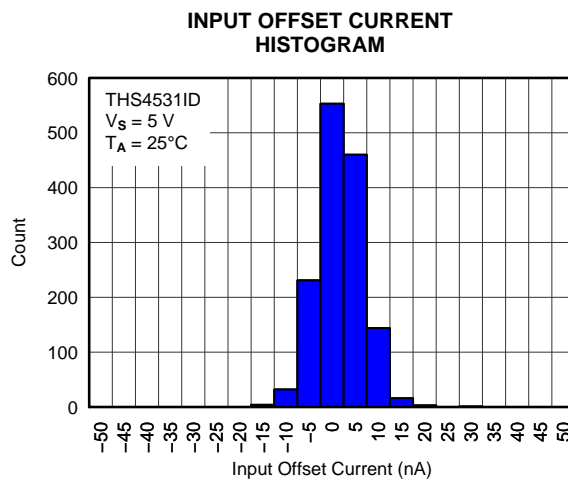

Figure 62.

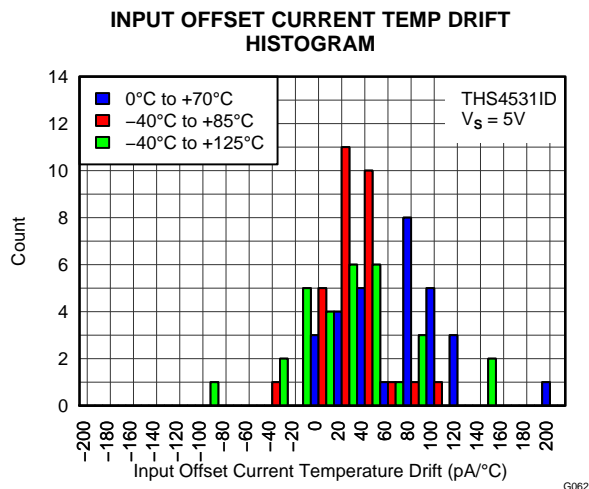

Figure 63.

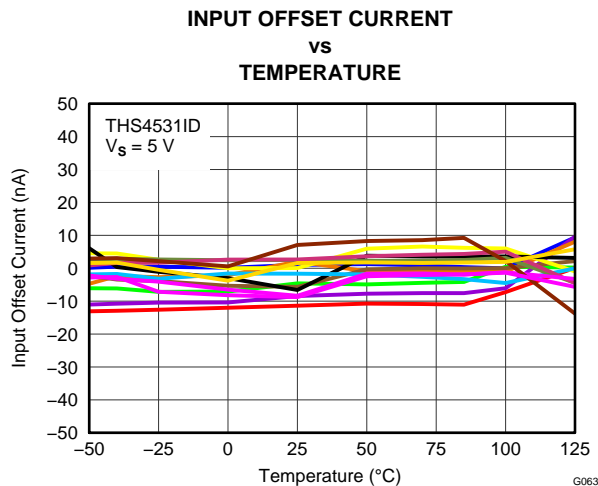

Figure 64.

TYPICAL CHARACTERISTICS: $V_S = 5V$ (continued)

Test conditions unless otherwise noted: $V_{S+} = 5V$, $V_{S-} = 0V$, $V_{OCM} = \text{open}$, $V_{OUT} = 2V_{pp}$, $R_F = 2k\Omega$, $R_L = 2k\Omega$ Differential, $G = 1V/V$, Single-Ended Input, Differential Output, Input and Output Referenced to mid-supply, $T_A = 25^\circ C$ unless otherwise noted.

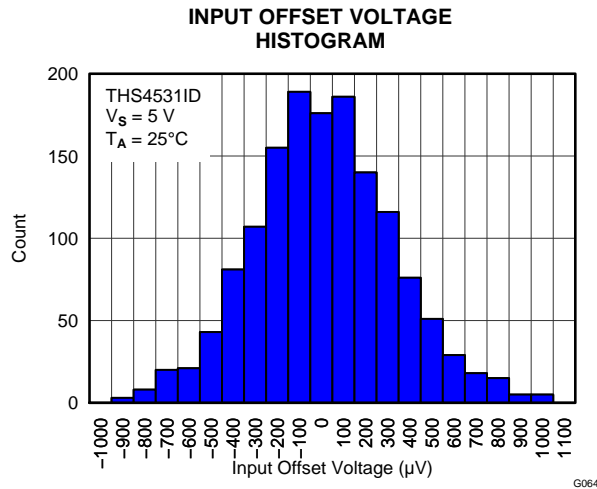

Figure 65.

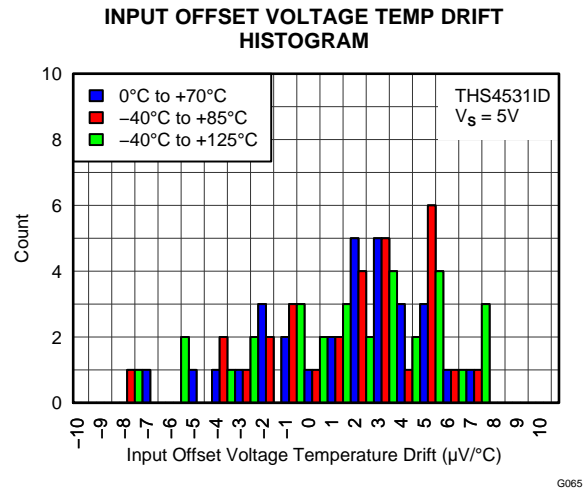

Figure 66.

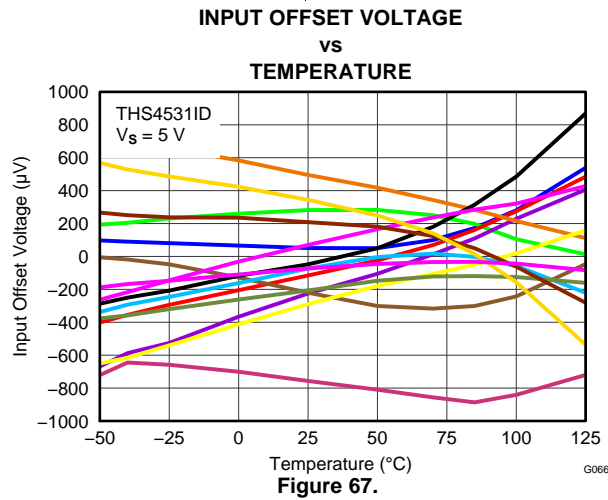

Figure 67.

APPLICATION INFORMATION

TYPICAL CHARACTERISTICS TEST CIRCUITS

Figure 68 shows the general test circuit built on the EVM that was used for testing the THS4531. For simplicity, power supply decoupling is not shown – please see layout in the applications section for recommendations. Depending on the test conditions, component values are changed per Table 2 and Table 3, or as otherwise noted. Some of the signal generators used are ac coupled 50Ω sources and a 0.22μF cap and 49.9Ω resistor to ground are inserted across R_{IT} on the un-driven or alternate input as shown to balance the circuit. Split-power supply is used to ease the interface to common lab test equipment, but if properly biased, the amplifier can be operated single-supply as described in the applications section with no impact on performance. For most of the tests, the devices are tested with single ended input and a transformer on the output to convert the differential output to single ended because common lab test equipment have single ended inputs and outputs. Performance is the same or better with differential input and differential output.

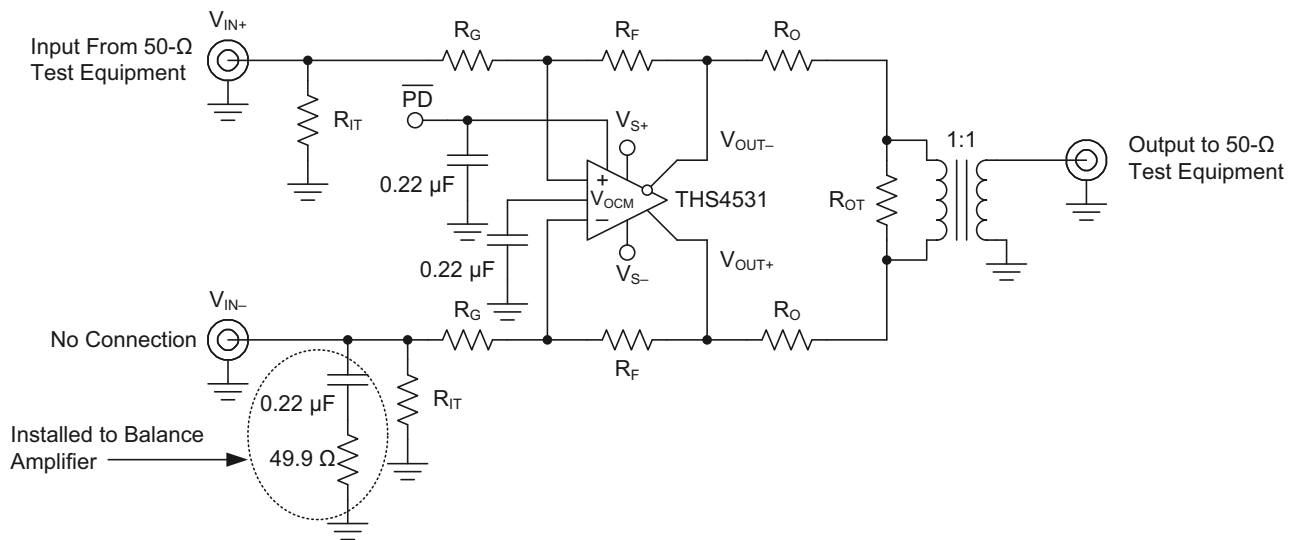

Figure 68. General Test Circuit

Table 2. Gain Component Values for Single-Ended Input⁽¹⁾

GAIN	R_F	R_G	R_{IT}
1 V/V	2kΩ	2kΩ	51.1Ω
2 V/V	2kΩ	1kΩ	52.3Ω
5 V/V	2kΩ	392Ω	53.6Ω
10 V/V	2kΩ	187kΩ	57.6Ω

(1) Note components are chosen to achieve gain and 50Ω input termination. Resistor values shown are closest standard values so gains are approximate.

Table 3. Load Component Values For 1:1 Differential to Single-Ended Output Transformer⁽¹⁾

R_L	R_O	R_{OT}	ATTEN
100Ω	25Ω	open	6
200Ω	86.6Ω	69.8Ω	16.8
499Ω	237Ω	56.2Ω	25.5
1kΩ	487Ω	52.3Ω	31.8
2kΩ	976Ω	51.1Ω	37.9

(1) Note the total load includes 50Ω termination by the test equipment. Components are chosen to achieve load and 50Ω line termination through a 1:1 transformer. Resistor values shown are closest standard values so loads are approximate.

Due to the voltage divider on the output formed by the load component values, the amplifier's output is attenuated. The column "Atten" in [Table 3](#) shows the attenuation expected from the resistor divider. When using a transformer at the output as shown in [Figure 68](#), the signal will see slightly more loss due to transformer and line loss, and these numbers will be approximate. The standard output load used for most tests is 2k Ω with associated 37.9dB of loss.

Frequency Response, and Output Impedance

The circuit shown in [Figure 68](#) is used to measure the frequency response of the amplifier.

A network analyzer is used as the signal source and the measurement device. The output impedance of the network analyzer is 50 Ω and is DC coupled. R_{IT} and R_G are chosen to impedance match to 50 Ω and maintain the proper gain. To balance the amplifier, a 49.9 Ω resistor to ground is inserted across R_{IT} on the alternate input.

The output is routed to the input of the network analyzer via 50 Ω coax. For 2k load, 37.9dB is added to the measurement to refer back to the amplifier's output per [Table 3](#).

For output impedance, the signal is injected at V_{OUT} with V_{IN} left open. The voltage drop across the 2x R_O resistors is measured with a high impedance differential probe and used to calculate the impedance seen looking into the amplifier's output.

Distortion

At 1MHz and above, the circuit shown in [Figure 68](#) is used to measure harmonic, intermodulation distortion, and output impedance of the amplifier.

A signal generator is used as the signal source and the output is measured with a spectrum analyzer. The output impedance of the signal generator is 50 Ω and is AC coupled. R_{IT} and R_G are chosen to impedance match to 50 Ω and maintain the proper gain. To balance the amplifier, a 0.22 μ F cap and 49.9 Ω resistor to ground is inserted across R_{IT} on the alternate input. A low-pass filter is inserted in series with the input to reduce harmonics generated at the signal source. The level of the fundamental is measured and then a high-pass filter is inserted at the output to reduce the fundamental so it does not generate distortion in the input of the spectrum analyzer.

Distortion in the audio band is measured using an audio analyzer. Refer to audio measurement section for detail.

Slew Rate, Transient Response, Settling Time, Overdrive, Output Voltage, and Turn-On/Off Time

The circuit shown in [Figure 69](#) is used to measure slew rate, transient response, settling time, overdrive recovery, and output voltage swing. Turn on and turn off times are measured with 50 Ω input termination on the \overline{PD} input, by replacing the 0.22 μ F capacitor with 49.9 Ω resistor.

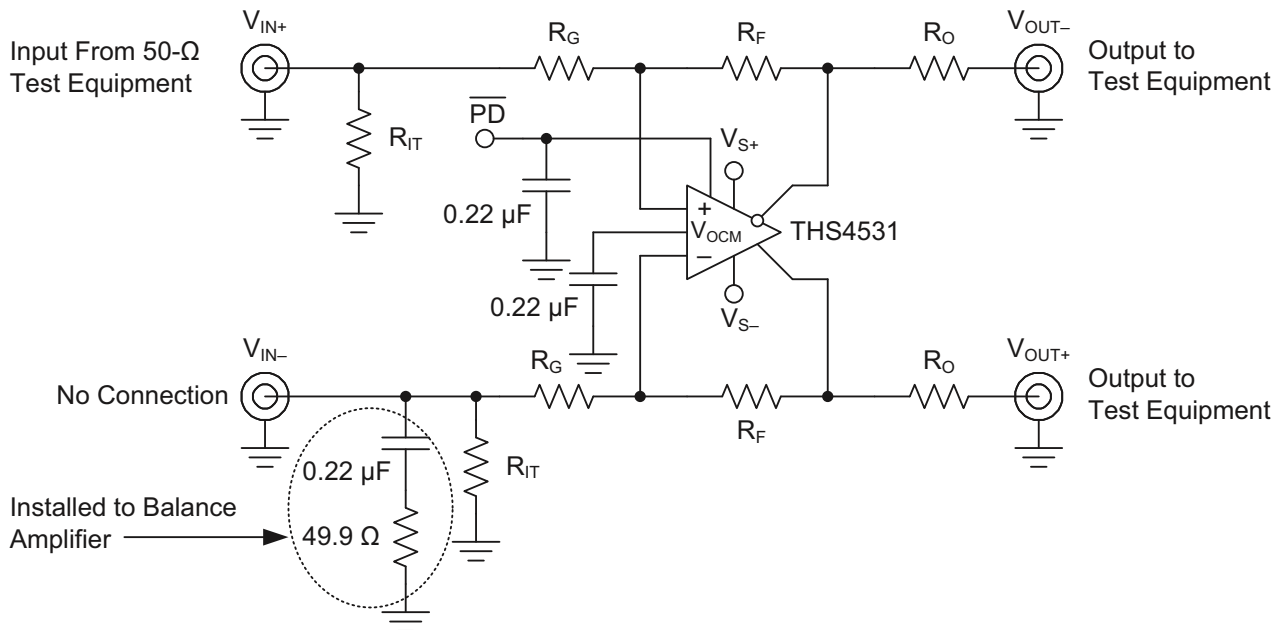

Figure 69. Slew Rate, Transient Response, Settling Time, Z_O , Overdrive Recovery, V_{OUT} Swing, and Turn-on/off Test Circuit

Common-Mode and Power Supply Rejection

The circuit shown in Figure 70 is used to measure the CMRR. The signal from the network analyzer is applied common-mode to the input.

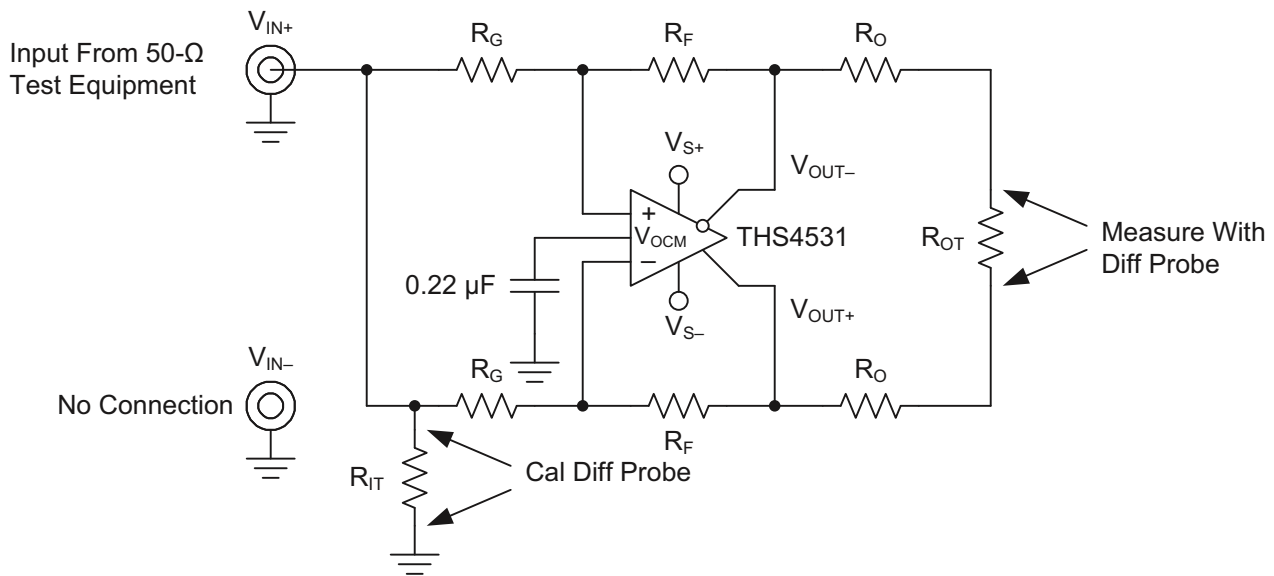

Figure 70. CMRR Test Circuit

Figure 71 is used to measure the PSRR of V_{S+} and V_{S-} . The power supply is applied to the network analyzer's DC offset input. For both CMRR and PSRR, the output is probed using a high impedance differential probe across R_{OT} .

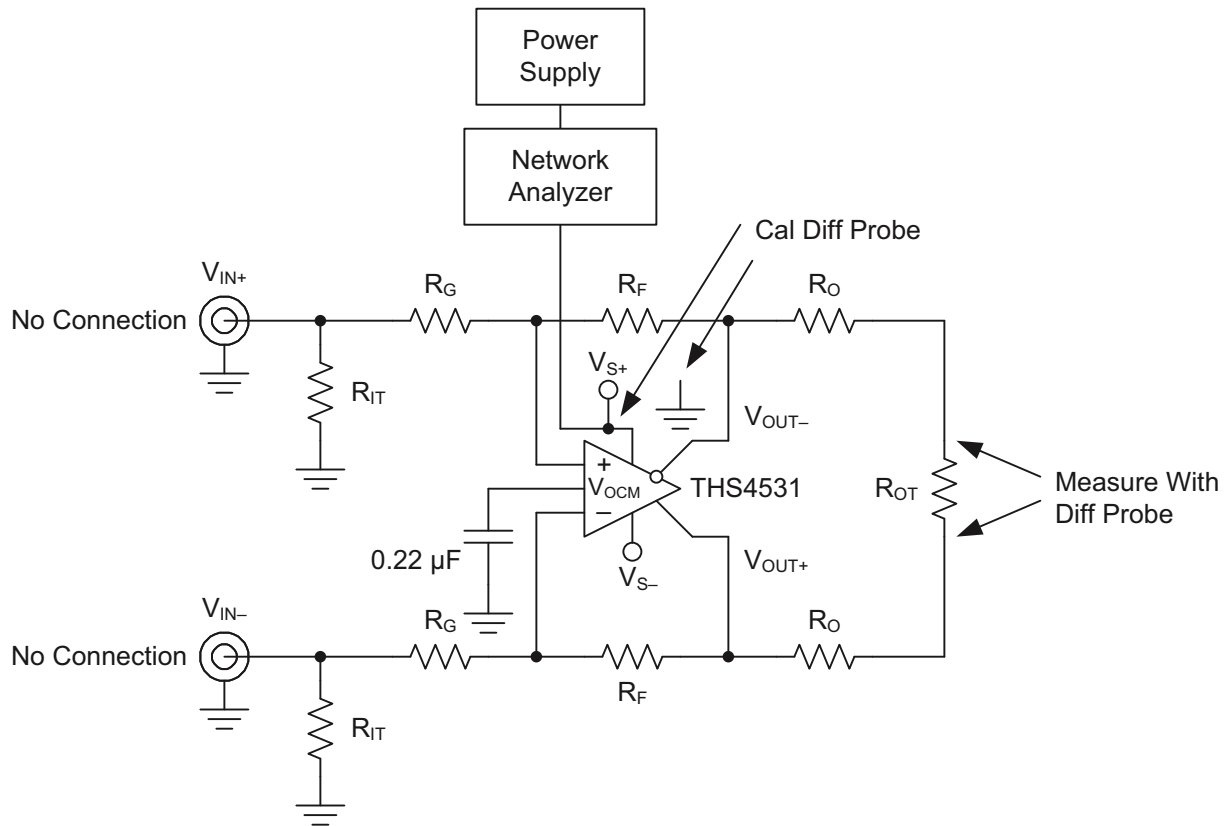

Figure 71. PSRR Test Circuit

V_{OCM} Input

The circuit shown in Figure 72 is used to measure the transient response, frequency response and input impedance of the V_{OCM} input. For these tests, the cal point is across the 49.9Ω V_{OCM} termination resistor. Transient response and frequency response are measured with R_{CM} = 0Ω and using a high impedance differential probe at the summing junction of the two R_O resistors, with respect to ground. The input impedance is measured using a high impedance differential probe at the V_{OCM} pin and the drop across R_{CM} is used to calculate the impedance seen looking into the amplifier's V_{OCM} input.

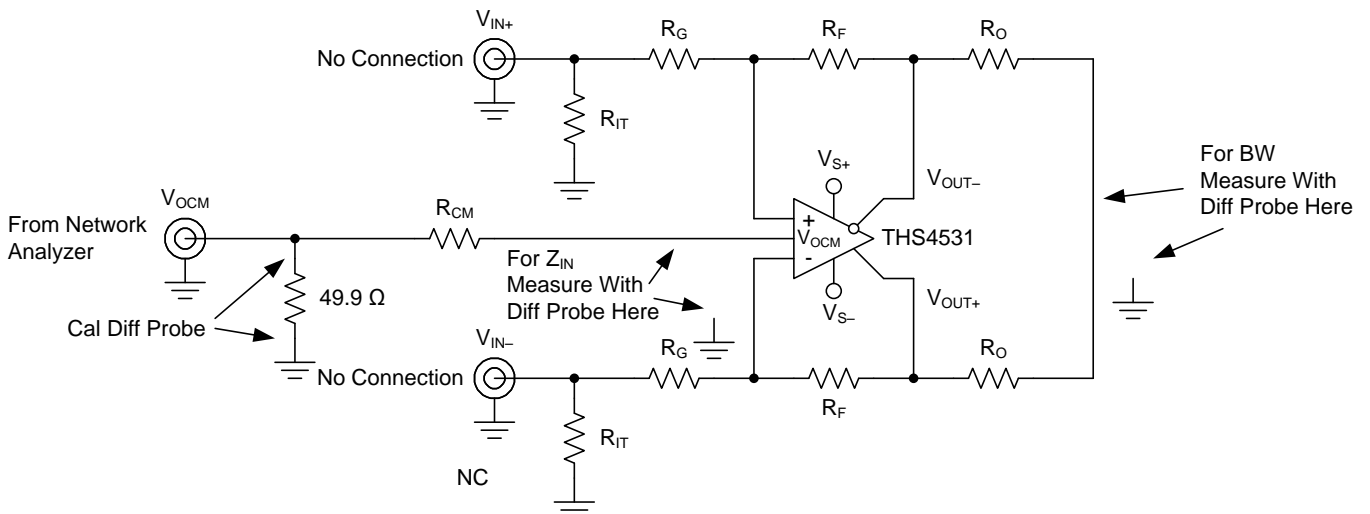

Figure 72. V_{OCM} Input Test Circuit

Balance Error

The circuit shown in Figure 73 is used to measure the balance error of the main differential amplifier. A network analyzer is used as the signal source and the measurement device. The output impedance of the network analyzer is 50Ω and is DC coupled. R_{IT} and R_G are chosen to impedance match to 50Ω and maintain the proper gain. To balance the amplifier, a 49.9Ω resistor to ground is inserted across R_{IT} on the alternate input. The output is measured using a high impedance differential probe at the summing junction of the two R_O resistors, with respect to ground.

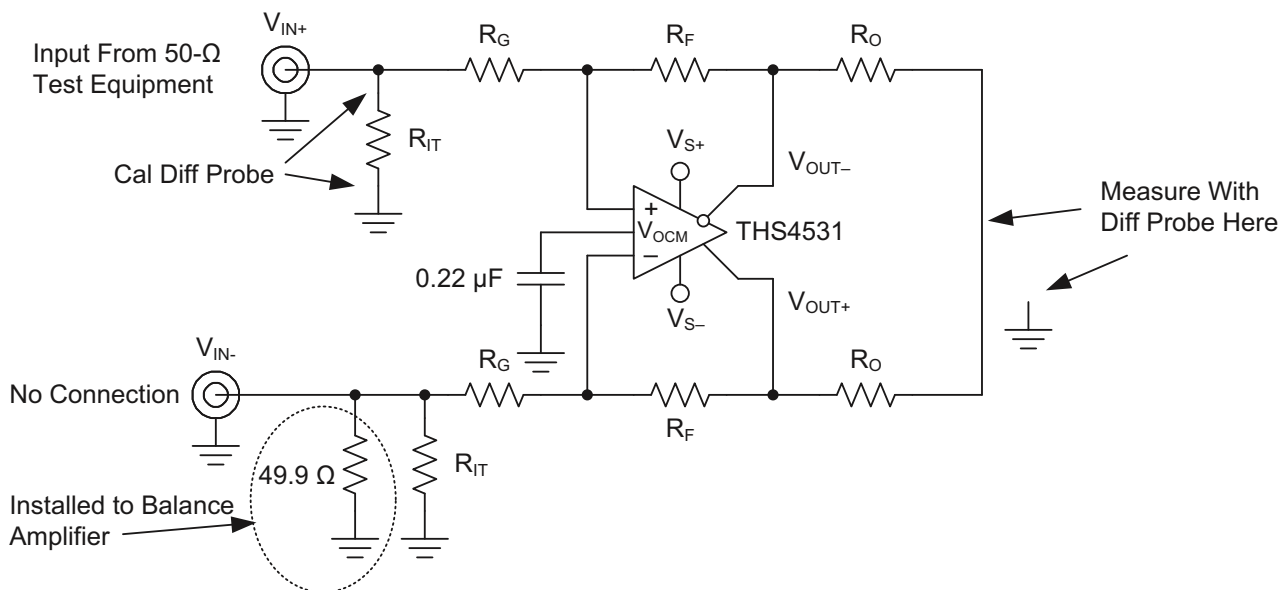

Figure 73. Balance Error Test Circuit

APPLICATION CIRCUITS

The following circuits show application information for the THS4531. For simplicity, power supply decoupling capacitors are not shown in these diagrams – please see the EVM and Layout Recommendations section for recommendations. For more detail on the use and operation of fully differential op amps refer to application report “Fully-Differential Amplifiers” [SLOA054D](#).

Differential Input to Differential Output Amplifier

The THS4531 is a fully differential op amp and can be used to amplify differential input signals to differential output signals. A basic block diagram of the circuit is shown in [Figure 74](#) (V_{OCM} and PD inputs not shown). The gain of the circuit is set by R_F divided by R_G .

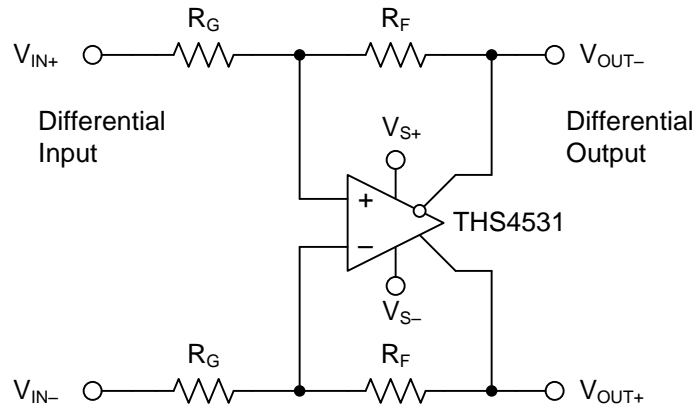

Figure 74. Differential Input to Differential Output Amplifier

Single-Ended Input to Differential Output Amplifier

The THS4531 can also be used to amplify and convert single-ended input signals to differential output signals. A basic block diagram of the circuit is shown in [Figure 75](#) (V_{OCM} and PD inputs not shown). The gain of the circuit is again set by R_F divided by R_G .

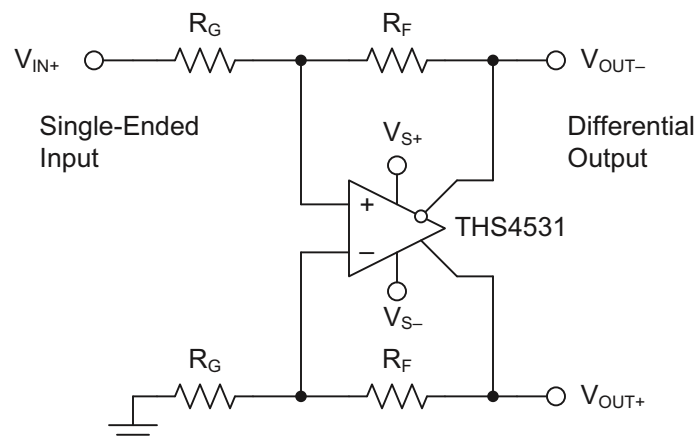

Figure 75. Single-Ended Input to Differential Output Amplifier

Differential Input to Single-Ended Output Amplifier

Fully differential op amps like the THS4531 are not recommended for differential to single-ended conversion. This application is best performed with an instrumentation amplifier or with a standard op amp configured as a classic differential amplifier. See application section of the OPA835 data sheet ([SLOS713](#)).

Input Common-Mode Voltage Range

The input common-mode voltage of a fully differential op amp is the voltage at the “+ and –” input pins of the op amp.

It is important to not violate the input common-mode voltage range (V_{ICR}) of the op amp. Assuming the op amp is in linear operation the voltage across the input pins is only a few millivolts at most. So finding the voltage at one input pin will determine the input common-mode voltage of the op amp.

Treating the negative input as a summing node, the voltage is given by:

$$\left(V_{OUT+} \times \frac{R_G}{R_G + R_F} \right) + \left(V_{IN-} \times \frac{R_F}{R_G + R_F} \right) \quad (1)$$

To determine the V_{ICR} of the op amp, the voltage at the negative input is evaluated at the extremes of V_{OUT+} .

As the gain of the op amp increases, the input common-mode voltage becomes closer and closer to the input common-mode voltage of the source.

Setting the Output Common-Mode Voltage

The output common-mode voltage is set by the voltage at the V_{OCM} pin and the internal circuit works to maintain the output common-mode voltage as close as possible to this voltage. If left unconnected, the output common-mode is set to mid-supply by internal circuitry, which may be over-driven from an external source. Figure 76 is representative of the V_{OCM} input. The internal V_{OCM} circuit has about 24MHz of -3dB bandwidth, which is required for best performance, but it is intended to be a DC bias input pin. Bypass capacitors are recommended on this pin to reduce noise. The external current required to overdrive the internal resistor divider is given approximately by the formula:

$$I_{EXT} = \frac{2V_{OCM} - (V_{S+} - V_{S-})}{60k\Omega} \quad (2)$$

where V_{OCM} is the voltage applied to the V_{OCM} pin.

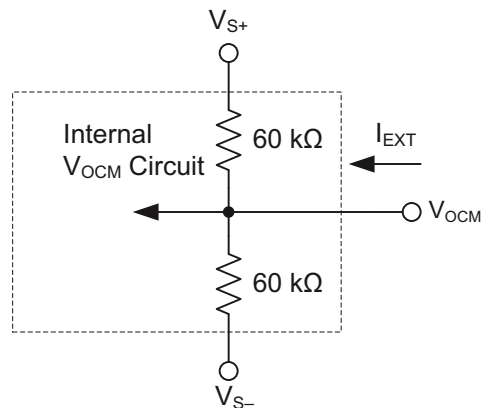

Figure 76. Simplified V_{OCM} Input Circuit

Single-Supply Operation

To facilitate testing with common lab equipment, the THS4531 EVM is built to allow for split-supply operation and most of the data presented in this data sheet was taken with split-supply power inputs. But the device is designed for use with single-supply power operation and can easily be used with single-supply power without degrading the performance. The only requirement is to bias the device properly and the specifications in this data sheet are given for single supply operation.

Low Power Applications and the Effects of Resistor Values on Bandwidth

The THS4531 is designed for the nominal value of R_F to be 2 k Ω . This gives excellent distortion performance, maximum bandwidth, best flatness, and best pulse response. It also loads the amplifier. For example; in gain of 1 with $R_F = R_G = 2$ k Ω , R_G to ground, and $V_{OUT+} = 4V$, 1mA of current will flow through the feedback path to ground. In low power applications, it is desirable to reduce this current by increasing the gain setting resistors values. Using larger value gain resistors has two primary side effects (other than lower power) due to their interaction with the device and PCB parasitic capacitance:

1. Lowers the bandwidth.
2. Lowers the phase margin
 - (a) This will cause peaking in the frequency response.
 - (b) And will cause over shoot and ringing in the pulse response.

Figure 77 shows the small signal frequency response for gain of 1 with R_F and R_G equal to 2k Ω , 10k Ω , and 100k Ω . The test was done with $R_L = 2$ k Ω . Due to loading effects of R_L , lower values may reduce the peaking, but higher values will not have a significant effect.

As expected, larger value gain resistors cause lower bandwidth and peaking in the response (peaking in frequency response is synonymous with overshoot and ringing in pulse response).

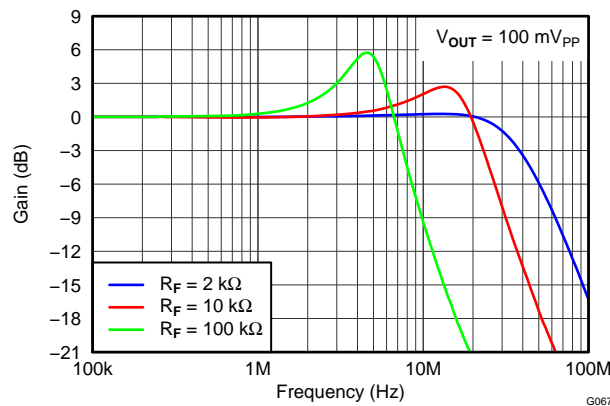

Figure 77. THS4531 Frequency Response with Various Gain Setting Resistor Values

Driving Capacitive Loads

The THS4531 is designed for a nominal capacitive load of 2pF (differentially). When driving capacitive loads greater than this, it is recommended to use small resistors (R_O) in series with the output as close to the device as possible. Without R_O , capacitance on the output will interact with the output impedance of the amplifier causing phase shift in the loop gain of the amplifier that will reduce the phase margin resulting in:

1. Peaking in the frequency response.
2. Overshoot, undershoot, and ringing in the time domain response with a pulse or square-wave signal.
3. May lead to instability or oscillation.

Inserting R_O will compensate the phase shift and restore the phase margin, but it will also limit bandwidth. The circuit shown in Figure 69 is used to test for best R_O versus capacitive loads, C_L , with a capacitance placed differential across the V_{OUT+} and V_{OUT-} along with 2k Ω load resistor, and the output is measure with a differential probe. Figure 78 shows the optimum values of R_O versus capacitive loads, C_L , and Figure 79 shows the frequency response with various values. Performance is the same on both 2.7V and 5V supply.

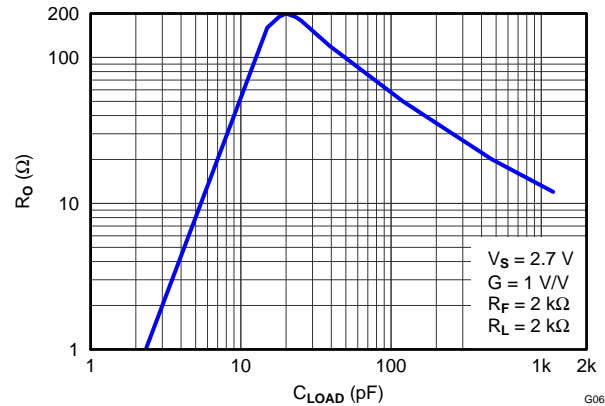

Figure 78. Recommended Series Output Resistor vs Capacitive Load for Flat Frequency Response

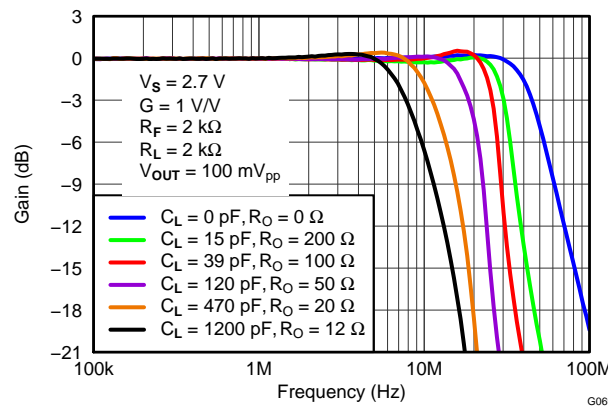

Figure 79. Frequency Response for Various R_O and C_L Values

Audio Performance

The THS4531 provides excellent audio performance with very low quiescent power. To show performance in the audio band, the device was tested with an audio analyzer. THD+N and FFT tests were run at 1V_{rms} output voltage. Performance is the same on both 2.7V and 5V supply. Figure 80 is the test circuit used, and Figure 81 and Figure 82 show performance of the analyzer. In the FFT plot the harmonic spurs are at the testing limit of the analyzer, which means the THS4531 is actually much better than can be directly measured. Because the THS4531 distortion performance cannot be directly measured in the audio band it is estimated from measurement in high noise gain configuration correlated with simulation.

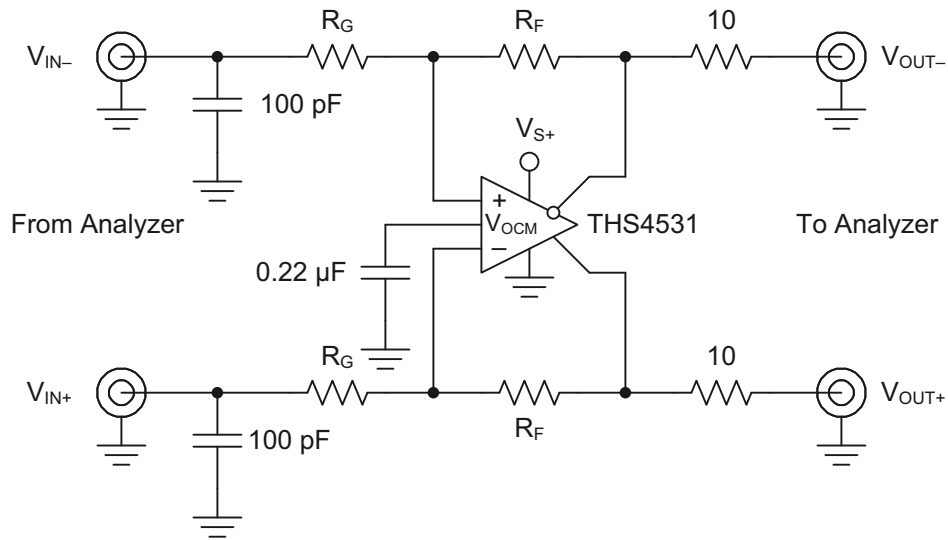

Figure 80. THS4531 Audio Analyzer Test Circuit

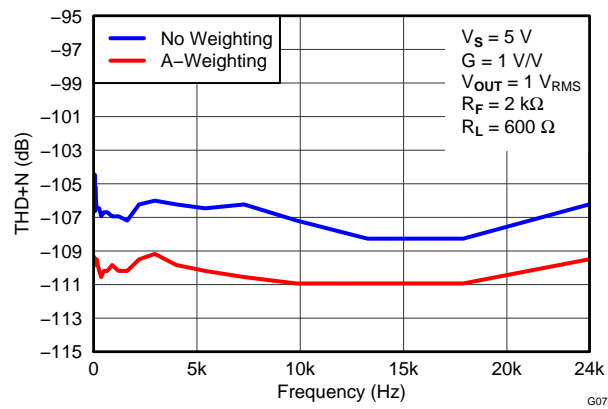

Figure 81. THD+N on Audio Analyzer, 10 Hz to 24 kHz

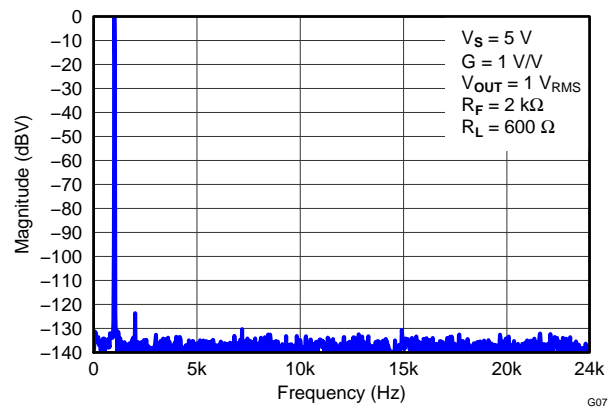

Figure 82. 1kHz FFT Plot on Audio Analyzer

Audio On/Off Pop Performance

The THS4531 is tested to show on and off pop performance by connecting a speaker between the differential outputs and switching on and off the power supply, and also by using the power down function of the THS4531. Testing was done with and without tones. During these tests no audible pop could be heard.

With no input tone, Figure 83 shows the voltage waveforms when switching power on to the THS4531 and Figure 84 shows voltage waveforms when turning power off. The transients during power on and off show no audible pop should be heard.

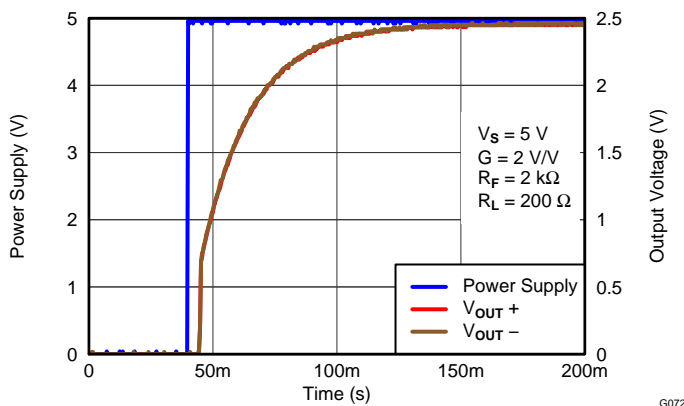

Figure 83. Power Supply Turn On Pop Performance

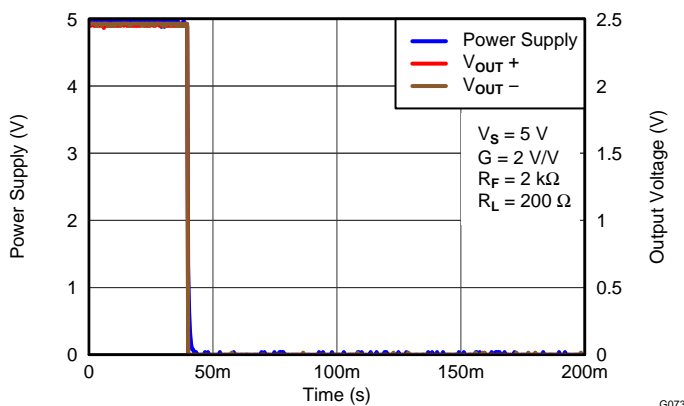

Figure 84. Power Supply Turn Off Pop Performance

With no input tone, Figure 85 shows the voltage waveforms using the $\overline{\text{PD}}$ pin to enable and disable the THS4531. The transients during power on and off show no audible pop should be heard.

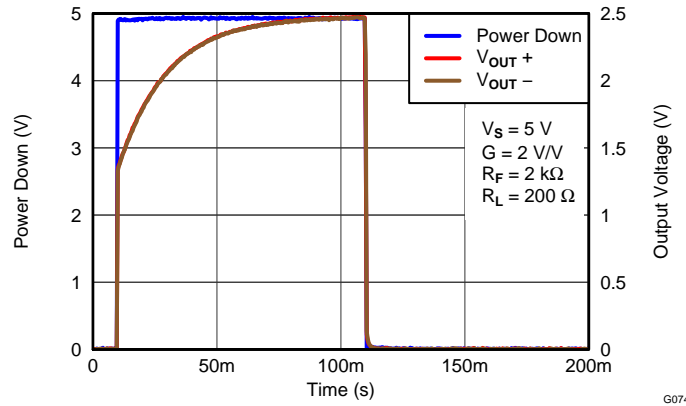

Figure 85. PD Enable Pop Performance

AUDIO ADC DRIVER PERFORMANCE: THS4531 AND PCM4204 COMBINED PERFORMANCE

To show achievable performance with a high performance audio ADC, the THS4531 is tested as the drive amplifier for the PCM4204. The PCM4204 is a high-performance, four-channel analog-to-digital (A/D) converter designed for professional and broadcast audio applications. The PCM4204 architecture utilizes a 1-bit delta-sigma modulator per channel incorporating an advanced dither scheme for improved dynamic performance, and supports PCM output data. The PCM4204 provides flexible serial port interface and many other advanced features. Please refer to its data sheet for more information.

The PCM4204 EVM is used to test the audio performance of the THS4531 as a drive amplifier. The standard PCM4204 EVM is provided with 4x OPA1632 fully differential amplifiers, which use the same pin out as the THS4531. For testing, one of these amplifiers is replaced with a THS4531 device in same package (MSOP), gain changed to 1V/V, and power supply changed to single supply +5V. Figure 86 shows the circuit. With single supply +5V supply the output common-mode of the THS4531 defaults to +2.5V as required at the input of the PCM4204. So the resistor connecting the V_{OCM} input of the THS4531 to the input common-mode drive from the PCM4204 is optional and no performance change was noted with it connected or removed. The EVM power connections were modified by connecting positive supply inputs, +15V, +5VA and +5VD, to a +5V external power supply (EXT +3.3 was not used) and connecting -15V and all ground inputs to ground on the external power supply so only one external +5V supply was needed to power all devices on the EVM.

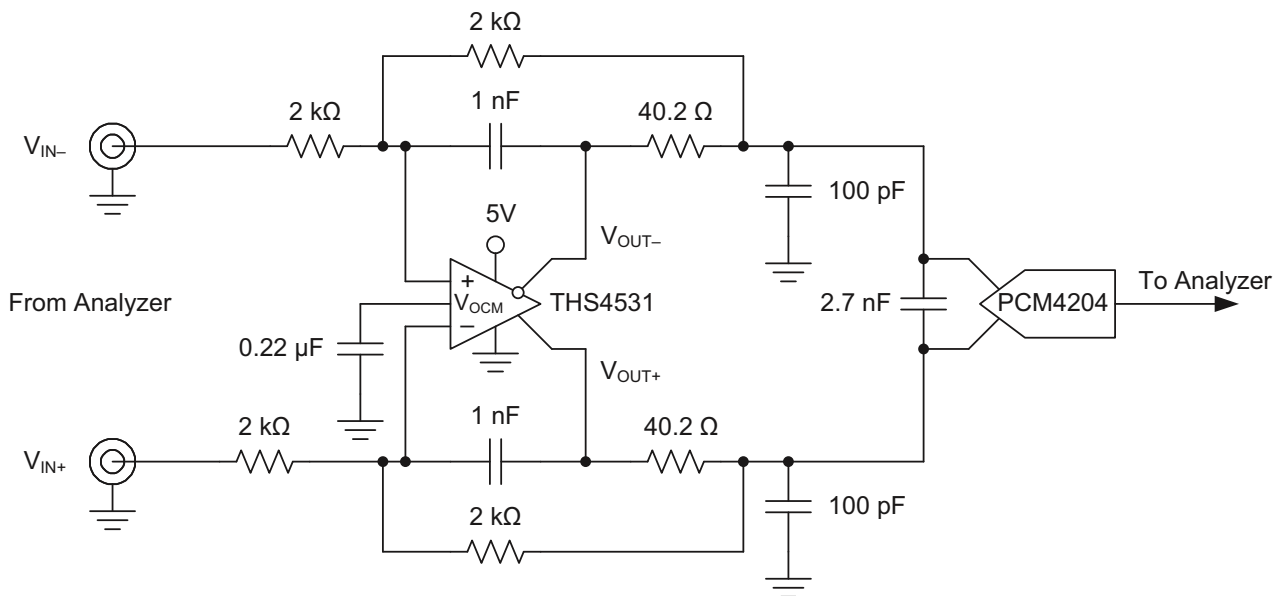

Figure 86. THS4531 and PCM4204 Test Circuit

An audio analyzer is used to provide an analog audio input to the EVM and the PCM formatted digital output is read by the digital input on the analyzer. Data was taken at $f_s = 96\text{kHz}$, and audio output uses PCM format. Other data rates and formats are expected to show similar performance in line with that shown in the data sheet.

Figure 87 shows the THD+N vs Frequency with no weighting and Figure 88 shows an FFT with 1kHz input tone. Input signal to the PCM4204 for these tests is -0.5dBFS. Table 4 summarizes results of testing using the THS4531 + PCM4204 versus typical Data Sheet performance, and show it make an excellent drive amplifier for this ADC.

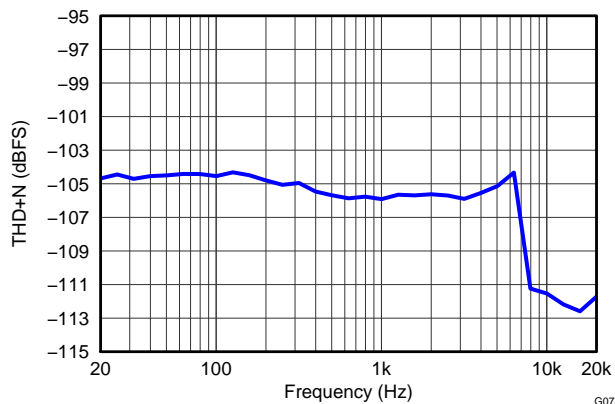

Figure 87. THS4531 + PCM4204 THD+N vs Frequency with No Weighting

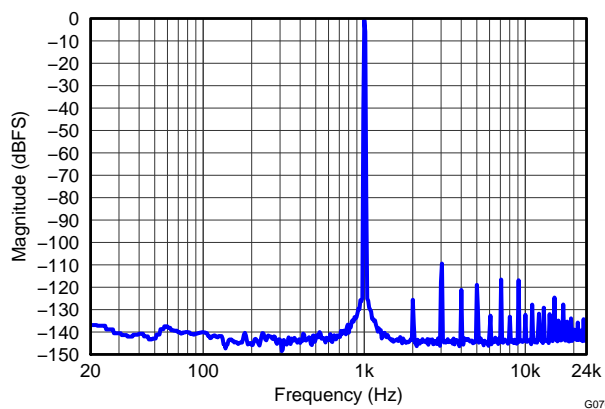

Figure 88. THS4531 + PCM4204 1kHz FFT

Table 4. 1kHz AC Analysis: Test Circuit versus PCM4204 Data Sheet Typical Specifications ($f_s = 96\text{kSPS}$)

CONFIGURATION	TONE	THD + N
THS4531 + PCM4204	1kHz	-106 dB
PCM4204 Data Sheet (typ)	1kHz	-103 dB

SAR ADC PERFORMANCE

THS4531 and ADS8321 Combined Performance

To show achievable performance with a high performance SAR ADC, the THS4531 is tested as the drive amplifier for the ADS8321. The ADS8321 is a 16-bit, SAR ADC that offers excellent AC and DC performance, with ultra-low power and small size. The circuit shown in Figure 89 is used to test the performance. Data was taken using the ADS8321 at 100kSPS with input frequency of 10 kHz and signal levels 0.5 dB below full scale. The FFT plot of the spectral performance is in Figure 90. A summary of the FFT analysis results are in Table 5 along with ADS8321 typical data sheet performance at $f_s = 100\text{kSPS}$. Please refer to its data sheet for more information.

The standard ADS8321 EVM and THS4531 EVM are modified to implement the schematic in [Figure 89](#) and used to test the performance of the THS4531 as a drive amplifier. With single supply +5V supply the output common-mode of the THS4531 defaults to +2.5V as required at the input of the ADS8321 so the V_{OCM} input of the THS4531 simply bypassed to GND with 0.22 μ F capacitor. The summary of results of the FFT analysis versus typical data sheet performance shown in [Table 5](#) show the THS4531 will make an excellent drive amplifier for this ADC.

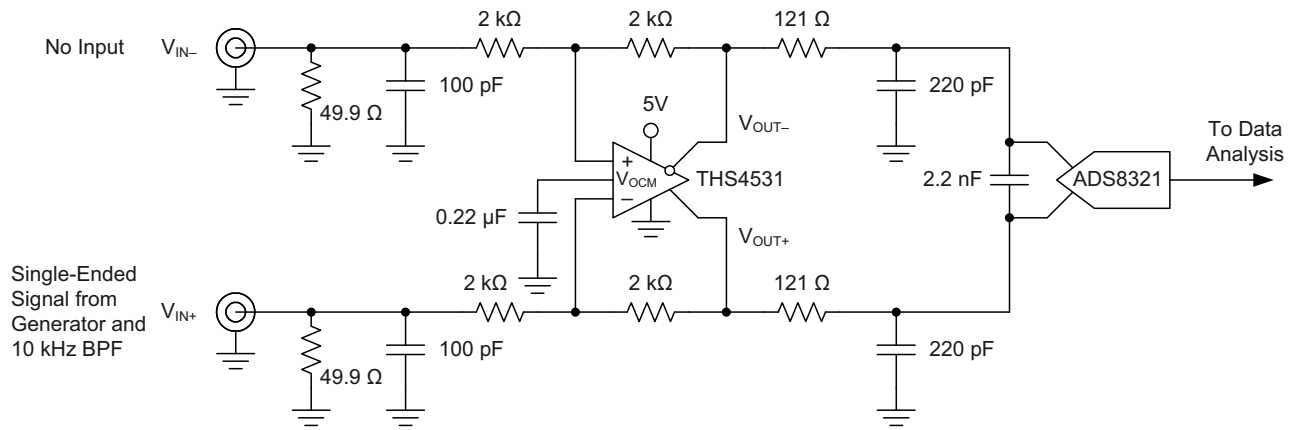

Figure 89. THS4531 and ADS8321 Test Circuit

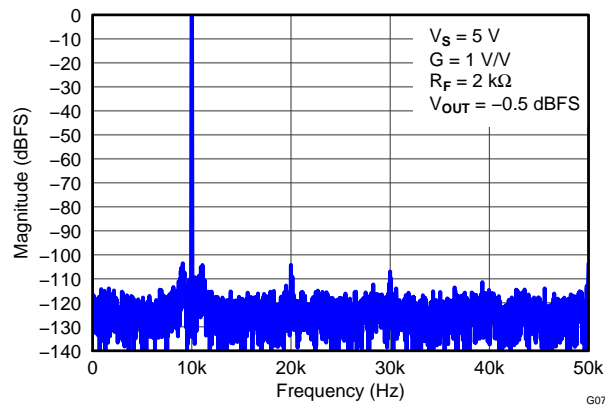

Figure 90. THS4531 + ADS8321 1kHz FFT

Table 5. 10kHz FFT Analysis Summary

CONFIGURATION	TONE	SIGNAL	SNR	THD	SINAD	SFDR
THS4531 + ADS8321	10kHz	-0.5 dBFS	87 dBc	-96 dBc	87 dBc	100 dBc
ADS8321 Data Sheet (typ)	10kHz	-0.5 dBFS	87 dBc	-86 dBc	84 dBc	86 dBc

THS4531 and ADS7945 Combined Performance

To show achievable performance with a high performance SAR ADC, the THS4531 is tested as the drive amplifier for the ADS7945. The ADS7945 is a 14-bit, SAR ADC that offers excellent AC and DC performance, with low power and small size. The circuit shown in [Figure 91](#) is used to test the performance. Data was taken using the ADS7945 at 2MSPS with input frequency of 10 kHz and signal level 0.5 dB below full scale. The FFT plot of the spectral performance is in [Figure 92](#). A summary of the FFT analysis results are in [Table 6](#) along with ADS7945 typical data sheet performance at $f_s = 2$ MSPS. Please refer to its data sheet for more information.

The standard ADS7945 EVM and THS4531 EVM are modified to implement the schematic in Figure 91 and used to test the performance of the THS4531 as a drive amplifier. With single supply +5V supply the output common-mode of the THS4531 defaults to +2.5V as required at the input of the ADS7945 so the V_{OCM} input of the THS4531 simply bypassed to GND with 0.22 μ F capacitor. The summary of results of the FFT analysis versus typical data sheet performance shown in Table 6 show the THS4531 will make an excellent drive amplifier for this ADC.

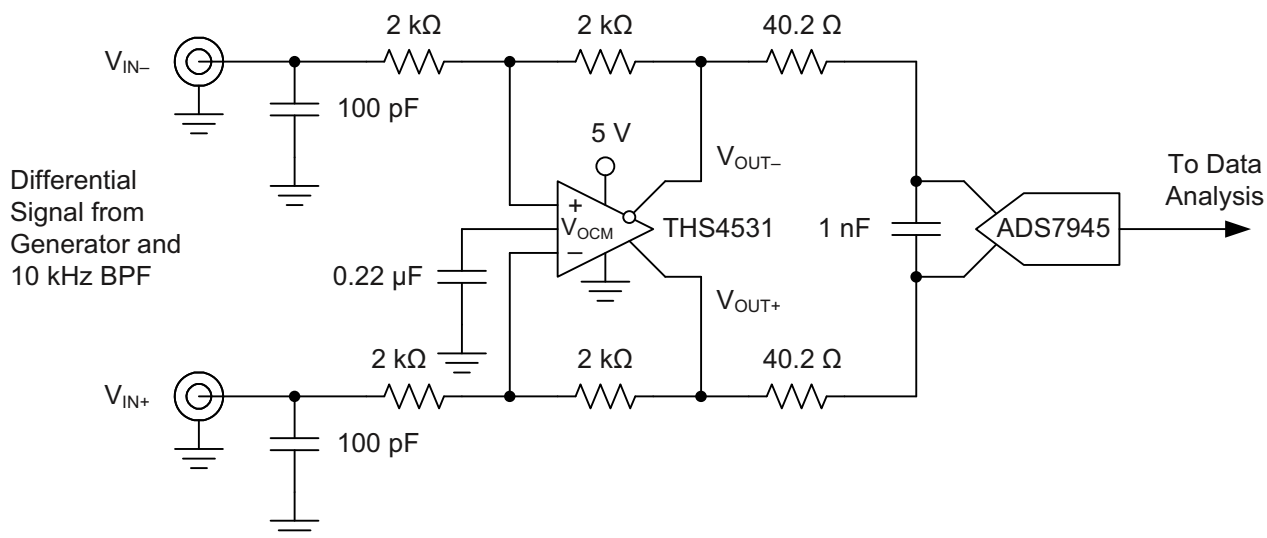

Figure 91. THS4531 and ADS7945 Test Circuit

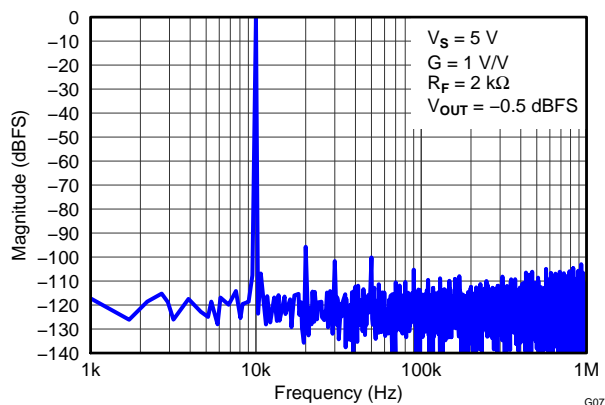

Figure 92. THS4531 and ADS7945 Test Circuit

Table 6. 10kHz FFT Analysis Summary

CONFIGURATION	TONE	SIGNAL	SNR	THD	SFDR
THS4531 + ADS7945	10kHz	-0.5 dBFS	83 dBc	-93 dBc	96 dBc
ADS7945 Data Sheet (typ)	10kHz	-0.5 dBFS	84 dBc	-92 dBc	94 dBc

EVM AND LAYOUT RECOMMENDATIONS

The THS4531 EVM ([SLOU334](#)) should be used as a reference when designing the circuit board. It is recommended to follow the EVM layout of the external components near to the amplifier, ground plane construction, and power routing as closely as possible. General guidelines are:

1. Signal routing should be direct and as short as possible into and out of the op amp.
2. The feedback path should be short and direct avoiding vias if possible.
3. Ground or power planes should be removed from directly under the amplifier's input and output pins.
4. A series output resistor is recommended to be placed as near to the output pin as possible. See [Figure 78](#) "Recommended Series Output Resistor vs. Capacitive Load" for recommended values given expected capacitive load of design.
5. A 2.2 μ F power supply decoupling capacitor should be placed within 2 inches of the device and can be shared with other op amps. For split supply, a capacitor is required for both supplies.
6. A 0.1 μ F power supply decoupling capacitor should be placed as near to the power supply pins as possible. Preferably within 0.1 inch. For split supply, a capacitor is required for both supplies.
7. The $\overline{\text{PD}}$ pin uses TTL logic levels referenced to the negative supply voltage (V_{S}). When not used it should be tied to the positive supply to enable the amplifier. When used, it must be actively driven high or low and should not be left in an indeterminate logic state. A bypass capacitor is not required, but can be used for robustness in noisy environments.

REVISION HISTORY

NOTE: Page numbers for previous revisions may differ from page numbers in the current version.

Changes from Revision A (January 2012) to Revision B	Page
• Deleted DC Performance, <i>Input-referred offset voltage</i> parameter typical specifications for $T_A = 0^\circ\text{C}$ to $+70^\circ\text{C}$, -40°C to $+85^\circ\text{C}$, and -40°C to $+125^\circ\text{C}$ in 2.7 V Electrical Characteristics table	4
• Changed DC Performance, <i>Input-referred offset voltage</i> parameter maximum specifications for $T_A = 0^\circ\text{C}$ to $+70^\circ\text{C}$, -40°C to $+85^\circ\text{C}$, and -40°C to $+125^\circ\text{C}$ in 2.7 V Electrical Characteristics table	4
• Changed DC Performance, <i>Input offset voltage drift</i> parameter typical and maximum specifications in 2.7 V Electrical Characteristics table	4
• Deleted DC Performance, <i>Input bias current</i> parameter typical specifications for $T_A = 0^\circ\text{C}$ to $+70^\circ\text{C}$, -40°C to $+85^\circ\text{C}$, and -40°C to $+125^\circ\text{C}$ in 2.7 V Electrical Characteristics table	4
• Deleted DC Performance, <i>Input bias current drift</i> parameter typical specifications in 2.7 V Electrical Characteristics table	4
• Deleted DC Performance, <i>Input offset current</i> parameter typical specifications for $T_A = 0^\circ\text{C}$ to $+70^\circ\text{C}$, -40°C to $+85^\circ\text{C}$, and -40°C to $+125^\circ\text{C}$ in 2.7 V Electrical Characteristics table	4
• Deleted DC Performance, <i>Input-referred offset voltage</i> parameter typical specifications for $T_A = 0^\circ\text{C}$ to $+70^\circ\text{C}$, -40°C to $+85^\circ\text{C}$, and -40°C to $+125^\circ\text{C}$ in 5 V Electrical Characteristics table	7
• Changed DC Performance, <i>Input-referred offset voltage</i> parameter maximum specifications for $T_A = 0^\circ\text{C}$ to $+70^\circ\text{C}$, -40°C to $+85^\circ\text{C}$, and -40°C to $+125^\circ\text{C}$ in 5 V Electrical Characteristics table	7
• Changed DC Performance, <i>Input offset voltage drift</i> parameter typical specifications in 5 V Electrical Characteristics table	7
• Deleted DC Performance, <i>Input bias current</i> parameter typical specifications for $T_A = 0^\circ\text{C}$ to $+70^\circ\text{C}$, -40°C to $+85^\circ\text{C}$, and -40°C to $+125^\circ\text{C}$ in 5 V Electrical Characteristics table	7
• Deleted DC Performance, <i>Input offset current</i> parameter typical specifications for $T_A = 0^\circ\text{C}$ to $+70^\circ\text{C}$, -40°C to $+85^\circ\text{C}$, and -40°C to $+125^\circ\text{C}$ in 5 V Electrical Characteristics table	7

Changes from Original (SEPTEMBER 2011) to Revision A

Page

-
- Changed from product preview to production data 1
-

PACKAGING INFORMATION

Orderable Device	Status ⁽¹⁾	Package Type	Package Drawing	Pins	Package Qty	Eco Plan ⁽²⁾	Lead/ Ball Finish	MSL Peak Temp ⁽³⁾	Samples (Requires Login)
THS4531ID	ACTIVE	SOIC	D	8	75	Green (RoHS & no Sb/Br)	CU NIPDAU	Level-2-260C-1 YEAR	
THS4531IDGK	ACTIVE	MSOP	DGK	8	80	Green (RoHS & no Sb/Br)	CU NIPDAUAG	Level-2-260C-1 YEAR	
THS4531IDGKR	ACTIVE	MSOP	DGK	8	2500	Green (RoHS & no Sb/Br)	CU NIPDAUAG	Level-2-260C-1 YEAR	
THS4531IDR	ACTIVE	SOIC	D	8	2500	Green (RoHS & no Sb/Br)	CU NIPDAU	Level-2-260C-1 YEAR	
THS4531IRUNR	ACTIVE	QFN	RUN	10	3000	Green (RoHS & no Sb/Br)	CU NIPDAU	Level-2-260C-1 YEAR	
THS4531IRUNT	ACTIVE	QFN	RUN	10	250	Green (RoHS & no Sb/Br)	CU NIPDAU	Level-2-260C-1 YEAR	

⁽¹⁾ The marketing status values are defined as follows:

ACTIVE: Product device recommended for new designs.

LIFEBUY: TI has announced that the device will be discontinued, and a lifetime-buy period is in effect.

NRND: Not recommended for new designs. Device is in production to support existing customers, but TI does not recommend using this part in a new design.

PREVIEW: Device has been announced but is not in production. Samples may or may not be available.

OBSELETE: TI has discontinued the production of the device.

⁽²⁾ Eco Plan - The planned eco-friendly classification: Pb-Free (RoHS), Pb-Free (RoHS Exempt), or Green (RoHS & no Sb/Br) - please check <http://www.ti.com/productcontent> for the latest availability information and additional product content details.

TBD: The Pb-Free/Green conversion plan has not been defined.

Pb-Free (RoHS): TI's terms "Lead-Free" or "Pb-Free" mean semiconductor products that are compatible with the current RoHS requirements for all 6 substances, including the requirement that lead not exceed 0.1% by weight in homogeneous materials. Where designed to be soldered at high temperatures, TI Pb-Free products are suitable for use in specified lead-free processes.

Pb-Free (RoHS Exempt): This component has a RoHS exemption for either 1) lead-based flip-chip solder bumps used between the die and package, or 2) lead-based die adhesive used between the die and leadframe. The component is otherwise considered Pb-Free (RoHS compatible) as defined above.

Green (RoHS & no Sb/Br): TI defines "Green" to mean Pb-Free (RoHS compatible), and free of Bromine (Br) and Antimony (Sb) based flame retardants (Br or Sb do not exceed 0.1% by weight in homogeneous material)

⁽³⁾ MSL, Peak Temp. -- The Moisture Sensitivity Level rating according to the JEDEC industry standard classifications, and peak solder temperature.

Important Information and Disclaimer: The information provided on this page represents TI's knowledge and belief as of the date that it is provided. TI bases its knowledge and belief on information provided by third parties, and makes no representation or warranty as to the accuracy of such information. Efforts are underway to better integrate information from third parties. TI has taken and continues to take reasonable steps to provide representative and accurate information but may not have conducted destructive testing or chemical analysis on incoming materials and chemicals. TI and TI suppliers consider certain information to be proprietary, and thus CAS numbers and other limited information may not be available for release.

In no event shall TI's liability arising out of such information exceed the total purchase price of the TI part(s) at issue in this document sold by TI to Customer on an annual basis.

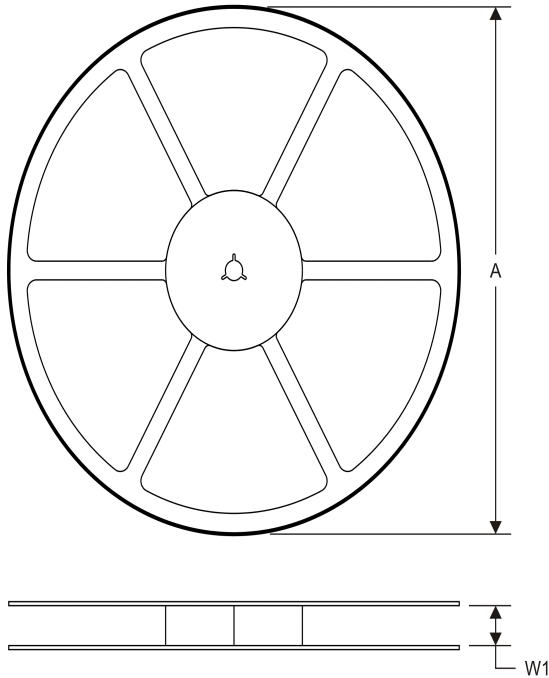
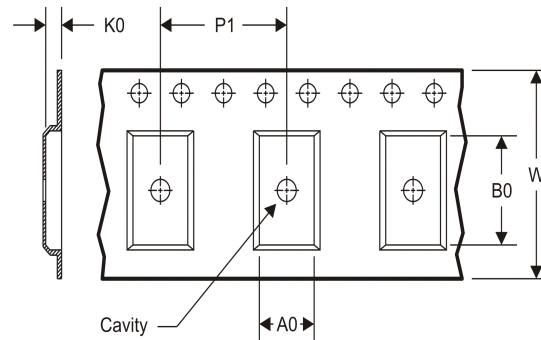
TAPE AND REEL INFORMATION
REEL DIMENSIONS

TAPE DIMENSIONS

A0	Dimension designed to accommodate the component width
B0	Dimension designed to accommodate the component length
K0	Dimension designed to accommodate the component thickness
W	Overall width of the carrier tape
P1	Pitch between successive cavity centers

TAPE AND REEL INFORMATION

*All dimensions are nominal

Device	Package Type	Package Drawing	Pins	SPQ	Reel Diameter (mm)	Reel Width W1 (mm)	A0 (mm)	B0 (mm)	K0 (mm)	P1 (mm)	W (mm)	Pin1 Quadrant
THS4531IDGKR	MSOP	DGK	8	2500	330.0	12.4	5.3	3.4	1.4	8.0	12.0	Q1
THS4531IDR	SOIC	D	8	2500	330.0	12.4	6.4	5.2	2.1	8.0	12.0	Q1
THS4531IRUNR	QFN	RUN	10	3000	180.0	8.4	2.3	2.3	1.15	4.0	8.0	Q2
THS4531IRUNT	QFN	RUN	10	250	180.0	8.4	2.3	2.3	1.15	4.0	8.0	Q2

TAPE AND REEL BOX DIMENSIONS

*All dimensions are nominal

Device	Package Type	Package Drawing	Pins	SPQ	Length (mm)	Width (mm)	Height (mm)
THS4531IDGKR	MSOP	DGK	8	2500	366.0	364.0	50.0
THS4531IDR	SOIC	D	8	2500	340.5	338.1	20.6
THS4531IRUNR	QFN	RUN	10	3000	210.0	185.0	35.0
THS4531IRUNT	QFN	RUN	10	250	210.0	185.0	35.0

DGK (S-PDSO-G8)

PLASTIC SMALL-OUTLINE PACKAGE



- NOTES:
- A. All linear dimensions are in millimeters.
 - B. This drawing is subject to change without notice.
 - C. Body length does not include mold flash, protrusions, or gate burrs. Mold flash, protrusions, or gate burrs shall not exceed 0.15 per end.
 - D. Body width does not include interlead flash. Interlead flash shall not exceed 0.50 per side.
 - E. Falls within JEDEC MO-187 variation AA, except interlead flash.

RUN (S-PWQFN-N10)

PLASTIC QUAD FLATPACK NO-LEAD

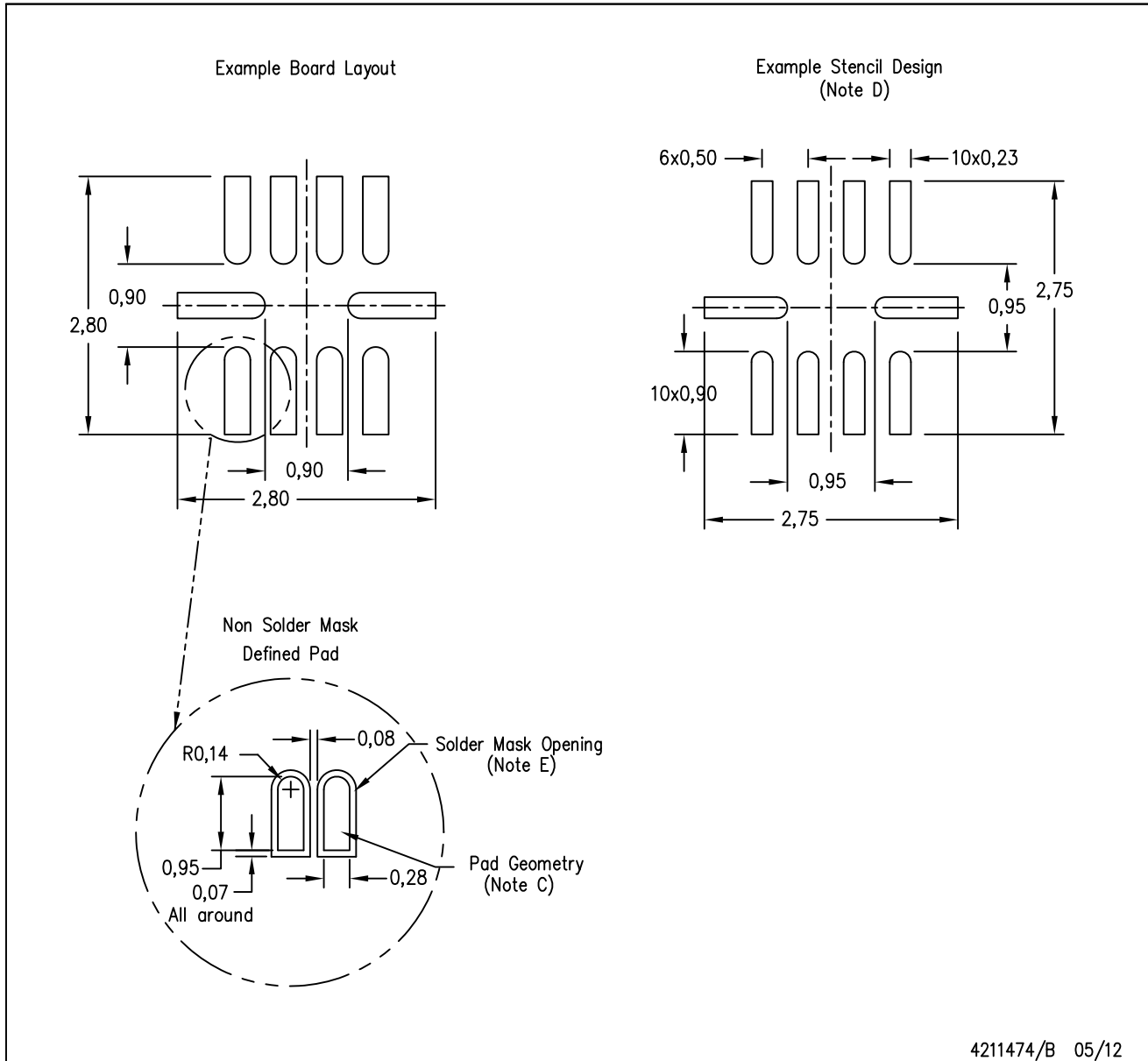

- NOTES:
- All linear dimensions are in millimeters.
 - This drawing is subject to change without notice.
 - Publication IPC-7351 is recommended for alternate designs.
 - Laser cutting apertures with trapezoidal walls and also rounding corners will offer better paste release. Customers should contact their board assembly site for stencil design recommendations. Refer to IPC 7525 for stencil design considerations.
 - Customers should contact their board fabrication site for minimum solder mask web tolerances between signal pads.

D (R-PDSO-G8)

PLASTIC SMALL OUTLINE

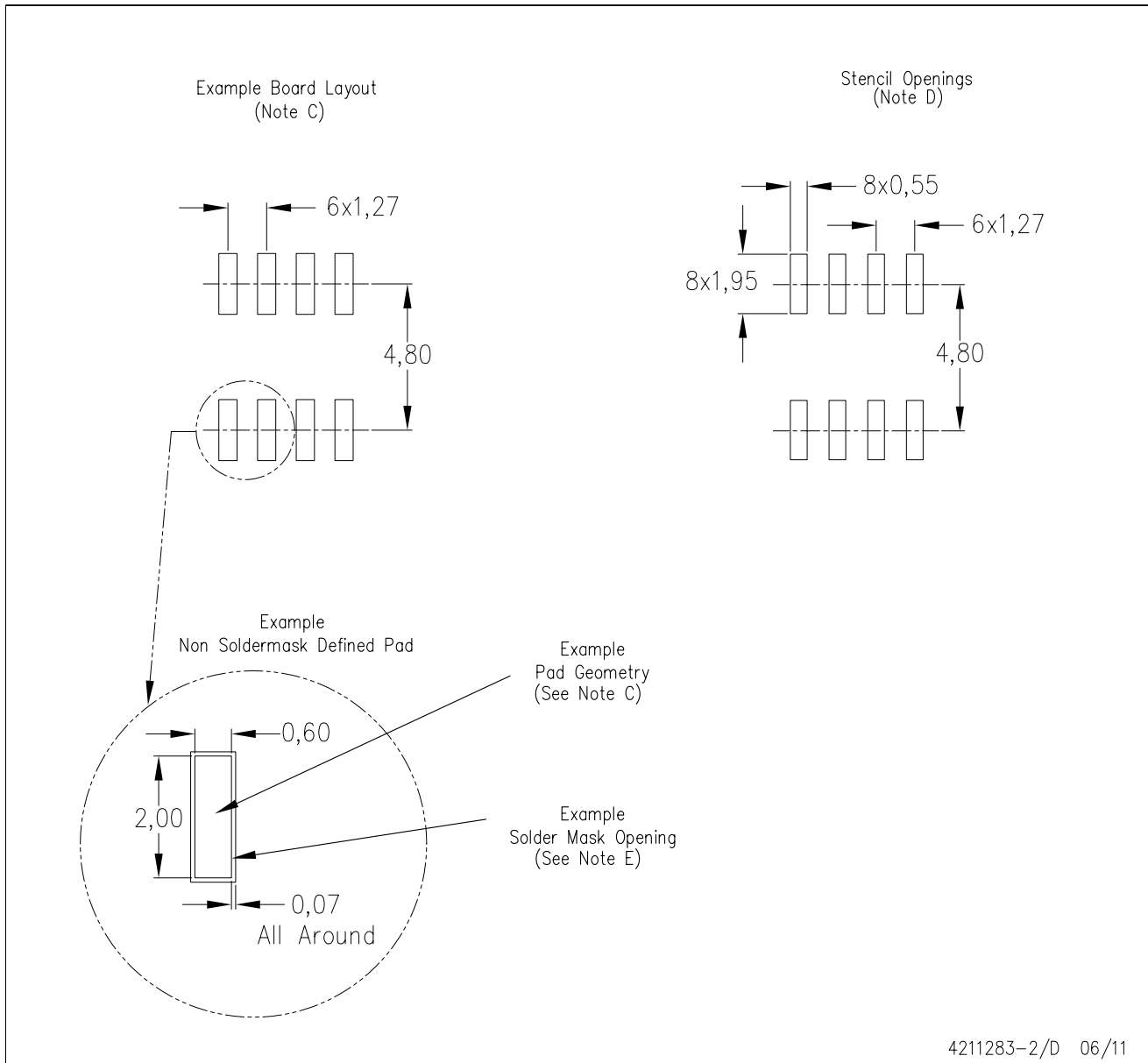

- NOTES:
- All linear dimensions are in millimeters.
 - This drawing is subject to change without notice.
 - Publication IPC-7351 is recommended for alternate designs.
 - Laser cutting apertures with trapezoidal walls and also rounding corners will offer better paste release. Customers should contact their board assembly site for stencil design recommendations. Refer to IPC-7525 for other stencil recommendations.
 - Customers should contact their board fabrication site for solder mask tolerances between and around signal pads.

IMPORTANT NOTICE

Texas Instruments Incorporated and its subsidiaries (TI) reserve the right to make corrections, modifications, enhancements, improvements, and other changes to its products and services at any time and to discontinue any product or service without notice. Customers should obtain the latest relevant information before placing orders and should verify that such information is current and complete. All products are sold subject to TI's terms and conditions of sale supplied at the time of order acknowledgment.

TI warrants performance of its hardware products to the specifications applicable at the time of sale in accordance with TI's standard warranty. Testing and other quality control techniques are used to the extent TI deems necessary to support this warranty. Except where mandated by government requirements, testing of all parameters of each product is not necessarily performed.

TI assumes no liability for applications assistance or customer product design. Customers are responsible for their products and applications using TI components. To minimize the risks associated with customer products and applications, customers should provide adequate design and operating safeguards.

TI does not warrant or represent that any license, either express or implied, is granted under any TI patent right, copyright, mask work right, or other TI intellectual property right relating to any combination, machine, or process in which TI products or services are used. Information published by TI regarding third-party products or services does not constitute a license from TI to use such products or services or a warranty or endorsement thereof. Use of such information may require a license from a third party under the patents or other intellectual property of the third party, or a license from TI under the patents or other intellectual property of TI.

Reproduction of TI information in TI data books or data sheets is permissible only if reproduction is without alteration and is accompanied by all associated warranties, conditions, limitations, and notices. Reproduction of this information with alteration is an unfair and deceptive business practice. TI is not responsible or liable for such altered documentation. Information of third parties may be subject to additional restrictions.

Resale of TI products or services with statements different from or beyond the parameters stated by TI for that product or service voids all express and any implied warranties for the associated TI product or service and is an unfair and deceptive business practice. TI is not responsible or liable for any such statements.

TI products are not authorized for use in safety-critical applications (such as life support) where a failure of the TI product would reasonably be expected to cause severe personal injury or death, unless officers of the parties have executed an agreement specifically governing such use. Buyers represent that they have all necessary expertise in the safety and regulatory ramifications of their applications, and acknowledge and agree that they are solely responsible for all legal, regulatory and safety-related requirements concerning their products and any use of TI products in such safety-critical applications, notwithstanding any applications-related information or support that may be provided by TI. Further, Buyers must fully indemnify TI and its representatives against any damages arising out of the use of TI products in such safety-critical applications.

TI products are neither designed nor intended for use in military/aerospace applications or environments unless the TI products are specifically designated by TI as military-grade or "enhanced plastic." Only products designated by TI as military-grade meet military specifications. Buyers acknowledge and agree that any such use of TI products which TI has not designated as military-grade is solely at the Buyer's risk, and that they are solely responsible for compliance with all legal and regulatory requirements in connection with such use.

TI products are neither designed nor intended for use in automotive applications or environments unless the specific TI products are designated by TI as compliant with ISO/TS 16949 requirements. Buyers acknowledge and agree that, if they use any non-designated products in automotive applications, TI will not be responsible for any failure to meet such requirements.

Following are URLs where you can obtain information on other Texas Instruments products and application solutions:

Products

Audio	www.ti.com/audio
Amplifiers	amplifier.ti.com
Data Converters	dataconverter.ti.com
DLP® Products	www.dlp.com
DSP	dsp.ti.com
Clocks and Timers	www.ti.com/clocks
Interface	interface.ti.com
Logic	logic.ti.com
Power Mgmt	power.ti.com
Microcontrollers	microcontroller.ti.com
RFID	www.ti-rfid.com
OMAP Mobile Processors	www.ti.com/omap
Wireless Connectivity	www.ti.com/wirelessconnectivity

Applications

Automotive and Transportation	www.ti.com/automotive
Communications and Telecom	www.ti.com/communications
Computers and Peripherals	www.ti.com/computers
Consumer Electronics	www.ti.com/consumer-apps
Energy and Lighting	www.ti.com/energy
Industrial	www.ti.com/industrial
Medical	www.ti.com/medical
Security	www.ti.com/security
Space, Avionics and Defense	www.ti.com/space-avionics-defense
Video and Imaging	www.ti.com/video

TI E2E Community Home Page

e2e.ti.com

Mailing Address: Texas Instruments, Post Office Box 655303, Dallas, Texas 75265
Copyright © 2012, Texas Instruments Incorporated