



## 24-BIT, 192-kHz SAMPLING, ADVANCED SEGMENT, AUDIO STEREO DIGITAL-TO-ANALOG CONVERTER

### FEATURES

- Supports Both DSD and PCM Formats
- 24-Bit Resolution
- Analog Performance:
  - Dynamic Range: 113 dB
  - THD+N: 0.001%
  - Full-Scale Output: 2.1 V rms (at Postamplifier)
- Differential Voltage Output: 3.2 V p-p
- 8× Oversampling Digital Filter:
  - Stop-Band Attenuation: –82 dB
  - Pass-Band Ripple:  $\pm 0.002$  dB
- Sampling Frequency: 10 kHz to 200 kHz
- System Clock: 128, 192, 256, 384, 512, or 768  $f_s$  With Autodetect
- Accepts 16-, 20-, and 24-Bit Audio Data
- PCM Data Formats: Standard, I<sup>2</sup>S, and Left-Justified
- DSD Format Interface Available
- Optional Interface to External Digital Filter or DSP Available
- I<sup>2</sup>C-Compatible Serial Port
- User-Programmable Mode Controls:
  - Digital Attenuation: 0 dB to –120 dB, 0.5 dB/Step
  - Digital De-Emphasis
  - Digital Filter Rolloff: Sharp or Slow
  - Soft Mute
  - Zero Flags for Each Output in PCM and DSD Formats

- Dual Supply Operation:
  - 5-V Analog, 3.3-V Digital
- 5-V Tolerant Digital Inputs
- Small 28-Lead SSOP Package

### APPLICATIONS

- A/V Receivers
- SACD Players
- DVD Players
- HDTV Receivers
- Car Audio Systems
- Digital Multitrack Recorders
- Other Applications Requiring 24-Bit Audio

### DESCRIPTION

The DSD1793 is a monolithic CMOS integrated circuit that includes stereo digital-to-analog converters and support circuitry in a small 28-lead SSOP package. The data converters use TI's advanced-segment DAC architecture to achieve excellent dynamic performance and improved tolerance to clock jitter. The DSD1793 provides balanced voltage outputs, allowing the user to optimize analog performance externally. The DSD1793 accepts the PCM and DSD audio data formats, providing easy interfacing to audio DSP and decoder chips. The DSD1793 also accepts interfaces to external digital filter devices (DF1704, DF1706, PMD200). Sampling rates up to 200 kHz are supported. A full set of user-programmable functions is accessible through an I<sup>2</sup>C-compatible serial control port.



This integrated circuit can be damaged by ESD. Texas Instruments recommends that all integrated circuits be handled with appropriate precautions. Failure to observe proper handling and installation procedures can cause damage.

ESD damage can range from subtle performance degradation to complete device failure. Precision integrated circuits may be more susceptible to damage because very small parametric changes could cause the device not to meet its published specifications.



Please be aware that an important notice concerning availability, standard warranty, and use in critical applications of Texas Instruments semiconductor products and disclaimers thereto appears at the end of this data sheet.

## ORDERING INFORMATION

PRODUCT	PACKAGE	PACKAGE CODE	OPERATION TEMPERATURE RANGE	PACKAGE MARKING	ORDERING NUMBER	TRANSPORT MEDIA
DSD1793DB	28-lead SSOP	28DB	–25°C to 85°C	DSD1793	DSD1793DB	Tube
					DSD1793DBR	Tape and reel

## ABSOLUTE MAXIMUM RATINGS

over operating free-air temperature range unless otherwise noted<sup>(1)</sup>

		DSD1791
Supply voltage	V <sub>CCF</sub> , V <sub>CCL</sub> , V <sub>CC</sub> , V <sub>CCR</sub>	–0.3 V to 6.5 V
	V <sub>DD</sub>	–0.3 V to 4 V
Supply voltage differences: V <sub>CCF</sub> , V <sub>CCL</sub> , V <sub>CC</sub> , V <sub>CCR</sub>		±0.1 V
Ground voltage differences: AGNDF, AGNDL, AGNDC, AGNDR, DGND		±0.1 V
Digital input voltage	PLRCK, PDATA, PBCK, DSDL, DSDR, DBCK, ADR0, ADR1, SCK, SCL, SDA	–0.3 V to 6.5 V
	ZEROL, ZEROR	–0.3 V to (V <sub>DD</sub> + 0.3 V) < 4 V
Analog input voltage		–0.3 V to (V <sub>CC</sub> + 0.3 V) < 6.5 V
Input current (any pins except supplies)		±10 mA
Ambient temperature under bias		–40°C to 125°C
Storage temperature		–55°C to 150°C
Junction temperature		150°C
Lead temperature (soldering)		260°C, 5 s
Package temperature (IR reflow, peak)		260°C

(1) Stresses beyond those listed under “absolute maximum ratings” may cause permanent damage to the device. These are stress ratings only, and functional operation of the device at these or any other conditions beyond those indicated under “recommended operating conditions” is not implied. Exposure to absolute-maximum-rated conditions for extended periods may affect device reliability.

## ELECTRICAL CHARACTERISTICS

all specifications at T<sub>A</sub> = 25°C, V<sub>CC</sub> = 5 V, V<sub>DD</sub> = 3.3 V, f<sub>S</sub> = 44.1 kHz, system clock = 256 f<sub>S</sub>, and 24-bit data, unless otherwise noted

PARAMETER	DSD1793DB			UNIT
	MIN	TYP	MAX	
<b>RESOLUTION</b>	24			Bits
<b>DATA FORMAT (PCM Mode)</b>				
Audio data interface format	Standard, I <sup>2</sup> S, left justified			
Audio data bit length	16-, 20-, 24-bit selectable			
Audio data format	MSB first, 2s complement			
f <sub>S</sub> Sampling frequency	10		200	kHz
System clock frequency	128, 192, 256, 384, 512, 768 f <sub>S</sub>			
<b>DATA FORMAT (DSD Mode)</b>				
Audio data interface format	DSD (direct stream digital)			
Audio data bit length	1 Bit			
f <sub>S</sub> Sampling frequency	2.8224			MHz
System clock frequency	2.8224		11.2896	MHz

**ELECTRICAL CHARACTERISTICS (Continued)**

all specifications at  $T_A = 25^\circ\text{C}$ ,  $V_{CC} = 5\text{ V}$ ,  $V_{DD} = 3.3\text{ V}$ ,  $f_S = 44.1\text{ kHz}$ , system clock =  $256 f_S$ , and 24-bit data, unless otherwise noted

PARAMETER	TEST CONDITIONS	DSD1793DB			UNIT
		MIN	TYP	MAX	
<b>DIGITAL INPUT/OUTPUT</b>					
Logic family		TTL compatible			
$V_{IH}$ $V_{IL}$	Input logic level	2			VDC
		0.8			
$I_{IH}$ $I_{IL}$	Input logic current	$V_{IN} = V_{DD}$	10		$\mu\text{A}$
		$V_{IN} = 0\text{ V}$	-10		
$V_{OH}$ $V_{OL}$	Output logic level	$I_{OH} = -2\text{ mA}$	2.4		VDC
		$I_{OL} = 2\text{ mA}$	0.4		
<b>DYNAMIC PERFORMANCE (PCM MODE) (1)</b>					
THD+N at $V_{OUT} = 0\text{ dB}$	$f_S = 44.1\text{ kHz}$	0.001%		0.002%	
	$f_S = 96\text{ kHz}$	0.0015%			
	$f_S = 192\text{ kHz}$	0.003%			
Dynamic range	EIAJ, A-weighted, $f_S = 44.1\text{ kHz}$	110	113		dB
	EIAJ, A-weighted, $f_S = 96\text{ kHz}$	113			
	EIAJ, A-weighted, $f_S = 192\text{ kHz}$	113			
Signal-to-noise ratio	EIAJ, A-weighted, $f_S = 44.1\text{ kHz}$	110	113		dB
	EIAJ, A-weighted, $f_S = 96\text{ kHz}$	113			
	EIAJ, A-weighted, $f_S = 192\text{ kHz}$	113			
Channel separation	$f_S = 44.1\text{ kHz}$	106	110		dB
	$f_S = 96\text{ kHz}$	110			
	$f_S = 192\text{ kHz}$	109			
Level linearity error	$V_{OUT} = -120\text{ dB}$	$\pm 1$			dB
<b>DYNAMIC PERFORMANCE (DSD MODE) (1) (2)</b>					
THD+N at $V_{OUT} = 0\text{ dB}$	2.1 V rms	0.001%			
Dynamic range	-60 dB, EIAJ, A-weighted	113			dB
Signal-to-noise ratio	EIAJ, A-weighted	113			dB
<b>ANALOG OUTPUT</b>					
Gain error		-8	$\pm 3$	8	% of FSR
Gain mismatch, channel-to-channel		-3	$\pm 0.5$	3	% of FSR
Bipolar zero error	At BPZ	-2	$\pm 0.5$	2	% of FSR
Differential output voltage (3)	Full scale (0 dB)	3.2			V p-p
Bipolar zero voltage (3)	At BPZ	1.4			V
Load impedance (3)	$R_1 = R_2$	1.7			k $\Omega$

(1) Dynamic performance and dc accuracy are specified at the output of the postamplifier as shown in Figure 32. Analog performance specifications are measured using the System Two™ Cascade audio measurement system by Audio Precision™ in the averaging mode. For all sampling-frequency operations, measurement bandwidth is limited with a 20-kHz AES17 filter.

(2) Analog performance in the DSD mode is specified as the DSD modulation index of 100%. This is equivalent to PCM mode performance at 44.1 kHz and  $64 f_S$ .

(3) These parameters are defined at the DSD1793 output pins. Load impedances,  $R_1$  and  $R_2$ , are input resistors of the postamplifier. They are defined as dc-coupled loads.

**ELECTRICAL CHARACTERISTICS (Continued)**all specifications at  $T_A = 25^\circ\text{C}$ ,  $V_{CC} = 5\text{ V}$ ,  $V_{DD} = 3.3\text{ V}$ ,  $f_S = 44.1\text{ kHz}$ , system clock =  $256 f_S$ , and 24-bit data, unless otherwise noted

PARAMETER	TEST CONDITIONS	DSD1793DB			UNIT	
		MIN	TYP	MAX		
<b>DIGITAL FILTER PERFORMANCE</b>						
De-emphasis error				$\pm 0.1$	dB	
<b>FILTER CHARACTERISTICS-1: SHARP ROLLOFF</b>						
Pass band	$\pm 0.002\text{ dB}$			$0.454 f_S$		
	$-3\text{ dB}$			$0.49 f_S$		
Stop band		$0.546 f_S$				
Pass-band ripple				$\pm 0.002$	dB	
Stop-band attenuation	Stop band = $0.546 f_S$		$-75$		dB	
	Stop band = $0.567 f_S$		$-82$			
Delay time			$29/f_S$		s	
<b>FILTER CHARACTERISTICS-2: SLOW ROLLOFF</b>						
Pass band	$\pm 0.04\text{ dB}$			$0.274 f_S$		
	$-3\text{ dB}$			$0.454 f_S$		
Stop band		$0.732 f_S$				
Pass-band ripple				$\pm 0.002$	dB	
Stop-band attenuation	Stop band = $0.732 f_S$		$-82$		dB	
Delay time			$29/f_S$		s	
<b>POWER SUPPLY REQUIREMENTS</b>						
$V_{DD}$	Voltage range		3	3.3	3.6	VDC
$V_{CC}$			4.5	5	5.5	VDC
$I_{DD}$	Supply current (1)	$f_S = 44.1\text{ kHz}$		6.5	8	mA
		$f_S = 96\text{ kHz}$		13.5		
		$f_S = 192\text{ kHz}$		28		
$I_{CC}$		$f_S = 44.1\text{ kHz}$		14	16	mA
		$f_S = 96\text{ kHz}$		15		
		$f_S = 192\text{ kHz}$		16		
Power dissipation (1)	$f_S = 44.1\text{ kHz}$		90	110	mW	
	$f_S = 96\text{ kHz}$		120			
	$f_S = 192\text{ kHz}$		170			
<b>TEMPERATURE RANGE</b>						
Operation temperature			$-25$		$85$	$^\circ\text{C}$
$\theta_{JA}$	Thermal resistance	28-pin SSOP		100		$^\circ\text{C/W}$

(1) Input is BPZ data.

**PIN ASSIGNMENTS**

**DSD1793  
(TOP VIEW)**

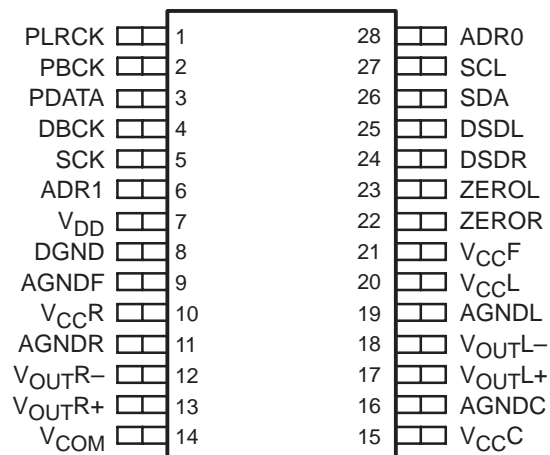

## Terminal Functions

TERMINAL		I/O	DESCRIPTIONS
NAME	PIN		
ADR0	28	I	I <sup>2</sup> C address 0 (1)
ADR1	6	I	I <sup>2</sup> C address 1 (1)
AGNDC	16	–	Analog ground (internal bias and current DAC)
AGNDF	9	–	Analog ground (DACFF)
AGNDL	19	–	Analog ground (L-channel I/V)
AGNDR	11	–	Analog ground (R-channel I/V)
DBCK	4	I	Bit clock input for DSD mode (1)
DGND	8	–	Digital ground
DSDL	25	I	L-channel audio data input for DSD mode (1)
DSDR	24	I	R-channel audio data input for DSD mode (1)
PBCK	2	I	Bit clock input for PCM mode (1)
PDATA	3	I	Serial audio data input for PCM mode (1)
PLRCK	1	I	Left and right clock (f <sub>S</sub> ) input for PCM mode (1)
SCK	5	I	System clock input (1)
SCL	27	I	I <sup>2</sup> C clock (1)
SDA	26	I/O	I <sup>2</sup> C data (2)
VCC	15	–	Analog power supply (internal bias and current DAC), 5 V
VCCF	21	–	Analog power supply (DACFF), 5 V
VCCL	20	–	Analog power supply (L-channel I/V), 5 V
VCCR	10	–	Analog power supply (R-channel I/V), 5 V
VCOM	14	–	Internal bias decoupling pin
VDD	7	–	Digital power supply, 3.3 V
VO <sub>UTL+</sub>	17	O	L-channel analog voltage output +
VO <sub>UTL-</sub>	18	O	L-channel analog voltage output –
VO <sub>UTR+</sub>	13	O	R-channel analog voltage output +
VO <sub>UTR-</sub>	12	O	R-channel analog voltage output –
ZEROL	23	O	Zero flag for L-channel
ZEROR	22	O	Zero flag for R-channel

(1) Schmitt-trigger input, 5-V tolerant

(2) Schmitt-trigger input and output. 5-V tolerant input, and open-drain, 3-state output

**FUNCTIONAL BLOCK DIAGRAM**

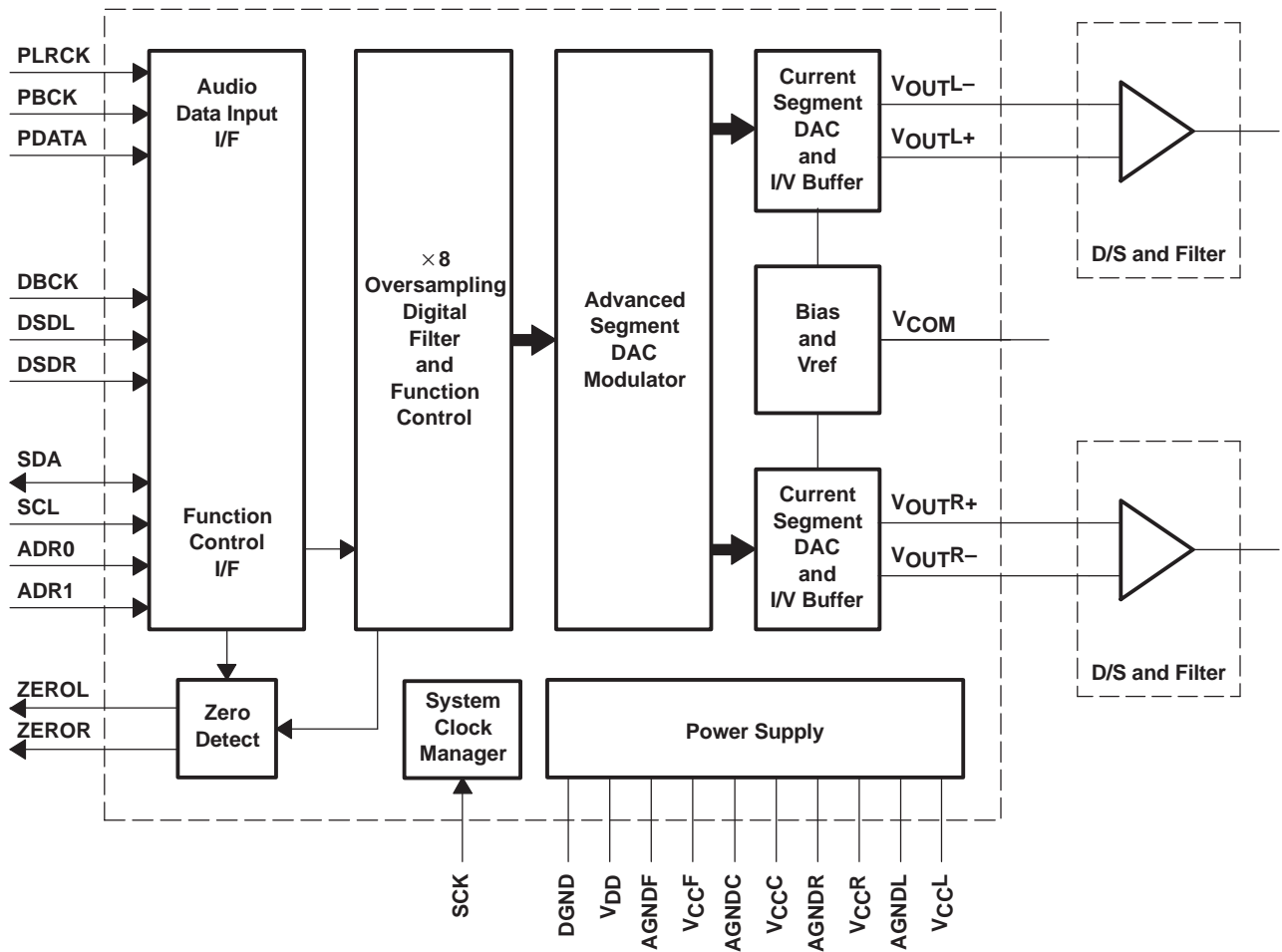

TYPICAL PERFORMANCE CURVES

DIGITAL FILTER

Digital Filter Response

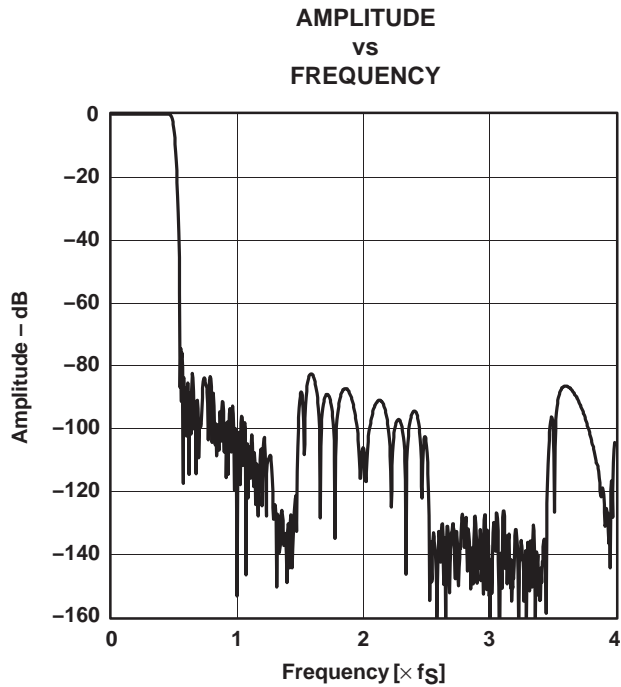

Figure 1. Frequency Response, Sharp Rolloff

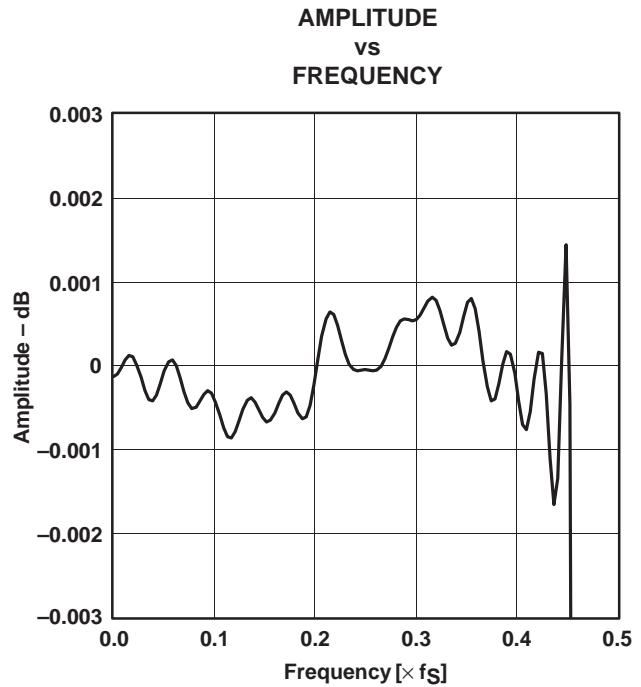

Figure 2. Pass-Band Ripple, Sharp Rolloff

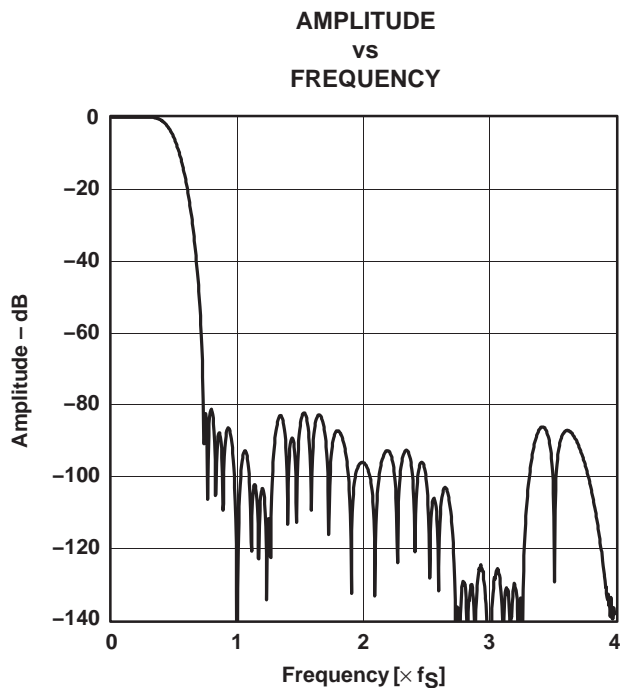

Figure 3. Frequency Response, Slow Rolloff

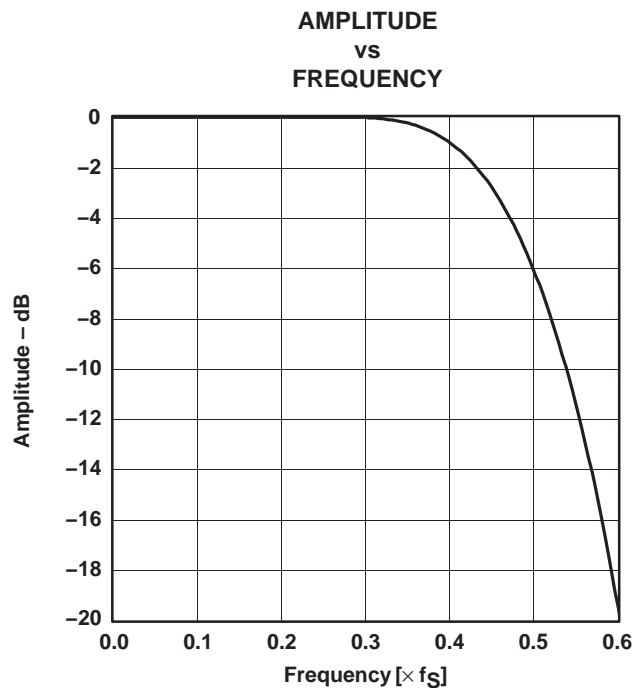

Figure 4. Transition Characteristics, Slow Rolloff



De-Emphasis Filter

DE-EMPHASIS LEVEL  
vs  
FREQUENCY

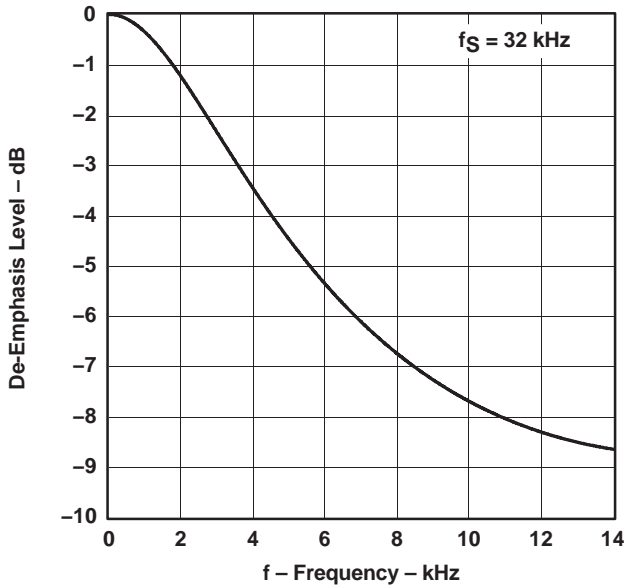

Figure 5

DE-EMPHASIS ERROR  
vs  
FREQUENCY

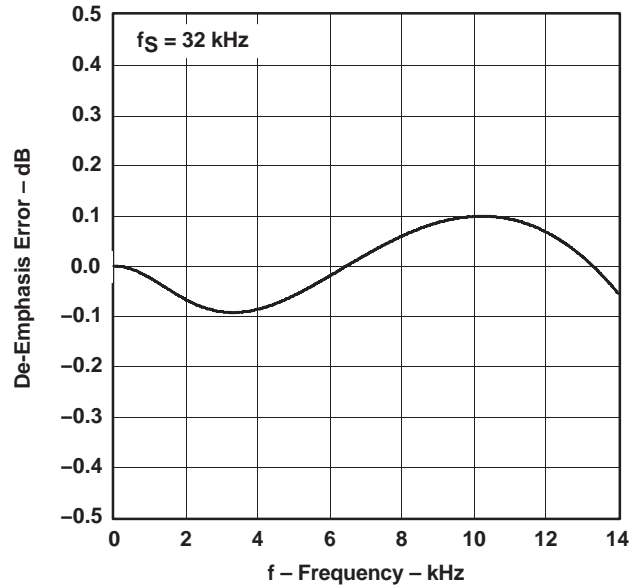

Figure 6

DE-EMPHASIS LEVEL  
vs  
FREQUENCY

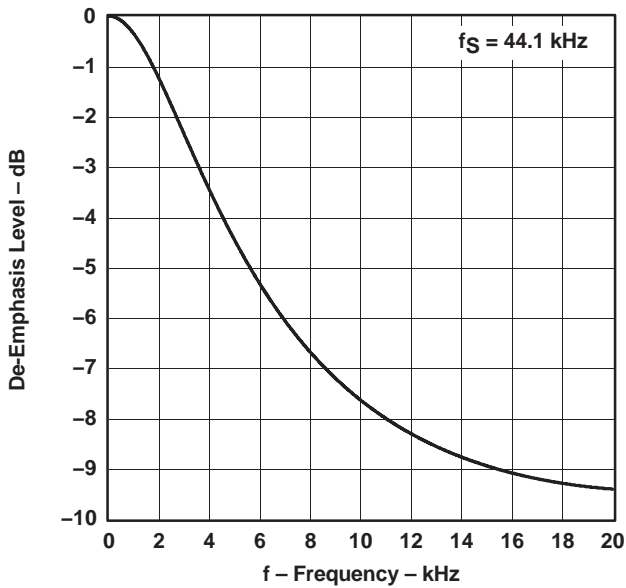

Figure 7

DE-EMPHASIS ERROR  
vs  
FREQUENCY

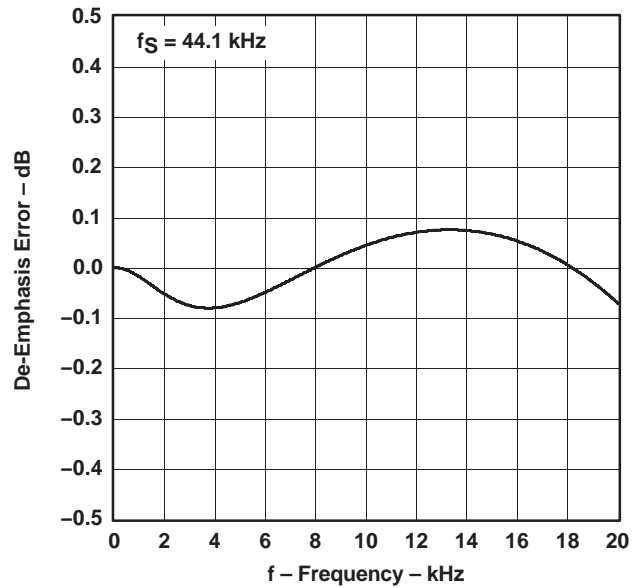
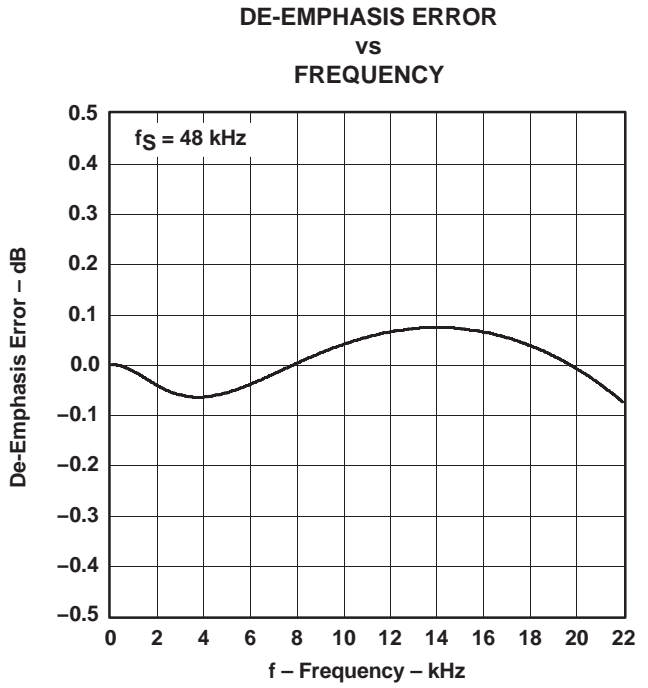
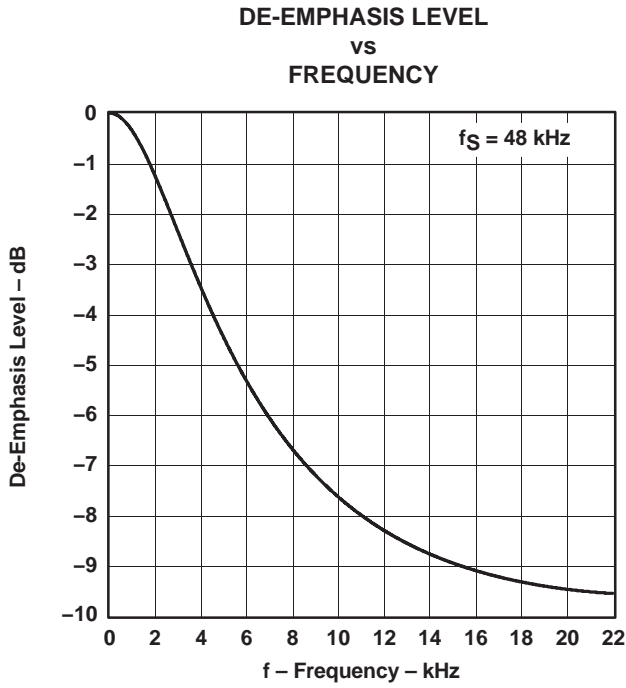

Figure 8

De-Emphasis Filter (Continued)



## ANALOG DYNAMIC PERFORMANCE

### Supply Voltage Characteristics

TOTAL HARMONIC DISTORTION + NOISE  
vs  
SUPPLY VOLTAGE

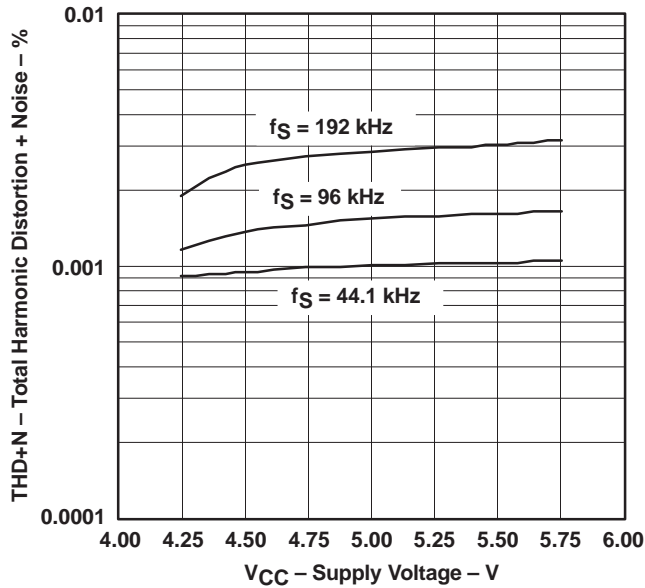

Figure 11

DYNAMIC RANGE  
vs  
SUPPLY VOLTAGE

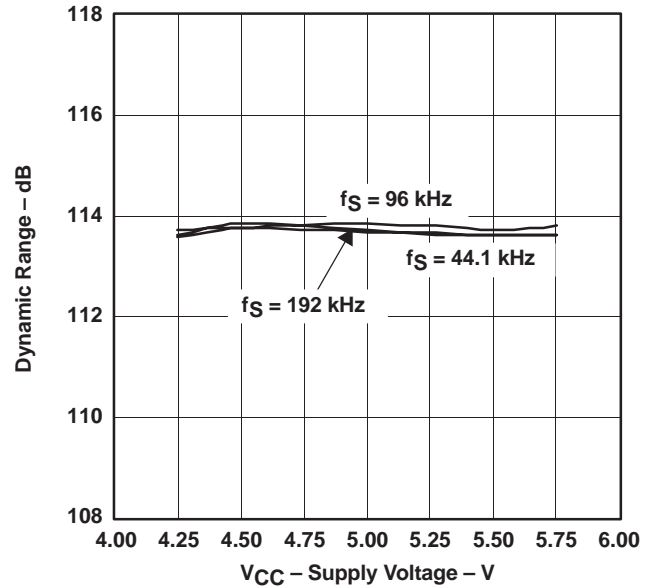

Figure 12

SIGNAL-to-NOISE RATIO  
vs  
SUPPLY VOLTAGE

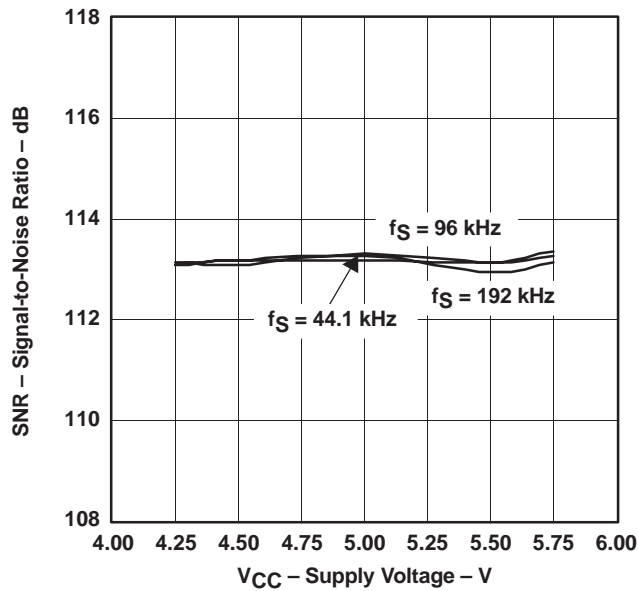

Figure 13

CHANNEL SEPARATION  
vs  
SUPPLY VOLTAGE

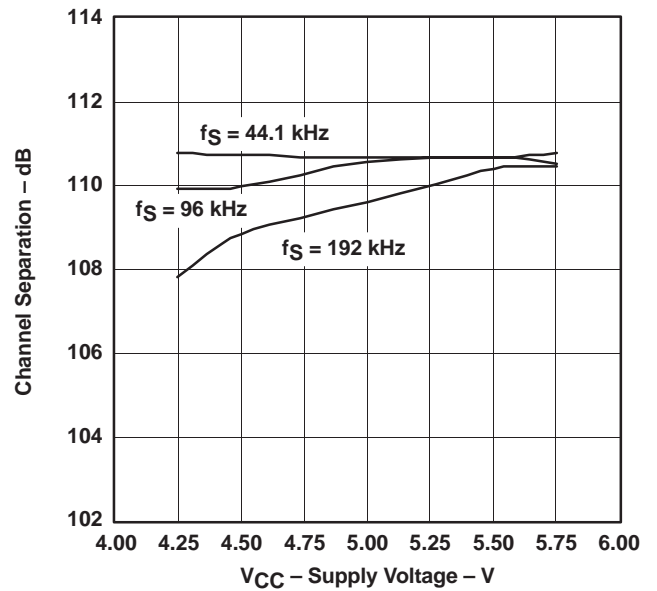

Figure 14

NOTE: PCM mode, T<sub>A</sub> = 25°C, V<sub>DD</sub> = 3.3 V.

Temperature Characteristics

TOTAL HARMONIC DISTORTION + NOISE  
VS  
FREE-AIR TEMPERATURE

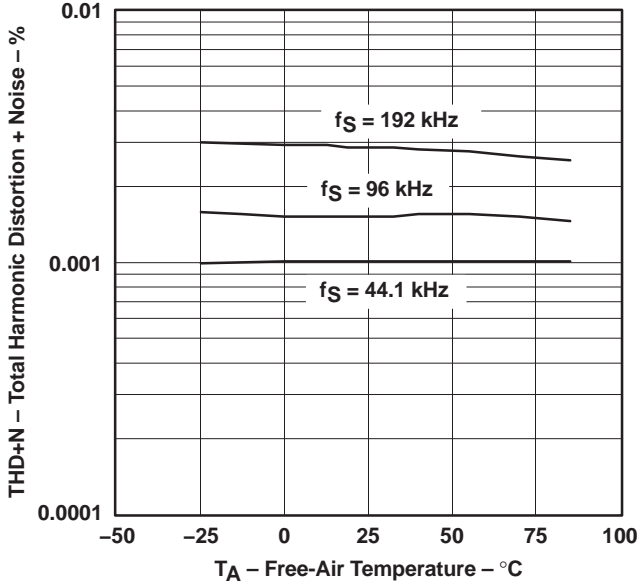

Figure 15

DYNAMIC RANGE  
VS  
FREE-AIR TEMPERATURE

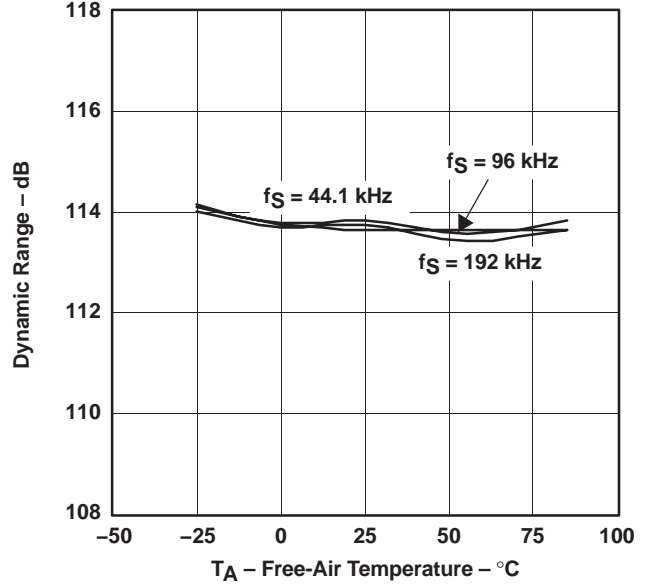

Figure 16

SIGNAL-to-NOISE RATIO  
VS  
FREE-AIR TEMPERATURE

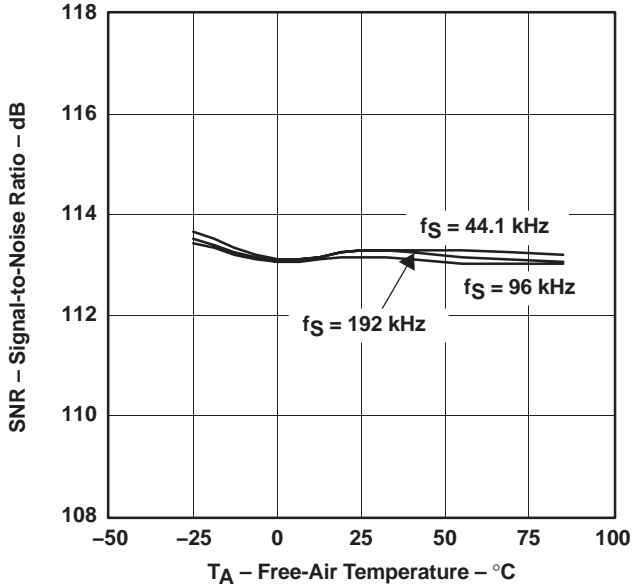

Figure 17

CHANNEL SEPARATION  
VS  
FREE-AIR TEMPERATURE

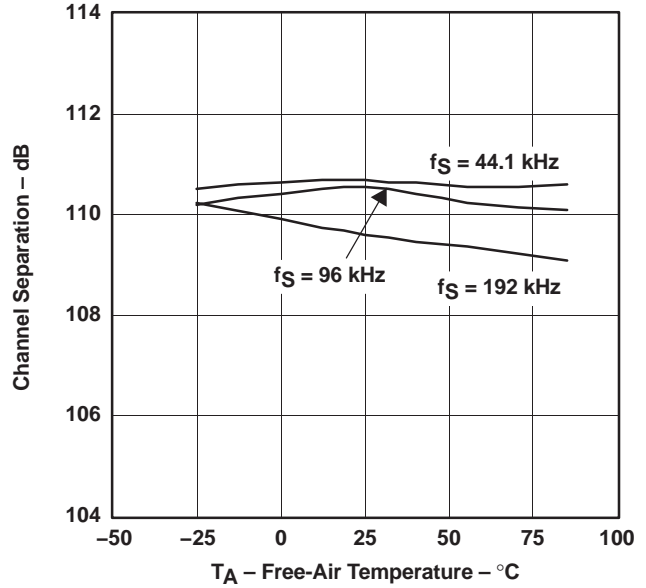
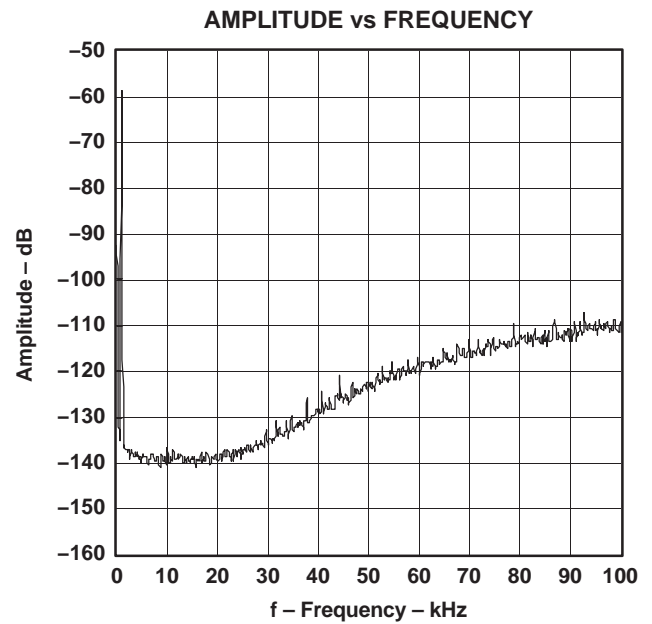
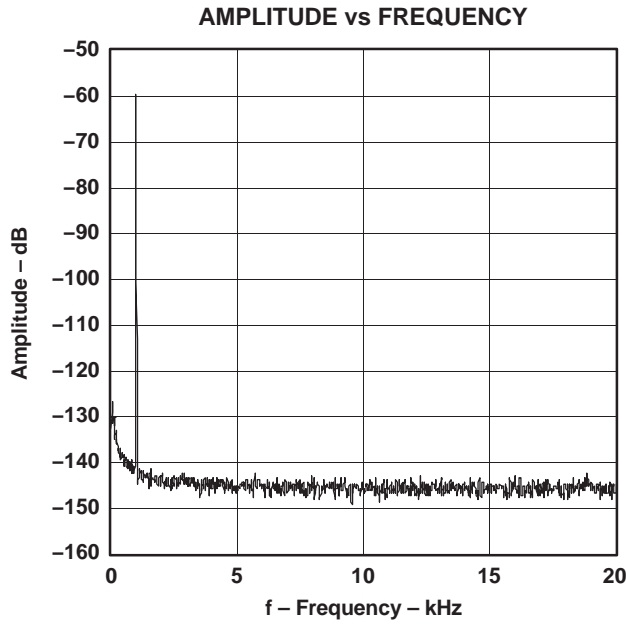

Figure 18

NOTE: PCM mode, V<sub>DD</sub> = 3.3 V, V<sub>CC</sub> = 5 V.



**Figure 19. –60-dB Output Spectrum, BW = 20 kHz    Figure 20. –60-dB Output Spectrum, BW = 100 kHz**

NOTE: PCM mode,  $f_S = 44.1$  kHz, 32768 points, 8 average,  $T_A = 25^\circ\text{C}$ ,  $V_{DD} = 3.3$  V,  $V_{CC} = 5$  V.

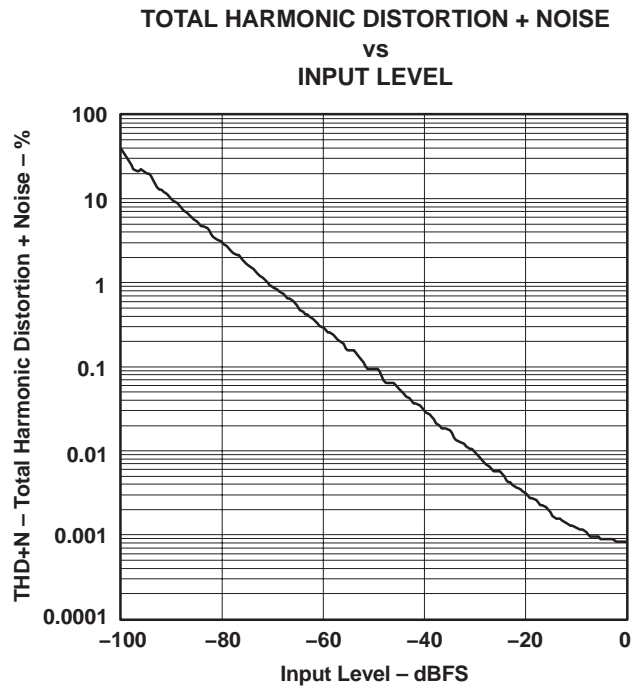

**Figure 21. THD+N vs Input Level, PCM Mode**

NOTE: PCM mode,  $f_S = 44.1$  kHz,  $T_A = 25^\circ\text{C}$ ,  $V_{DD} = 3.3$  V,  $V_{CC} = 5$  V.

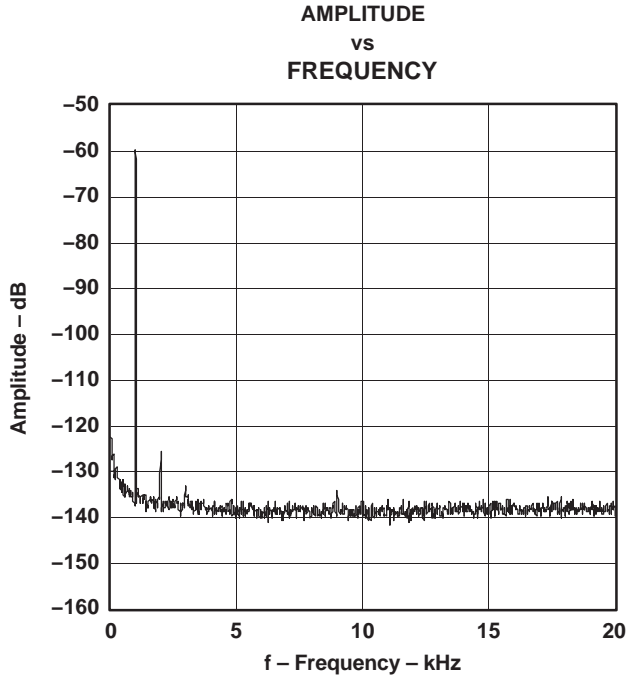

Figure 22. -60-dB Output Spectrum, DSD Mode

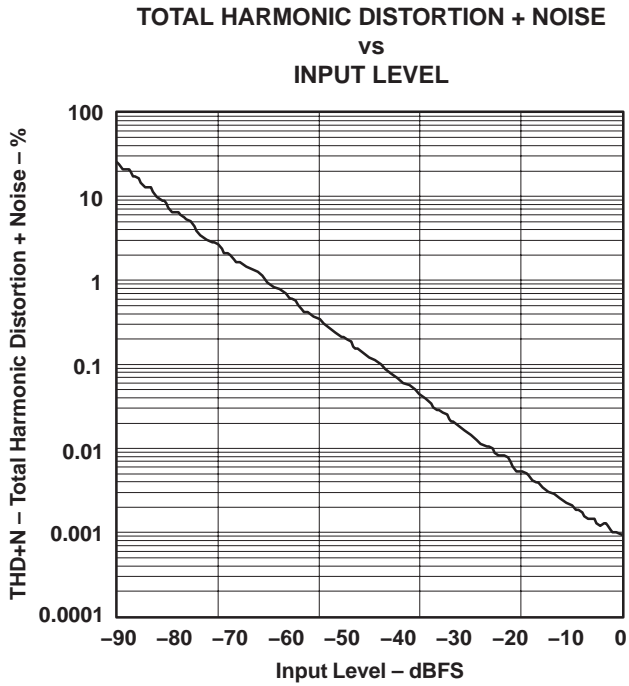

Figure 23. THD+N vs Input Level, DSD Mode

NOTE: DSD mode (FIR-2),  $T_A = 25^\circ\text{C}$ ,  $V_{DD} = 3.3\text{ V}$ ,  $V_{CC} = 5\text{ V}$ .

## SYSTEM CLOCK AND RESET FUNCTIONS

### System Clock Input

The DSD1793 requires a system clock for operating the digital interpolation filters and advanced segment DAC modulators. The system clock is applied at the SCK input (pin 5). The DSD1793 has a system clock detection circuit that automatically senses which frequency the system clock is operating. Table 1 shows examples of system clock frequencies for common audio sampling rates. If the oversampling rate of the delta-sigma modulator is selected as 128  $f_s$ , the system clock frequency is over 256  $f_s$ .

Figure 24 shows the timing requirements for the system clock input. For optimal performance, it is important to use a clock source with low phase jitter and noise. One of the Texas Instruments PLL1700 family of multiclock generators is an excellent choice for providing the DSD1793 system clock.

Table 1. System Clock Rates for Common Audio Sampling Frequencies

SAMPLING FREQUENCY	SYSTEM CLOCK FREQUENCY ( $f_{SCK}$ ) (MHz)					
	128 $f_s$	192 $f_s$	256 $f_s$	384 $f_s$	512 $f_s$	768 $f_s$
32 kHz	4.096 (1)	6.144 (1)	8.192	12.288	16.384	24.576
44.1 kHz	5.6488 (1)	8.4672	11.2896	16.9344	22.5792	33.8688
48 kHz	6.144 (1)	9.216	12.288	18.432	24.576	36.864
96 kHz	12.288	18.432	24.576	36.864	49.152 (1)	73.728 (1)
192 kHz	24.576	36.864	49.152 (1)	73.728 (1)	(2)	(2)

(1) This system clock rate is not supported in I<sup>2</sup>C fast mode.

(2) This system clock rate is not supported for the given sampling frequency.

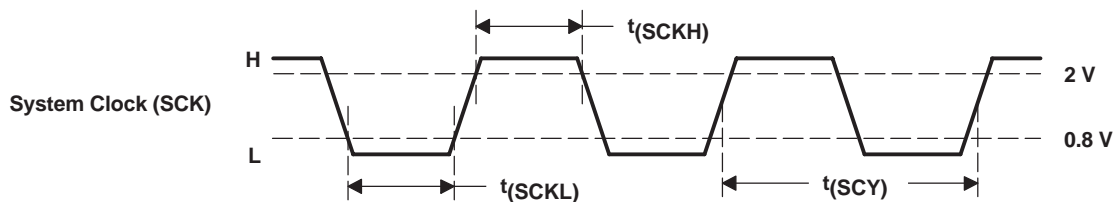

PARAMETERS		MIN	MAX	UNITS
$t(SCY)$	System clock pulse cycle time	13		ns
$t(SCKH)$	System clock pulse duration, HIGH	5		ns
$t(SCKL)$	System clock pulse duration, LOW	5		ns

Figure 24. System Clock Input Timing

### Power-On Reset Function

The DSD1793 includes a power-on reset function. Figure 25 shows the operation of this function. With  $V_{DD} > 2$  V, the power-on reset function is enabled. The initialization sequence requires 1024 system clocks from the time  $V_{DD} > 2$  V. After the initialization period, the DSD1793 is set to its default reset state, as described in the *MODE CONTROL REGISTERS* section of this data sheet.

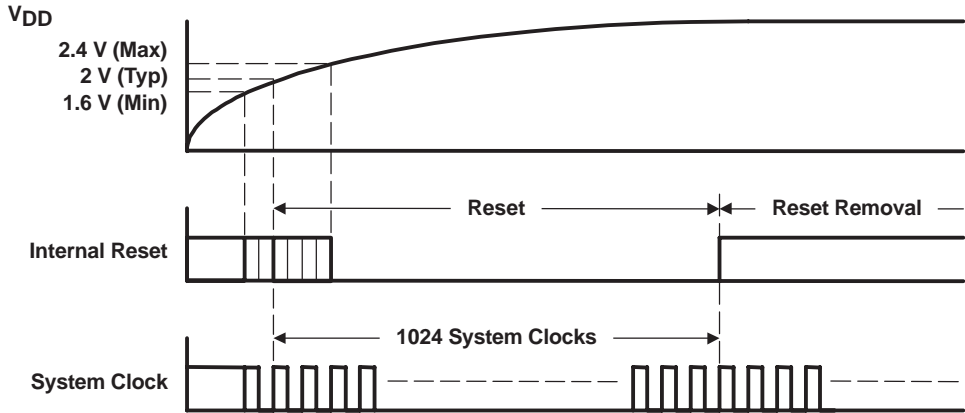

Figure 25. Power-On Reset Timing



## AUDIO DATA INTERFACE

### Audio Serial Interface

The audio interface port is a 3-wire serial port. It includes PLRCK (pin 1), PBCK (pin 2), and PDATA (pin 3). PBCK is the serial audio bit clock, and it is used to clock the serial data present on PDATA into the serial shift register of the audio interface. Serial data is clocked into the DSD1793 on the rising edge of PBCK. PLRCK is the serial audio left/right word clock.

The DSD1793 requires the synchronization of PLRCK and the system clock, but does not need a specific phase relation between PLRCK and the system clock.

If the relationship between PLRCK and the system clock changes more than  $\pm 6$  PBCK, internal operation is initialized within  $1/f_S$  and analog outputs are forced to the bipolar zero level until resynchronization between PLRCK and the system clock is completed.

### PCM Audio Data Formats and Timing

The DSD1793 supports industry-standard audio data formats, including standard right-justified, I<sup>2</sup>S, and left-justified. The data formats are shown in Figure 27. Data formats are selected using the format bits, FMT[2:0], in control register 18. The default data format is 24-bit I<sup>2</sup>S. All formats require binary 2s complement, MSB-first audio data. Figure 26 shows a detailed timing diagram for the serial audio interface.

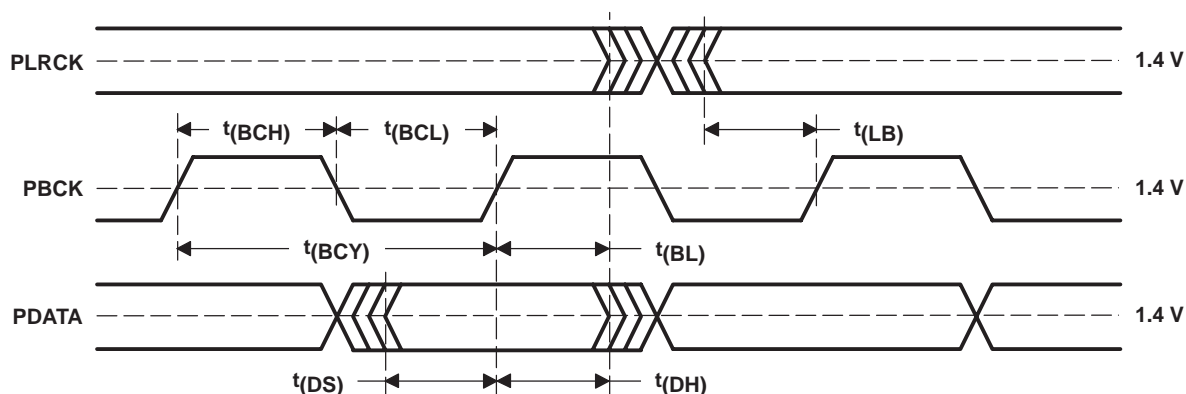

PARAMETERS		MIN	MAX	UNITS
t(BCY)	PBCK pulse cycle time	70		ns
t(BCL)	PBCK pulse duration, LOW	30		ns
t(BCH)	PBCK pulse duration, HIGH	30		ns
t(BL)	PBCK rising edge to PLRCK edge	10		ns
t(LB)	PLRCK edge to PBCK rising edge	10		ns
t(DS)	PDATA setup time	10		ns
t(DH)	PDATA hold time	10		ns
—	PLRCK clock data	50% $\pm$ 2 bit clocks		

Figure 26. Timing of Audio Interface

**(1) Standard Data Format (Right Justified) ; L-Channel = HIGH, R-Channel = LOW**

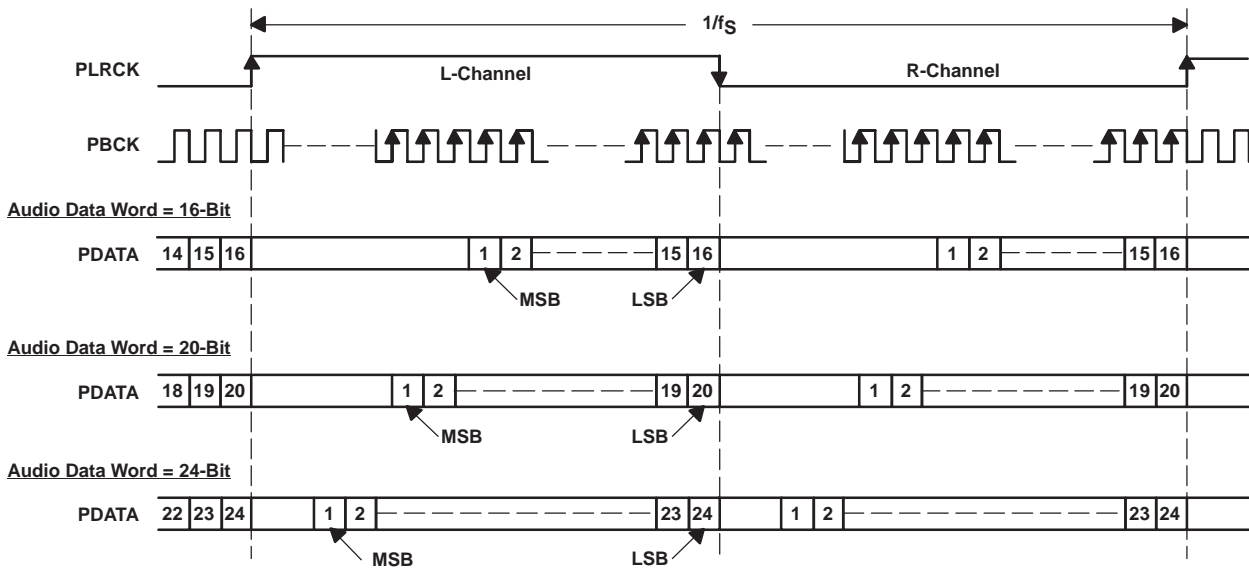

**(2) Left Justified Data Format; L-Channel = HIGH, R-Channel = LOW**

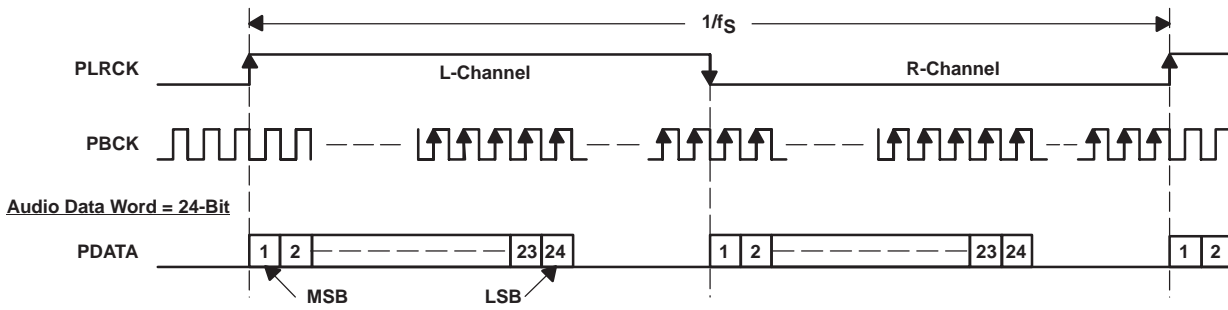

**(3) I<sup>2</sup>S Data Format; L-Channel = LOW, R-Channel = HIGH**

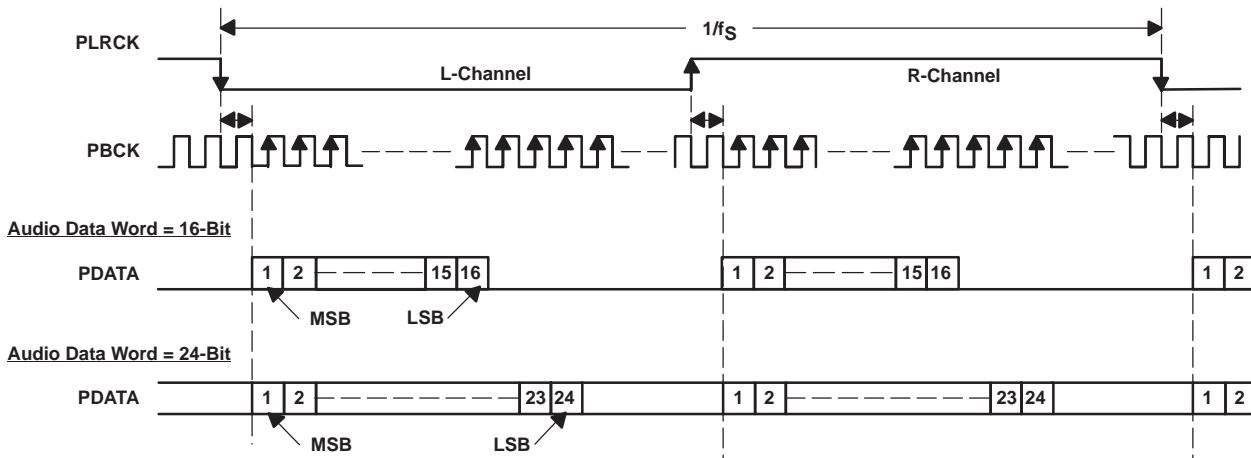

Figure 27. Audio Data Input Formats

### **External Digital Filter Interface and Timing**

The DSD1793 supports an external digital filter interface with a 3- or 4-wire synchronous serial port, which allows the use of an external digital filter. External filters include the Texas Instruments DF1704 and DF1706, the Pacific Microsonics PMD200, or a programmable digital signal processor.

In the external DF mode, PLRCK (pin 1), PBCK (pin 2) and PDATA (pin 3) are defined as WDCK, the word clock; BCK, the bit clock; and DATA, the monaural data, respectively. The external digital filter interface is selected by using the DFTH bit of control register 20, which functions to bypass the internal digital filter of the DSD1793.

When the DFMS bit of control register 19 is set, the DSD1793 can process stereo data. In this case, DSDL (pin 25) and DSDR (pin 24) are defined as L-channel data and R-channel data input, respectively.

Detailed information for the external digital filter interface mode is provided in the *APPLICATION FOR EXTERNAL DIGITAL FILTER INTERFACE* section of this data sheet.

### **Direct Stream Digital (DSD) Format Interface and Timing**

The DSD1793 supports the DSD format interface operation, which includes out-of-band noise filtering using an internal analog FIR filter. The DSD format interface consists of a 3-wire synchronous serial port, which includes DBCK (pin 4), DSDL (pin 25), and DSDR (pin 24). DBCK is the serial bit clock. DSDL and DSDR are L-channel and R-channel DSD data input, respectively. They are clocked into the DSD1793 on the rising edge of DBCK. PLRCK (pin 1) and PBCK (pin 2) must be connected to GND in the DSD mode. The DSD format (DSD mode) interface is activated by setting the DSD bit of control register 20.

Detailed information for the DSD mode is provided in the *APPLICATION FOR DSD FORMAT (DSD MODE) INTERFACE* section of this data sheet.

## FUNCTIONAL DESCRIPTIONS

### Zero Detect

The DSD1793 has a zero-detect function. When the DSD1793 detects the zero conditions as shown in Table 2, the DSD1793 sets ZEROL (pin 23) and ZEROR (pin 22) to HIGH.

**Table 2. Zero Conditions**

MODE		DETECTING CONDITION AND TIME
PCM		DATA is continuously LOW for 1024 LRCKs.
External DF mode		DATA is continuously LOW for 1024 WDCKs.
DSD	DZ0	There are an equal number of 1s and 0s in every 8 bits of DSD input data for 23 ms.
	DZ1	The input data is 1001 0110 continuously for 23 ms.

### Serial Control Interface (I<sup>2</sup>C)

The DSD1793 supports the I<sup>2</sup>C serial bus and the data transmission protocol for standard and fast mode as a slave device. This protocol is explained in I<sup>2</sup>C specification 2.0.

#### Slave Address

MSB					LSB		
1	0	0	1	1	ADR1	ADR0	R/W

The DSD1793 has 7 bits for its own slave address. The first five bits (MSBs) of the slave address are factory preset to 10011. The next two bits of the address byte are the device select bits, which can be user-defined by the ADR1 and ADR0 terminals. A maximum of four DSD1793s can be connected on the same bus at one time. Each DSD1793 responds when it receives its own slave address.

#### Packet Protocol

A master device must control packet protocol, which consists of start condition, slave address, read/write bit, data if write or acknowledge if read, and stop condition. The DSD1793 supports only slave receivers and slave transmitters.

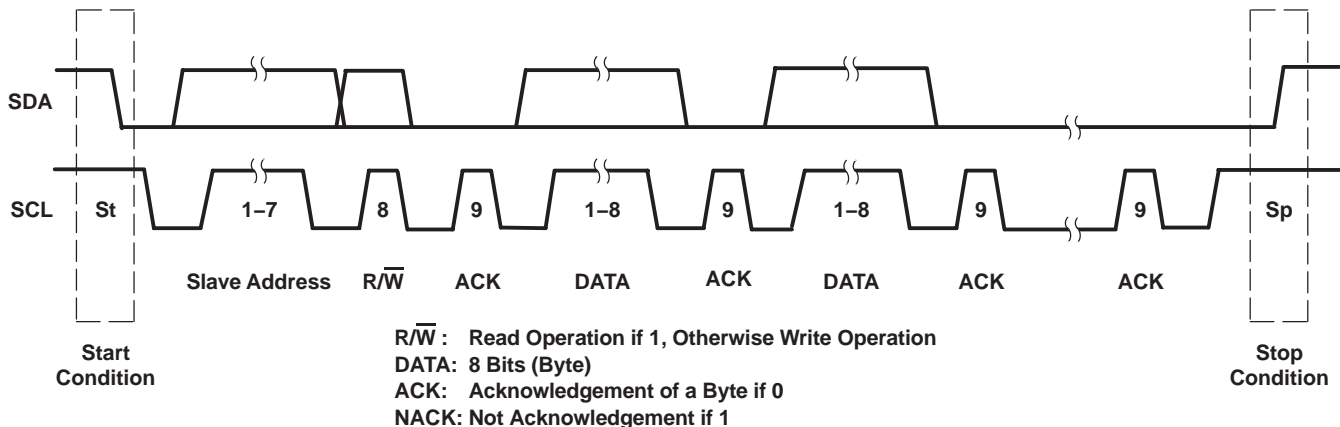

#### Write operation

Transmitter	M	M	M	S	M	S	M	S	...	S	M
Data Type	St	Slave Address	R/W	ACK	DATA	ACK	DATA	ACK	...	ACK	Sp

#### Read operation

Transmitter	M	M	M	S	S	M	S	M	...	M	M
Data Type	St	Slave Address	R	ACK	DATA	ACK	DATA	ACK	...	NACK	Sp

NOTE: M: Master Device      S: Slave Device      St: Start Condition  
 Sp: Stop Condition      W: Write      R: Read

**Figure 28. Basic I<sup>2</sup>C Framework**

## Write Register

A master can write to any DSD1793 registers using single or multiple accesses. The master sends a DSD1793 slave address with a write bit, a register address, and the data. If multiple access is required, the address is that of the starting register, followed by the data to be transferred. When the data are received properly, the index register is incremented automatically by 1. When the index register reaches 0x7F, the next value is 0x0. When undefined registers are accessed, the DSD1793 does not send an acknowledgement. Figure 29 is a diagram of the write operation.

Transmitter	M	M	M	S	M	S	M	S	M	S	...	S	M
Data Type	St	Slave Address	$\overline{W}$	ACK	Register Address	ACK	Write Data 1	ACK	Write Data 2	ACK	...	ACK	Sp

M: Master Device      S: Slave Device      St: Start Condition  
ACK: Acknowledge      Sp: Stop Condition       $\overline{W}$ : Write

**Figure 29. Write Operation**

## Read Register

A master can read the DSD1793 register. The value of the register address is stored in an indirect index register in advance. The master sends a DSD1793 slave address with a read bit after storing the register address. Then the DSD1793 transfers the data which the index register points to. When the data are transferred during a multiple access, the index register is incremented by 1 automatically. (When first going into read mode immediately following a write, the index register is not incremented. The master can read the register that was previously written.) When the index register reaches 0x7F, the next value is 0x0. The DSD1793 outputs some data when the index register is 0x10 to 0x1F, even if it is not defined in Table 4. Figure 30 is a diagram of the read operation.

Transmitter	M	M	M	S	M	S	M	M	M	S	S	M	...	M	M
Data Type	St	Slave Address	$\overline{W}$	ACK	Register Address	ACK	Sr	Slave Address	R	ACK	Data	ACK	...	NACK	Sp

M: Master Device      S: Slave Device      St: Start Condition      Sr: Repeated Start Condition  
ACK: Acknowledge      Sp: Stop Condition      NACK: Not Acknowledge       $\overline{W}$ : Write      R: Read

NOTE: The slave address after the repeat start condition must be the same as the previous slave address.

**Figure 30. Read Operation**

## Noise Suppression

The DSD1793 incorporates noise suppression using the system clock (SCK). However, there must be no more than two noise spikes in 600 ns. The noise suppression works for SCK frequencies between 8 MHz and 40 MHz in fast mode. However, it works incorrectly in the particular following conditions.

### Case 1:

1.  $t_{(SCK)} > 120 \text{ ns}$  ( $t_{(SCK)}$ : period of SCK)
2.  $t_{(HI)} + t_{(D-HD)} < t_{(SCK)} \times 5$
3. Spike noise exists on the first half of the SCL HIGH pulse.
4. Spike noise exists on the SDA HIGH pulse just before SDA goes LOW.

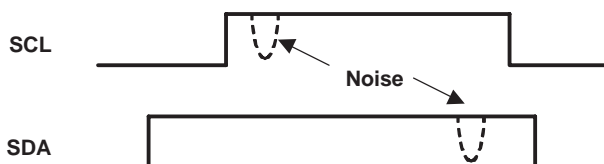

When these conditions occur at the same time, the data is recognized as LOW.

**Case 2:**

1.  $t_{(SCK)} > 120 \text{ ns}$
2.  $t_{(S-HD)}$  or  $t_{(RS-HD)} < t_{(SCK)} \times 5$
3. Spike noise exists on both SCL and SDA during the hold time.

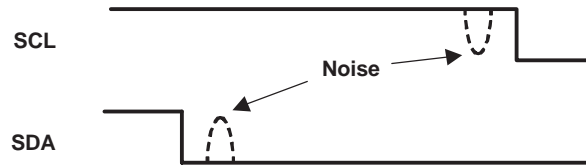

When these conditions occur at the same time, the DSD1793 fails to detect a start condition.

**Case 3:**

1.  $t_{(SCK)} < 50 \text{ ns}$
2.  $t_{(SP)} > t_{(SCK)}$
3. Spike noise exists on SCL just after SCL goes LOW.
4. Spike noise exists on SDA just before SCL goes LOW.

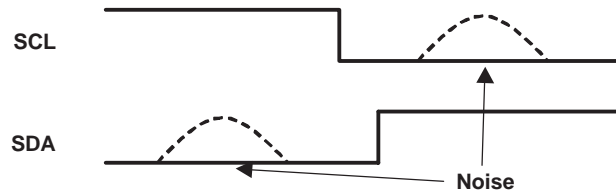

When these conditions occur at the same time, the DSD1793 erroneously detects a start or stop condition.

## TIMING DIAGRAM

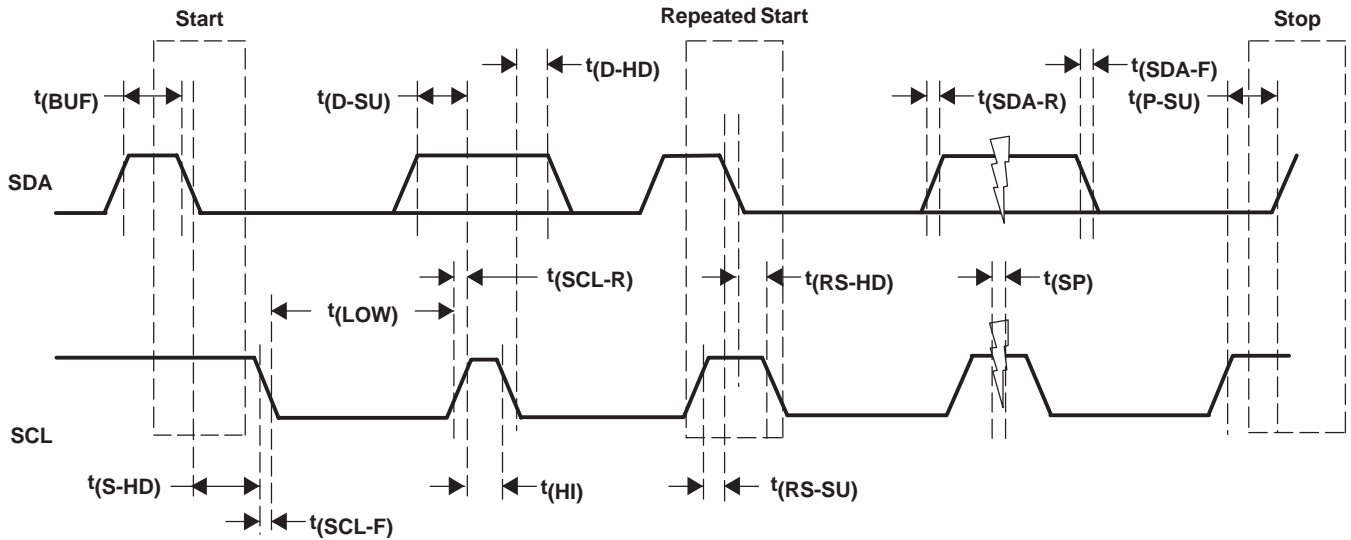

## TIMING CHARACTERISTICS

PARAMETER		CONDITIONS	MIN	MAX	UNIT
f(SCL)	SCL clock frequency	Standard		100	kHz
		Fast		400	
t(BUF)	Bus free time between stop and start conditions	Standard	4.7		μs
		Fast	1.3		
t(LOW)	Low period of the SCL clock	Standard	4.7		μs
		Fast	1.3		
t(HI)	High period of the SCL clock	Standard	4		μs
		Fast	600		
t(RS-SU)	Setup time for (repeated) start condition	Standard	4.7		μs
		Fast	600		
t(S-HD)	Hold time for (repeated) start condition	Standard	4		μs
t(RS-HD)		Fast	600		
t(D-SU)	Data setup time	Standard	250		ns
		Fast	100		
t(D-HD)	Data hold time	Standard	0	900	ns
		Fast	0	900	
t(SCL-R)	Rise time of SCL signal	Standard	20 + 0.1 C <sub>B</sub>	1000	ns
		Fast	20 + 0.1 C <sub>B</sub>	300	
t(SCL-R1)	Rise time of SCL signal after a repeated start condition and after an acknowledge bit	Standard	20 + 0.1 C <sub>B</sub>	1000	ns
		Fast	20 + 0.1 C <sub>B</sub>	300	
t(SCL-F)	Fall time of SCL signal	Standard	20 + 0.1 C <sub>B</sub>	1000	ns
		Fast	20 + 0.1 C <sub>B</sub>	300	
t(SDA-R)	Rise time of SDA signal	Standard	20 + 0.1 C <sub>B</sub>	1000	ns
		Fast	20 + 0.1 C <sub>B</sub>	300	
t(SDA-F)	Fall time of SDA signal	Standard	20 + 0.1 C <sub>B</sub>	1000	ns
		Fast	20 + 0.1 C <sub>B</sub>	300	
t(P-SU)	Setup time for stop condition	Standard	4		μs
		Fast	600		
C(B)	Capacitive load for SDA and SCL line			400	pF
t(SP)	Pulse duration of suppressed spike	Fast		50	ns
V <sub>NH</sub>	Noise margin at high level for each connected device (including hysteresis)			0.2 V <sub>DD</sub>	V

## MODE CONTROL REGISTERS

### User-Programmable Mode Controls

The DSD1793 includes a number of user-programmable functions which are accessed via mode control registers. The registers are programmed using the serial control interface, which was previously discussed in this data sheet. Table 3 lists the available mode-control functions, along with their default reset conditions and associated register index.

**Table 3. User-Programmable Function Controls**

FUNCTION	DEFAULT	REGISTER	BIT	PCM	DSD	DF BYPASS
Digital attenuation control 0 dB to –120 dB and mute, 0.5 dB step	0 dB	Register 16 Register 17	ATL[7:0] (for L-ch) ATR[7:0] (for R-ch)	yes		
Attenuation load control—Disabled, enabled	Attenuation disabled	Register 18	ATLD	yes		
Input audio data format selection 16-, 20-, 24-bit standard (right-justified) format 24-bit MSB-first left-justified format 16-/24-bit I <sup>2</sup> S format	24-bit I <sup>2</sup> S format	Register 18	FMT[2:0]	yes		yes
Sampling rate selection for de-emphasis Disabled, 44.1 kHz, 48 kHz, 32 kHz	De-emphasis disabled	Register 18	DMF[1:0]	yes	yes <sup>(1)</sup>	
De-emphasis control—Disabled, enabled	De-emphasis disabled	Register 18	DME	yes		
Soft mute control—Mute disabled, enabled	Mute disabled	Register 18	MUTE	yes		
Output phase reversal—Normal, reverse	Normal	Register 19	REV	yes	yes	yes
Attenuation speed selection $\times 1 f_S$ , $\times (1/2)f_S$ , $\times (1/4)f_S$ , $\times (1/8)f_S$	$\times 1 f_S$	Register 19	ATS[1:0]	yes		
DAC operation control—Enabled, disabled	DAC operation enabled	Register 19	OPE	yes	yes	yes
Stereo DF bypass mode select Monaural, stereo	Monaural	Register 19	DFMS			yes
Digital filter rolloff selection Sharp rolloff, slow rolloff	Sharp rolloff	Register 19	FLT	yes		
Infinite zero mute control Disabled, enabled	Disabled	Register 19	INZD	yes		yes
System reset control Reset operation, normal operation	Normal operation	Register 20	SRST	yes	yes	yes
DSD interface mode control DSD enabled, disabled	Disabled	Register 20	DSD	yes	yes	
Digital-filter bypass control DF enabled, DF bypass	DF enabled	Register 20	DFTH	yes		yes
Monaural mode selection Stereo, monaural	Stereo	Register 20	MONO	yes	yes	yes
Channel selection for monaural mode data L-channel, R-channel	L-channel	Register 20	CHSL	yes	yes	yes
Delta-sigma oversampling rate selection $\times 64 f_S$ , $\times 128 f_S$ , $\times 32 f_S$	$\times 64 f_S$	Register 20	OS[1:0]	yes	yes <sup>(2)</sup>	yes
PCM zero output enable	Enabled	Register 21	PCMZ	yes		yes
DSD zero output enable	Disabled	Register 21	DZ[1:0]		yes	
Function Available Only For Read						
Zero detection flag Not zero, zero detected	Not zero = 0 Zero detected = 1	Register 22	ZFGL (for L-ch) ZFGR (for R-ch)	yes	yes	yes

(1) When in DSD mode, DMF[1:0] is defined as DSD filter (analog FIR) performance selection.

(2) When in DSD mode, OS[1:0] is defined as DSD filter (analog FIR) operation rate selection.



## Register Map

The mode control register map is shown in Table 4. Registers 16–21 include an  $\overline{R/\overline{W}}$  bit, which determines whether a register read ( $\overline{R/\overline{W}} = 1$ ) or write ( $\overline{R/\overline{W}} = 0$ ) operation is performed. Register 22 is read-only.

**Table 4. Mode Control Register Map**

	B15	B14	B13	B12	B11	B10	B9	B8	B7	B6	B5	B4	B3	B2	B1	B0
Register 16	$\overline{R/\overline{W}}$	0	0	1	0	0	0	0	ATL7	ATL6	ATL5	ATL4	ATL3	ATL2	ATL1	ATL0
Register 17	$\overline{R/\overline{W}}$	0	0	1	0	0	0	1	ATR7	ATR6	ATR5	ATR4	ATR3	ATR2	ATR1	ATR0
Register 18	$\overline{R/\overline{W}}$	0	0	1	0	0	1	0	ATLD	FMT2	FMT1	FMT0	DMF1	DMF0	DME	MUTE
Register 19	$\overline{R/\overline{W}}$	0	0	1	0	0	1	1	REV	ATS1	ATS0	OPE	RSV	DFMS	FLT	INZD
Register 20	$\overline{R/\overline{W}}$	0	0	1	0	1	0	0	RSV	SRST	DSD	DFTH	MONO	CHSL	OS1	OS0
Register 21	$\overline{R/\overline{W}}$	0	0	1	0	1	0	1	RSV	RSV	RSV	RSV	RSV	DZ1	DZ0	PCMZ
Register 22	R	0	0	1	0	1	1	0	RSV	RSV	RSV	RSV	RSV	RSV	ZFGR	ZFGL

## Register Definitions

	B15	B14	B13	B12	B11	B10	B9	B8	B7	B6	B5	B4	B3	B2	B1	B0
Register 16	$\overline{R/\overline{W}}$	0	0	1	0	0	0	0	ATL7	ATL6	ATL5	ATL4	ATL3	ATL2	ATL1	ATL0
Register 17	$\overline{R/\overline{W}}$	0	0	1	0	0	0	1	ATR7	ATR6	ATR5	ATR4	ATR3	ATR2	ATR1	ATR0

### $\overline{R/\overline{W}}$ : Read/Write Mode Select

When  $\overline{R/\overline{W}} = 0$ , a write operation is performed.

When  $\overline{R/\overline{W}} = 1$ , a read operation is performed.

Default value: 0

### ATx[7:0]: Digital Attenuation Level Setting

These bits are available for read and write.

Default value: 1111 1111b

Each DAC output has a digital attenuator associated with it. The attenuator can be set from 0 dB to –120 dB, in 0.5-dB steps. Alternatively, the attenuator can be set to infinite attenuation (or mute).

The attenuation data for each channel can be set individually. However, the data load control (the ATLD bit of control register 18) is common to both attenuators. ATLD must be set to 1 in order to change an attenuator setting. The attenuation level can be set using the following formula:

$$\text{Attenuation level (dB)} = 0.5 \text{ dB} \cdot (\text{ATx}[7:0]_{\text{DEC}} - 255)$$

where  $\text{ATx}[7:0]_{\text{DEC}} = 0$  through 255

For  $\text{ATx}[7:0]_{\text{DEC}} = 0$  through 14, the attenuator is set to infinite attenuation. The following table shows attenuation levels for various settings:

ATx[7:0]	Decimal Value	Attenuation Level Setting
1111 1111b	255	0 dB, no attenuation (default)
1111 1110b	254	–0.5 dB
1111 1101b	253	–1.0 dB
⋮	⋮	⋮
0001 0000b	16	–119.5 dB
0000 1111b	15	–120.0 dB
0000 1110b	14	Mute
⋮	⋮	⋮
0000 0000b	0	Mute

	<b>B15</b>	<b>B14</b>	<b>B13</b>	<b>B12</b>	<b>B11</b>	<b>B10</b>	<b>B9</b>	<b>B8</b>	<b>B7</b>	<b>B6</b>	<b>B5</b>	<b>B4</b>	<b>B3</b>	<b>B2</b>	<b>B1</b>	<b>B0</b>
Register 18	R/W	0	0	1	0	0	1	0	ATLD	FMT2	FMT1	FMT0	DMF1	DMF0	DME	MUTE

**R/W: Read/Write Mode Select**

When  $R/\overline{W} = 0$ , a write operation is performed.

When  $R/\overline{W} = 1$ , a read operation is performed.

Default value: 0

**ATLD: Attenuation Load Control**

This bit is available for read and write.

Default value: 0

ATLD = 0	Attenuation control disabled (default)
ATLD = 1	Attenuation control enabled

The ATLD bit enables loading of the attenuation data contained in registers 16 and 17. When ATLD = 0, the attenuation settings remain at the previously programmed levels, ignoring new data loaded from registers 16 and 17. When ATLD = 1, attenuation data written to registers 16 and 17 is loaded normally.

**FMT[2:0]: Audio Interface Data Format**

These bits are available for read and write.

Default value: 101

FMT[2:0]	Audio Data Format Selection
000	16-bit standard format, right-justified data
001	20-bit standard format, right-justified data
010	24-bit standard format, right-justified data
011	24-bit MSB-first, left-justified format data
100	16-bit I <sup>2</sup> S-format data
101	24-bit I <sup>2</sup> S-format data (default)
110	Reserved
111	Reserved

The FMT[2:0] bits select the data format for the serial audio interface.

For the external digital filter interface mode (DFTH mode), this register is operated as shown in the *APPLICATION FOR EXTERNAL DIGITAL FILTER INTERFACE* section of this data sheet.

**DMF[1:0]: Sampling Frequency Selection for the De-Emphasis Function**

These bits are available for read and write.

Default value: 00

DMF[1:0]	De-Emphasis Sampling Frequency Selection
00	Disabled (default)
01	48 kHz
10	44.1 kHz
11	32 kHz

The DMF[1:0] bits select the sampling frequency used by the digital de-emphasis function when it is enabled by setting the DME bit. The de-emphasis curves are shown in the *TYPICAL PERFORMANCE CURVES* section of this data sheet.

For the DSD mode, analog FIR filter performance can be selected using this register. A register map and filter response plots are shown in the *APPLICATION FOR DSD FORMAT (DSD MODE) INTERFACE* section of this data sheet.

**DME: Digital De-Emphasis Control**

This bit is available for read and write.

Default value: 0

DME = 0	De-emphasis disabled (default)
DME = 1	De-emphasis enabled

The DME bit enables or disables the de-emphasis function for both channels.

**MUTE: Soft Mute Control**

This bit is available for read and write.

Default value: 0

MUTE = 0	MUTE disabled (default)
MUTE = 1	MUTE enabled

The MUTE bit enables or disables the soft mute function for both channels.

Soft mute is operated as a 256-step attenuator. The speed for each step to  $-\infty$  dB (mute) is determined by the attenuation rate selected in the ATS register.

	<b>B15</b>	<b>B14</b>	<b>B13</b>	<b>B12</b>	<b>B11</b>	<b>B10</b>	<b>B9</b>	<b>B8</b>	<b>B7</b>	<b>B6</b>	<b>B5</b>	<b>B4</b>	<b>B3</b>	<b>B2</b>	<b>B1</b>	<b>B0</b>
Register 19	R/W	0	0	1	0	0	1	1	REV	ATS1	ATS0	OPE	RSV	DFMS	FLT	INZD

**R/W: Read/Write Mode Select**

When  $R/\overline{W}$  = 0, a write operation is performed.

When  $R/\overline{W}$  = 1, a read operation is performed.

Default value: 0

**REV: Output Phase Reversal**

This bit is available for read and write.

Default value: 0

REV = 0	Normal output (default)
REV = 1	Inverted output

The REV bit inverts the output phase for both channels.

**ATS[1:0]: Attenuation Rate Select**

These bits are available for read and write.

Default value: 00

<b>ATS[1:0]</b>	<b>Attenuation Rate Selection</b>
00	Every PLRCK (default)
01	PLRCK/2
10	PLRCK/4
11	PLRCK/8

The ATS[1:0] bits select the rate at which the attenuator is decremented/incremented during level transitions.

**OPE: DAC Operation Control**

This bit is available for read and write.

Default value: 0

OPE = 0	DAC operation enabled (default)
OPE = 1	DAC operation disabled

The OPE bit enables or disables the analog output for both channels. Disabling the analog outputs forces them to the bipolar zero level (BPZ) even if digital audio data is present on the input.

**DFMS: Stereo DF Bypass Mode Select**

This bit is available for read and write.

Default value: 0

DFMS = 0	Monaural (default)
DFMS = 1	Stereo input enabled

The DFMS bit enables stereo operation in the DF bypass mode. In the DF bypass mode, when DFMS is set to 0, the pin for the input data is PDATA (pin 3) only, therefore the DSD1793 operates as a monaural DAC. When DFMS is set to 1, the DSD1793 can operate as a stereo DAC with inputs of L-channel and R-channel data on DSDL (pin 25) and DSDR (pin 24), respectively.

**FLT: Digital Filter Rolloff Control**

This bit is available for read and write.

Default value: 0

FLT = 0	Sharp rolloff (default)
FLT = 1	Slow rolloff

The FLT bit selects the digital filter rolloff characteristic. The filter responses for these selections are shown in the *TYPICAL PERFORMANCE CURVES* section of this data sheet.

**INZD: Infinite Zero Detect Mute Control**

This bit is available for read and write.

Default value: 0

INZD = 0	Infinite zero detect mute disabled (default)
INZD = 1	Infinite zero detect mute enabled

The INZD bit enables or disables the zero detect mute function. Setting INZD to 1 forces muted analog outputs to hold a bipolar zero level when the DSD1793 detects zero condition in both channels. The infinite zero detect mute function is not available in the DSD mode.

	B15	B14	B13	B12	B11	B10	B9	B8	B7	B6	B5	B4	B3	B2	B1	B0
Register 20	R/W	0	0	1	0	1	0	0	RSV	SRST	DSD	DFTH	MONO	CHSL	OS1	OS0

**R/W: Read/Write Mode Select**

When  $R/\overline{W} = 0$ , a write operation is performed.

When  $R/\overline{W} = 1$ , a read operation is performed.

Default value: 0

**SRST: System Reset Control**

This bit is available for write only.

Default value: 0

SRST = 0	Normal operation (default)
SRST = 1	System reset operation (generate one reset pulse)

The SRST bit resets the DSD1793 to the initial system condition.

**DSD: DSD Interface Mode Control**

This bit is available for read and write.

Default value: 0

DSD = 0	DSD interface mode disabled (default)
DSD = 1	DSD interface mode enabled

The DSD bit enables or disables the DSD interface mode.

**DFTH: Digital Filter Bypass (or Through Mode) Control**

This bit is available for read and write.

Default value: 0

DFTH = 0	Digital filter enabled (default)
DFTH = 1	Digital filter bypassed for the external digital filter

The DFTH bit enables or disables the external digital filter interface mode.

**MONO: Monaural Mode Selection**

This bit is available for read and write.

Default value: 0

MONO = 0	Stereo mode (default)
MONO = 1	Monaural mode

The MONO function changes the operation mode from the normal stereo mode to the monaural mode. When the monaural mode is selected, both DACs operate in a balanced mode for one channel of audio input data. Channel selection is available for L-channel or R-channel data, determined by the CHSL bit as described immediately following.

**CHSL: Channel Selection for Monaural Mode**

This bit is available for read and write.

Default value: 0

CHSL = 0	L-channel selected (default)
CHSL = 1	R-channel selected

This bit is available when MONO = 1.

The CHSL bit selects L-channel or R-channel data to be used in monaural mode.

### OS[1:0]: Delta-Sigma Oversampling Rate Selection

These bits are available for read and write.

Default value: 00

OS[1:0]	Operation Speed Select
00	64 times $f_S$ (default)
01	32 times $f_S$
10	128 times $f_S$
11	Reserved

The OS bits change the oversampling rate of delta-sigma modulation. Use of this function enables the designer to stabilize the conditions at the post low-pass filter for different sampling rates. As an application example, programming to set 128 times in 44.1-kHz operation, 64 times in 96-kHz operation, and 32 times in 192-kHz operation allows the use of only a single type (cutoff frequency) of post low-pass filter. The 128- $f_S$  oversampling rate is not available at sampling rates above 100 kHz. If the 128- $f_S$  oversampling rate is selected, a system clock of more than 256  $f_S$  is required.

In DSD mode, these bits select the speed of the bit clock for DSD data coming into the analog FIR filter.

	B15	B14	B13	B12	B11	B10	B9	B8	B7	B6	B5	B4	B3	B2	B1	B0
Register 21	R/ $\overline{W}$	0	0	1	0	1	0	1	RSV	RSV	RSV	RSV	RSV	DZ1	DZ0	PCMZ

### R/ $\overline{W}$ : Read/Write Mode Select

When R/ $\overline{W}$  = 0, a write operation is performed.

When R/ $\overline{W}$  = 1, a read operation is performed.

Default value: 0

### DZ[1:0]: DSD Zero Output Enable

These bits are available for read and write.

Default value: 00

DZ[1:0]	Zero Output Enable
00	Disabled (default)
01	Even pattern detect
1x	96 $_H$ pattern detect

The DZ bits enable or disable the output zero flags, and select the zero pattern in the DSD mode.

### PCMZ: PCM Zero Output Enable

This bit is available for read and write.

Default value: 1

PCMZ = 0	PCM zero output disabled
PCMZ = 1	PCM zero output enabled (default)

The PCMZ bit enables or disables the output zero flags in the PCM mode and the external DF mode.

	B15	B14	B13	B12	B11	B10	B9	B8	B7	B6	B5	B4	B3	B2	B1	B0
Register 22	R	0	0	1	0	1	1	0	RSV	RSV	RSV	RSV	RSV	RSV	ZFGR	ZFGL

### R: Read Mode Select

Value is always 1, specifying the readback mode.

**ZFGx: Zero-Detection Flag**

Where x = L or R, corresponding to the DAC output channel. These bits are available only for readback.

Default value: 00

ZFGx = 0	Not zero
ZFGx = 1	Zero detected

These bits show zero conditions. Their status is the same as that of the zero flags on ZEROL (pin 23) and ZEROR (pin 22). See *Zero Detect* in the *FUNCTIONAL DESCRIPTIONS* section of this data sheet.

**TYPICAL CONNECTION DIAGRAM**

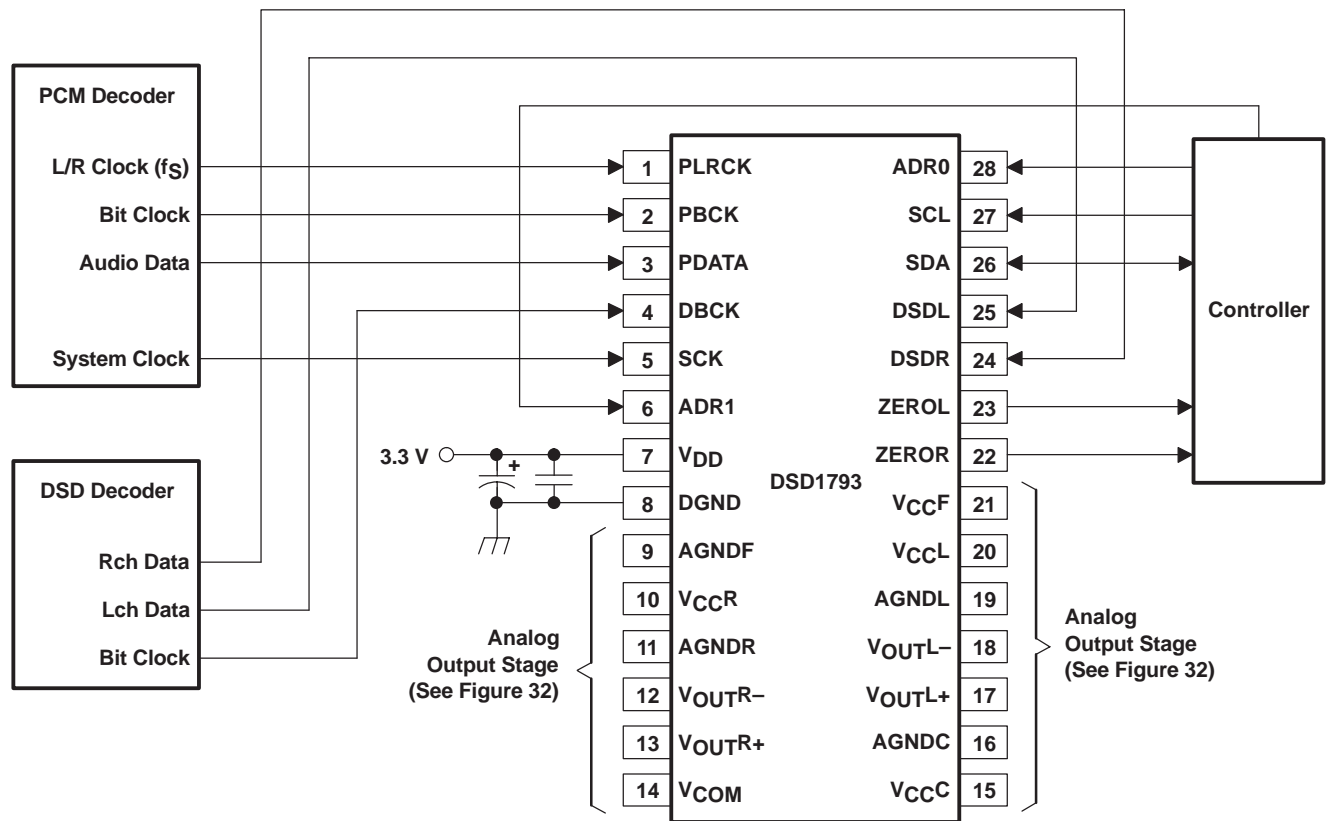

**Figure 31. Typical Application Circuit**

APPLICATION INFORMATION

ANALOG OUTPUTS

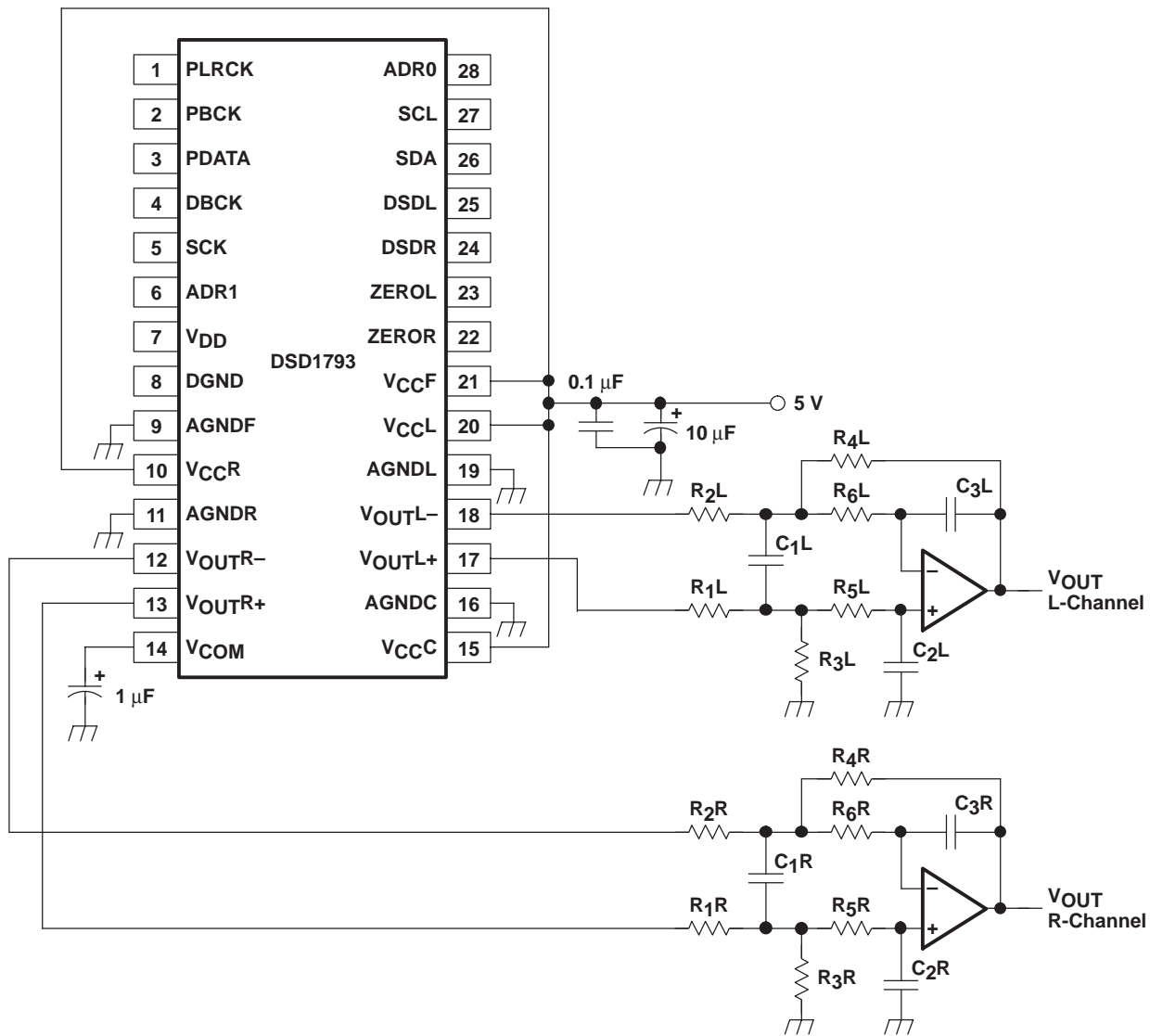

NOTE: Example R and C values for  $f_C = 77 \text{ kHz}$  –  $R_1, R_2: 1.8 \text{ k}\Omega$ ,  $R_3, R_4: 3.3 \text{ k}\Omega$ ,  $R_5, R_6: 680 \Omega$ ,  $C_1: 1800 \text{ pF}$ ,  $C_2, C_3: 560 \text{ pF}$ .

Figure 32. Typical Application for Analog Output Stage

Analog Output Level and LPF

The signal level of the DAC differential-voltage output  $\{(V_{OUTL+}) - (V_{OUTL-}), (V_{OUTR+}) - (V_{OUTR-})\}$  is 3.2 V p-p at 0 dB (full scale). The voltage output of the LPF is given by following equation:

$$V_{OUT} = 3.2 \text{ V p-p} \times (R_f/R_i)$$

Here,  $R_f$  is the feedback resistor in the LPF, and  $R_3 = R_4$  in a typical application circuit.  $R_i$  is the input resistor in the LPF, and  $R_1 = R_2$  in a typical application circuit.

Operational Amplifier for LPF

An OPA2134 or 5532 type operational amplifier is recommended for the LPF circuit to obtain the specified audio performance. Dynamic performance such as gain bandwidth, settling time, and slew rate of the operational amplifier largely determines the audio dynamic performance of the LPF section. The input noise specification of the operational amplifier should be considered to obtain a 113-dB S/N ratio.



### Analog Gain of Balanced Amplifier

The DAC voltage outputs are followed by balanced amplifier stages, which sum the differential signals for each channel, creating a single-ended voltage output. In addition, the balanced amplifiers provide a third-order low-pass filter function, which band limits the audio output signal. The cutoff frequency and gain are determined by external R and C component values. In this case, the cutoff frequency is 77 kHz with a gain of 1.83. The output voltage for each channel is 5.9 V p-p, or 2.1 V rms.

### Application for Monaural-Mode Operation

A single-channel signal from the stereo audio data input is output from both  $V_{OUTL}$  and  $V_{OUTR}$  as a differential output. The channel to be output is selected by setting the CHSL bit in register 20. The advantage of monaural operation is to provide over 115 dB of dynamic range for high-end audio applications.

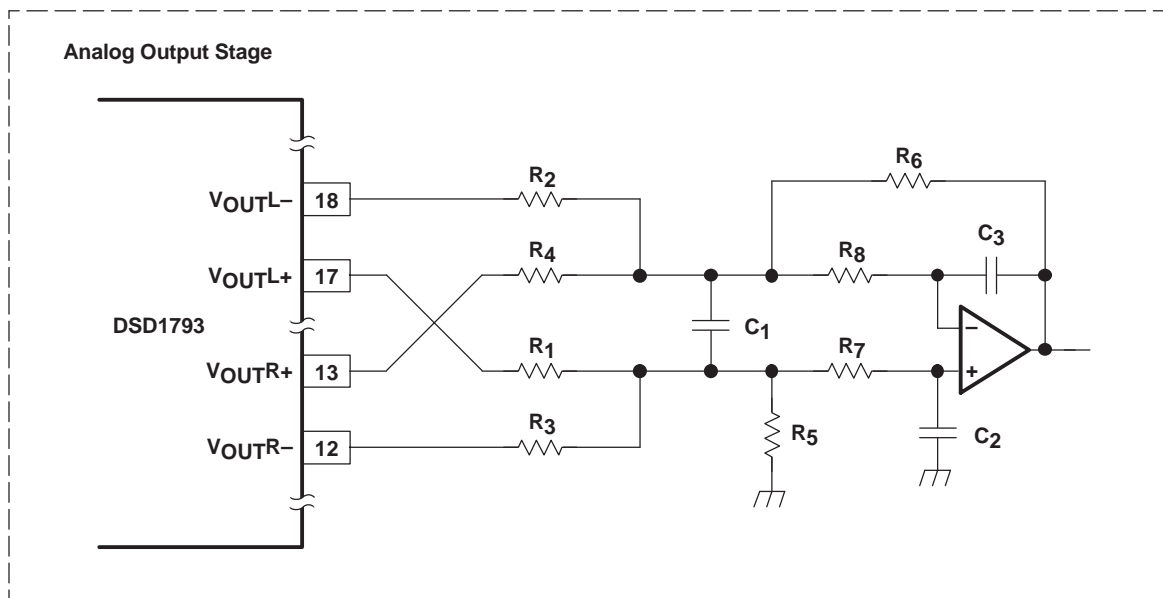
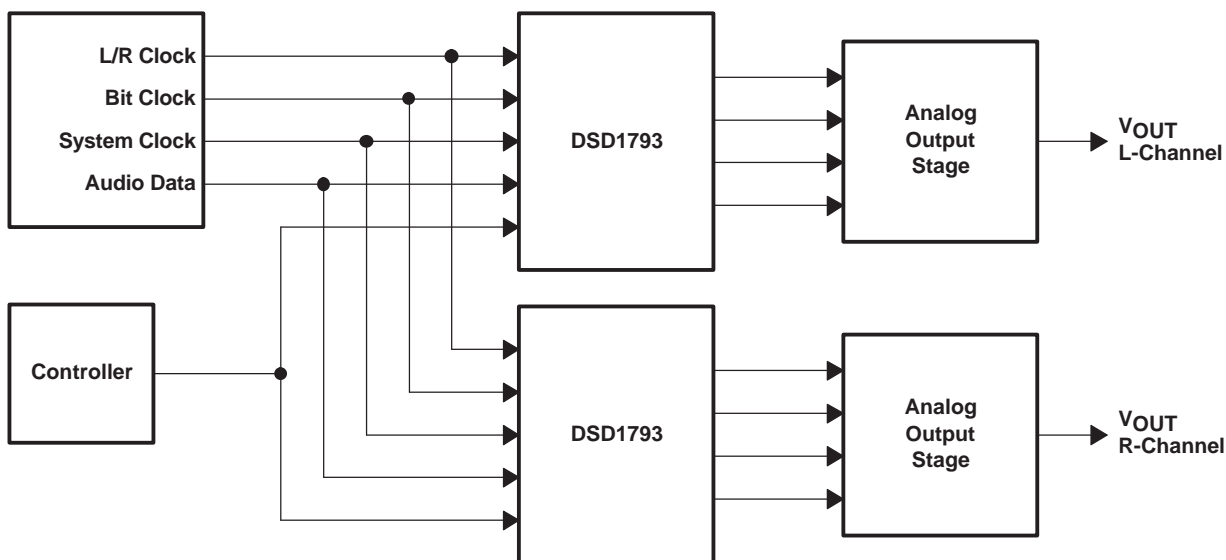

NOTE: Example R and C values for  $f_c = 77$  kHz, R1–R4: 3.6 k $\Omega$ , R5, R6: 3.3 k $\Omega$ , R7, R8: 680  $\Omega$ , C1: 1800 pF, C2, C3: 560 pF.

Figure 33. Connection Diagram for Monaural Mode Interface

**APPLICATION FOR EXTERNAL DIGITAL FILTER INTERFACE**

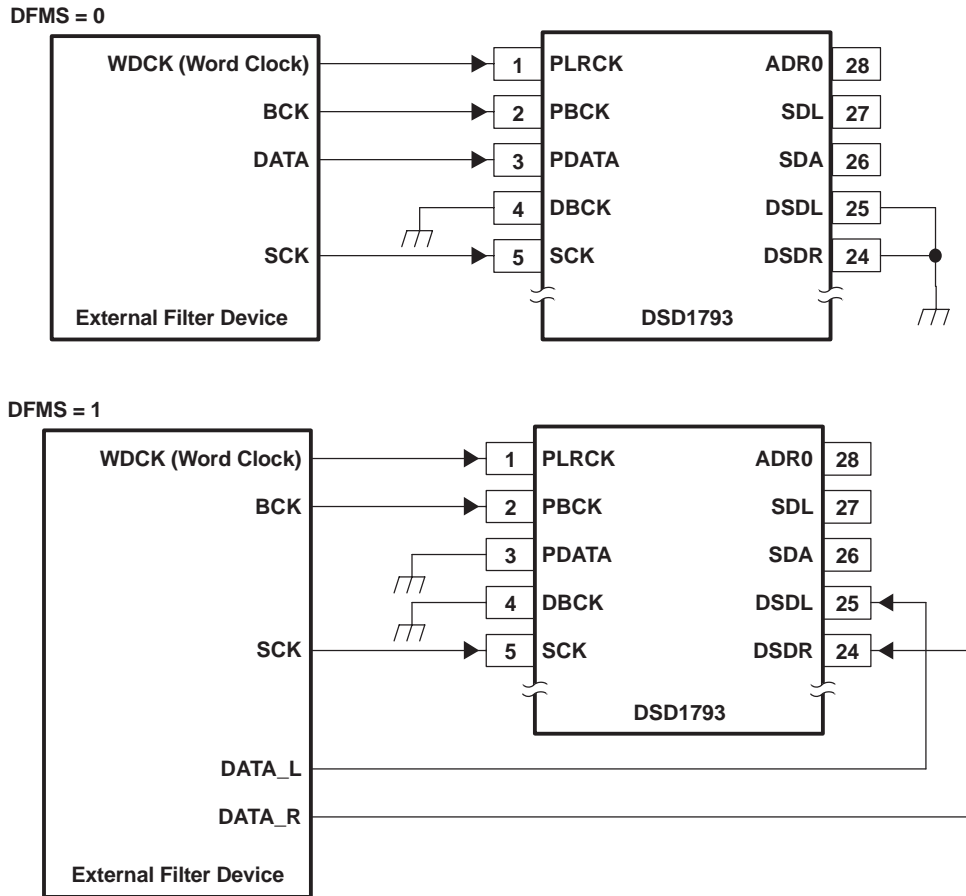

**Figure 34. Connection Diagram for External Digital Filter (Internal DF Bypass Mode) Application**

**Application for Interfacing With an External Digital Filter**

For some applications, it may be desirable to use an external digital filter to perform the interpolation function, as it can provide improved stop-band attenuation when compared to the internal digital filter of the DSD1793.

The DSD1793 supports several external digital filters, including:

- Texas Instruments DF1704 and DF1706
- Pacific Microsonics PMD200 HDCD filter/decoder IC
- Programmable digital signal processors

The external digital filter application mode is accessed by programming the following bit in the corresponding control register:

- DFTH = 1 (register 20)

The pins used to provide the serial interface for the external digital filter are shown in the connection diagram of Figure 34. The word clock (WDCK) signal must be operated at  $8\times$  or  $4\times$  the desired sampling frequency,  $f_s$ .

**Pin Assignments When Using the External Digital Filter Interface**

- PLRCK (pin 1): WDCK as word clock input
- PBCK (pin 2): BCK as bit clock for audio data
- PDATA (pin 3): DATA as monaural audio data input when the DFMS bit is not set to 1
- DSDL (pin 25): DATAL as L-channel audio data input when the DFMS bit is set to 1
- DSDR (pin 24): DATAR as R-channel audio data input when the DFMS bit is set to 1

**Audio Format**

The DSD1793 in the external digital filter interface mode supports right-justified audio formats including 16-bit, 20-bit, and 24-bit audio data, as shown in Figure 35. The audio format is selected by the FMT[2:0] bits of control register 18.

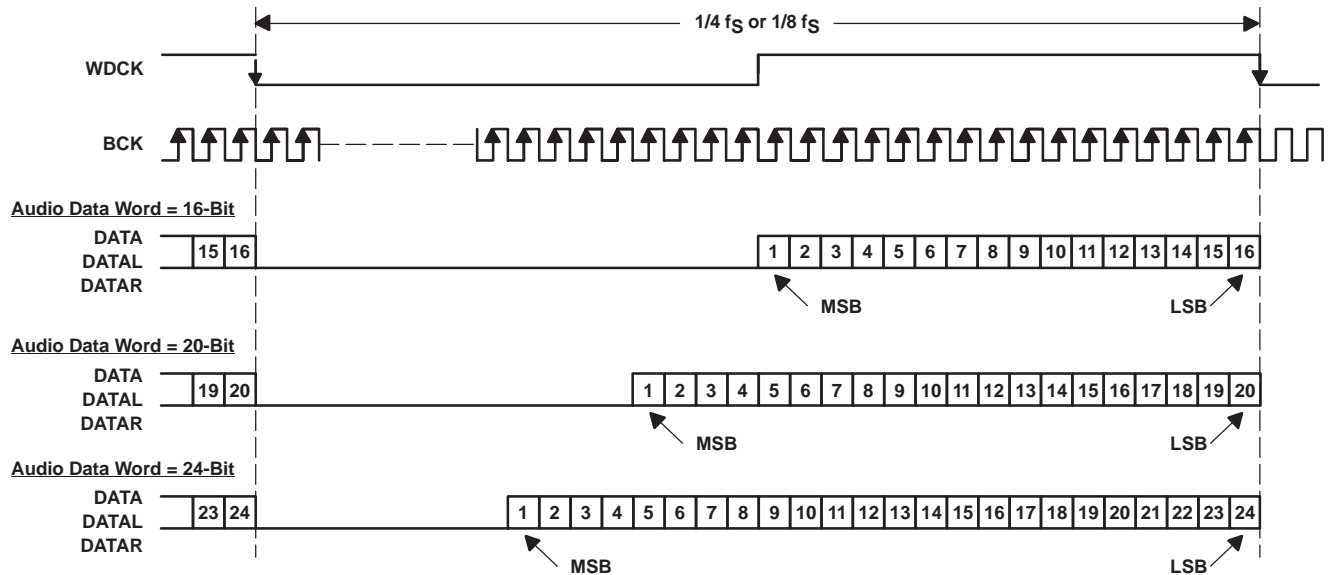

**Figure 35. Audio Data Input Format for External Digital Filter (Internal DF Bypass Mode) Application**

**System Clock (SCK) and Interface Timing**

The DSD1793 in an application using an external digital filter requires the synchronization of WDCK and the system clock. The system clock is phase-free with respect to WDCK. Interface timing among WDCK, BCK, DATA, DATAL, and DATAR is shown in Figure 36.

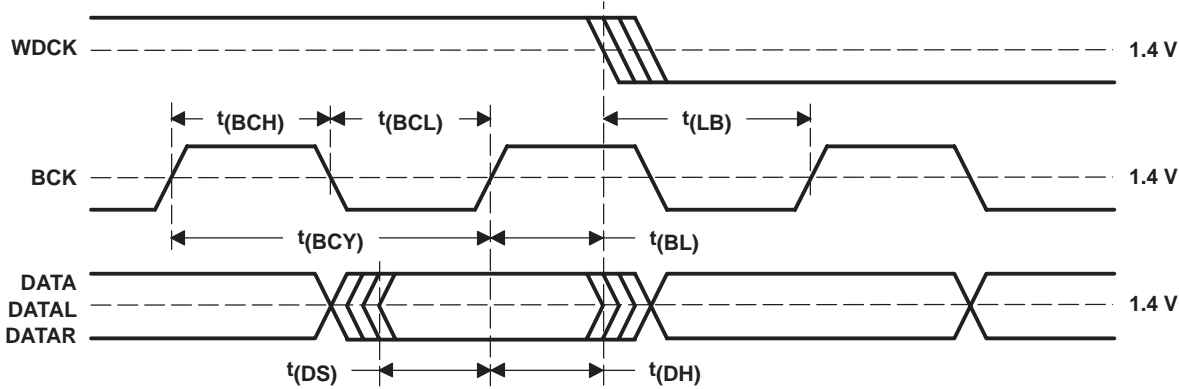

PARAMETER	MIN	MAX	UNITS
$t(BCY)$ BCK pulse cycle time	20		ns
$t(BCL)$ BCK pulse duration, LOW	7		ns
$t(BCH)$ BCK pulse duration, HIGH	7		ns
$t(BL)$ BCK rising edge to WDCK falling edge	5		ns
$t(LB)$ WDCK falling edge to BCK rising edge	5		ns
$t(DS)$ DATA, DATAL, DATAR setup time	5		ns
$t(DH)$ DATA, DATAL, DATAR hold time	5		ns

**Figure 36. Audio Interface Timing for External Digital Filter (Internal DF Bypass Mode) Application**

### Functions Available in the External Digital Filter Mode

The external digital filter mode allows access to the majority of the DSD1793 mode control functions.

The following table shows the register mapping available when the external digital filter mode is selected, along with descriptions of functions which are modified when using this mode selection.

	B15	B14	B13	B12	B11	B10	B9	B8	B7	B6	B5	B4	B3	B2	B1	B0	
<b>Register 16</b>	R/W	0	0	1	0	0	0	0	–	–	–	–	–	–	–	–	
<b>Register 17</b>	R/W	0	0	1	0	0	0	1	–	–	–	–	–	–	–	–	
<b>Register 18</b>	R/W	0	0	1	0	0	1	0	–	FMT2	FMT1	FMT0	–	–	–	–	
<b>Register 19</b>	R/W	0	0	1	0	0	1	1	REV	–	–	OPE	–	DFMS	–	INZD	
<b>Register 20</b>	R/W	0	0	1	0	1	0	0	–	SRST	0	1	MONO	CHSL	OS1	OS0	
<b>Register 21</b>	R/W	0	0	1	0	1	0	1	–	–	–	–	–	–	–	PCMZ	
<b>Register 22</b>	R	0	0	1	0	1	1	0	–	–	–	–	–	–	–	ZFGR	ZFGL

NOTE: –: Function is disabled. No operation even if data bit is set

### FMT[2:0]: Audio Data Format Selection

Default value: 000

FMT[2:0]	Audio Data Format Select
000	16-bit right-justified format (default)
001	20-bit right-justified format
010	24-bit right-justified format
Other	N/A

### OS[1:0]: Delta-Sigma Modulator Oversampling Rate Selection

Default value: 00

OS[1:0]	Operation Speed Select
00	8 times WDCK (default)
01	4 times WDCK
10	16 times WDCK
11	Reserved

The effective oversampling rate is determined by the oversampling performed by both the external digital filter and the delta-sigma modulator. For example, if the external digital filter is 8× oversampling, and the user selects OS[1:0] = 00, then the delta-sigma modulator oversamples by 8×, resulting in an effective oversampling rate of 64×. The 16× WDCK oversampling rate is not available above a 100-kHz sampling rate. If the oversampling rate selected is 16× WDCK, the system clock frequency must be over 256 f<sub>S</sub>.

## APPLICATION FOR DSD FORMAT (DSD MODE) INTERFACE

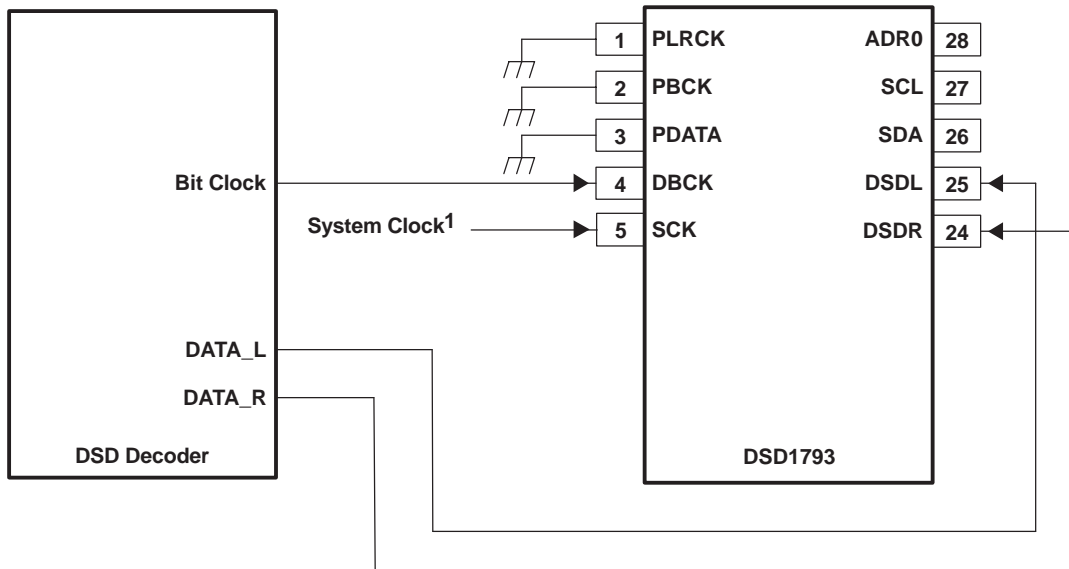

(1) The system clock is necessary for the initialization sequence and the I<sup>2</sup>C interface operation.

**Figure 37. Connection Diagram in DSD Mode**

### Feature

This mode is used for interfacing directly to a DSD decoder, which is found in Super Audio CD™ (SACD) applications. The DSD mode is accessed by programming the following bit in the corresponding control register:

- DSD = 1 (register 20)

The DSD mode provides a low-pass filtering function. The filtering is provided using an analog FIR filter structure. Four FIR responses are available, and are selected via DMF[1:0] of control register 18.

### Pin Assignment When Using the DSD Format Interface

- DSDL (pin 25): L-channel DSD data input
- DSDR (pin 24): R-channel DSD data input
- DBCK (pin 4): Bit clock (BCK) for DSD data

### Requirements for Bit Clock and System Clock

The bit clock (DBCK) for DSD mode is required at pin 4 of the DSD1793. The frequency of the bit clock can be N times the sampling frequency. Generally, N is 64 in DSD applications.

The interface timing between the bit clock and DSDL, DSDR is required to meet the setup and hold time specifications shown in Figure 39.

The system clock is necessary for the initialization sequence and the I<sup>2</sup>C interface operation.

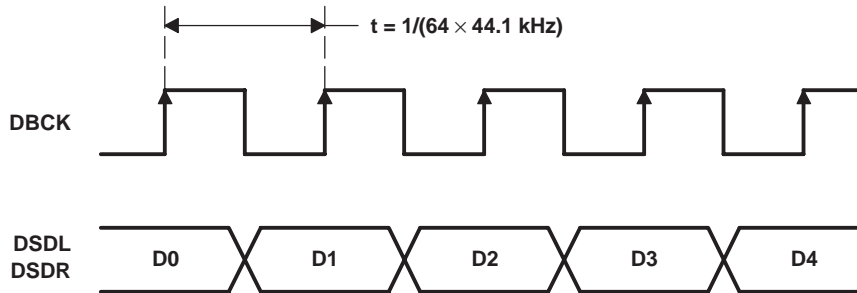
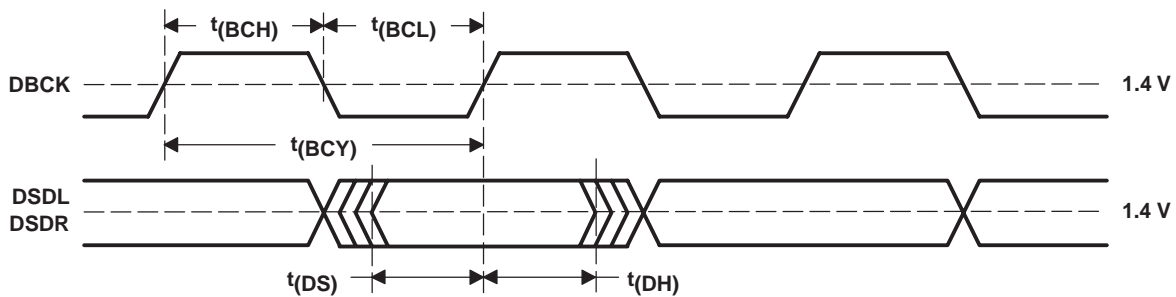

Figure 38. Normal Data Output Form From DSD Decoder



PARAMETER	MIN	MAX	UNITS
t(BCY) DBCK pulse cycle time	85 <sup>(1)</sup>		ns
t(BCH) DBCK high-level time	30		ns
t(BCL) DBCK low-level time	30		ns
t(DS) DSDL, DSDR setup time	10		ns
t(DH) DSDL, DSDR hold time	10		ns

(1) 2.8224 MHz × 4. (2.8224 MHz = 64 × 44.1 kHz. This value is specified as a sampling rate of DSD.)

Figure 39. Timing for DSD Audio Interface

**ANALOG FIR FILTER PERFORMANCE IN DSD MODE**

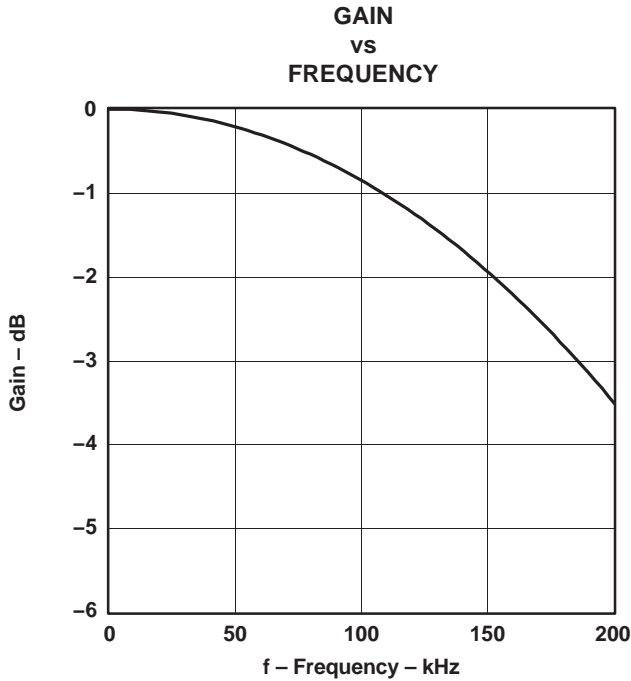

**Figure 40. DSD Filter-1, Low BW**

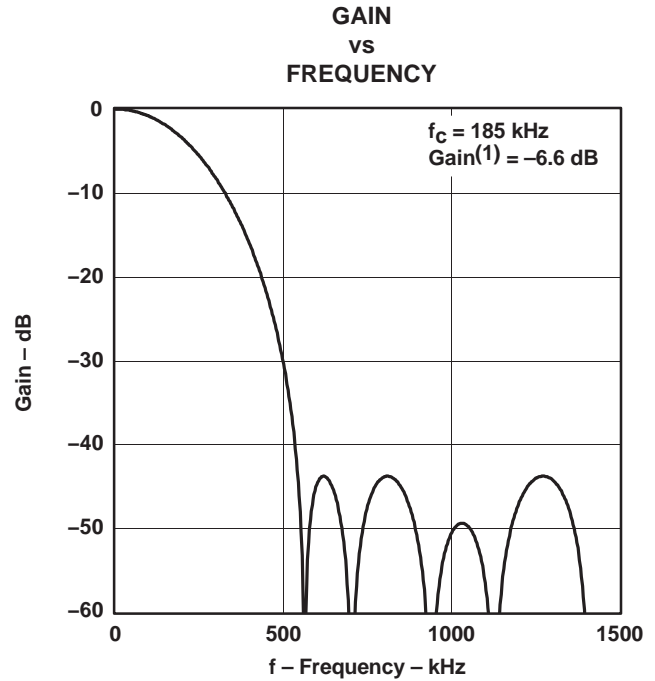

**Figure 41. DSD Filter-1, High BW**

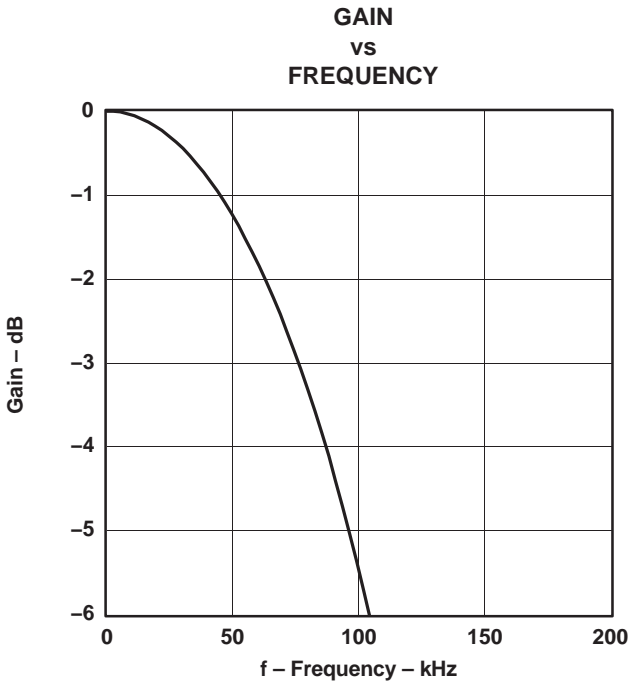

**Figure 42. DSD Filter-2, Low BW**

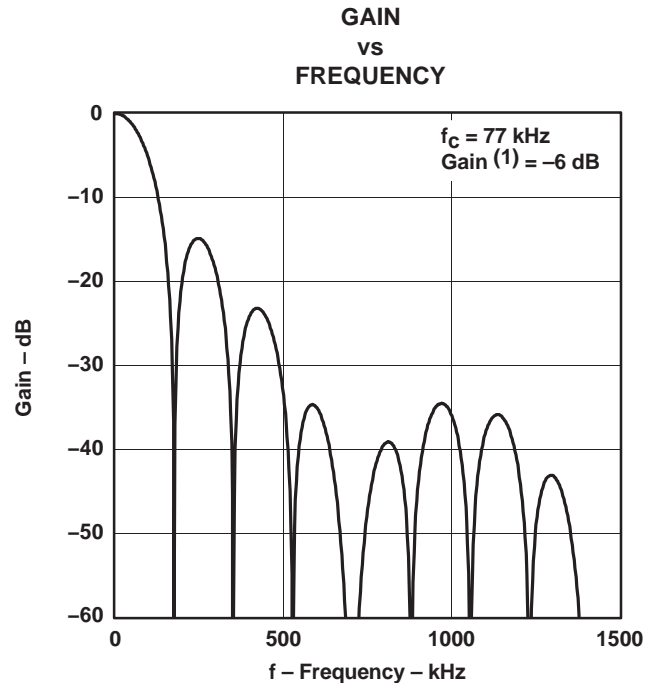
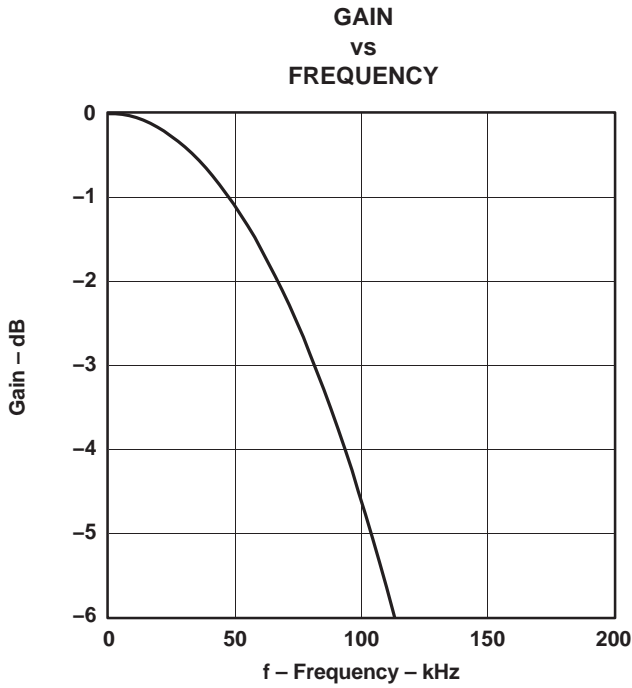

**Figure 43. DSD Filter-2, High BW**

(1) This gain is in comparison to PCM 0 dB, when the DSD input signal efficiency is 50%.



**ANALOG FIR FILTER PERFORMANCE IN DSD MODE (CONTINUED)**



**Figure 44. DSD Filter-3, Low BW**

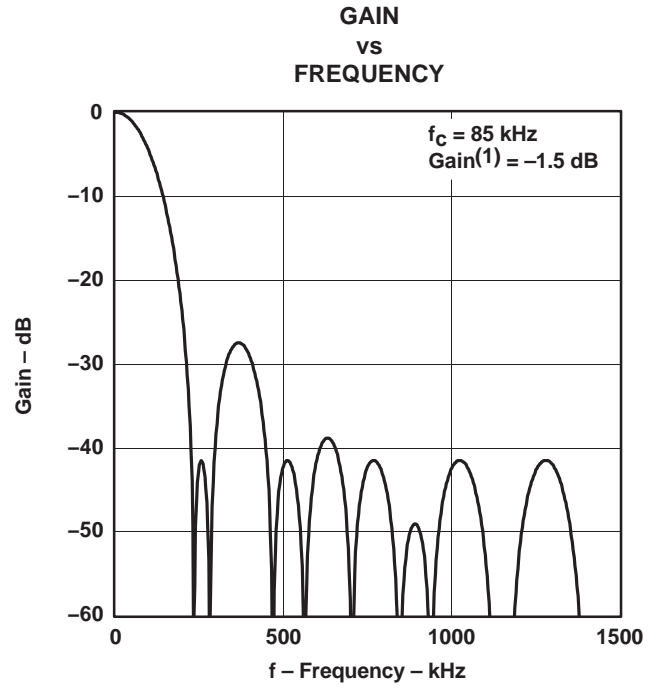

**Figure 45. DSD Filter-3, High BW**

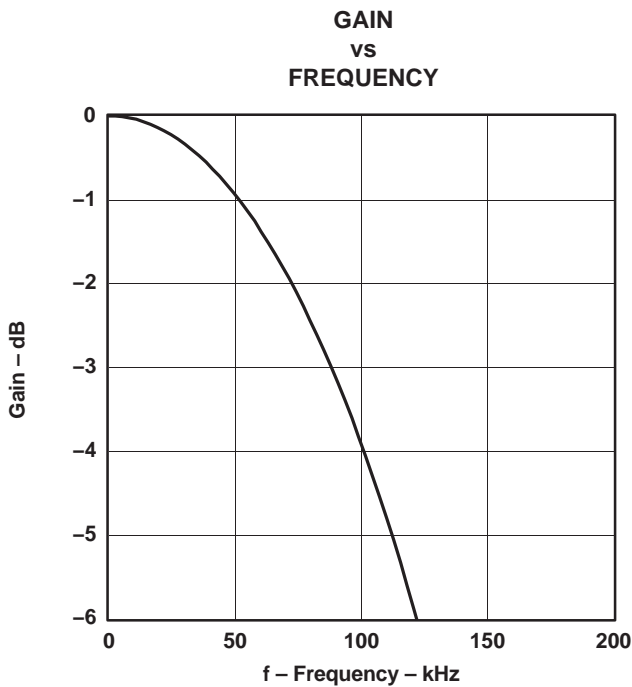

**Figure 46. DSD Filter-4, Low BW**

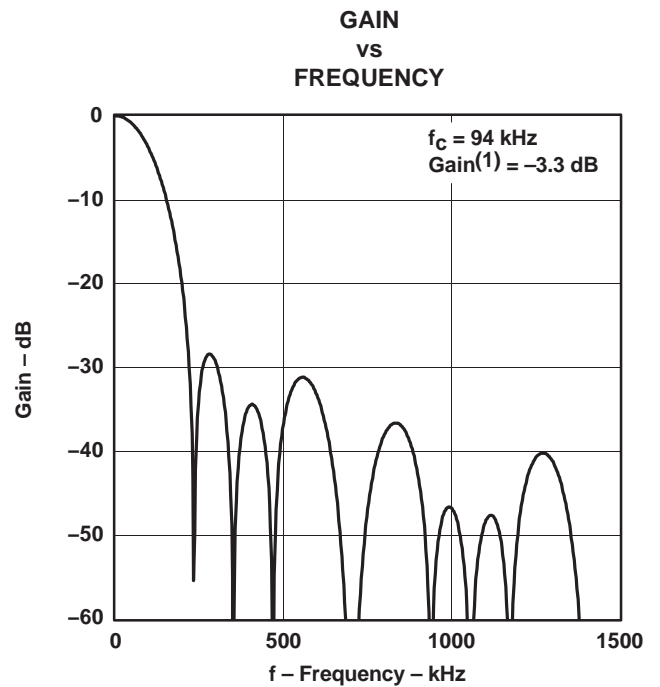

**Figure 47. DSD Filter-4, High BW**

(1) This gain is in comparison to PCM 0 dB, when the DSD input signal efficiency is 50%.

## DSD MODE CONFIGURATION AND FUNCTION CONTROLS

### Configuration for the DSD Interface Mode

DSD = 1 (Register 20, B5)

	B15	B14	B13	B12	B11	B10	B9	B8	B7	B6	B5	B4	B3	B2	B1	B0
Register 16	R $\overline{W}$	0	0	1	0	0	0	0	–	–	–	–	–	–	–	–
Register 17	R $\overline{W}$	0	0	1	0	0	0	1	–	–	–	–	–	–	–	–
Register 18	R $\overline{W}$	0	0	1	0	0	1	0	–	–	–	–	DMF1	DMF0	–	–
Register 19	R $\overline{W}$	0	0	1	0	0	1	1	REV	–	–	OPE	–	–	–	–
Register 20	R $\overline{W}$	0	0	1	0	1	0	0	–	SRST	1	–	MONO	CHSL	OS1	OS0
Register 21	R	0	0	1	0	1	0	1	–	–	–	–	–	DZ1	DZ0	–
Register 22	R	0	0	1	0	1	1	0	–	–	–	–	–	–	ZFGR	ZFGL

NOTE: –: Function is disabled. No operation even if data bit is set

### DMF[1:0]: Analog FIR Performance Selection

Default value: 00

DMF[1:0]	Analog FIR Performance Select
00	FIR-1 (default)
01	FIR-2
10	FIR-3
11	FIR-4

Plots for the four analog FIR filter responses are shown in the *ANALOG FIR FILTER PERFORMANCE IN DSD MODE* section of this data sheet.

### OS[1:0]: Analog-FIR Operation Speed Selection

Default value: 00

OS[1:0]	Operation Speed Select
00	$f_{DBCK}$ (default)
01	$f_{DBCK}/2$
10	Reserved
11	$f_{DBCK}/4$

The OS bits in the DSD mode select the operating rate of the analog FIR. The OS bits must be set before setting the DSD bit to 1.

**THEORY OF OPERATION**

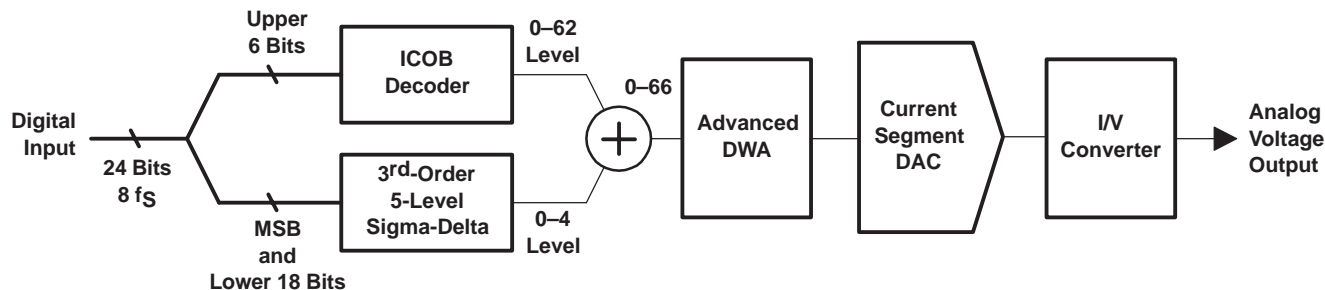

**Figure 48. Advanced Segment DAC With I/V Converter**

The DSD1793 uses TI’s advanced segment DAC architecture to achieve excellent dynamic performance and improved tolerance to clock jitter. The DSD1793 provides balanced voltage outputs.

Digital input data via the digital filter is separated into 6 upper bits and 18 lower bits. The 6 upper bits are converted to inverted complementary offset binary (ICOB) code. The lower 18 bits, in association with the MSB, are processed by a five-level third-order delta-sigma modulator operated at  $64 f_s$  by default. The 1 level of the modulator is equivalent to the 1 LSB of the ICOB code converter. The data groups processed in the ICOB converter and third-order delta-sigma modulator are summed together to an up to 66-level digital code, and then processed by data-weighted averaging (DWA) to reduce the noise produced by element mismatch. The data of up to 66 levels from the DWA is converted to an analog output in the differential-current segment section.

This architecture has overcome the various drawbacks of conventional multibit processing and also achieves excellent dynamic performance.

CONSIDERATIONS FOR APPLICATION CIRCUITS

PCB Layout Guidelines

A typical PCB floor plan for the DSD1793 is shown in Figure 49. A ground plane is recommended, with the analog and digital sections being isolated from one another using a split or cut in the circuit board. The DSD1793 must be oriented with the digital I/O pins facing the ground plane split/cut to allow for short, direct connections to the digital audio interface and control signals originating from the digital section of the board. Separate power supplies are recommended for the digital and analog sections of the board. This prevents the switching noise present on the digital supply from contaminating the analog power supply and degrading the dynamic performance of the D/A converters. In cases where a common 5-V supply would be used for the analog and digital sections, an inductance (RF choke, ferrite bead) must be placed between the analog and digital 5-V supply connections to avoid coupling of the digital switching noise into the analog circuitry. Figure 50 shows the recommended approach for single-supply applications.

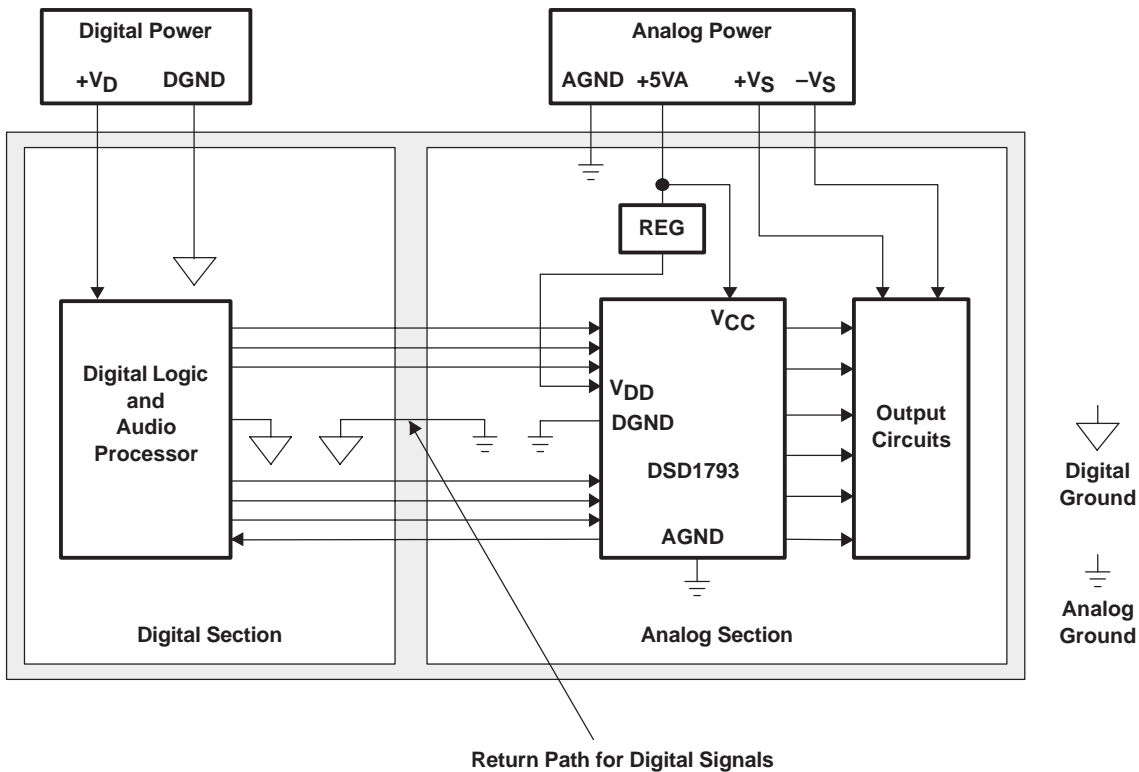
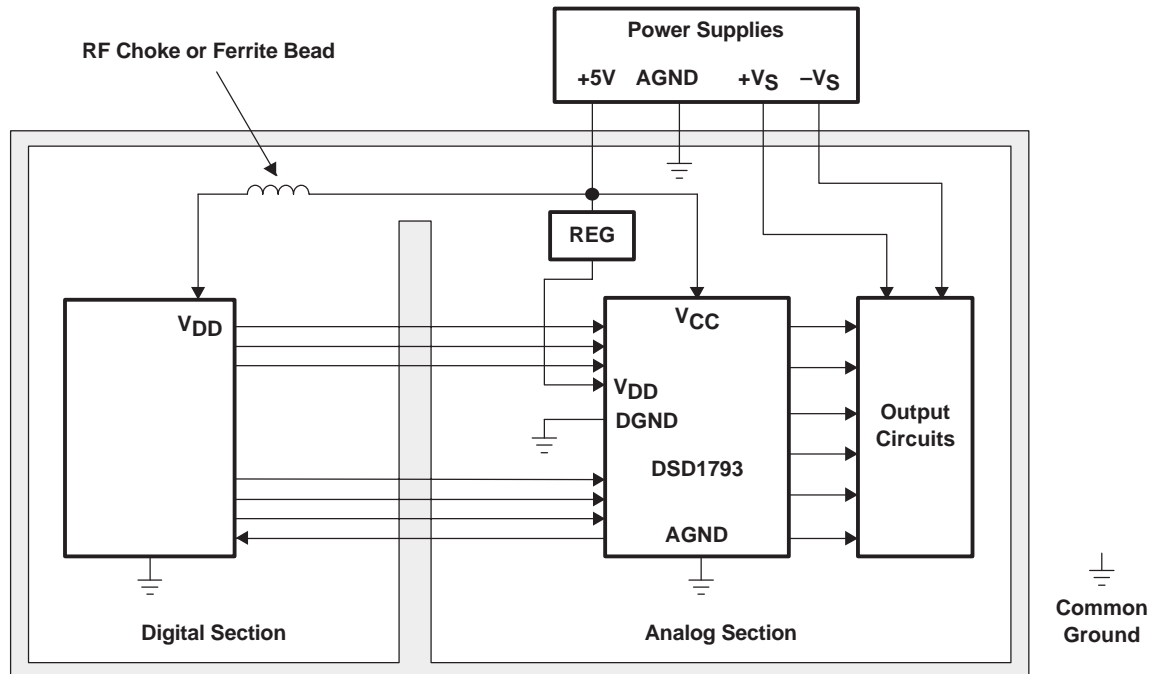

Figure 49. Recommended PCB Layout



**Figure 50. Single-Supply PCB Layout**

### Bypass and Decoupling Capacitor Requirements

Various sized decoupling capacitors can be used, with no special tolerances being required. All capacitors must be located as close as possible to the appropriate pins of the DSD1793 to reduce noise pickup from surrounding circuitry. Aluminum electrolytic capacitors that are designed for hi-fi audio applications are recommended for larger values, while metal film or monolithic ceramic capacitors are used for smaller values.

### Post-LPF Design

By proper choice of the operational amplifier and resistors used in the post-LPF circuit, excellent performance of the DSD1793 should be achieved. To obtain 0.001% THD+N and 113 dB signal-to-noise-ratio audio performance, the THD+N and input noise performance of the operational amplifier should be considered. This is because the input noise of the operational amplifier contributes directly to the output noise level of the application. The  $V_{OUT}$  pin of the DSD1793 and the input resistor of the post-LPF circuit must be connected as closely as possible.

Out-of-band noise level and attenuated sampling spectrum level are much lower than for typical delta-sigma type DACs due to the combination of a high-performance digital filter and advanced segment DAC architecture. The use of a second-order or third-order post-LPF is recommended for the post-LPF of the DSD1793. The cutoff frequency of the post-LPF depends on the application. For example, there are many sampling-rate operations such as  $f_S = 44.1$  kHz on CDDA,  $f_S = 96$  kHz on DVD-M,  $f_S = 192$  kHz on DVD-A,  $f_S = 64$  kHz on DSD (SACD).

**PACKAGING INFORMATION**

Orderable Device	Status <sup>(1)</sup>	Package Type	Package Drawing	Pins	Package Qty	Eco Plan <sup>(2)</sup>	Lead/Ball Finish	MSL Peak Temp <sup>(3)</sup>
DSD1793DB	ACTIVE	SSOP	DB	28	47	Green (RoHS & no Sb/Br)	CU NIPDAU	Level-1-260C-UNLIM
DSD1793DBG4	ACTIVE	SSOP	DB	28	47	Green (RoHS & no Sb/Br)	CU NIPDAU	Level-1-260C-UNLIM
DSD1793DBR	ACTIVE	SSOP	DB	28	2000	Green (RoHS & no Sb/Br)	CU NIPDAU	Level-1-260C-UNLIM
DSD1793DBRG4	ACTIVE	SSOP	DB	28	2000	Green (RoHS & no Sb/Br)	CU NIPDAU	Level-1-260C-UNLIM

<sup>(1)</sup> The marketing status values are defined as follows:

**ACTIVE:** Product device recommended for new designs.

**LIFEBUY:** TI has announced that the device will be discontinued, and a lifetime-buy period is in effect.

**NRND:** Not recommended for new designs. Device is in production to support existing customers, but TI does not recommend using this part in a new design.

**PREVIEW:** Device has been announced but is not in production. Samples may or may not be available.

**OBSOLETE:** TI has discontinued the production of the device.

<sup>(2)</sup> Eco Plan - The planned eco-friendly classification: Pb-Free (RoHS), Pb-Free (RoHS Exempt), or Green (RoHS & no Sb/Br) - please check <http://www.ti.com/productcontent> for the latest availability information and additional product content details.

**TBD:** The Pb-Free/Green conversion plan has not been defined.

**Pb-Free (RoHS):** TI's terms "Lead-Free" or "Pb-Free" mean semiconductor products that are compatible with the current RoHS requirements for all 6 substances, including the requirement that lead not exceed 0.1% by weight in homogeneous materials. Where designed to be soldered at high temperatures, TI Pb-Free products are suitable for use in specified lead-free processes.

**Pb-Free (RoHS Exempt):** This component has a RoHS exemption for either 1) lead-based flip-chip solder bumps used between the die and package, or 2) lead-based die adhesive used between the die and leadframe. The component is otherwise considered Pb-Free (RoHS compatible) as defined above.

**Green (RoHS & no Sb/Br):** TI defines "Green" to mean Pb-Free (RoHS compatible), and free of Bromine (Br) and Antimony (Sb) based flame retardants (Br or Sb do not exceed 0.1% by weight in homogeneous material)

<sup>(3)</sup> MSL, Peak Temp. -- The Moisture Sensitivity Level rating according to the JEDEC industry standard classifications, and peak solder temperature.

**Important Information and Disclaimer:**The information provided on this page represents TI's knowledge and belief as of the date that it is provided. TI bases its knowledge and belief on information provided by third parties, and makes no representation or warranty as to the accuracy of such information. Efforts are underway to better integrate information from third parties. TI has taken and continues to take reasonable steps to provide representative and accurate information but may not have conducted destructive testing or chemical analysis on incoming materials and chemicals. TI and TI suppliers consider certain information to be proprietary, and thus CAS numbers and other limited information may not be available for release.

In no event shall TI's liability arising out of such information exceed the total purchase price of the TI part(s) at issue in this document sold by TI to Customer on an annual basis.

**TAPE AND REEL INFORMATION**



**QUADRANT ASSIGNMENTS FOR PIN 1 ORIENTATION IN TAPE**



\*All dimensions are nominal

Device	Package Type	Package Drawing	Pins	SPQ	Reel Diameter (mm)	Reel Width W1 (mm)	A0 (mm)	B0 (mm)	K0 (mm)	P1 (mm)	W (mm)	Pin1 Quadrant
DSD1793DBR	SSOP	DB	28	2000	330.0	17.4	8.5	10.8	2.4	12.0	16.0	Q1

**TAPE AND REEL BOX DIMENSIONS**



\*All dimensions are nominal

Device	Package Type	Package Drawing	Pins	SPQ	Length (mm)	Width (mm)	Height (mm)
DSD1793DBR	SSOP	DB	28	2000	336.6	336.6	28.6



DB (R-PDSO-G\*\*)

PLASTIC SMALL-OUTLINE

28 PINS SHOWN



- NOTES: A. All linear dimensions are in millimeters.  
 B. This drawing is subject to change without notice.  
 C. Body dimensions do not include mold flash or protrusion not to exceed 0,15.  
 D. Falls within JEDEC MO-150

## IMPORTANT NOTICE

Texas Instruments Incorporated and its subsidiaries (TI) reserve the right to make corrections, modifications, enhancements, improvements, and other changes to its products and services at any time and to discontinue any product or service without notice. Customers should obtain the latest relevant information before placing orders and should verify that such information is current and complete. All products are sold subject to TI's terms and conditions of sale supplied at the time of order acknowledgment.

TI warrants performance of its hardware products to the specifications applicable at the time of sale in accordance with TI's standard warranty. Testing and other quality control techniques are used to the extent TI deems necessary to support this warranty. Except where mandated by government requirements, testing of all parameters of each product is not necessarily performed.

TI assumes no liability for applications assistance or customer product design. Customers are responsible for their products and applications using TI components. To minimize the risks associated with customer products and applications, customers should provide adequate design and operating safeguards.

TI does not warrant or represent that any license, either express or implied, is granted under any TI patent right, copyright, mask work right, or other TI intellectual property right relating to any combination, machine, or process in which TI products or services are used. Information published by TI regarding third-party products or services does not constitute a license from TI to use such products or services or a warranty or endorsement thereof. Use of such information may require a license from a third party under the patents or other intellectual property of the third party, or a license from TI under the patents or other intellectual property of TI.

Reproduction of TI information in TI data books or data sheets is permissible only if reproduction is without alteration and is accompanied by all associated warranties, conditions, limitations, and notices. Reproduction of this information with alteration is an unfair and deceptive business practice. TI is not responsible or liable for such altered documentation. Information of third parties may be subject to additional restrictions.

Resale of TI products or services with statements different from or beyond the parameters stated by TI for that product or service voids all express and any implied warranties for the associated TI product or service and is an unfair and deceptive business practice. TI is not responsible or liable for any such statements.

TI products are not authorized for use in safety-critical applications (such as life support) where a failure of the TI product would reasonably be expected to cause severe personal injury or death, unless officers of the parties have executed an agreement specifically governing such use. Buyers represent that they have all necessary expertise in the safety and regulatory ramifications of their applications, and acknowledge and agree that they are solely responsible for all legal, regulatory and safety-related requirements concerning their products and any use of TI products in such safety-critical applications, notwithstanding any applications-related information or support that may be provided by TI. Further, Buyers must fully indemnify TI and its representatives against any damages arising out of the use of TI products in such safety-critical applications.

TI products are neither designed nor intended for use in military/aerospace applications or environments unless the TI products are specifically designated by TI as military-grade or "enhanced plastic." Only products designated by TI as military-grade meet military specifications. Buyers acknowledge and agree that any such use of TI products which TI has not designated as military-grade is solely at the Buyer's risk, and that they are solely responsible for compliance with all legal and regulatory requirements in connection with such use.

TI products are neither designed nor intended for use in automotive applications or environments unless the specific TI products are designated by TI as compliant with ISO/TS 16949 requirements. Buyers acknowledge and agree that, if they use any non-designated products in automotive applications, TI will not be responsible for any failure to meet such requirements.

Following are URLs where you can obtain information on other Texas Instruments products and application solutions:

### Products

Amplifiers	<a href="http://amplifier.ti.com">amplifier.ti.com</a>
Data Converters	<a href="http://dataconverter.ti.com">dataconverter.ti.com</a>
DSP	<a href="http://dsp.ti.com">dsp.ti.com</a>
Clocks and Timers	<a href="http://www.ti.com/clocks">www.ti.com/clocks</a>
Interface	<a href="http://interface.ti.com">interface.ti.com</a>
Logic	<a href="http://logic.ti.com">logic.ti.com</a>
Power Mgmt	<a href="http://power.ti.com">power.ti.com</a>
Microcontrollers	<a href="http://microcontroller.ti.com">microcontroller.ti.com</a>
RFID	<a href="http://www.ti-rfid.com">www.ti-rfid.com</a>
RF/IF and ZigBee® Solutions	<a href="http://www.ti.com/lprf">www.ti.com/lprf</a>

### Applications

Audio	<a href="http://www.ti.com/audio">www.ti.com/audio</a>
Automotive	<a href="http://www.ti.com/automotive">www.ti.com/automotive</a>
Broadband	<a href="http://www.ti.com/broadband">www.ti.com/broadband</a>
Digital Control	<a href="http://www.ti.com/digitalcontrol">www.ti.com/digitalcontrol</a>
Medical	<a href="http://www.ti.com/medical">www.ti.com/medical</a>
Military	<a href="http://www.ti.com/military">www.ti.com/military</a>
Optical Networking	<a href="http://www.ti.com/opticalnetwork">www.ti.com/opticalnetwork</a>
Security	<a href="http://www.ti.com/security">www.ti.com/security</a>
Telephony	<a href="http://www.ti.com/telephony">www.ti.com/telephony</a>
Video & Imaging	<a href="http://www.ti.com/video">www.ti.com/video</a>
Wireless	<a href="http://www.ti.com/wireless">www.ti.com/wireless</a>

Mailing Address: Texas Instruments, Post Office Box 655303, Dallas, Texas 75265  
Copyright © 2008, Texas Instruments Incorporated