

**181-012-126**

Product Series  
Basic Number  
Dash Number  
(Table I)

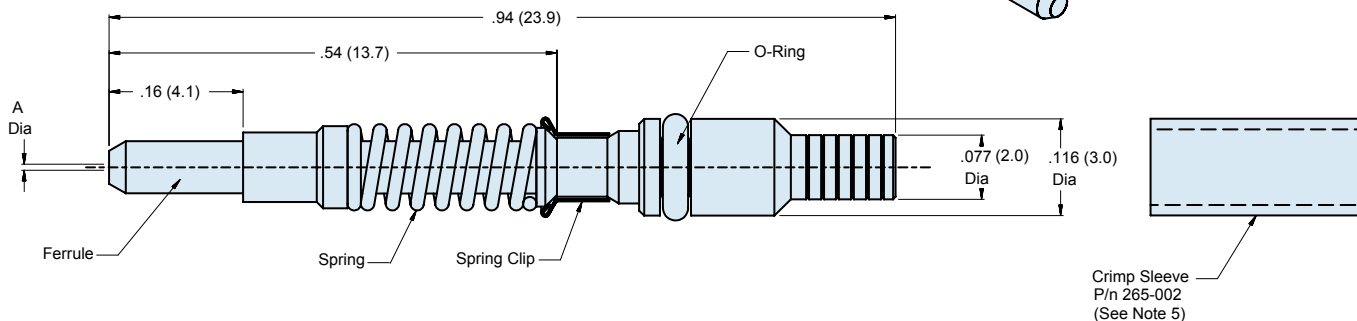
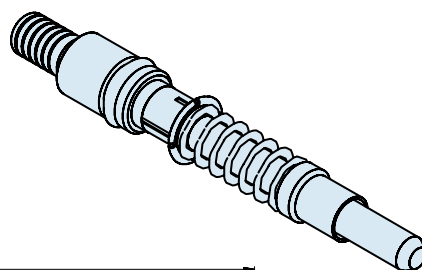

**APPLICATION NOTES**

1. Assembly packaged in plastic bag and tag identified with manufacturer's name and part number.
2. Material/Finish:  
 Ferrule: Zirconia Ceramic/N.A.  
 Protective Cover: Spring Alloy/Nickel  
 Terminus Assembly: Stainless Steel/Passivate  
 Spring Material: Stainless Steel Passivate  
 Spring Clip: Spring Alloy/N.A.  
 O-Ring: Fluorosilicone  
 Crimp Sleeve: Brass Alloy/Nickel
3. Alignment Sleeve with Protective Cover and Crimp Sleeve may be ordered separately (Table II).
4. Consult factory for termination and assembly tools/procedures.
5. Metric dimensions (mm) are in parentheses.

**181-012**  
**Fiber Optic Pin Terminus**  
**Size 16 Front Release**



Custom  
 Connector  
 System

**TABLE I: DASH NUMBER**

Assembly Dash No.	Fiber Size Core/Cladding	A Dia (mm)
125	9/125 (Singlemode)	.125
126	50/125	.126
126	62.5/125	.126
142	100/140	.142
156	62.5/125/155 (Polyimide)	.156
175	100/140/172 (Polyimide)	.175
233	200/225	.233
236	200/230	.236
280	200/280	.286
440	400/440	.448

**TABLE II: TERMINUS ACCESSORIES**

Assembly Dash No.	Terminus Accessories
265-002	Crimp Sleeve
182-015	Removal Tool
182-005P	Pin terminus Polishing Tool
182-014	Insertion Tool, 90°
182-013	Insertion Tool, Straight
182-012	Crimp Tool