

181-039
M29504/14
Size 16 MIL-PRF-28876 Type Fiber Optic Pin Terminus



M28876

Size 16 M29504/14 Fiber Optic Pin Terminus for MIL-PRF-28876 Connectors



Part Number	ØA (Microns)	Fiber Type	Fiber Size Core/Cladding (Microns)	Mil-Spec Part Number (Reference)
181-039-1250C	125.0	Single Mode	9/125	M29504/14-4140C
181-039-1255C	125.5	Single Mode	9/125	N/A
181-039-1260C	126.0	Single Mode	9/125	M29504/14-4141C
		Multi Mode	50/125, 62.5/125	M29504/14-4131C
181-039-1270C	127.0	Multi Mode	50/125, 62.5/125	M29504/14-4132C
181-039-1420C	142.0	Multi Mode	100/140	M29504/14-4135C
Consult factory for additional sizes				

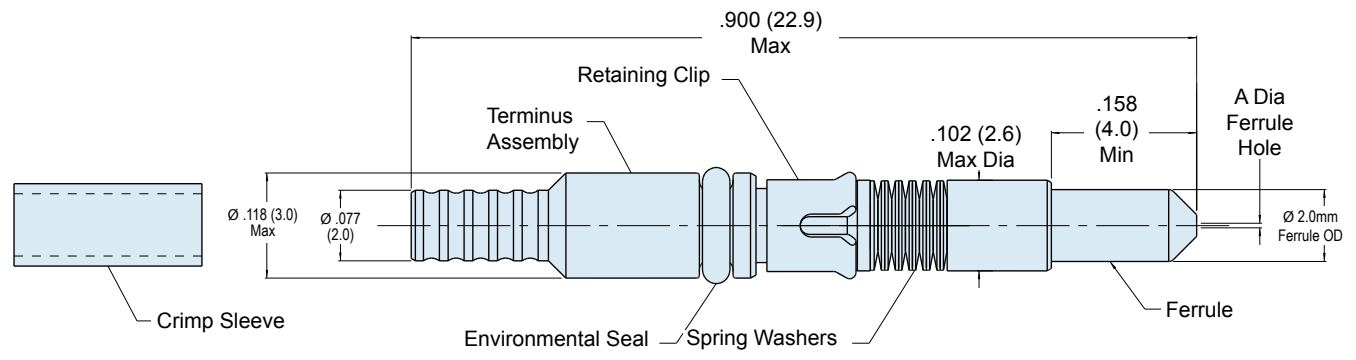

Tools and Accessories	
Part Number	Terminus Accessory
265-008	Crimp Sleeve Ø2.4mm Max Jacket (Mil-Spec Type)

Material and Finish
 Ferrule: Zirconia Ceramic
 Terminus Assembly: Stainless Steel/ Passivate
 Retaining Clip, Spring Washers: Spring Alloy
 Seal: Fluorosilicone
 Crimp Sleeve: Brass Alloy/Nickel

Notes
 Crimp sleeve is supplied with terminus assembly and may be ordered separately (see Table II). For terminus less crimp sleeve, omit **C** from end of part number.

Assembly
 See Glenair GAP-036 for termination procedure and assembly tools.
 Dummy terminus part number: 181-051