



Product Specification

10Gb SFP+ 850nm Limiting Transceiver

TRX10GVP2010

APPLICATIONS

10G Ethernet 10GBASE-SR/SW

MergeOptics SFP+ optical transceiver TRXGVP2010 is compliant with the current SFP+ MSA specifications (SFF-8431 and SFF-8432) and with 10GBASE-SR/SW per IEEE 802.3ae. It is RoHS 6/6 compliant per Directive 2002/95/EC and laser class 1 safety compliant per IEC/CDRH.

The sub watt power consumption and the excellent EMI performance allow system design with high port density.

SUPPORTED STANDARDS

Application	Standard	Data Rate
10G Ethernet LAN	IEEE 802.3ae 10GBASE-SR	10.3125GBd
10G Ethernet WAN	IEEE 802.3ae 10GBASE-SW	9.95328GBd



FEATURES & BENEFITS

- Hot pluggable SFP+ optical transceiver
- 10G Ethernet
- Data rate transparent from 9.95Gbps to 11.3Gbps
- Low power consumption, <0.6W typ.
- Excellent EMI performance
- Transmission distance up to 300m OM3 MMF
- 0°C to +70°C case operating temperature
- 850nm VCSEL laser
- Duplex LC connector
- Laser Class 1
- RoHS 6/6 compliant



■ TABLE OF CONTENTS

■ Table of Contents	2
■ Functional Description	3
■ Electrical Characteristics	4
Absolute Maximum Ratings	4
Recommended Operating Conditions	4
Low Speed Characteristics	4
SFI Module Transmitter Input Characteristics	5
SFI Module Receiver Output Characteristics	5
■ Optical Characteristics	6
General Parameters	6
Optical Transmitter	6
Optical Receiver	6
■ Application Information	7
Connector Pinout	7
Electrical Pin Definition	7
Application Schematics	8
Interfacing the Transceiver	9
Digital Optical Monitoring	9
Module Outline	10
■ Ordering Information	10
■ Related Information & Compliance	11
■ Eye Safety	11
■ Sales Contacts	12



FUNCTIONAL DESCRIPTION

The transmit path is based on an AC coupled 100 ohm differentially terminated driver coupled to an 850nm VCSEL. Laser output may be disabled by pulling the transmitter disable (TX_DIS) line high which is its default state when leaving input floating due to an internal pull-up resistor. A fault condition is raised upon detection of an abnormal laser state.

The receive path consists of a receiver optical sub-assembly (ROSA) for optical to electrical conversion, followed by a limiting amplifier boosting the electrical signal. A loss of signal (LOS) status line provides information to facilitate easy link detection.

Complete digital optical monitoring is implemented in compliance to SFF-8472 and made accessible via the 2-wire interface providing real time information about all important module parameters and status information.

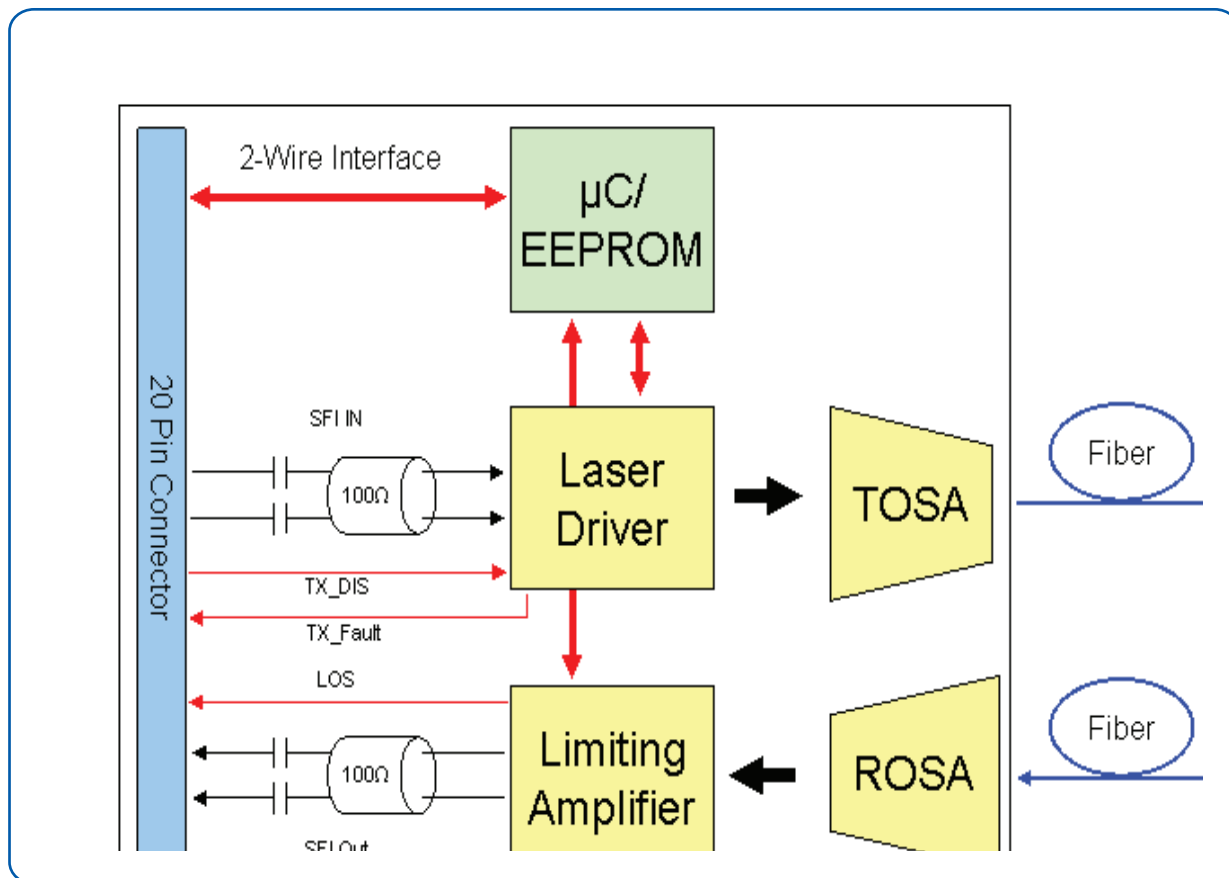



ELECTRICAL CHARACTERISTICS

Absolute Maximum Ratings

Rating	Conditions	Symbol	Min	Max	Units
Storage Ambient Temperature		ϑ_{stg}	-40	+85	$\infty^{\circ}\text{C}$
Powered Case Temperature		ϑ_c	0	+75	$\infty^{\circ}\text{C}$
Operating Relative Humidity	Non condensing	RH	0	95	%
Supply Voltage Range		V_{CC3}	-0.5	4.0	V

Any stress beyond the maximum ratings may result in permanent damage to the device. Specifications are guaranteed only under recommended operating conditions.

Recommended Operating Conditions

Parameter	Conditions	Symbol	Min	Typ	Max	Units
Operating Case Temperature	altitude of < 3km	ϑ_{Case}	0		+70	$\infty^{\circ}\text{C}$
Power Supply Voltage		V_{CC3}	3.135	3.30	3.465	V
DC Common Mode Voltage		V_{CM}	0		3.6	V

Low Speed Characteristics

Parameter	Conditions	Symbol	Min	Typ	Max	Units
Supply Current Transmitter	@ V_{CCTX}	$I_{V_{CCTX}}$			100	mA
Supply Current Receiver	@ V_{CCRX}	$I_{V_{CCRX}}$			120	mA
Power Consumption				0.55	0.75	W
TX_Fault, RX_LOS	Host Vcc Range 2V ñ 3.47V	V_{OL}	0		0.4	V
		V_{OH}	Host_Vcc ñ 0.5		Host_Vcc + 0.3	
TX_Dis, RS0, RS1	Low Voltage TTL	V_{IL}	-0.3		0.8	
		V_{IH}	2.0		$V_{CC3} + 0.3$	
SCL, SDA	Host Vcc Range 3.14V ñ 3.47V	V_{IL}	-0.3		$V_{CC3}^* + 0.3$	
		V_{IH}	$V_{CC3}^* + 0.7$		$V_{CC3} + 0.5$	
		V_{OL}	0.0		0.4	
		V_{OH}	Host_Vcc ñ 0.5		Host_Vcc + 0.3	

FUNCTIONAL DESCRIPTION

SFI Module Transmitter Input Characteristics

Parameter	Conditions	Symbol	Min	Typ	Max	Units
Nominal Data Rate ^V		I _D		10.3125G		bd
Reference Differential Input Impedance		Z _d		100		Ω
Input AC Common Mode Input Voltage			02		5	mV (RMS)
Differential Input Voltage Swing		V _{ID}	150		900	mV
Differential Input S-parameter	0.01 ñ 3.9GHz	SDD11	1 ¹⁾		-10	dB
	3.9 ñ 11.1GHz				1 ¹⁾	
Differential to Common Mode Conversion ²⁾	0.01 ñ 11.1Ghz	SCD11			-10	dB
Total Jitter		TJ			0.28	UI(p-p)
Data Dependant Jitter		DDJ			0.1	UI(p-p)
Uncorrelated Jitter		UJ			0.023	RMS

1) Differential Return Loss given by equation $SDD11(dB) = -8 + 13.33 \log_{10}(f/5.5)$, with f in GHz

2) Common mode reference impedance is 25Ω. Differential to common mode conversion relates to generation of EMI

SFI Module Receiver Output Characteristics

Parameter	Conditions	Symbol	Min	Typ	Max	Units
Nominal Data Rate				10.3125		Gbd
Reference Differential Output Impedance		Z _d		100		
Termination Mismatch		ΔZ _d			5	%
Output AC Common Mode Voltage					15	mV (RMS)
Differential Output Amplitude	R _{Load} = 100Ohm, Differential	V _{OSPP}	350		800	mV
Output Rise and Fall time	20% to 80%	t _{RH} , t _{FH}			35	ps
Differential Output S-parameter	0.01 ñ 3.9GHz	SDD22			-10	dB
	3.9 ñ 11.1GHz				1 ¹⁾	
Common Mode Output Return Loss ²⁾	0.01 ñ 6.5GHz	SCC22			-7	dB
	6.5 ñ 11.1GHz				-3	
Deterministic Jitter		DJ			0.42	UI(p-p)
Total Jitter	See SFP+ MSA	TJ			0.7	UI(p-p)

1) Return Loss given by equation $Sxx22(dB) = -8 + 13.33 \log_{10}(f/5.5)$, with f in GHz

2) Common mode reference impedance is 25Ω. Common mode return loss helps absorb reflection and noise improving EMI



OPTICAL CHARACTERISTICS

General Parameters

Parameter	Conditions	Min Modal Bandwidth (MHz*km)	Symbol	Min	Typical 1GBd	Typical 10GBd	Units
Operating Range	62.5 μm MMF	160	I _{OP}	2	220	26	m
	50 μm MMF	400		2	500	66	
	62.5 μm MMF	200		0.5	275	33	
	50 μm MMF	500		0.5	550	82	
	50 μm MMF	2000		0.5	X	300	

Optical Transmitter

Parameter	Conditions	Symbol	Min	Typ	Max	Units
Nominal Wavelength		λ _{TRP}	840	850	860	nm
Spectral Width		Δλ			0.45	
Average Launch Power		P _{avg}	-7.3		-1	dBm
Extinction Ratio		ER	3.5			dB
Relative Intensity Noise		RIN			-128	dB/Hz

Optical Receiver

Parameter	Conditions	Symbol	Min	Typ	Max	Units
Maximum Input Power		P _{MAX}			-1	dBm
Center Wavelength		λ _C	840	850	860	nm
Receiver Sensitivity	PRBS 2 ³¹ -1, BER < 1*10 ⁻¹² @10.3125GBd	P _{IN(OMA)}	-11.1			dBm
Stressed Receiver Sensitivity	PRBS 2 ³¹ -1, BER < 1*10 ⁻¹² @ 10.3125GBd	P _{IN(OMA)}	-7.5			dBm
Loss of Signal		P _{av_as}	-30			dBm
		P _{OMA_deas}			-13	

Note: The specified characteristics are met within the recommended range of operating. Unless otherwise noted typical data are quoted at nominal voltages and +25°C ambient temperature.

APPLICATION INFORMATION

Connector Pinout

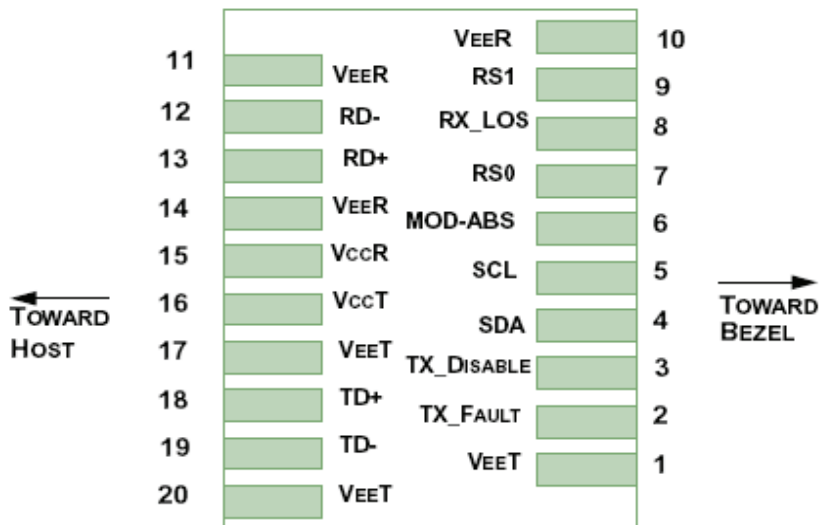

Electrical Pin Definition

PIN	Logic	Symbol	Name / Description	Note
1		VeeT	Module Transmitter Ground	1
2	LVTTL-O	TX_Fault	Module Transmitter Fault	
3	LVTTL-I	TX_Dis	Transmitter Disable; Turns off transmitter laser output	
4	LVTTL-I	SCL	2-Wire Serial Interface Clock	2
5	LVTTL-I/O	SDA	2-Wire Serial Interface Data Line	2
6		MOD_DEF0	Module Definition, Grounded in the module	
7	LVTTL-I	RS0	Receiver Rate Select	
8	LVTTL-O	RX_LOS	Receiver Loss of Signal Indication Active LOW	
9	LVTTL-I	RS1	Transmitter Rate Select	
10		VeeR	Module Receiver Ground	1
11		VeeR	Module Receiver Ground	1
12	CML-O	RD-	Receiver Inverted Data Output	
13	CML-O	RD+	Receiver Data Output	
14		VeeR	Module Receiver Ground	1
15		VccR	Module Receiver 3.3 V Supply	
16		VccT	Module Receiver 3.3 V Supply	
17		VeeT	Module Transmitter Ground	1
18	CML-I	TD-	Transmitter Inverted Data Input	
19	CML-I	TD+	Receiver Non-Inverted Data Output	
20		VeeT	Module Transmitter Ground	1

1. Module ground pins GND are isolated from the module case.
2. Shall be pulled up with 4.7K-10Kohms to a voltage between 3.15V and 3.45V on the host board.

APPLICATION SCHEMATICS

Recommended electrical connections to transceiver are shown below.

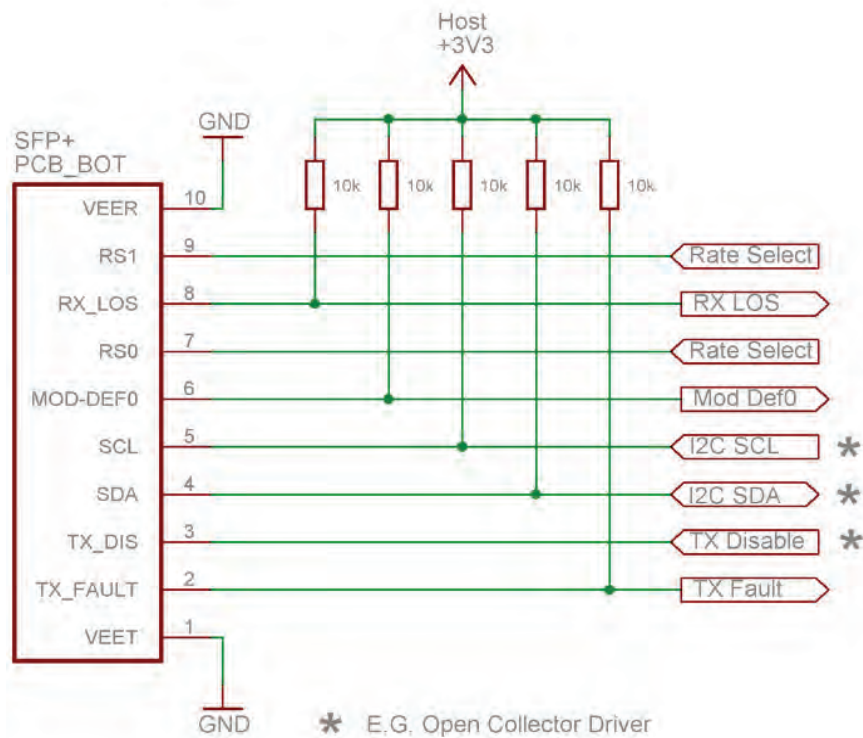
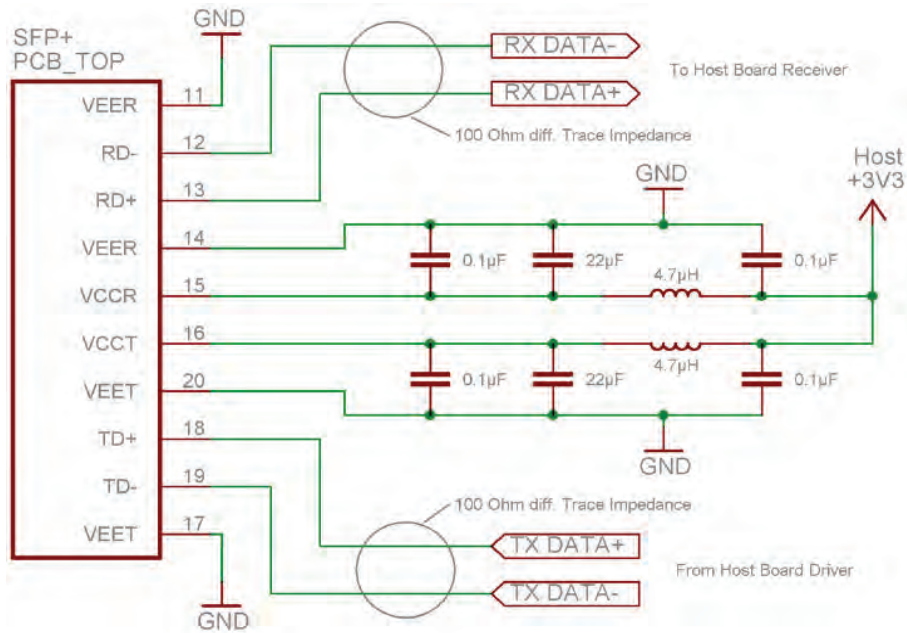

INTERFACING THE TRANSCEIVER

Communication is done by a serial 2-wire interface compatible to the I2C bus protocol. Refer to SFF-8472 for a more detailed register explanation of the registers:

Base Address A0h	
Register	Content
0 - 95	Serial Transceiver ID as defined in SFP MSA
96 - 127	MergeOptics Specific
128 - 255	Reserved

Base Address A2h	
Register	Content
0 - 55	Alarm & Warnings Thresholds & Limits
56 - 95	External calibration constants (not used)
96 ñ 119	Values from real time diagnostic monitoring
120 ñ 127	Not used
128 ñ 247	Customer specific, writable area
248 - 255	Not used

Digital Optical Monitoring

The transceiver offers the ability to monitor important module parameter during operation. All five parameters listed below are continuously monitored for getting information about the current module status. All data is calibrated internally; there is no need for external post processing.

Temperature

Internally measured temperature data is represented as two's complement of a signed 16-bit value in increments of 1/256 °C over a range of -40 to +100°C. Accuracy is better than +/-3%.

Supply Voltage (VCC)

Internally measured supply voltage. Represented as a 16-bit unsigned integer with the voltage defined as the full 16 bit value (0 ñ 65535) with LSB equal to 100 µVolt, which yields to a total range of 0 to +6.55 Volts. Accuracy is better than +/-3%.

Laser Bias Current

The VCSEL bias current is represented as a 16 bit unsigned integer with the current defined as the full 16-bit value (0 ñ 65535) with LSB equal to 2 µA, valid range is 0 to 20 mA. Accuracy is better than +/-10%.

Optical Transmitter Power

TX output power measurement is based on internal monitor diode feedback. Represented as a 16-bit unsigned integer with the power defined as the full 16 bit value (0 ñ 65535) with LSB equal to 0.1 µW. Accuracy is better than +/-3dB over a range of $P_{av_{min}}$ to $P_{av_{max}}$.

Receiver Optical Power

RX input power measurement is based on photodiode diode current. Represented as a 16-bit unsigned integer with the power defined as the full 16 bit value (0 ñ 65535) with LSB equal to 0.1 µW. Accuracy is better than +/-3dB over a range of -12dBm to -1dBm.

Note: The specified characteristics are met within the recommended range of operating conditions regarding temperature and voltage.

MODULE OUTLINE

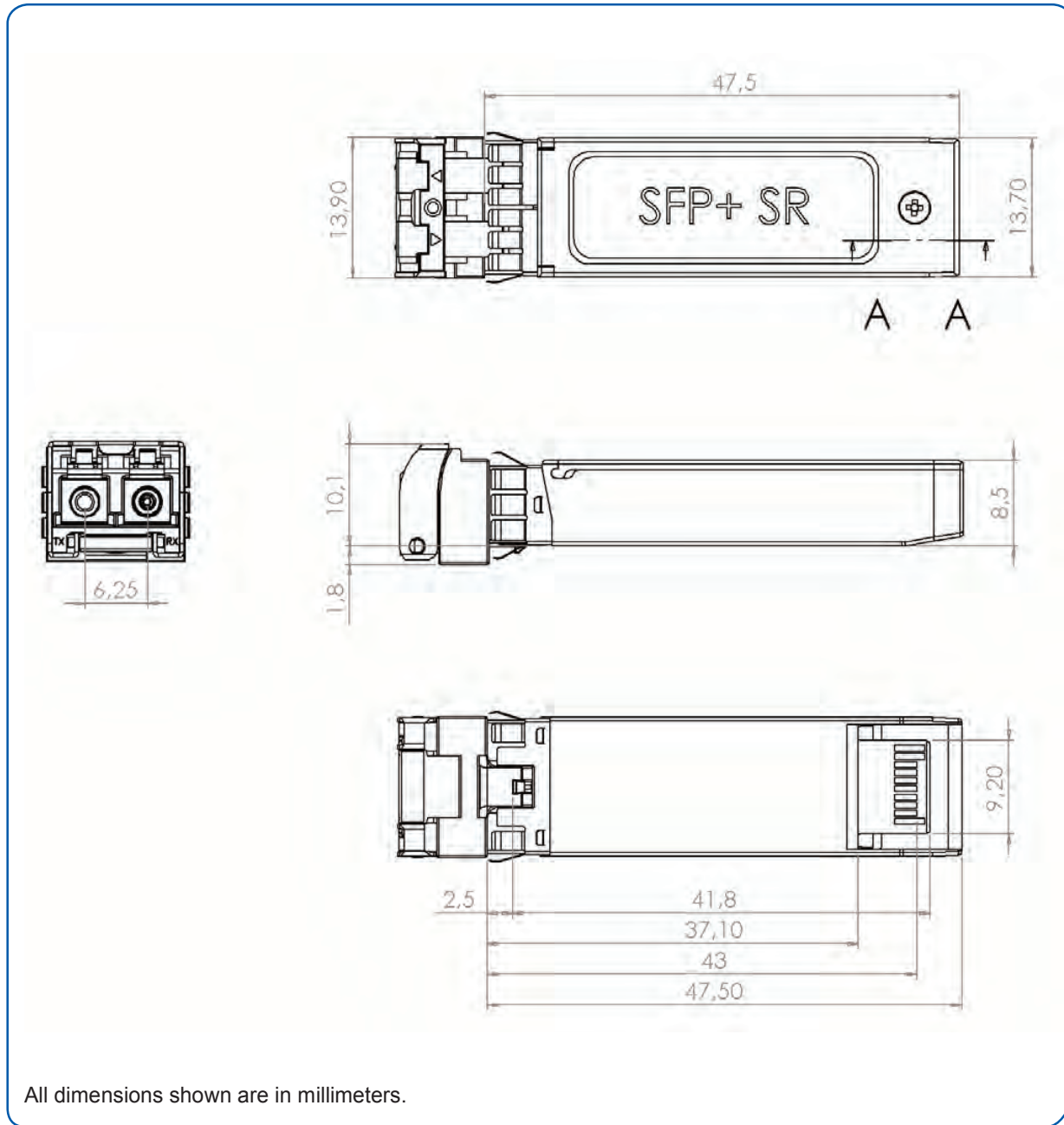

ORDERING INFORMATION

Application	Standard	Part Number
10G Ethernet LAN	IEEE 802.3ae 10GBASE-SR	TRX10GVP2010 TRX10GVP2010CA01 (HP customized)
10G Ethernet WAN	IEEE 802.3ae 10GBASE-SW	TRX10GVP2010

RELATED INFORMATION & COMPLIANCE

Requirements	Standard
RoHS	RoHS 6/6 Directive 2002/95/EC Amendment 4054 (2005/747/EC)
EMI (Module)	FCC Part 15, Class B EN 55022 Class B CISPR 22

Requirements	Standard	Value
ESD (Electrical connector)	JEDEC JESD22-A114-B	1kV
ESD (Module case)	Air Discharge EN61000-4-2 criterion B	15kV
ESD (Module case)	Contact Discharge EN61000-4-2 criterion B	8kV

EYE SAFETY

This laser based multimode transceiver is a Class 1p product. It complies with IEC 60825-1 Edition 2 and FDA performance standards for laser products (21 CFR 1040.10 and 1040.11) except for deviations pursuant to Laser Notice 50, dated July 26, 2001.

CLASS 1 LASER PRODUCT

To meet laser safety requirements the transceiver shall be operated within the Absolute Maximum Ratings.

Note: All adjustments have been made at the factory prior to shipment of the devices. No maintenance or alteration to the device is required. Tampering with or modifying the performance of the device will result in voided product warranty. Failure to adhere to the above restrictions could result in a modification that is considered an act of "manufacturing", and will require, under law, recertification of the modified product with the U.S. Food and Drug Administration (ref. 21 CFR 1040.10 (i)).

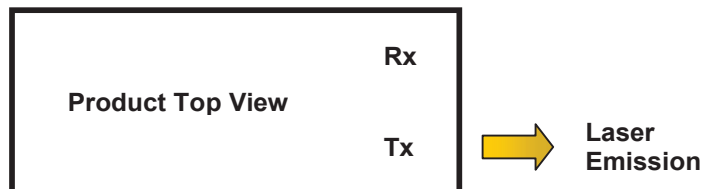

Wavelength >	840 nm
Accessible Emission Limit (as defined by IEC: 7 mm aperture at 70 mm distance)	<743 μ W

▀ EUROPE

FCI Deutschland GmbH

Wernerwerkdamm 16
13629 Berlin, Germany
Ph: +49 30 750 795 00
Fax: +49 30 386 37 54

▀ AMERICAS

MergeOptics

1551 McCarthy Blvd, Suite 116
Milpitas, CA 95035 USA
Phone: 408-493-9970

More information about FCI's complete range of High Speed Input/Output products can be found on www.fciconnect.com/hsio

For more information about e-catalog or FCI sales offices, headquarters, agents and local distributors, visit www.fciconnect.com

