



Low Power Triple and Quad Channels Digital Isolators

 Check for Samples: [ISO7631FM](#), [ISO7640FM](#), [ISO7641FM](#), [ISO7631FC](#), [ISO7640FC](#), [ISO7641FC](#)

FEATURES

- Signaling Rate: 150 Mbps (M-Grade), 25 Mbps (C-Grade)
- Robust Design with Integrated Noise Filter (C-Grade)
- Low Power Consumption, Typical I_{CC} per Channel (3.3V Supplies):
 - ISO7631FC: 1.5 mA at 10 Mbps
 - ISO7640FC: 1.1 mA at 10 Mbps
 - ISO7641FC: 1.3 mA at 10 Mbps
- Extremely low $I_{CC_disable}$ (C-Grade)
- Low Propagation Delay: 7 ns Typical (M-Grade)
- Output Defaults to Low-state in fail-safe mode
- Wide Temperature Range: -40°C to 125°C
- 50 KV/ μs Transient Immunity, Typical
- Long Life with SiO_2 Isolation barrier
- Operates From 2.7V (M-Grade), 3.3 V and 5 V Supply and Logic Levels
- Wide Body SOIC-16 Package

APPLICATIONS

- Optocoupler Replacement in:
 - Industrial Fieldbus
 - Profibus
 - Modbus
 - DeviceNet™ Data Buses
 - Servo Control Interface
 - Motor Control
 - Power Supplies
 - Battery Packs

SAFETY AND REGULATORY APPROVALS

- 6000 V_{PK} / 4243 V_{RMS} for 1 Minute per UL 1577 (approved)
- VDE Approval for DIN EN 60747-5-2 (VDE 0884 Rev. 2), 1414 V_{PK} Working Voltage (approved)
- CSA Component Acceptance Notice 5A, IEC 60601-1 Medical Standard (approved)
- 5 KV_{RMS} Reinforced Insulation per TUV for EN/UL/CSA 60950-1 and EN/UL/CSA 61010-1 (approved)

DESCRIPTION

ISO7631F, ISO7640F and ISO7641F provide galvanic isolation up to 6 KV_{PK} for 1 minute per UL and VDE. These devices are also certified up to 5 KV_{RMS} Reinforced isolation at a working voltage of 400 V_{RMS} per end equipment standards EN/UL/CSA 60950-1 and 61010-1. ISO7631F has 3 channels with two forward and one reverse direction channels. ISO7640F and ISO7641F are quad channel isolators; ISO7640F has four forward and ISO7641F has three forward and one reverse direction channels. Suffix F indicates that output defaults to Low-state in fail-safe conditions (see [Table 1](#)). M-Grade devices are high speed isolators capable of 150 Mbps data rate with fast propagation delays whereas C-Grade devices can run up to 25 Mbps data rate with low power consumption and integrated filters for noise-prone applications. C-Grade devices are recommended for lower speed applications where input noise pulses of less than 10 ns duration need to be suppressed or lower power consumption is critical.

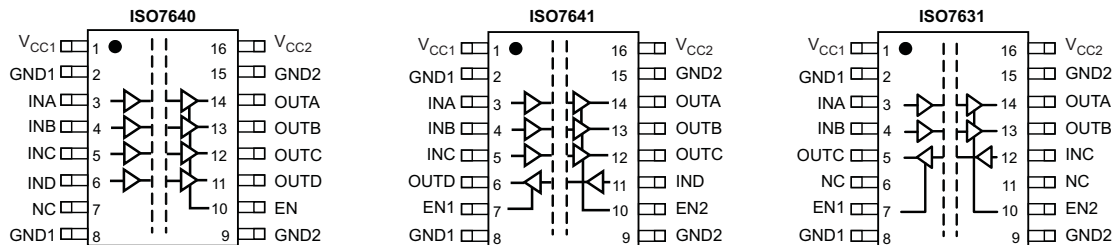

Please be aware that an important notice concerning availability, standard warranty, and use in critical applications of Texas Instruments semiconductor products and disclaimers thereto appears at the end of this data sheet.



These devices have limited built-in ESD protection. The leads should be shorted together or the device placed in conductive foam during storage or handling to prevent electrostatic damage to the MOS gates.

DESCRIPTION CONTINUED

Each isolation channel has a logic input and output buffer separated by a silicon dioxide (SiO₂) insulation barrier. Used in conjunction with isolated power supplies, these devices prevent noise currents on a data bus or other circuits from entering the local ground and interfering with or damaging sensitive circuitry. The devices have TTL input thresholds and can operate from 2.7 V (M-Grade), 3.3 V and 5 V supplies. All inputs are 5 V tolerant when supplied from 3.3 V or 2.7 V supplies.

PIN DESCRIPTIONS

NAME	PIN			I/O	DESCRIPTION
	ISO7640	ISO7641	ISO7631		
INA	3	3	3	I	Input, channel A
INB	4	4	4	I	Input, channel B
INC	5	5	12	I	Input, channel C
IND	6	11	-	I	Input, channel D
OUTA	14	14	14	O	Output, channel A
OUTB	13	13	13	O	Output, channel B
OUTC	12	12	5	O	Output, channel C
OUTD	11	6	-	O	Output, channel D
EN	10	-	-	I	Enables (when input is High or Open) or Disables (when input is Low) OUTA, OUTB, OUTC and OUTD of ISO7640
EN1	-	7	7	I	Enables (when input is High or Open) or Disables (when input is Low) OUTD of ISO7641 and OUTC of ISO7631
EN2	-	10	10	I	Enables (when input is High or Open) or Disables (when input is Low) OUTA, OUTB, and OUTC of ISO7641 Enables (when input is High or Open) or Disables (when input is Low) OUTA and OUTB of ISO7631
V _{CC1}	1	1	1	-	Power supply, V _{CC1}
V _{CC2}	16	16	16	-	Power supply, V _{CC2}
GND1	2,8	2,8	2,8	-	Ground connection for V _{CC1}
GND2	9,15	9,15	9,15	-	Ground connection for V _{CC2}
NC	7	-	6,11	-	No Connect pins are floating with no internal connection

Table 1. FUNCTION TABLE⁽¹⁾

INPUT V _{CC}	OUTPUT V _{CC}	INPUT (IN _x)	OUTPUT ENABLE (EN _x)	OUTPUT (OUT _x)
PU	PU	H	H or Open	H
		L	H or Open	L
		X	L	Z
		Open	H or Open	L
PD	PU	X	H or Open	L
PD	PU	X	L	Z
PU	PD	X	X	Z

(1) PU = Powered Up (V_{CC} ≥ 2.7 V); PD = Powered Down (V_{CC} ≤ 2.4 V); X = Irrelevant; H = High Level; L = Low Level; Z = High Impedance

AVAILABLE OPTIONS

PRODUCT	RATED ISOLATION	PACKAGE	INPUT THRESHOLD	DATA RATE and FILTER	CHANNEL DIRECTION	MARKED AS	ORDERING NUMBER
ISO7631FM	6 KV _{PK} / 5 KV _{RMS} ⁽¹⁾	DW-16	1.5 V TTL (CMOS Compatible)	150 Mbps, No Noise Filter	2 Forward, 1 Reverse	ISO7631FM	ISO7631FMDW (rail)
ISO7631FMDWR (reel)							
ISO7640FM					4 Forward, 0 Reverse	ISO7640FM	ISO7640FMDW (rail)
							ISO7640FMDWR (reel)
ISO7641FM				3 Forward, 1 Reverse	ISO7641FM	ISO7641FMDW (rail)	
ISO7641FMDWR (reel)							
ISO7631FC				2 Forward, 1 Reverse	ISO7631FC	ISO7631FCDW (rail)	
						ISO7631FCDWR (reel)	
ISO7640FC	4 Forward, 0 Reverse	ISO7640FC	ISO7640FCDW (rail)				
			ISO7640FCDWR (reel)				
ISO7641FC	3 Forward, 1 Reverse	ISO7641FC	ISO7641FCDW (rail)				
ISO7641FCDWR (reel)							
				25 Mbps, Integrated Noise Filter			

(1) See the [Regulatory Information](#) table for detailed isolation ratings.

ABSOLUTE MAXIMUM RATINGS⁽¹⁾

PARAMETER	VALUE		UNIT
	MIN	MAX	
Supply voltage ⁽²⁾	V _{CC1} , V _{CC2}		V
Voltage	IN _x , OUT _x , EN _x		V
Output Current, I _O			mA
Electrostatic discharge	Human Body Model	ESDA, JEDEC JS-001-2012	kV
	Field-Induced Charged Device Model	JEDEC JESD22-C101E	kV
	Machine Model	JEDEC JESD22-A115-A	V
Maximum junction temperature, T _J			°C
Storage temperature, T _{STG}			°C

- (1) Stresses beyond those listed under *absolute maximum ratings* may cause permanent damage to the device. These are stress ratings only and functional operation of the device at these or any other conditions beyond those indicated under *Recommended Operating Conditions* is not implied. Exposure to absolute-maximum-rated conditions for extended periods may affect device reliability.
- (2) All voltage values except differential I/O bus voltages are with respect to the local ground terminal (GND1 or GND2) and are peak voltage values.

RECOMMENDED OPERATING CONDITIONS

PARAMETER		MIN	TYP	MAX	UNIT
Supply voltage	V _{CC1} , V _{CC2}	M-Grade	2.7	5.5	V
		C-Grade	3	5.5	
High-level output current	I _{OH}	-4			mA
Low-level output current	I _{OL}			4	mA
High-level input voltage	V _{IH}	2		V _{CC}	V
Low-level input voltage	V _{IL}	0		0.8	V
Input pulse duration	t _{ui}	M-Grade: ≥3V-Operation	6.67		ns
		M-Grade: <3V-Operation	10		
		C-Grade: ≥3V-Operation	40		
Signaling rate	1 / t _{ui}	M-Grade: ≥3V-Operation	0	150	Mbps
		M-Grade: <3V-Operation	0	100	
		C-Grade: ≥3V-Operation	0	25	
Junction temperature	T _J	-40		136	°C
Ambient temperature	T _A	-40	25	125	°C

THERMAL INFORMATION

THERMAL METRIC ⁽¹⁾		ISO76xx	UNITS
		DW (16 Pins)	
θ _{JA}	Junction-to-ambient thermal resistance	72	°C/W
θ _{JC(top)}	Junction-to-case(top) thermal resistance	38	
θ _{JB}	Junction-to-board thermal resistance	39	
ψ _{JT}	Junction-to-top characterization parameter	9.4	
ψ _{JB}	Junction-to-board characterization parameter	n/a	
θ _{JC(bottom)}	Junction-to-case(bottom) thermal resistance	n/a	
P _D	Maximum Device Power Dissipation	V _{CC1} = V _{CC2} = 5.5V, T _J = 150°C, C _L = 15pF Input a 75 MHz 50% duty cycle square wave	mW

- (1) For more information about traditional and new thermal metrics, see the *IC Package Thermal Metrics* application report, [SPRA953](#).

ELECTRICAL CHARACTERISTICS

V_{CC1} and V_{CC2} at $5\text{ V} \pm 10\%$ (over recommended operating conditions unless otherwise noted)

ISO7631F, ISO7640F, ISO7641F		TEST CONDITIONS	M-Grade			C-Grade			UNIT
PARAMETER	MIN		TYP	MAX	MIN	TYP	MAX		
V_{OH}	High-level output voltage	$I_{OH} = -4\text{ mA}$; see Figure 1	$V_{CCx}^{(1)} - 0.8$	4.8		$V_{CCx}^{(1)} - 0.8$	4.7		V
		$I_{OH} = -20\text{ }\mu\text{A}$; see Figure 1	$V_{CCx}^{(1)} - 0.1$		5	$V_{CCx}^{(1)} - 0.1$		5	
V_{OL}	Low-level output voltage	$I_{OL} = 4\text{ mA}$; see Figure 1		0.2	0.4		0.3	0.5	V
		$I_{OL} = 20\text{ }\mu\text{A}$; see Figure 1		0	0.1		0	0.1	
$V_{I(HYS)}$	Input threshold voltage hysteresis			450			450		mV
I_{IH}	High-level input current	$V_{IH} = V_{CC}$ at INx or ENx			10			10	μA
I_{IL}	Low-level input current	$V_{IL} = 0\text{ V}$ at INx or ENx	-10			-10			
CMTI	Common-mode transient immunity	$V_I = V_{CC}$ or 0 V ; see Figure 4	25	75		25	75		kV/ μs

(1) V_{CCx} is the supply voltage, V_{CC1} or V_{CC2} , for the output channel that is being measured.

SWITCHING CHARACTERISTICS

V_{CC1} and V_{CC2} at $5\text{ V} \pm 10\%$ (over recommended operating conditions unless otherwise noted)

ISO7631F, ISO7640F, ISO7641F		TEST CONDITIONS	M-Grade			C-Grade			UNIT
PARAMETER	MIN		TYP	MAX	MIN	TYP	MAX		
t_{PLH} , t_{PHL}	Propagation delay time	See Figure 1	3.5	7	10.5	11	17	28	ns
PWD ⁽¹⁾	Pulse width distortion [$t_{PHL} - t_{PLH}$]				2			3	
$t_{sk(o)}$ ⁽²⁾	Channel-to-channel output skew time	Same-direction Channels			2			3	ns
		Opposite-direction Channels			3			4	
$t_{sk(pp)}$ ⁽³⁾	Part-to-part skew time			4.5			13		
t_r	Output signal rise time	See Figure 1		1.6			2.8		ns
t_f	Output signal fall time			1			2.9		
t_{PHZ}	Disable Propagation Delay, high-to-high impedance output	See Figure 2		5	16		8	20	ns
t_{PLZ}	Disable Propagation Delay, low-to-high impedance output			5	16		7	20	
t_{PZH}	Enable Propagation Delay, high impedance-to-high output			4	16		11000	22000 ⁽⁴⁾	
t_{PZL}	Enable Propagation Delay, high impedance-to-low output			4	16		8	20	
t_{fs}	Fail-safe output delay time from input data or power loss	See Figure 3		9.5			9		μs

(1) Also known as Pulse Skew.

(2) $t_{sk(o)}$ is the skew between outputs of a single device with all driving inputs connected together and the outputs switching in the same direction while driving identical loads.

(3) $t_{sk(pp)}$ is the magnitude of the difference in propagation delay times between any terminals of different devices switching in the same direction while operating at identical supply voltages, temperature, input signals and loads.

(4) The enable signal rate for C-grade devices should be $\leq 45\text{ Kbps}$.

SUPPLY CURRENT

V_{CC1} and V_{CC2} at 5 V \pm 10% (over recommended operating conditions unless otherwise noted)

ISO7631F			M-Grade			C-Grade			UNIT	
PARAMETER	TEST CONDITIONS		MIN	TYP	MAX	MIN	TYP	MAX		
I_{CC1}	Disable	EN1 = EN2 = 0 V	2.5		4	1.1		1.9	mA	
I_{CC2}			3.7		5.4	1.5		2.6		
I_{CC1}	DC to 1 Mbps	DC Signal: $V_I = V_{CC}$ or 0 V AC Signal: All channels switching with square wave clock input; $C_L = 15$ pF	2.6		4.1	1.8		2.7		
I_{CC2}			3.8		5.5	2.6		3.9		
I_{CC1}	10 Mbps		3.3		4.5	2.7		3.7		
I_{CC2}			4.9		6.6	3.9		5.3		
I_{CC1}	25 Mbps		4.5		6	4.1		5.4		
I_{CC2}			6.8		9	5.9		7.8		
I_{CC1}	150 Mbps		15		19.5	Not Applicable				
I_{CC2}			22		30	Not Applicable				
ISO7640F			M-Grade			C-Grade			UNIT	
I_{CC1}	Disable		EN = 0 V	0.6		1.2	0.6			1.2
I_{CC2}		4.5			6.6	1.3		2.6		
I_{CC1}	DC to 1 Mbps	DC Signal: $V_I = V_{CC}$ or 0 V, AC Signal: All channels switching with square wave clock input; $C_L = 15$ pF	0.7		1.3	0.7		1.3		
I_{CC2}			4.6		6.7	3		4.6		
I_{CC1}	10 Mbps		1.1		2	1.3		2		
I_{CC2}			6.6		10.5	5.2		7		
I_{CC1}	25 Mbps		1.9		3	2.5		3.6		
I_{CC2}			9.7		14.7	8.5		11		
I_{CC1}	150 Mbps		8.2		14.5	Not Applicable				
I_{CC2}			35		58	Not Applicable				
ISO7641F			M-Grade			C-Grade			UNIT	
I_{CC1}	Disable		EN1 = EN2 = 0 V	2.6		4.2	1.2			2.1
I_{CC2}		4.2			6.8	1.6		2.6		
I_{CC1}	DC to 1 Mbps	DC Signal: $V_I = V_{CC}$ or 0 V, AC Signal: All channels switching with square wave clock input; $C_L = 15$ pF	2.7		4.3	1.8		2.8		
I_{CC2}			4.3		6.9	3.1		4.2		
I_{CC1}	10 Mbps		3.6		4.9	3		4		
I_{CC2}			6		8.2	4.9		6.1		
I_{CC1}	25 Mbps		5.1		6.6	4.8		6		
I_{CC2}			8.8		11.4	7.7		9.5		
I_{CC1}	150 Mbps		17		22	Not Applicable				
I_{CC2}			31		42	Not Applicable				

ELECTRICAL CHARACTERISTICS

 V_{CC1} at 5 V \pm 10% and V_{CC2} at 3.3 V \pm 10% (over recommended operating conditions unless otherwise noted)

ISO7631F, ISO7640F, ISO7641F		TEST CONDITIONS		M-Grade			C-Grade			UNIT
PARAMETER				MIN	TYP	MAX	MIN	TYP	MAX	
V_{OH}	High-level output voltage	$I_{OH} = -4$ mA; see Figure 1	OUTx on V_{CC1} (5V) side	$V_{CC1} - 0.8$	4.8		$V_{CC1} - 0.8$	4.7		V
			OUTx on V_{CC2} (3.3V) side	$V_{CC2} - 0.4$	3		$V_{CC2} - 0.6$	2.9		
		$I_{OH} = -20$ μ A; see Figure 1	OUTx on V_{CC1} (5V) side	$V_{CC1} - 0.1$	5		$V_{CC1} - 0.1$	5		
			OUTx on V_{CC2} (3.3V) side	$V_{CC2} - 0.1$	3.3		$V_{CC2} - 0.1$	3.3		
V_{OL}	Low-level output voltage	$I_{OL} = 4$ mA; see Figure 1			0.2	0.4		0.3	0.5	V
		$I_{OL} = 20$ μ A; see Figure 1			0	0.1		0	0.1	
$V_{I(HYS)}$	Input threshold voltage hysteresis				430			430		mV
I_{IH}	High-level input current	$V_{IH} = V_{CC}$ at INx or ENx				10				μ A
I_{IL}	Low-level input current	$V_{IL} = 0$ V at INx or ENx			-10			-10		
CMTI	Common-mode transient immunity	$V_I = V_{CC}$ or 0 V; see Figure 4			25	50		25	50	kV/ μ s

SWITCHING CHARACTERISTICS

 V_{CC1} at 5 V \pm 10% and V_{CC2} at 3.3 V \pm 10% (over recommended operating conditions unless otherwise noted)

ISO7631F, ISO7640F, ISO7641F		TEST CONDITIONS		M-Grade			C-Grade			UNIT
PARAMETER				MIN	TYP	MAX	MIN	TYP	MAX	
t_{PLH}, t_{PHL}	Propagation delay time	See Figure 1		4	8	13	11	18	32	ns
PWD ⁽¹⁾	Pulse width distortion $ t_{PHL} - t_{PLH} $						2		3.5	
$t_{sk(o)}$ ⁽²⁾	Channel-to-channel output skew time	Same-direction Channels				2.5		4.5		
		Opposite-direction Channels				3.5		5.5		
$t_{sk(pp)}$ ⁽³⁾	Part-to-part skew time					6		15		
t_r	Output signal rise time	See Figure 1				2		3.6		
t_f	Output signal fall time					1.2		3.3		
t_{PHZ}	Disable Propagation Delay, high-to-high impedance output	See Figure 2				6.5	17	9	20	ns
t_{PLZ}	Disable Propagation Delay, low-to-high impedance output					6.5	17	8	20	
t_{PZH}	Enable Propagation Delay, high impedance-to-high output					5.5	17	11000	22000 ⁽⁴⁾	
t_{PZL}	Enable Propagation Delay, high impedance-to-low output					5.5	17	10	30	
t_{fs}	Fail-safe output delay time from input data or power loss	See Figure 3				9.5		8.5		μ s

(1) Also known as Pulse Skew.

(2) $t_{sk(o)}$ is the skew between outputs of a single device with all driving inputs connected together and the outputs switching in the same direction while driving identical loads.

(3) $t_{sk(pp)}$ is the magnitude of the difference in propagation delay times between any terminals of different devices switching in the same direction while operating at identical supply voltages, temperature, input signals and loads.

(4) The enable signal rate for C-grade devices should be \leq 45 Kbps.

SUPPLY CURRENT

V_{CC1} at $5\text{ V} \pm 10\%$ and V_{CC2} at $3.3\text{V} \pm 10\%$ (over recommended operating conditions unless otherwise noted)

ISO7631F			M-Grade			C-Grade			UNIT		
PARAMETER	TEST CONDITIONS		MIN	TYP	MAX	MIN	TYP	MAX			
I_{CC1}	Disable	EN1 = EN2 = 0 V		2.5	4		1.1	1.9	mA		
I_{CC2}				2.7	3.7		0.7	1.3			
I_{CC1}	DC to 1 Mbps	DC Signal: $V_I = V_{CC}$ or 0 V AC Signal: All channels switching with square wave clock input; $C_L = 15\text{ pF}$		2.6	4.1		1.8	2.7			
I_{CC2}				2.8	3.8		1.8	2.6			
I_{CC1}	10 Mbps			3.3	4.5		2.7	3.7			
I_{CC2}				3.5	4.6		2.6	3.5			
I_{CC1}	25 Mbps			4.5	6		4.1	5.4			
I_{CC2}				4.7	5.9		3.8	5			
I_{CC1}	150 Mbps			15	19.5		Not Applicable				
I_{CC2}				14.6	19		Not Applicable				
ISO7640F			M-Grade			C-Grade					
I_{CC1}	Disable		EN = 0 V		0.6	1.2		0.6		1.2	mA
I_{CC2}					3.6	5.1		0.6		1.1	
I_{CC1}	DC to 1 Mbps		DC Signal: $V_I = V_{CC}$ or 0 V, AC Signal: All channels switching with square wave clock input; $C_L = 15\text{ pF}$		0.7	1.3		0.7		1.3	
I_{CC2}					3.7	5.2		2.1	3.2		
I_{CC1}	10 Mbps				1.1	2		1.3	2		
I_{CC2}				5	7.1		3.6	4.7			
I_{CC1}	25 Mbps			1.9	3		2.5	3.6			
I_{CC2}				6.9	11		5.7	9			
I_{CC1}	150 Mbps			8.2	14.5		Not Applicable				
I_{CC2}				24	40		Not Applicable				
ISO7641F				M-Grade			C-Grade				
I_{CC1}	Disable	EN1 = EN2 = 0 V			2.6	4.2		1.2	2.1	mA	
I_{CC2}				3.2	4.9		0.8	1.3			
I_{CC1}	DC to 1 Mbps	DC Signal: $V_I = V_{CC}$ or 0 V, AC Signal: All channels switching with square wave clock input; $C_L = 15\text{ pF}$		2.7	4.3		1.8	2.8			
I_{CC2}				3.3	5		2	2.9			
I_{CC1}	10 Mbps			3.6	4.9		3	4			
I_{CC2}				4.4	5.8		3.2	4.1			
I_{CC1}	25 Mbps			5.1	6.6		4.8	6			
I_{CC2}				6.1	7.6		5.1	7			
I_{CC1}	150 Mbps			17	22		Not Applicable				
I_{CC2}				20.6	26.5		Not Applicable				

ELECTRICAL CHARACTERISTICS

V_{CC1} at $3.3V \pm 10\%$ and V_{CC2} at $5V \pm 10\%$ (over recommended operating conditions unless otherwise noted)

ISO7631F, ISO7640F, ISO7641F		TEST CONDITIONS	M-Grade			C-Grade			UNIT	
PARAMETER			MIN	TYP	MAX	MIN	TYP	MAX		
V_{OH}	High-level output voltage	$I_{OH} = -4 \text{ mA}$; see Figure 1	OUTx on V_{CC1} (3.3 V) side	$V_{CC1}-0.4$	3		$V_{CC1}-0.6$	2.9	V	
			OUTx on V_{CC2} (5 V) side	$V_{CC2}-0.8$	4.8		$V_{CC2}-0.8$	4.7		
		$I_{OH} = -20 \text{ }\mu\text{A}$; see Figure 1	OUTx on V_{CC1} (3.3 V) side	$V_{CC1}-0.1$	3.3		$V_{CC1}-0.1$	3.3		
			OUTx on V_{CC2} (5 V) side	$V_{CC2}-0.1$	5		$V_{CC2}-0.1$	5		
V_{OL}	Low-level output voltage	$I_{OL} = 4 \text{ mA}$; see Figure 1		0.2	0.4	0.3	0.5	V		
		$I_{OL} = 20 \text{ }\mu\text{A}$; see Figure 1		0	0.1	0	0.1			
$V_{I(HYS)}$	Input threshold voltage hysteresis		430			430			mV	
I_{IH}	High-level input current	$V_{IH} = V_{CC}$ at INx or ENx		10			10			μA
I_{IL}	Low-level input current	$V_{IL} = 0 \text{ V}$ at INx or ENx	-10				-10			
CMTI	Common-mode transient immunity	$V_I = V_{CC}$ or 0 V ; see Figure 4	25	50		25	50		kV/ μs	

SWITCHING CHARACTERISTICS

V_{CC1} at $3.3 \text{ V} \pm 10\%$ and V_{CC2} at $5 \text{ V} \pm 10\%$ (over recommended operating conditions unless otherwise noted)

ISO7631F, ISO7640F, ISO7641F		TEST CONDITIONS	M-Grade			C-Grade			UNIT
PARAMETER			MIN	TYP	MAX	MIN	TYP	MAX	
t_{PLH}, t_{PHL}	Propagation delay time	See Figure 1	4	7.5	12.5	11	18.5	32	ns
PWD ⁽¹⁾	Pulse width distortion $ t_{PHL} - t_{PLH} $		2					2.5	
$t_{sk(o)}$ ⁽²⁾	Channel-to-channel output skew time	Same-direction Channels	2.5			4.5			
		Opposite-direction Channels	3.5			5.5			
$t_{sk(pp)}$ ⁽³⁾	Part-to-part skew time		6			15			
t_r	Output signal rise time	See Figure 1	1.7			2.9			ns
t_f	Output signal fall time		1.1			2.9			
t_{PHZ}	Disable Propagation Delay, high-to-high impedance output	See Figure 2	5.5			8			ns
t_{PLZ}	Disable Propagation Delay, low-to-high impedance output		5.5			7			
t_{PZH}	Enable Propagation Delay, high impedance-to-high output		4.5			11000 22000 ⁽⁴⁾			
t_{PZL}	Enable Propagation Delay, high impedance-to-low output		4.5			8			
t_{fs}	Fail-safe output delay time from input data or power loss	See Figure 3	9.5			7.5			μs

(1) Also known as Pulse Skew.

(2) $t_{sk(o)}$ is the skew between outputs of a single device with all driving inputs connected together and the outputs switching in the same direction while driving identical loads.

(3) $t_{sk(pp)}$ is the magnitude of the difference in propagation delay times between any terminals of different devices switching in the same direction while operating at identical supply voltages, temperature, input signals and loads.

(4) The enable signal rate for C-grade devices should be $\leq 45 \text{ Kbps}$.

SUPPLY CURRENT

V_{CC1} at $3.3V \pm 10\%$ and V_{CC2} at $5V \pm 10\%$ (over recommended operating conditions unless otherwise noted)

ISO7631F			M-Grade			C-Grade			UNIT
PARAMETER	TEST CONDITIONS		MIN	TYP	MAX	MIN	TYP	MAX	
I_{CC1}	Disable	EN1 = EN2 = 0 V			1.8	2.8	0.6 1.1		mA
I_{CC2}					3.7	5.4	1.5 2.6		
I_{CC1}	DC to 1 Mbps	DC Signal: $V_I = V_{CC}$ or 0 V AC Signal: All channels switching with square wave clock input; $C_L = 15$ pF			1.9	2.9	1.2 1.8		
I_{CC2}					3.8	5.5	2.6 3.9		
I_{CC1}	10 Mbps				2.4	3.4	1.8 2.6		
I_{CC2}					4.9	6.6	3.9 5.3		
I_{CC1}	25 Mbps				3.2	4.2	2.7 3.6		
I_{CC2}					6.8	9	5.9 7.8		
I_{CC1}	150 Mbps				9.3	12.5	Not Applicable		
I_{CC2}					22	30			
ISO7640F			M-Grade			C-Grade			
I_{CC1}	Disable		EN = 0 V			0.35	0.7	0.35 0.7	
I_{CC2}				4.5	6.6	1.3 2.6			
I_{CC1}	DC to 1 Mbps	DC Signal: $V_I = V_{CC}$ or 0 V, AC Signal: All channels switching with square wave clock input; $C_L = 15$ pF			0.4	0.8	0.4 0.8		
I_{CC2}					4.6	6.7	3 4.6		
I_{CC1}	10 Mbps				0.7	1.2	0.7 1.2		
I_{CC2}					6.6	10.5	5.2 7		
I_{CC1}	25 Mbps				1.1	2	1.5 2.2		
I_{CC2}					9.7	14.7	8.5 11		
I_{CC1}	150 Mbps				5	8.5	Not Applicable		
I_{CC2}					35	58			
ISO7641F			M-Grade			C-Grade			
I_{CC1}	Disable		EN1 = EN2 = 0 V			1.9	2.9	0.7 1.1	
I_{CC2}				4.2	6.8	1.6 2.6			
I_{CC1}	DC to 1 Mbps	DC Signal: $V_I = V_{CC}$ or 0 V, AC Signal: All channels switching with square wave clock input; $C_L = 15$ pF			2	3	1.2 1.9		
I_{CC2}					4.3	6.9	3.1 4.2		
I_{CC1}	10 Mbps				2.5	3.5	2 2.8		
I_{CC2}					6	8.2	4.9 6.1		
I_{CC1}	25 Mbps				3.4	4.5	3.1 4		
I_{CC2}					8.8	11.4	7.7 9.5		
I_{CC1}	150 Mbps				10.5	14.5	Not Applicable		
I_{CC2}					31	42			

ELECTRICAL CHARACTERISTICS

V_{CC1} and V_{CC2} at 3.3 V \pm 10% (over recommended operating conditions unless otherwise noted)

ISO7631F, ISO7640F, ISO7641F		TEST CONDITIONS	M-Grade			C-Grade			UNIT
PARAMETER	MIN		TYP	MAX	MIN	TYP	MAX		
V_{OH}	High-level output voltage	$I_{OH} = -4$ mA; see Figure 1	$V_{CCx}^{(1)} - 0.4$	3		$V_{CCx}^{(1)} - 0.6$	2.9	V	
		$I_{OH} = -20$ μ A; see Figure 1	$V_{CCx}^{(1)} - 0.1$	3.3		$V_{CCx}^{(1)} - 0.1$	3.3		
V_{OL}	Low-level output voltage	$I_{OL} = 4$ mA; see Figure 1		0.2	0.4		0.3	0.5	V
		$I_{OL} = 20$ μ A; see Figure 1		0	0.1		0	0.1	
$V_{I(HYS)}$	Input threshold voltage hysteresis			425			425	mV	
I_{IH}	High-level input current	$V_{IH} = V_{CC}$ at INx or ENx			10			10	μ A
I_{IL}	Low-level input current	$V_{IL} = 0$ V at INx or ENx	-10			-10			
CMTI	Common-mode transient immunity	$V_I = V_{CC}$ or 0 V; see Figure 4	25	50		25	50	kV/ μ s	

(1) V_{CCx} is the supply voltage, V_{CC1} or V_{CC2} , for the output channel that is being measured.

SWITCHING CHARACTERISTICS

V_{CC1} and V_{CC2} at 3.3 V \pm 10% (over recommended operating conditions unless otherwise noted)

ISO7631F, ISO7640F, ISO7641F		TEST CONDITIONS	M-Grade			C-Grade			UNIT
PARAMETER	MIN		TYP	MAX	MIN	TYP	MAX		
t_{PLH} , t_{PHL}	Propagation delay time	See Figure 1	4	8.5	14	12	23	35	ns
PWD ⁽¹⁾	Pulse width distortion [$t_{PHL} - t_{PLH}$]		2					3	
$t_{sk(o)}$ ⁽²⁾	Channel-to-channel output skew time	Same-direction Channels			3			5	
		Opposite-direction Channels			4			6	
$t_{sk(pp)}$ ⁽³⁾	Part-to-part skew time			6.5			16		
t_r	Output signal rise time	See Figure 1		2			3.7	ns	
t_f	Output signal fall time			1.3			3.4		
t_{PHZ}	Disable Propagation Delay, high-to-high impedance output	See Figure 2		6.5	17		9	20	ns
t_{PLZ}	Disable Propagation Delay, low-to-high impedance output			6.5	17		8	20	
t_{PZH}	Enable Propagation Delay, high impedance-to-high output			5.5	17		11000	22000 ⁽⁴⁾	
t_{PZL}	Enable Propagation Delay, high impedance-to-low output			5.5	17		10	30	
t_{fs}	Fail-safe output delay time from input data or power loss	See Figure 3		9.2			7.5	μ s	

(1) Also known as Pulse Skew.

(2) $t_{sk(o)}$ is the skew between outputs of a single device with all driving inputs connected together and the outputs switching in the same direction while driving identical loads.

(3) $t_{sk(pp)}$ is the magnitude of the difference in propagation delay times between any terminals of different devices switching in the same direction while operating at identical supply voltages, temperature, input signals and loads.

(4) The enable signal rate for C-grade devices should be \leq 45 Kbps.

SUPPLY CURRENT

V_{CC1} and V_{CC2} at 3.3 V \pm 10% (over recommended operating conditions unless otherwise noted)

ISO7631F			M-Grade			C-Grade			UNIT	
PARAMETER	TEST CONDITIONS		MIN	TYP	MAX	MIN	TYP	MAX		
I_{CC1}	Disable	EN1 = EN2 = 0 V		1.8	2.8		0.6	1.1	mA	
I_{CC2}				2.7	3.7		0.7	1.3		
I_{CC1}	DC to 1 Mbps	DC Signal: $V_I = V_{CC}$ or 0 V AC Signal: All channels switching with square wave clock input; $C_L = 15$ pF		1.9	2.9		1.2	1.8		
I_{CC2}				2.8	3.8		1.8	2.6		
I_{CC1}	10 Mbps			2.4	3.4		1.8	2.6		
I_{CC2}				3.5	4.6		2.6	3.5		
I_{CC1}	25 Mbps			3.2	4.2		2.7	3.6		
I_{CC2}				4.7	5.9		3.8	5		
I_{CC1}	150 Mbps			9.3	12.5		Not Applicable			
I_{CC2}				14.6	19		Not Applicable			
ISO7640F			M-Grade			C-Grade			mA	
I_{CC1}	Disable		EN = 0 V		0.35	0.7		0.35		0.7
I_{CC2}				3.6	5.1		0.6	1.1		
I_{CC1}	DC to 1 Mbps	DC Signal: $V_I = V_{CC}$ or 0 V, AC Signal: All channels switching with square wave clock input; $C_L = 15$ pF		0.4	0.8		0.4	0.8		
I_{CC2}				3.7	5.2		2.1	3.2		
I_{CC1}	10 Mbps			0.7	1.2		0.7	1.2		
I_{CC2}				5	7.1		3.6	4.7		
I_{CC1}	25 Mbps			1.1	2		1.5	2.2		
I_{CC2}				6.9	11		5.7	9		
I_{CC1}	150 Mbps			5	8.5		Not Applicable			
I_{CC2}				24	40		Not Applicable			
ISO7641F			M-Grade			C-Grade			mA	
I_{CC1}	Disable		EN1 = EN2 = 0 V		1.9	2.9		0.7		1.1
I_{CC2}				3.2	4.9		0.8	1.3		
I_{CC1}	DC to 1 Mbps	DC Signal: $V_I = V_{CC}$ or 0 V, AC Signal: All channels switching with square wave clock input; $C_L = 15$ pF		2	3		1.2	1.9		
I_{CC2}				3.3	5		2	2.9		
I_{CC1}	10 Mbps			2.5	3.5		2	2.8		
I_{CC2}				4.4	5.8		3.2	4.1		
I_{CC1}	25 Mbps			3.4	4.5		3.1	4		
I_{CC2}				6.1	7.6		5.1	7		
I_{CC1}	150 Mbps			10.5	14.5		Not Applicable			
I_{CC2}				20.6	26.5		Not Applicable			

ELECTRICAL CHARACTERISTICS

 V_{CC1} and V_{CC2} at 2.7 V⁽¹⁾ (over recommended operating conditions unless otherwise noted)

ISO7631F, ISO7640F, ISO7641F		TEST CONDITIONS	M-Grade			UNIT
PARAMETER			MIN	TYP	MAX	
V_{OH}	High-level output voltage	$I_{OH} = -4$ mA; see Figure 1	$V_{CC}^{(2)} - 0.5$	2.4		V
		$I_{OH} = -20$ μ A; see Figure 1	$V_{CC}^{(2)} - 0.1$	2.7		
V_{OL}	Low-level output voltage	$I_{OL} = 4$ mA; see Figure 1		0.2	0.4	V
		$I_{OL} = 20$ μ A; see Figure 1		0	0.1	
$V_{I(HYS)}$	Input threshold voltage hysteresis		350			mV
I_{IH}	High-level input current	$V_{IH} = V_{CC}$ at INx or ENx			10	μ A
I_{IL}	Low-level input current	$V_{IL} = 0$ V at INx or ENx	-10			
CMTI	Common-mode transient immunity	$V_I = V_{CC}$ or 0 V; see Figure 4	25	50		kV/ μ s

(1) Only M-Grade devices are recommended for operation down to 2.7 V supplies. For 2.7 V-operation, max data rate is 100 Mbps.

(2) V_{CCx} is the supply voltage, V_{CC1} or V_{CC2} , for the output channel that is being measured.

SWITCHING CHARACTERISTICS

 V_{CC1} and V_{CC2} at 2.7 V (over recommended operating conditions unless otherwise noted)

ISO7631F, ISO7640F, ISO7641F		TEST CONDITIONS	M-Grade			UNIT
PARAMETER			MIN	TYP	MAX	
t_{PLH}, t_{PHL}	Propagation delay time	See Figure 1	5	8	16	ns
PWD ⁽¹⁾	Pulse width distortion $ t_{PHL} - t_{PLH} $				2.5	
$t_{sk(o)}$ ⁽²⁾	Channel-to-channel output skew time	Same-direction Channels			4	ns
		Opposite-direction Channels			5	
$t_{sk(pp)}$ ⁽³⁾	Part-to-part skew time			8		
t_r	Output signal rise time	See Figure 1		2.3		ns
t_f	Output signal fall time			1.8		
t_{PHZ}	Disable Propagation Delay, high-to-high impedance output	See Figure 2		8	18	ns
t_{PLZ}	Disable Propagation Delay, low-to-high impedance output			8	18	
t_{PZH}	Enable Propagation Delay, high impedance-to-high output			7	18	
t_{PZL}	Enable Propagation Delay, high impedance-to-low output			7	18	
t_{fs}	Fail-safe output delay time from input data or power loss	See Figure 3		8.5		μ s

(1) Also known as Pulse Skew.

(2) $t_{sk(o)}$ is the skew between outputs of a single device with all driving inputs connected together and the outputs switching in the same direction while driving identical loads.

(3) $t_{sk(pp)}$ is the magnitude of the difference in propagation delay times between any terminals of different devices switching in the same direction while operating at identical supply voltages, temperature, input signals and loads.

SUPPLY CURRENT

V_{CC1} and V_{CC2} at 2.7 V (over recommended operating conditions unless otherwise noted)

ISO7631F			M-Grade			UNIT	
PARAMETER	TEST CONDITIONS		MIN	TYP	MAX		
I_{CC1}	Disable	EN1 = EN2 = 0 V		1.5	2.4	mA	
I_{CC2}				2.2	3.2		
I_{CC1}	DC to 1 Mbps	DC Signal: $V_I = V_{CC}$ or 0 V AC Signal: All channels switching with square wave clock input; $C_L = 15$ pF		1.6	2.5		
I_{CC2}				2.3	3.2		
I_{CC1}	10 Mbps			2	2.9		
I_{CC2}				3	3.9		
I_{CC1}	25 Mbps			2.7	3.7		
I_{CC2}				3.9	4.9		
I_{CC1}	100 Mbps			5.7	6.8		
I_{CC2}				8.6	12		
ISO7640F			M-Grade			UNIT	
I_{CC1}	Disable		EN = 0 V		0.2		0.6
I_{CC2}				3.3	5		
I_{CC1}	DC to 1 Mbps	DC Signal: $V_I = V_{CC}$ or 0 V, AC Signal: All channels switching with square wave clock input; $C_L = 15$ pF		0.2	0.7		
I_{CC2}				3.4	5.1		
I_{CC1}	10 Mbps			0.4	1.1		
I_{CC2}				4.4	6.8		
I_{CC1}	25 Mbps			0.8	1.8		
I_{CC2}				6	9.5		
I_{CC1}	100 Mbps			2.7	5		
I_{CC2}				14.2	21		
ISO7641F			M-Grade			UNIT	
I_{CC1}	Disable		EN1 = EN2 = 0 V		1.6		2.4
I_{CC2}				2.8	4.1		
I_{CC1}	DC to 1 Mbps	DC Signal: $V_I = V_{CC}$ or 0 V, AC Signal: All channels switching with square wave clock input; $C_L = 15$ pF		1.7	2.5		
I_{CC2}				2.9	4.2		
I_{CC1}	10 Mbps			2.1	3		
I_{CC2}				3.8	5		
I_{CC1}	25 Mbps			2.8	3.8		
I_{CC2}				5.2	6.7		
I_{CC1}	100 Mbps			6.4	7.5		
I_{CC2}				11.8	15.5		

PARAMETER MEASUREMENT INFORMATION

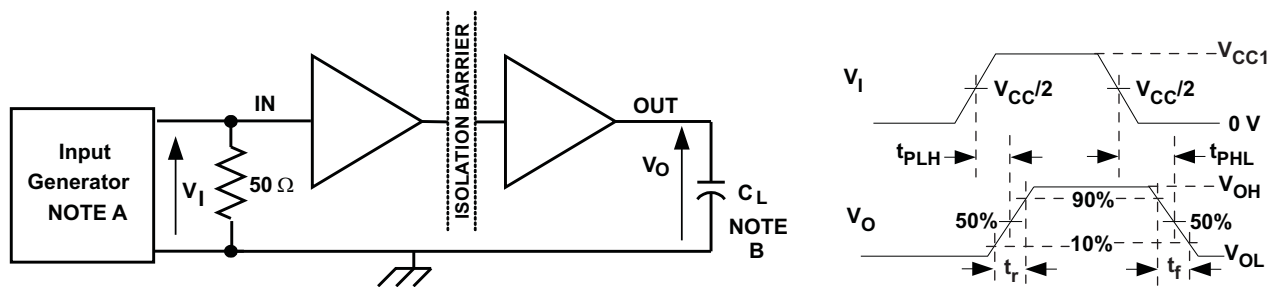

- A. The input pulse is supplied by a generator having the following characteristics: PRR ≤ 50 kHz, 50% duty cycle, $t_r \leq 3$ ns, $t_f \leq 3$ ns, $Z_O = 50 \Omega$. At the input, 50Ω resistor is required to terminate Input Generator signal. It is not needed in actual application.
- B. $C_L = 15$ pF and includes instrumentation and fixture capacitance within $\pm 20\%$.

Figure 1. Switching Characteristics Test Circuit and Voltage Waveforms

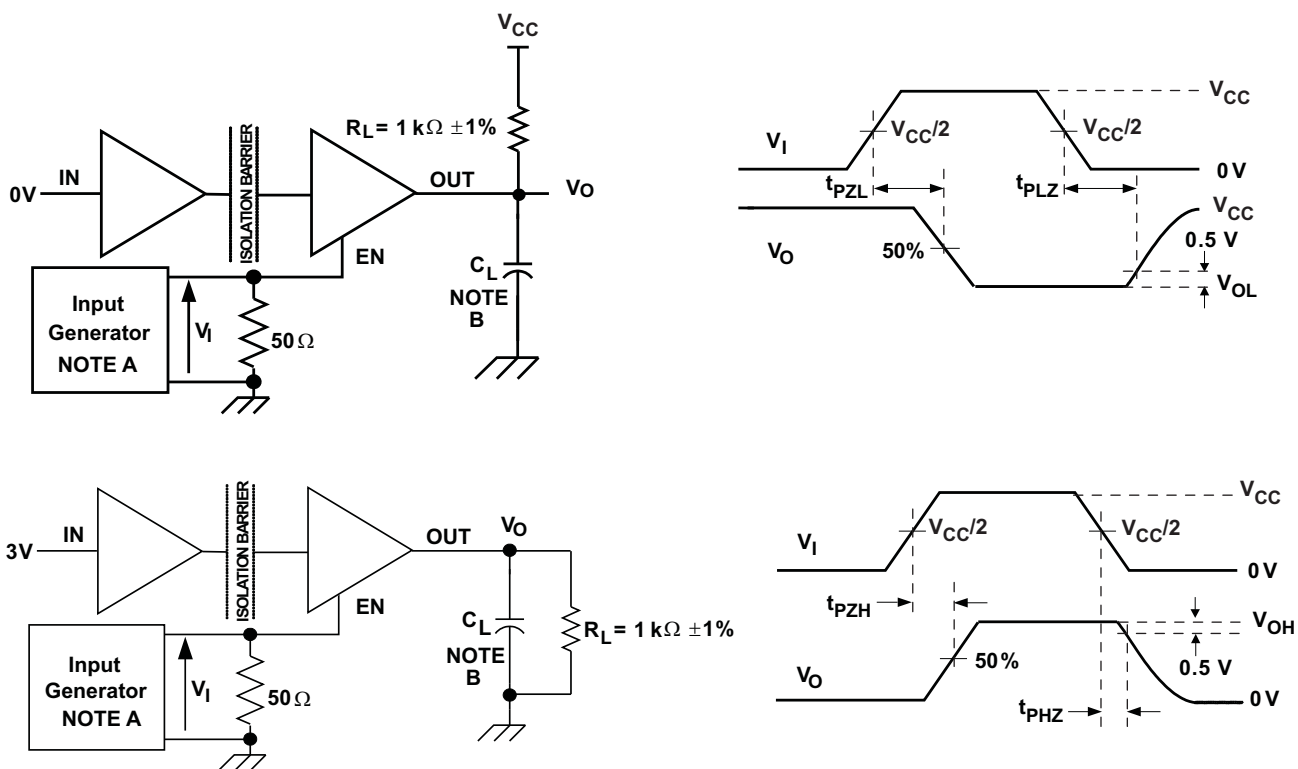

- A. The input pulse is supplied by a generator having the following characteristics: PRR ≤ 10 kHz, 50% duty cycle, $t_r \leq 3$ ns, $t_f \leq 3$ ns, $Z_O = 50 \Omega$.
- B. $C_L = 15$ pF and includes instrumentation and fixture capacitance within $\pm 20\%$.

Figure 2. Enable/Disable Propagation Delay Time Test Circuit and Waveform

PARAMETER MEASUREMENT INFORMATION (continued)

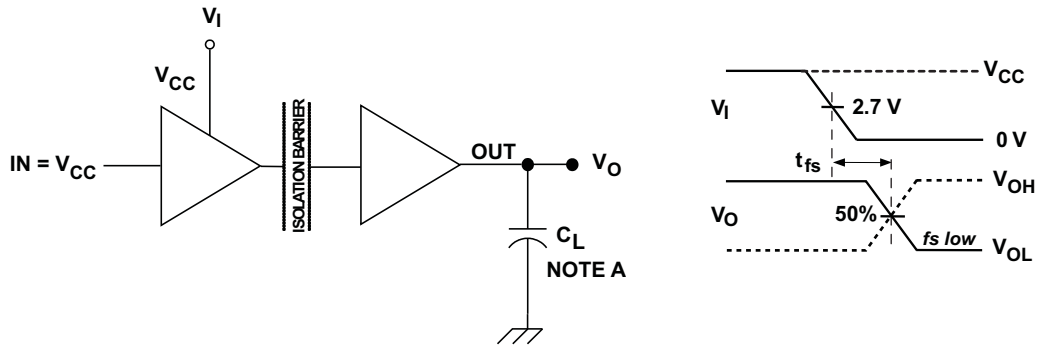

- A. $C_L = 15 \text{ pF}$ and includes instrumentation and fixture capacitance within $\pm 20\%$.

Figure 3. Failsafe Delay Time Test Circuit and Voltage Waveforms

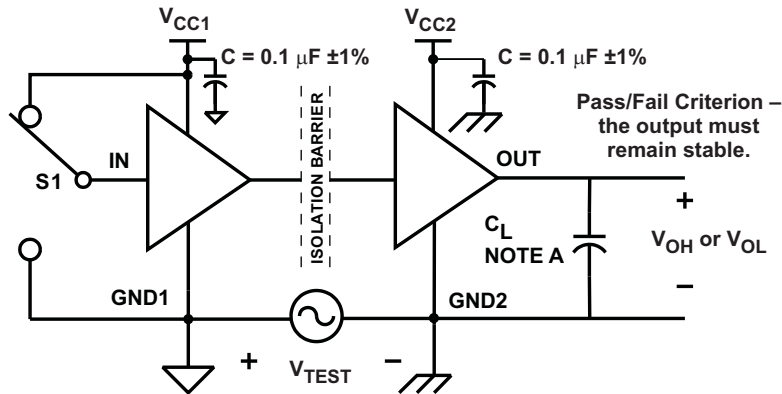

- A. $C_L = 15 \text{ pF}$ and includes instrumentation and fixture capacitance within $\pm 20\%$.

Figure 4. Common-Mode Transient Immunity Test Circuit

DEVICE INFORMATION
IEC INSULATION AND SAFETY-RELATED SPECIFICATIONS FOR DW-16 PACKAGE

PARAMETER		TEST CONDITIONS	MIN	TYP	MAX	UNIT
L(I01)	Minimum air gap (Clearance)	Shortest terminal to terminal distance through air	8.3			mm
L(I02) ⁽¹⁾	Minimum external tracking (Creepage)	Shortest terminal to terminal distance across the package surface	8.1			mm
CTI	Tracking resistance (Comparative Tracking Index)	DIN IEC 60112 / VDE 0303 Part 1	≥400			V
	Minimum Internal Gap (Internal Clearance)	Distance through the insulation	0.014			mm
R _{IO} ⁽²⁾	Isolation resistance, Input to Output	V _{IO} = 500 V, T _A < 100°C		>10 ¹²		Ω
		V _{IO} = 500 V, 100°C ≤ T _A ≤ max		>10 ¹¹		
C _{IO} ⁽²⁾	Barrier capacitance, Input to Output	V _I = 0.4 sin(2πft), f = 1MHz		2		pF
C _I ⁽³⁾	Input capacitance	V _I = V _{CC} /2 + 0.4 sin(2πft), f = 1MHz, V _{CC} = 5 V		2		pF

- (1) Per JEDEC package dimensions.
(2) All pins on each side of the barrier tied together creating a two-terminal device.
(3) Measured from input pin to ground.

NOTE

Creepage and clearance requirements should be applied according to the specific equipment isolation standards of an application. Care should be taken to maintain the creepage and clearance distance of a board design to ensure that the mounting pads of the isolator on the printed circuit board do not reduce this distance.

Creepage and clearance on a printed circuit board become equal according to the measurement techniques shown in the Isolation Glossary. Techniques such as inserting grooves and/or ribs on a printed circuit board are used to help increase these specifications.

**Table 2. DIN EN 60747-5-2 (VDE 0884 TEIL 2) INSULATION CHARACTERISTICS⁽¹⁾
over recommended operating conditions (unless otherwise noted)**

PARAMETER		TEST CONDITIONS	SPECIFICATION	UNIT
V _{IORM}	Maximum working insulation voltage ⁽²⁾		1414	V _{PEAK}
V _{PR}	Input-to-output test voltage	After Input/Output safety test subgroup 2/3, V _{PR} = V _{IORM} × 1.2, t = 10 s, Partial discharge < 5 pC	1697	V _{PEAK}
		Method a, After environmental tests subgroup 1, V _{PR} = V _{IORM} × 1.6, t = 10 s, Partial Discharge < 5 pC	2262	
		Method b1, 100% Production test V _{PR} = V _{IORM} × 1.875, t = 1 s Partial discharge < 5 pC	2652	
V _{IOTM}	Maximum transient overvoltage	V _{TEST} = V _{IOTM} t = 60 sec (Qualification) t = 1 sec (100% Production)	6000	V _{PEAK}
R _S	Insulation resistance	V _{IO} = 500 V at T _S	>10 ⁹	Ω
	Pollution degree		2	

- (1) Climatic Classification 40/125/21
(2) For applications that require DC working voltages between GND1 and GND2, please contact Texas Instruments for further details.

Table 3. IEC 60664-1 RATINGS TABLE

PARAMETER	TEST CONDITIONS	SPECIFICATION
Basic Isolation Group	Material Group	II
Installation classification	Rated mains voltage $\leq 300 V_{RMS}$	I–IV
	Rated mains voltage $\leq 600 V_{RMS}$	I–III
	Rated mains voltage $\leq 1000 V_{RMS}$	I–II

REGULATORY INFORMATION

VDE	TUV	CSA	UL
Certified according to DIN EN 60747-5-2	Certified according to EN/UL/CSA 60950-1 and 61010-1	Approved under CSA Component Acceptance Notice #5A	Recognized under 1577 Component Recognition Program
Basic Insulation Maximum Transient Overvoltage, $6000 V_{PK}$ Maximum Working Voltage, $1414 V_{PK}$	$5000 V_{RMS}$ Reinforced Insulation, $400 V_{RMS}$ maximum working voltage $5000 V_{RMS}$ Basic Insulation, $600 V_{RMS}$ maximum working voltage	$5000 V_{RMS}$ Reinforced Insulation 2 Means of Patient Protection at $125 V_{RMS}$ per IEC 60601-1 (3rd Ed.)	Single Protection, $4243 V_{RMS}^{(1)}$
File Number: 40016131	Certificate Number: U8V 11 08 77311 005	File Number: 220991	File Number: E181974

(1) Production tested $\geq 5092 V_{RMS}$ for 1 second in accordance with UL 1577.

IEC SAFETY LIMITING VALUES

Safety limiting intends to prevent potential damage to the isolation barrier upon failure of input or output circuitry. A failure of the IO can allow low resistance to ground or the supply and, without current limiting, dissipate sufficient power to overheat the die and damage the isolation barrier potentially leading to secondary system failures.

PARAMETER	TEST CONDITIONS			MIN	TYP	MAX	UNIT	
I_S Safety input, output, or supply current	DW-16	$\theta_{JA} = 72 \text{ }^\circ\text{C/W}$, $V_I = 5.5\text{V}$, $T_J = 150^\circ\text{C}$, $T_A = 25^\circ\text{C}$					316	mA
		$\theta_{JA} = 72 \text{ }^\circ\text{C/W}$, $V_I = 3.6\text{V}$, $T_J = 150^\circ\text{C}$, $T_A = 25^\circ\text{C}$					482	
		$\theta_{JA} = 72 \text{ }^\circ\text{C/W}$, $V_I = 2.7\text{V}$, $T_J = 150^\circ\text{C}$, $T_A = 25^\circ\text{C}$					643	
T_S Maximum case temperature						150	$^\circ\text{C}$	

The safety-limiting constraint is the absolute maximum junction temperature specified in the absolute maximum ratings table. The power dissipation and junction-to-air thermal impedance of the device installed in the application hardware determines the junction temperature. The assumed junction-to-air thermal resistance in the *Thermal Information* table is that of a device installed on a High-K Test Board for Leaded Surface Mount Packages. The power is the recommended maximum input voltage times the current. The junction temperature is then the ambient temperature plus the power times the junction-to-air thermal resistance.

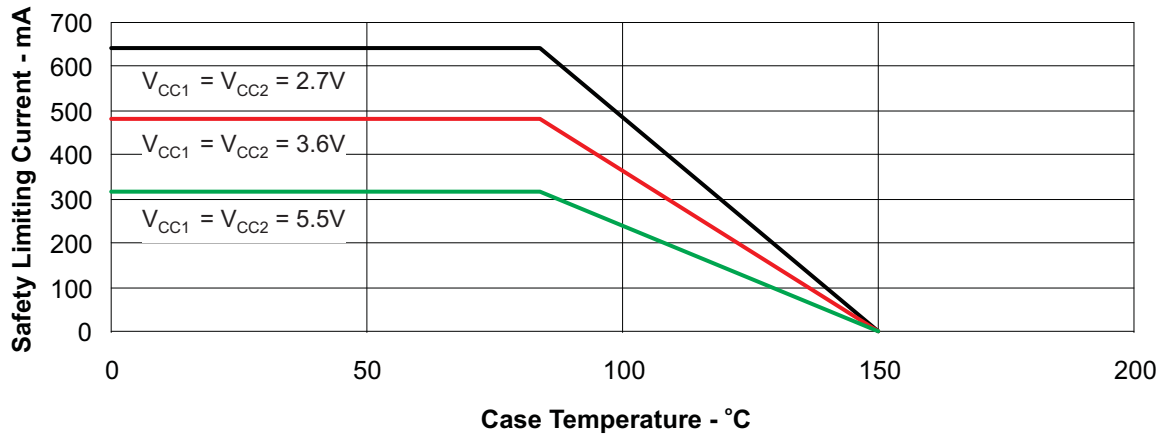

Figure 5. DW-16 θ_{JC} Thermal Derating Curve per IEC 60747-5-2

APPLICATION INFORMATION

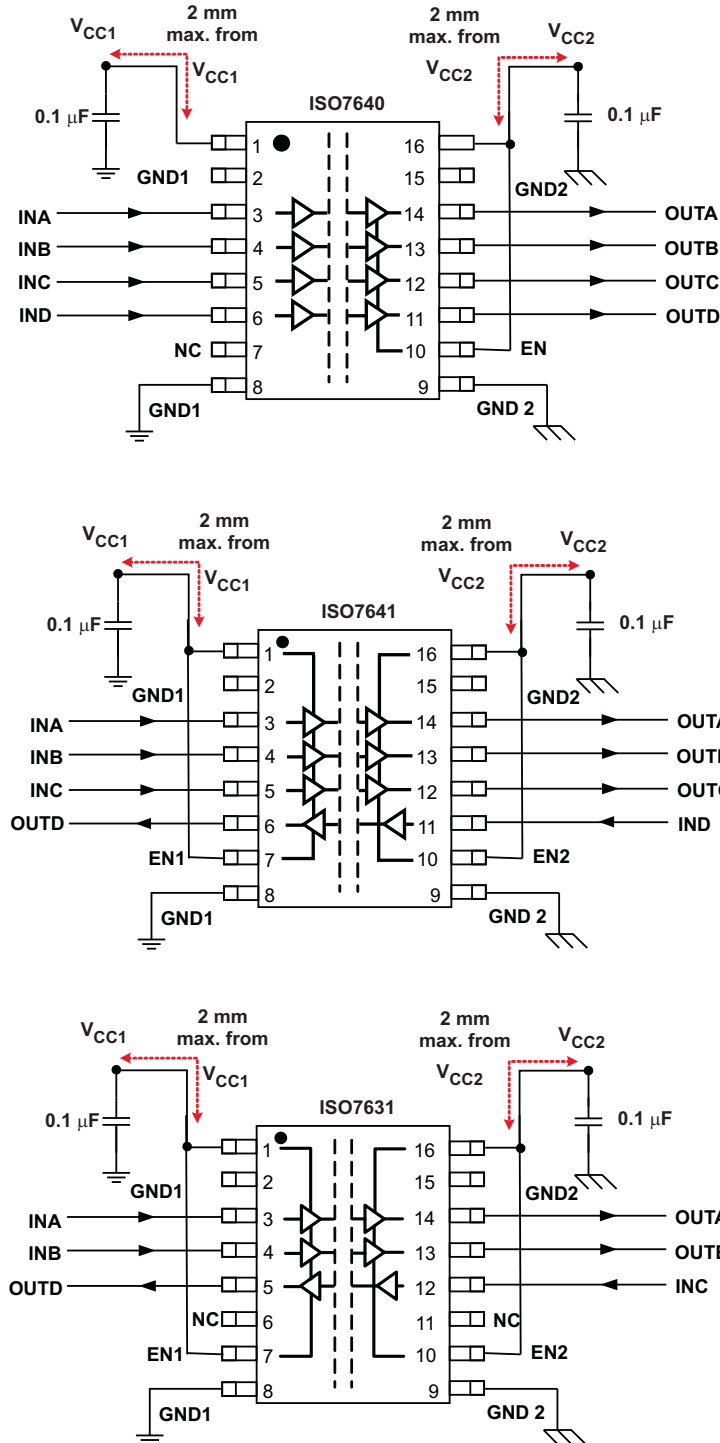

Figure 6. Typical ISO7640, ISO7641 and ISO7631 Application Circuit

Note: For detailed layout recommendations, see Application Note [SLLA284](#), *Digital Isolator Design Guide*.

TYPICAL SUPPLY CURRENT EQUATIONS

(Calculated based on room temperature and typical Silicon process)

ISO7631FM:

$$\text{At } V_{CC1} = V_{CC2} = 3.3V$$

$$I_{CC1} = 1.8072 + 0.0244 \times f + 0.0016 \times f \times C_L$$

$$I_{CC2} = 2.4625 + 0.0252 \times f + 0.0033 \times f \times C_L$$

$$\text{At } V_{CC1} = V_{CC2} = 5V$$

$$I_{CC1} = 2.3183 + 0.04 \times f + 0.0025 \times f \times C_L$$

$$I_{CC2} = 3.2582 + 0.0403 \times f + 0.0049 \times f \times C_L$$

ISO7640FM:

$$\text{At } V_{CC1} = V_{CC2} = 3.3V$$

$$I_{CC1} = 0.388 + 0.0312 \times f$$

$$I_{CC2} = 3.39 + 0.03561 \times f + 0.006588 \times f \times C_L$$

$$\text{At } V_{CC1} = V_{CC2} = 5V$$

$$I_{CC1} = 0.584 + 0.05349 \times f$$

$$I_{CC2} = 4.184 + 0.05597 \times f + 0.009771 \times f \times C_L$$

ISO7641FM:

$$\text{At } V_{CC1} = V_{CC2} = 3.3V$$

$$I_{CC1} = 1.848 + 0.03233 \times f + 0.001645 \times f \times C_L$$

$$I_{CC2} = 3.005 + 0.03459 \times f + 0.0049395 \times f \times C_L$$

$$\text{At } V_{CC1} = V_{CC2} = 5V$$

$$I_{CC1} = 2.369 + 0.05385 \times f + 0.002448 \times f \times C_L$$

$$I_{CC2} = 3.857 + 0.05506 \times f + 0.007348 \times f \times C_L$$

ISO7631FC:

$$\text{At } V_{CC1} = V_{CC2} = 3.3V$$

$$I_{CC1} = 1.1762 + 0.0325 \times f + 0.0017 \times f \times C_L$$

$$I_{CC2} = 1.5285 + 0.0299 \times f + 0.0033 \times f \times C_L$$

$$\text{At } V_{CC1} = V_{CC2} = 5V$$

$$I_{CC1} = 1.6001 + 0.0528 \times f + 0.0025 \times f \times C_L$$

$$I_{CC2} = 2.2032 + 0.0475 \times f + 0.005 \times f \times C_L$$

ISO7640FC:

$$\text{At } V_{CC1} = V_{CC2} = 3.3V$$

$$I_{CC1} = 0.3209 + 0.0488 \times f$$

$$I_{CC2} = 1.9699 + 0.0385 \times f + 0.0066 \times f \times C_L$$

$$\text{At } V_{CC1} = V_{CC2} = 5V$$

$$I_{CC1} = 0.5038 + 0.0812 \times f$$

$$I_{CC2} = 2.6117 + 0.0603 \times f + 0.0101 \times f \times C_L$$

ISO7641FC:

$$\text{At } V_{CC1} = V_{CC2} = 3.3V$$

$$I_{CC1} = 1.2162 + 0.0462 \times f + 0.0017 \times f \times C_L$$

$$I_{CC2} = 1.8054 + 0.0411 \times f + 0.005 \times f \times C_L$$

$$\text{At } V_{CC1} = V_{CC2} = 5V$$

$$I_{CC1} = 1.6583 + 0.0757 \times f + 0.0025 \times f \times C_L$$

$$I_{CC2} = 2.5008 + 0.0655 \times f + 0.0076 \times f \times C_L$$

I_{CC1} and I_{CC2} are typical supply currents measured in mA; f is data rate measured in Mbps; C_L is the capacitive load on each channel measured in pF.

(Calculated based on room temperature and typical Silicon process)

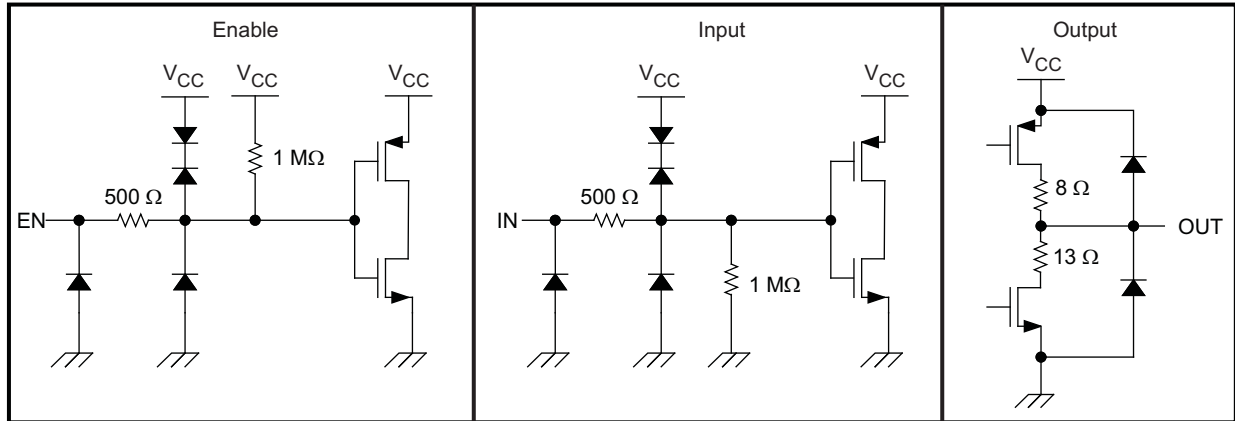

Figure 7. Device I/O Schematics

TYPICAL CHARACTERISTICS

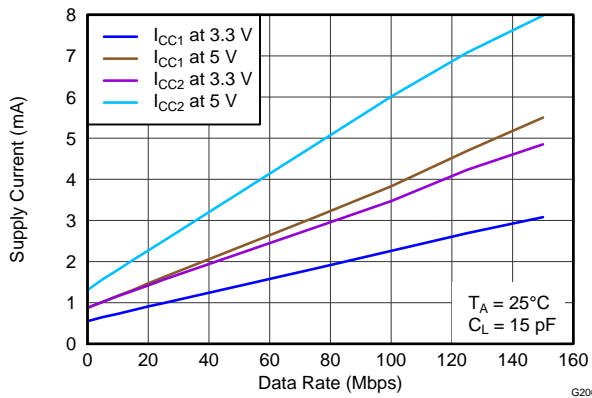

Figure 8. ISO7631FM Supply Current Per Channel vs Data Rate

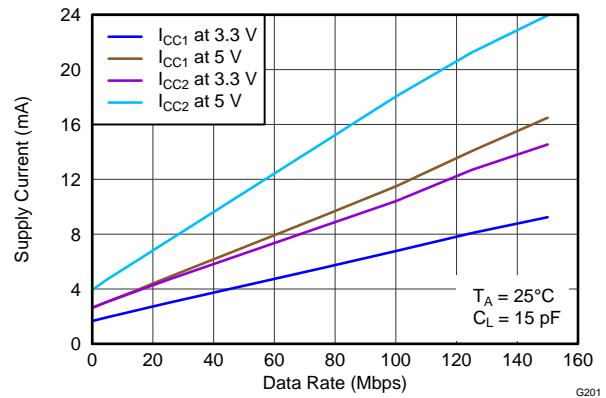

Figure 9. ISO7631FM Supply Current For All Channels vs Data Rate

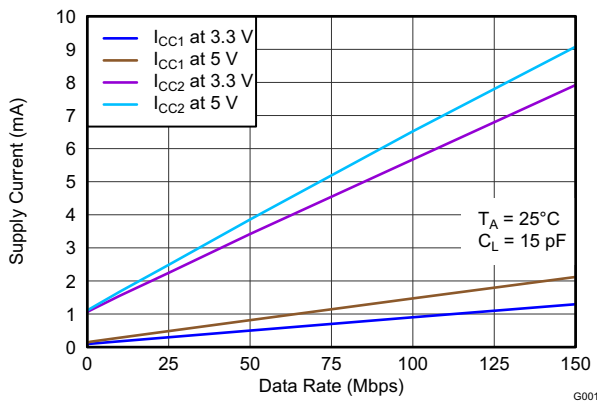

Figure 10. ISO7640FM Supply Current Per Channel vs Data Rate

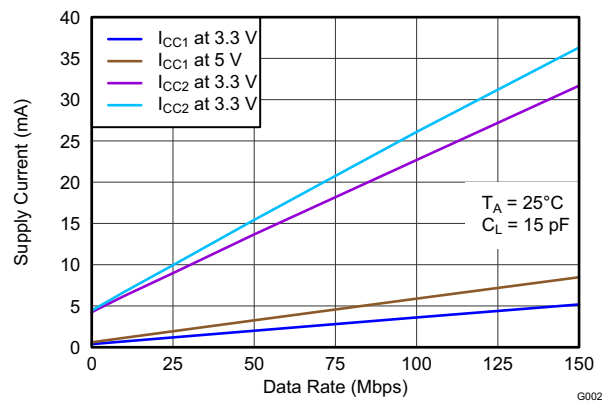

Figure 11. ISO7640FM Supply Current For All Channels vs Data Rate

TYPICAL CHARACTERISTICS (continued)

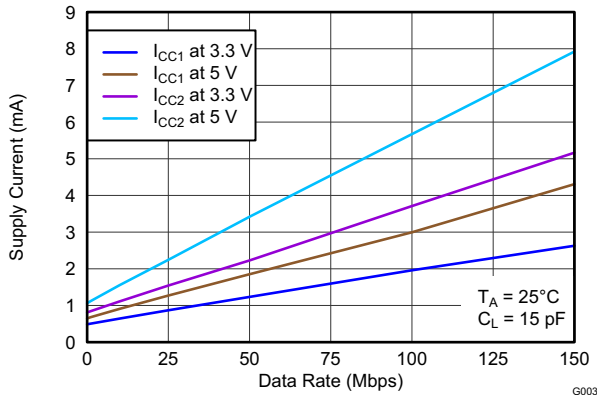

Figure 12. ISO7641FM Supply Current Per Channel vs Data Rate

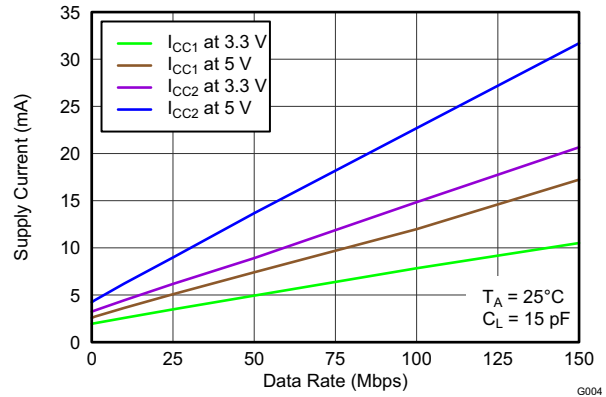

Figure 13. ISO7641FM Supply Current For All Channels vs Data Rate

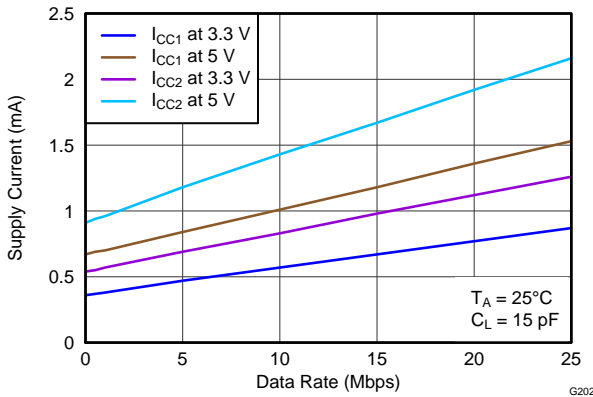

Figure 14. ISO7631FC Supply Current Per Channel vs Data Rate

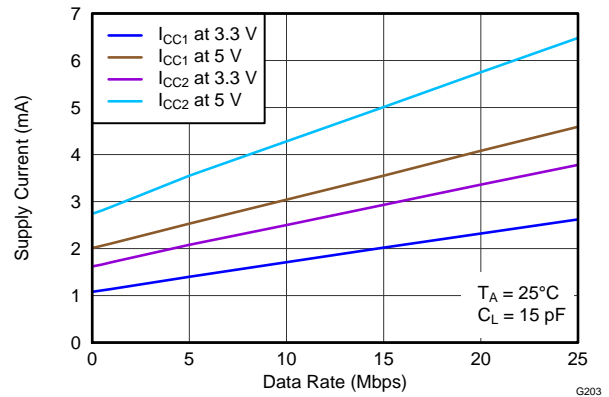

Figure 15. ISO7631FC Supply Current For All Channels vs Data Rate

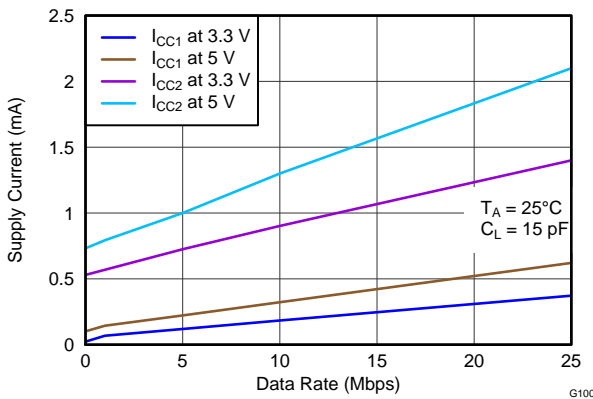

Figure 16. ISO7640FC Supply Current Per Channel vs Data Rate

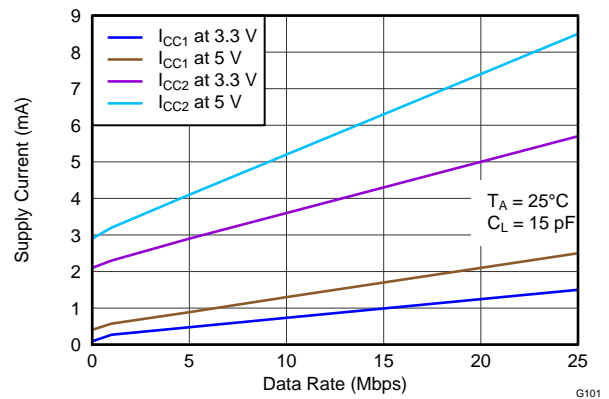

Figure 17. ISO7640FC Supply Current For All Channels vs Data Rate

TYPICAL CHARACTERISTICS (continued)

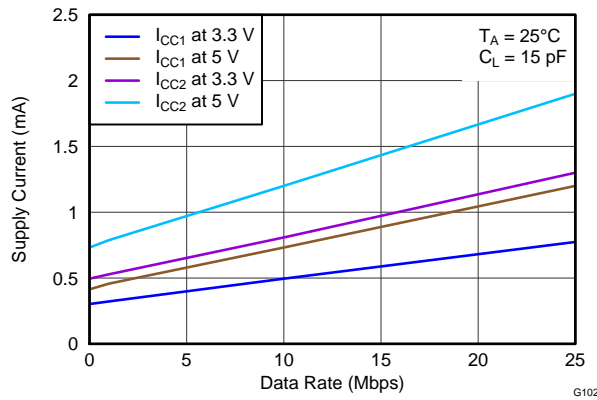

Figure 18. ISO7641FC Supply Current Per Channel vs Data Rate

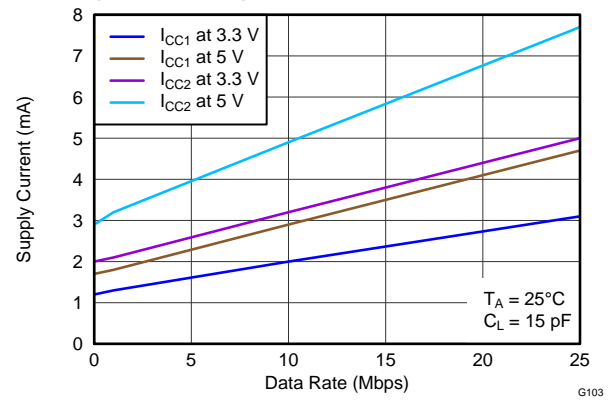

Figure 19. ISO7641FC Supply Current For All Channels vs Data Rate

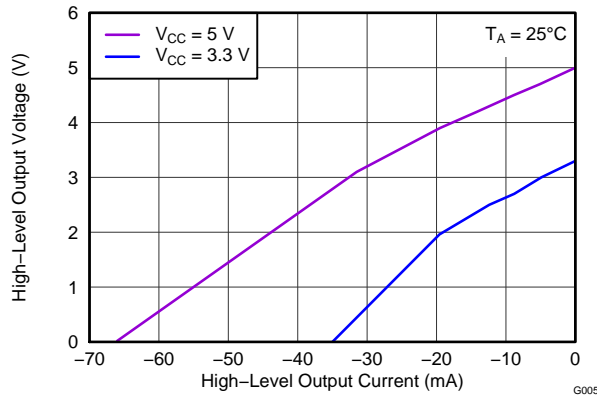

Figure 20. M-Grade High-Level Output Voltage vs High-Level Output Current

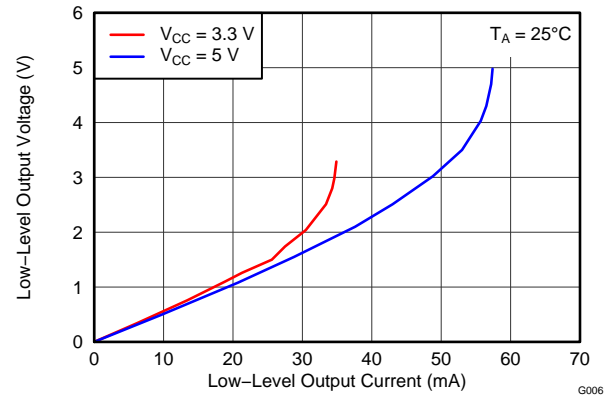

Figure 21. M-Grade Low-Level Output Voltage vs Low-Level Output Current

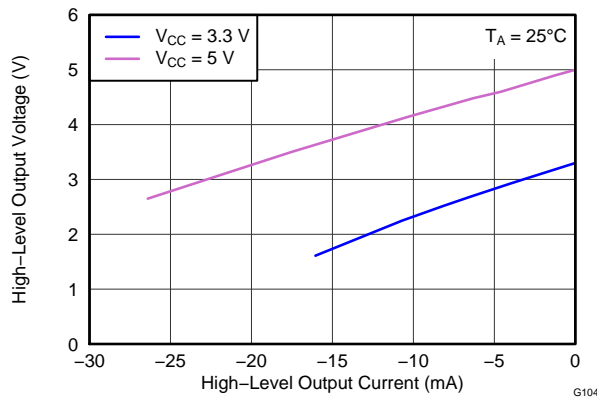

Figure 22. C-Grade High-Level Output Voltage vs High-Level Output Current

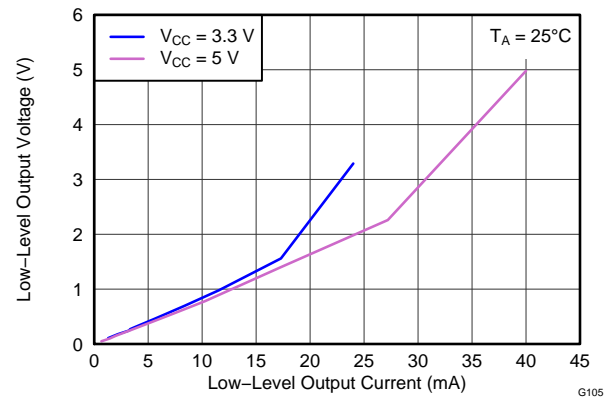

Figure 23. C-Grade Low-Level Output Voltage vs Low-Level Output Current

TYPICAL CHARACTERISTICS (continued)

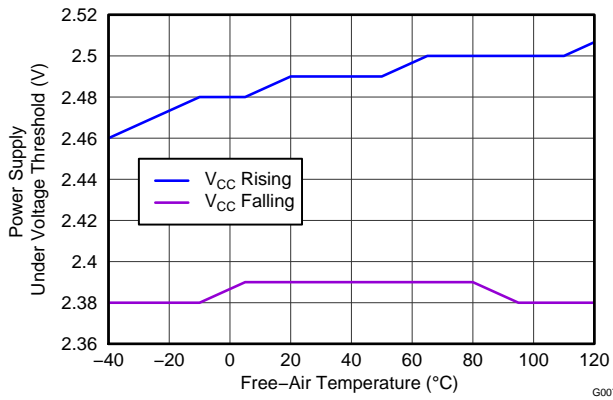

Figure 24. V_{CC} Undervoltage Threshold vs Free Air Temperature

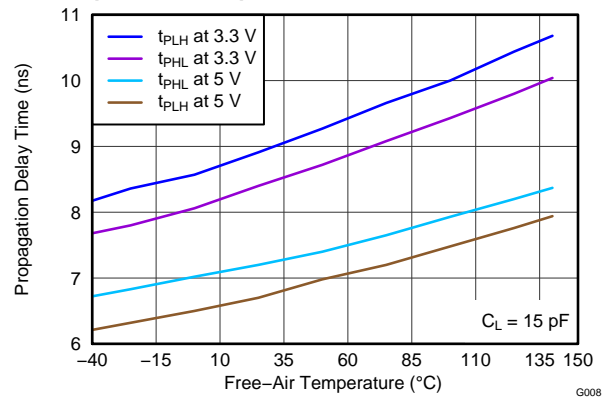

Figure 25. M-Grade Propagation Delay Time vs Free Air Temperature

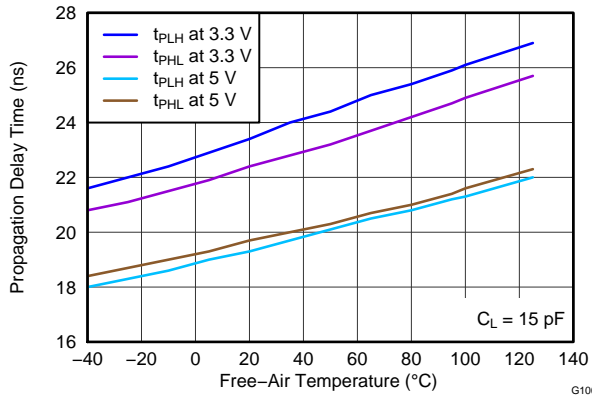

Figure 26. C-Grade Propagation Delay Time vs Free Air Temperature

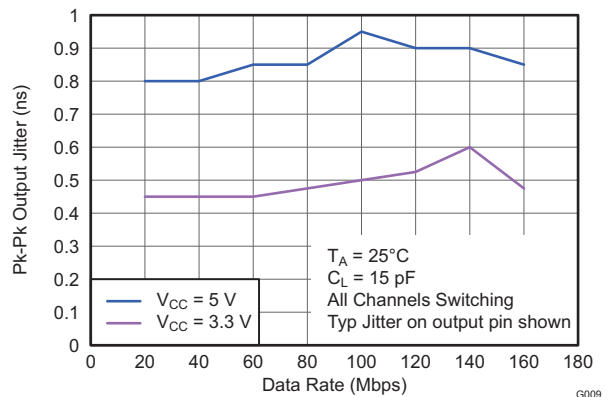

Figure 27. M-Grade Output Jitter vs Data Rate

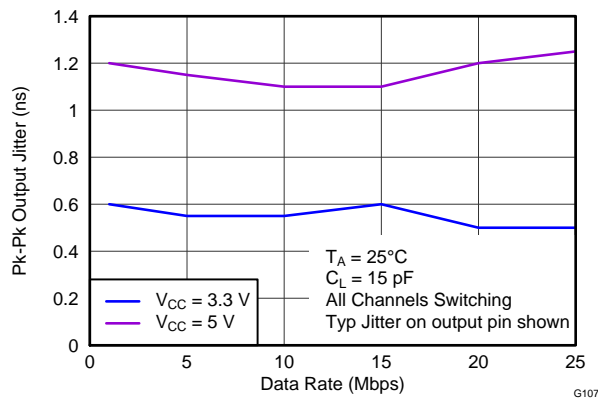

Figure 28. C-Grade Output Jitter vs Data Rate

TYPICAL CHARACTERISTICS (continued)

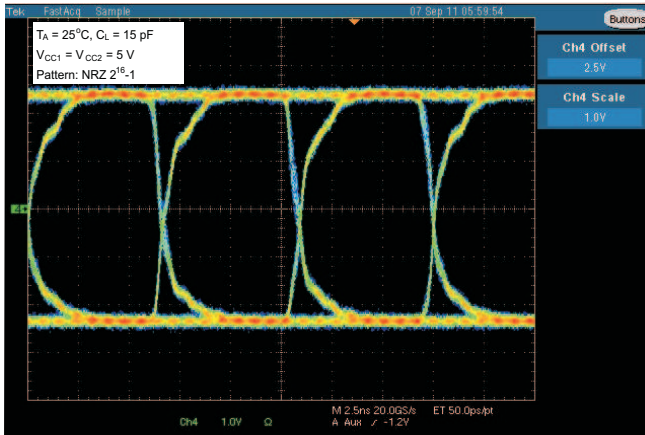

Figure 29. M-Grade Typical Eye Diagram at 150 Mbps, 5 V Operation

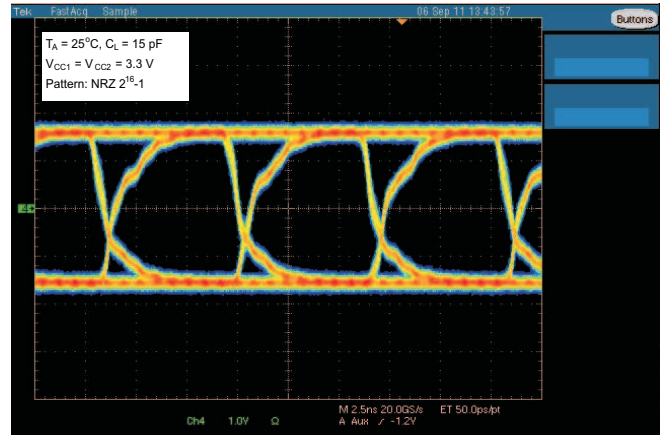

Figure 30. M-Grade Typical Eye Diagram at 150 Mbps, 3.3 V Operation

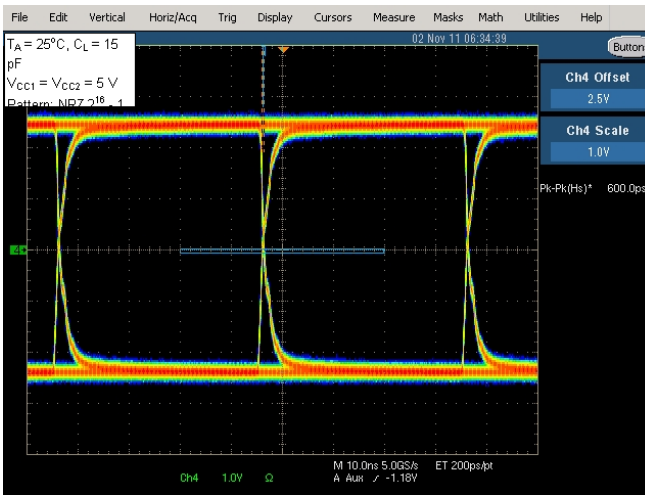

Figure 31. C-Grade Typical Eye Diagram at 25 Mbps, 5 V Operation

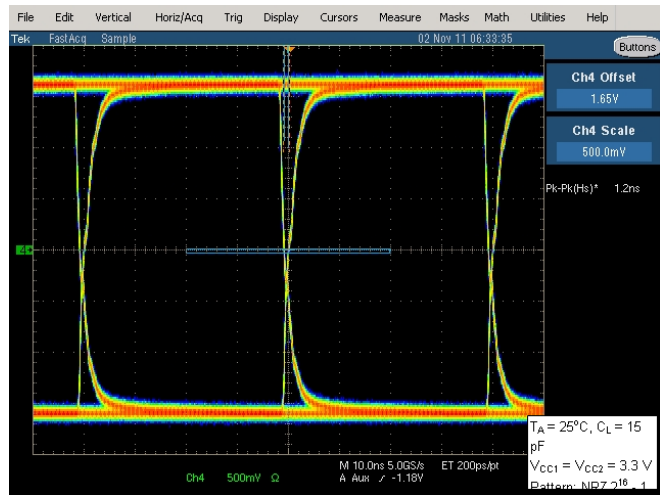

Figure 32. C-Grade Typical Eye Diagram at 25 Mbps, 3.3 V Operation

REVISION HISTORY

Changes from Original (September 2011) to Revision A	Page
• Changed Figure 3 - From: 0 V or V_{CC} To: $I_N = V_{CC}$	16
• Added Note (1) "Per JEDEC package dimensions" to the IEC INSULATION AND SAFETY-RELATED SPECIFICATIONS FOR DW-16 PACKAGE table	17
• Changed L(I01) Min Value From: 8 mm To: 8.3 mm	17
• Changed L(I02) Min Value From: 7.8 mm To: 8.1 mm	17
• Added pinout for ISO7641 and ISO7631 to Figure 6	20

Changes from Revision A (October 2011) to Revision B	Page
• Changed feature bullet From: ISO7641FC: 1.2 mA at 10 Mbps To: ISO7641FC: 1.3 mA at 10 Mbps	1
• Changed Safety and Regulatory Approvals bullet From: 6 KV_{PK} for 1 Minute per UL1577 and VDE (Pending) To: 6000 V_{PK} / 4243 V_{RMS} for 1 Minute per UL 1577 (pending)	1
• Changed Safety and Regulatory Approvals bullet From: To: 6000 V_{PK} / 4243 V_{RMS} for 1 Minute per UL 1577 (approved)	1
• Changed Safety and Regulatory Approvals bullet From: CSA Component Acceptance Notice 5A, IEC 60601-1 Medical Standard (pending) To: CSA Component Acceptance Notice 5A, IEC 60601-1 Medical Standard (approved)	1
• ISO7640FC - Removed Product Preview status	3
• ISO7641FC - Removed Product Preview status	3
• Changed all the ELECTRICAL CHARACTERISTICS tables	5
• Changed all the SWITCHING CHARACTERISTICS tables	5
• Changed the SWITCHING CHARACTERISTICS table ISO7640F and ISO7641F C-Grade values	6
• Changed the SWITCHING CHARACTERISTICS table ISO7640F and ISO7641F C-Grade values	8
• Changed the SWITCHING CHARACTERISTICS table ISO7640F and ISO7641F C-Grade values	10
• Changed the SWITCHING CHARACTERISTICS table ISO7640F and ISO7641F C-Grade values	12
• Changed the SWITCHING CHARACTERISTICS table ISO7640F and ISO7641F C-Grade values	14
• Changed the IEC 60664-1 Ratings Table	18

Changes from Revision B (December 2011) to Revision C	Page
• Changed Safety and Regulatory Approvals bullet From: 6000 V_{PK} / 4243 V_{RMS} for 1 Minute per UL1577 (pending) To: 6000 V_{PK} / 4243 V_{RMS} for 1 Minute per UL 1577 (approved)	1
• Changed Description text From: The devices have TTL input thresholds and can operate from 2.7 V, 3.3 V and 5 V supplies. To: The devices have TTL input thresholds and can operate from 2.7 V (M-Grade), 3.3 V and 5 V supplies.	2
• Deleted the Product Preview Note From the Available Options Table	3
• Changed the ESD standards	4
• Changed UL in the REGULATORY INFORMATION Table From: File Number: E181974 (Approval Pending) To: File Number: E181974	18
• Changed the typical characteristics section	22

PACKAGING INFORMATION

Orderable Device	Status ⁽¹⁾	Package Type	Package Drawing	Pins	Package Qty	Eco Plan ⁽²⁾	Lead/ Ball Finish	MSL Peak Temp ⁽³⁾	Samples (Requires Login)
ISO7640FMDW	ACTIVE	SOIC	DW	16	40	Green (RoHS & no Sb/Br)	CU NIPDAU	Level-3-260C-168 HR	
ISO7640FMDWR	ACTIVE	SOIC	DW	16	2000	Green (RoHS & no Sb/Br)	CU NIPDAU	Level-3-260C-168 HR	
ISO7641FMDW	ACTIVE	SOIC	DW	16	40	Green (RoHS & no Sb/Br)	CU NIPDAU	Level-3-260C-168 HR	
ISO7641FMDWR	ACTIVE	SOIC	DW	16	2000	Green (RoHS & no Sb/Br)	CU NIPDAU	Level-3-260C-168 HR	

⁽¹⁾ The marketing status values are defined as follows:

ACTIVE: Product device recommended for new designs.

LIFEBUY: TI has announced that the device will be discontinued, and a lifetime-buy period is in effect.

NRND: Not recommended for new designs. Device is in production to support existing customers, but TI does not recommend using this part in a new design.

PREVIEW: Device has been announced but is not in production. Samples may or may not be available.

OBSOLETE: TI has discontinued the production of the device.

⁽²⁾ Eco Plan - The planned eco-friendly classification: Pb-Free (RoHS), Pb-Free (RoHS Exempt), or Green (RoHS & no Sb/Br) - please check <http://www.ti.com/productcontent> for the latest availability information and additional product content details.

TBD: The Pb-Free/Green conversion plan has not been defined.

Pb-Free (RoHS): TI's terms "Lead-Free" or "Pb-Free" mean semiconductor products that are compatible with the current RoHS requirements for all 6 substances, including the requirement that lead not exceed 0.1% by weight in homogeneous materials. Where designed to be soldered at high temperatures, TI Pb-Free products are suitable for use in specified lead-free processes.

Pb-Free (RoHS Exempt): This component has a RoHS exemption for either 1) lead-based flip-chip solder bumps used between the die and package, or 2) lead-based die adhesive used between the die and leadframe. The component is otherwise considered Pb-Free (RoHS compatible) as defined above.

Green (RoHS & no Sb/Br): TI defines "Green" to mean Pb-Free (RoHS compatible), and free of Bromine (Br) and Antimony (Sb) based flame retardants (Br or Sb do not exceed 0.1% by weight in homogeneous material)

⁽³⁾ MSL, Peak Temp. -- The Moisture Sensitivity Level rating according to the JEDEC industry standard classifications, and peak solder temperature.

Important Information and Disclaimer: The information provided on this page represents TI's knowledge and belief as of the date that it is provided. TI bases its knowledge and belief on information provided by third parties, and makes no representation or warranty as to the accuracy of such information. Efforts are underway to better integrate information from third parties. TI has taken and continues to take reasonable steps to provide representative and accurate information but may not have conducted destructive testing or chemical analysis on incoming materials and chemicals. TI and TI suppliers consider certain information to be proprietary, and thus CAS numbers and other limited information may not be available for release.

In no event shall TI's liability arising out of such information exceed the total purchase price of the TI part(s) at issue in this document sold by TI to Customer on an annual basis.

TAPE AND REEL INFORMATION
REEL DIMENSIONS

TAPE DIMENSIONS

A0	Dimension designed to accommodate the component width
B0	Dimension designed to accommodate the component length
K0	Dimension designed to accommodate the component thickness
W	Overall width of the carrier tape
P1	Pitch between successive cavity centers

TAPE AND REEL INFORMATION

*All dimensions are nominal

Device	Package Type	Package Drawing	Pins	SPQ	Reel Diameter (mm)	Reel Width W1 (mm)	A0 (mm)	B0 (mm)	K0 (mm)	P1 (mm)	W (mm)	Pin1 Quadrant
ISO7640FMDWR	SOIC	DW	16	2000	330.0	16.4	10.75	10.7	2.7	12.0	16.0	Q1

TAPE AND REEL BOX DIMENSIONS



*All dimensions are nominal

Device	Package Type	Package Drawing	Pins	SPQ	Length (mm)	Width (mm)	Height (mm)
ISO7640FMDWR	SOIC	DW	16	2000	346.0	346.0	33.0

DW (R-PDSO-G16)

PLASTIC SMALL OUTLINE



- NOTES:
- A. All linear dimensions are in inches (millimeters). Dimensioning and tolerancing per ASME Y14.5M-1994.
 - B. This drawing is subject to change without notice.
 - C. Body dimensions do not include mold flash or protrusion not to exceed 0.006 (0,15).
 - D. Falls within JEDEC MS-013 variation AA.

DW (R-PDSO-G16)

PLASTIC SMALL OUTLINE

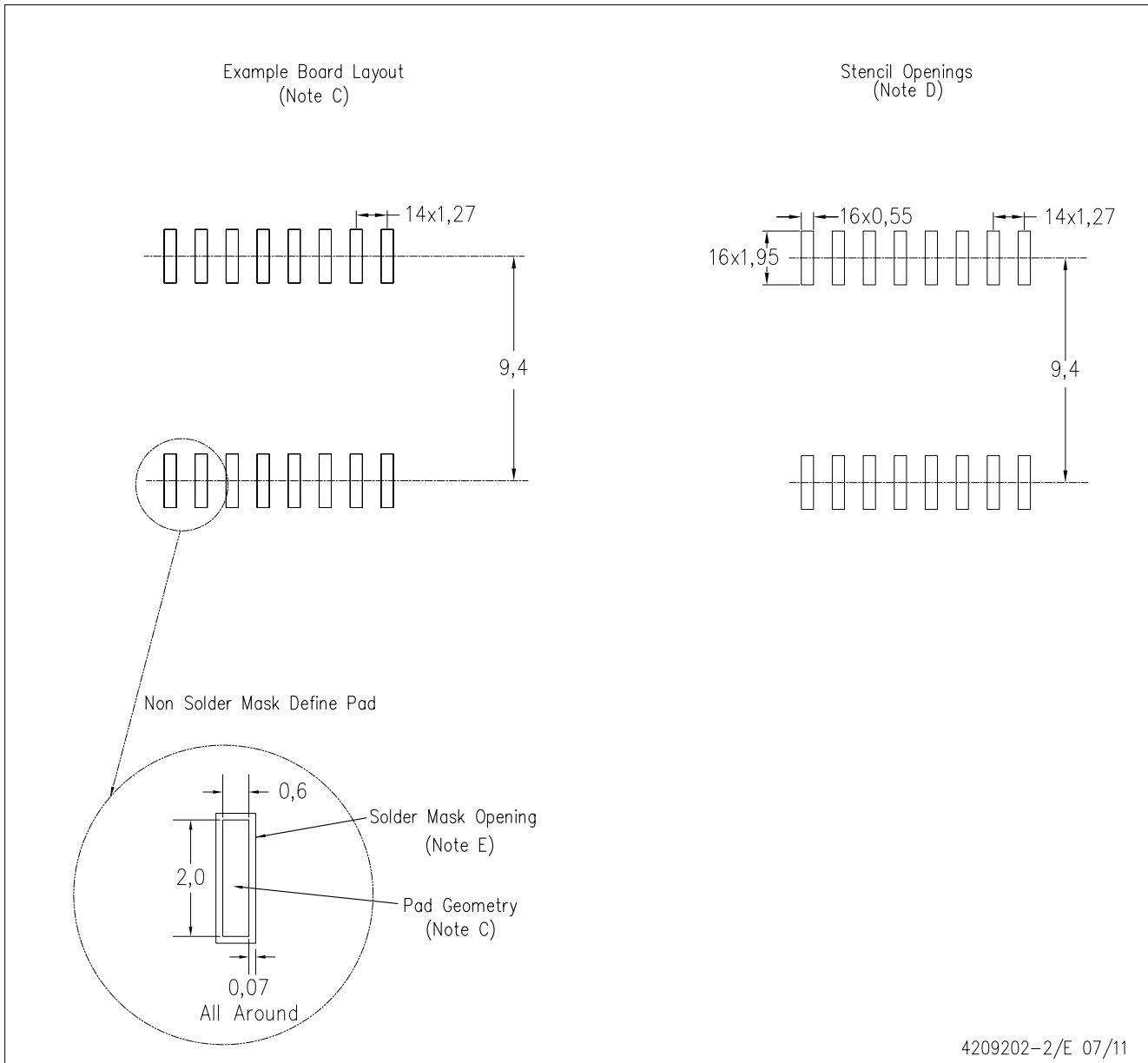

4209202-2/E 07/11

- NOTES:
- A. All linear dimensions are in millimeters.
 - B. This drawing is subject to change without notice.
 - C. Refer to IPC7351 for alternate board design.
 - D. Laser cutting apertures with trapezoidal walls and also rounding corners will offer better paste release. Customers should contact their board assembly site for stencil design recommendations. Refer to IPC-7525
 - E. Customers should contact their board fabrication site for solder mask tolerances between and around signal pads.

IMPORTANT NOTICE

Texas Instruments Incorporated and its subsidiaries (TI) reserve the right to make corrections, modifications, enhancements, improvements, and other changes to its products and services at any time and to discontinue any product or service without notice. Customers should obtain the latest relevant information before placing orders and should verify that such information is current and complete. All products are sold subject to TI's terms and conditions of sale supplied at the time of order acknowledgment.

TI warrants performance of its hardware products to the specifications applicable at the time of sale in accordance with TI's standard warranty. Testing and other quality control techniques are used to the extent TI deems necessary to support this warranty. Except where mandated by government requirements, testing of all parameters of each product is not necessarily performed.

TI assumes no liability for applications assistance or customer product design. Customers are responsible for their products and applications using TI components. To minimize the risks associated with customer products and applications, customers should provide adequate design and operating safeguards.

TI does not warrant or represent that any license, either express or implied, is granted under any TI patent right, copyright, mask work right, or other TI intellectual property right relating to any combination, machine, or process in which TI products or services are used. Information published by TI regarding third-party products or services does not constitute a license from TI to use such products or services or a warranty or endorsement thereof. Use of such information may require a license from a third party under the patents or other intellectual property of the third party, or a license from TI under the patents or other intellectual property of TI.

Reproduction of TI information in TI data books or data sheets is permissible only if reproduction is without alteration and is accompanied by all associated warranties, conditions, limitations, and notices. Reproduction of this information with alteration is an unfair and deceptive business practice. TI is not responsible or liable for such altered documentation. Information of third parties may be subject to additional restrictions.

Resale of TI products or services with statements different from or beyond the parameters stated by TI for that product or service voids all express and any implied warranties for the associated TI product or service and is an unfair and deceptive business practice. TI is not responsible or liable for any such statements.

TI products are not authorized for use in safety-critical applications (such as life support) where a failure of the TI product would reasonably be expected to cause severe personal injury or death, unless officers of the parties have executed an agreement specifically governing such use. Buyers represent that they have all necessary expertise in the safety and regulatory ramifications of their applications, and acknowledge and agree that they are solely responsible for all legal, regulatory and safety-related requirements concerning their products and any use of TI products in such safety-critical applications, notwithstanding any applications-related information or support that may be provided by TI. Further, Buyers must fully indemnify TI and its representatives against any damages arising out of the use of TI products in such safety-critical applications.

TI products are neither designed nor intended for use in military/aerospace applications or environments unless the TI products are specifically designated by TI as military-grade or "enhanced plastic." Only products designated by TI as military-grade meet military specifications. Buyers acknowledge and agree that any such use of TI products which TI has not designated as military-grade is solely at the Buyer's risk, and that they are solely responsible for compliance with all legal and regulatory requirements in connection with such use.

TI products are neither designed nor intended for use in automotive applications or environments unless the specific TI products are designated by TI as compliant with ISO/TS 16949 requirements. Buyers acknowledge and agree that, if they use any non-designated products in automotive applications, TI will not be responsible for any failure to meet such requirements.

Following are URLs where you can obtain information on other Texas Instruments products and application solutions:

Products

Audio	www.ti.com/audio
Amplifiers	amplifier.ti.com
Data Converters	dataconverter.ti.com
DLP® Products	www.dlp.com
DSP	dsp.ti.com
Clocks and Timers	www.ti.com/clocks
Interface	interface.ti.com
Logic	logic.ti.com
Power Mgmt	power.ti.com
Microcontrollers	microcontroller.ti.com
RFID	www.ti-rfid.com
OMAP Mobile Processors	www.ti.com/omap
Wireless Connectivity	www.ti.com/wirelessconnectivity

Applications

Automotive and Transportation	www.ti.com/automotive
Communications and Telecom	www.ti.com/communications
Computers and Peripherals	www.ti.com/computers
Consumer Electronics	www.ti.com/consumer-apps
Energy and Lighting	www.ti.com/energy
Industrial	www.ti.com/industrial
Medical	www.ti.com/medical
Security	www.ti.com/security
Space, Avionics and Defense	www.ti.com/space-avionics-defense
Video and Imaging	www.ti.com/video

TI E2E Community Home Page

e2e.ti.com

Mailing Address: Texas Instruments, Post Office Box 655303, Dallas, Texas 75265
Copyright © 2012, Texas Instruments Incorporated