

LMV851,LMV852,LMV854

Application Note 1760 EMIRR Evaluation Boards for LMV851/LMV852/LMV854



Literature Number: SNOA510A

EMIRR Evaluation Boards for LMV851/LMV852/ LMV854

National Semiconductor
Application Note 1760
Gerrit de Wagt
July 11, 2008



General Description

To demonstrate the EMI robustness of the LMV851/LMV852/LMV854 and to be able to measure the parameter EMIRR, three evaluation boards have been developed; one for each device. This document describes the evaluation boards and explains how to perform EMIRR measurements. Focus is on one of the input pins as those are most sensitive to EMI. Based on symmetry considerations, it can be expected that both inputs have the same EMIRR. For reasons of simplicity of the required schematic the measurement on the IN+ pin is selected. A detailed description on EMI and EMIRR for the other pins can be found in Application Note AN-1698.

To identify EMI robust op amps, a parameter is defined that quantitatively describes the EMI performance. A quantitative measure enables the comparison and the ranking of op amps on their EMI robustness. The definition of the parameter EMIRR is given by:

$$EMIRR_{V_{RF_PEAK}} = 20 \log \left(\frac{V_{RF_PEAK}}{\Delta V_{OS}} \right)$$

30046002

where V_{RF_PEAK} is the amplitude of the applied unmodulated RF signal (V) and ΔV_{OS} is the resulting input-referred offset voltage shift (V).

Op Amp Configuration

To have best defined RF levels on the pin under test, no op amp feedback elements should be in the RF signal path. Therefore, the op amp is connected in a unity-gain configuration. This yields the lowest level of RF filtering due to a feedback network. Schematics and layouts are included in this document.

Applying the RF Signal

Care needs to be taken in applying the RF signal to the pin under test. Signals up to a few GHz will be used, so the whole RF signal path needs to match the characteristic impedance of the RF generator. This requires proper coaxial cabling from the generator to the test board. On the test board a 50Ω stripline needs to be used to bring the RF signal as close as possible to the pin under test. In this case the stripline can be connected directly from the connector to the IN+ pin. A 50Ω termination at the pin under test is also required. For symmetry reasons this is done with two 100Ω resistors in parallel, one on each side of the strip line. Setting up the test environment with a 50Ω resistor close to the LMV851/LMV852/LMV854 ensures that the RF levels at the pin under test are well defined. This 50Ω resistor is also used to set the bias

level of the IN+ pin to ground level. The DC measurements are taken at the output of the op amp. Since the op amp is in the unity gain configuration, the input referred offset voltage shift corresponds one-to-one to the measured output voltage shift.

Isolating the Other Pins

When the pin under test is tested, the other pins need to be decoupled for RF signals. This ensures that the obtained offset voltage shift is dominantly a result of coupling the RF signal to the pin under test. For this decoupling standard SMD components can be used.

Layout Considerations

The layout of the evaluation board requires some attention. For decoupling the supply lines it is suggested that 10 nF capacitors be placed as close as possible to the op amp. For single supply, place a capacitor between V+ and V-. For dual supplies, place one capacitor between V+ and the board ground, and a second capacitor between ground and V-. On the LMV851 evaluation board, the decoupling of the negative pin V- is implemented by a capacitor between V+ and V-. This is done for easy routing and to keep connections to the pins short. Even with the LMV851/LMV852/LMV854's inherent hardening against EMI, it is still recommended to keep the input traces short and as far as possible from RF sources. Then the RF signals entering the chip are as low as possible, and the remaining EMI can be, almost, completely eliminated in the chip by the EMI reducing features of the LMV851/LMV852/LMV854.

Measurement Procedure

The measurement procedure is the same for all test circuits. To measure the input referred offset voltage shift needed for calculating the EMIRR, the following procedure can be used:

1. Measure V_{OUT} when the RF signal is off.
2. Measure V_{OUT} when the RF signal is on.
3. Translate measured V_{OUT} voltages to input referred voltages. Translation is one-to-one in this case since the gain is one in the IN+ test setup.
4. Subtract the two measured input referred voltages.
5. Verify if the offset shift is above the noise level of the op amp setup and the op amp is not saturated. If this is not the case choose another RF level and start the procedure again.
6. Calculate the EMIRR.
7. If needed, transform the results to an EMIRR based on a 100 mV_p RF signal.

LMV851 Evaluation Board

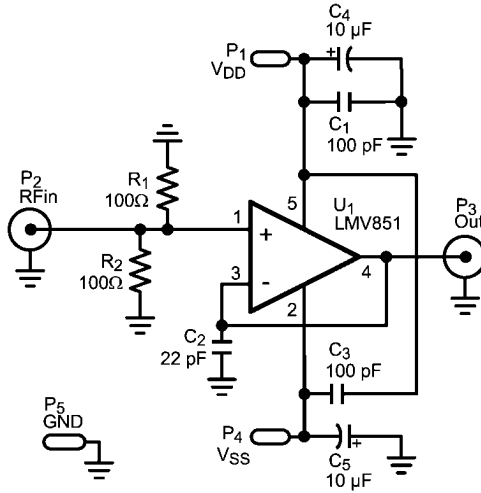

30046001

FIGURE 1. Schematic for LMV851, Coupling RF Signal to the IN+ Pin

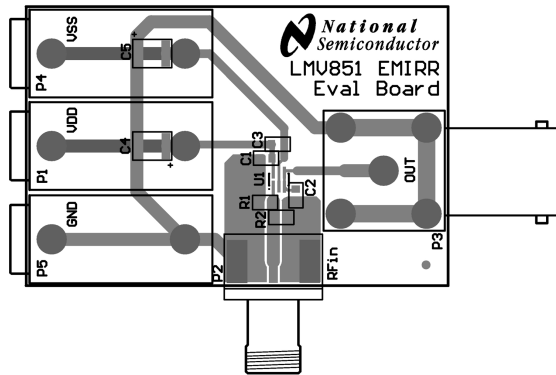

30046012

FIGURE 2. Layout for LMV851, All Layers

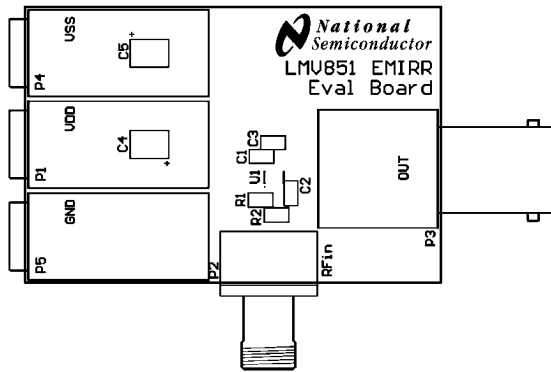

30046014

FIGURE 3. Layout for LMV851, Silk Screen

LMV852 Evaluation Board

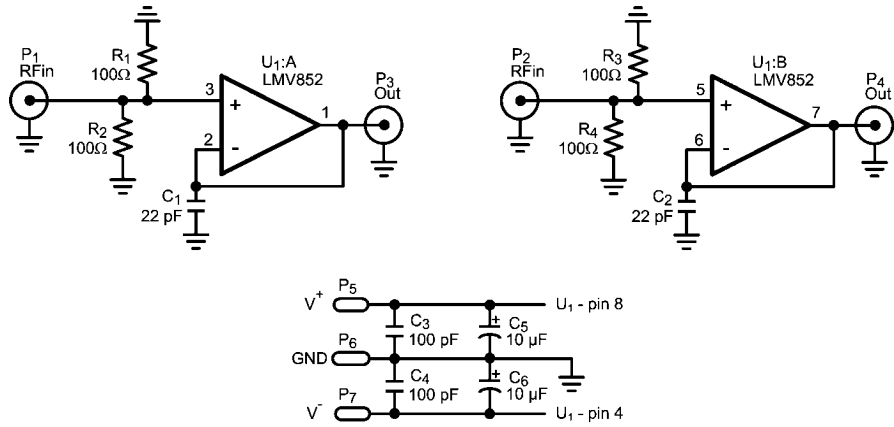

30046004

FIGURE 4. Schematic for LMV852, Coupling RF Signal to the IN+ Pin

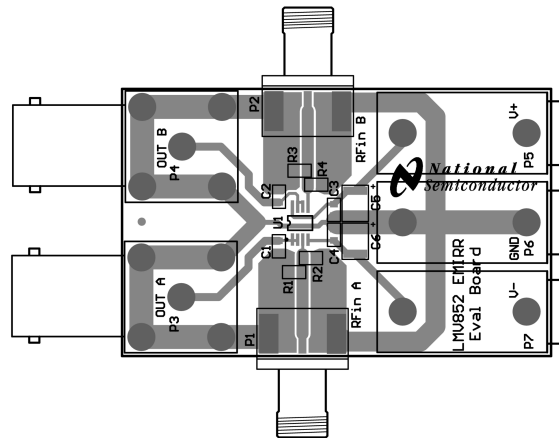

30046015

FIGURE 5. Layout for LMV852, All Layers

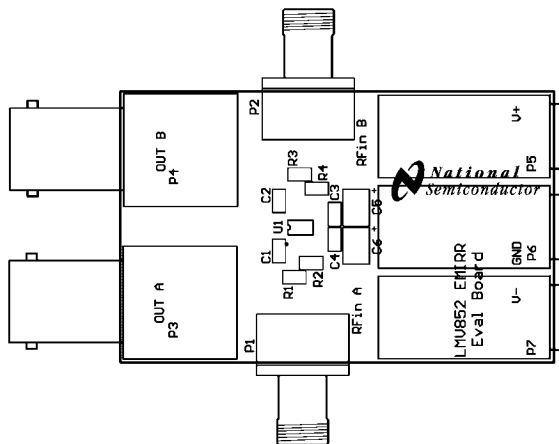

30046016

FIGURE 6. Layout for LMV852, Silk Screen

LMV854 Evaluation Board

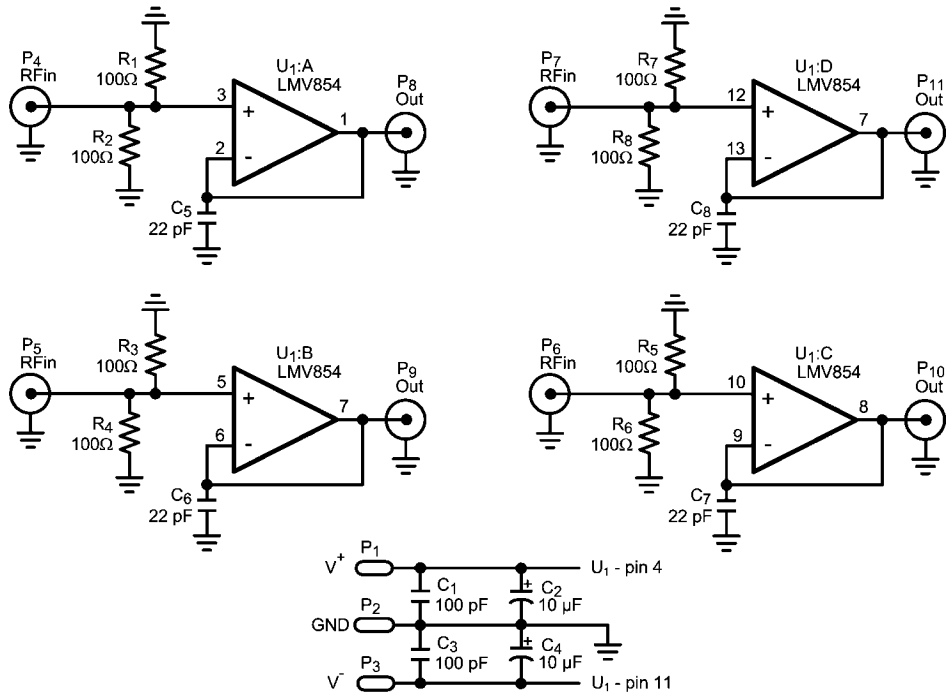

30046007

FIGURE 7. Schematic for LMV854, Coupling RF Signal to the IN+ Pin

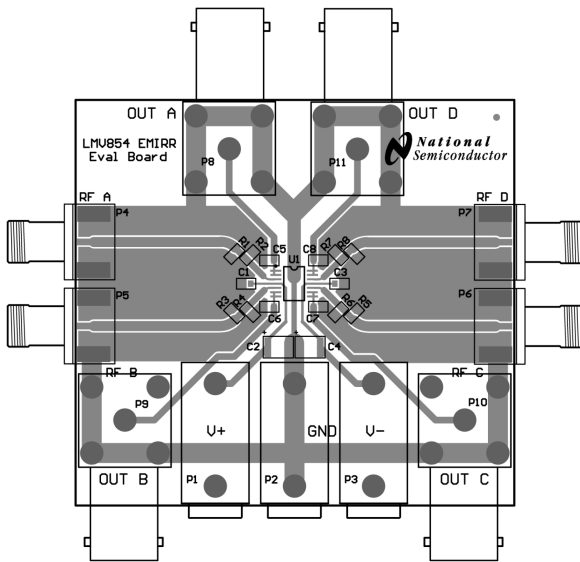

30046017

FIGURE 8. Layout for LMV854, All Layers

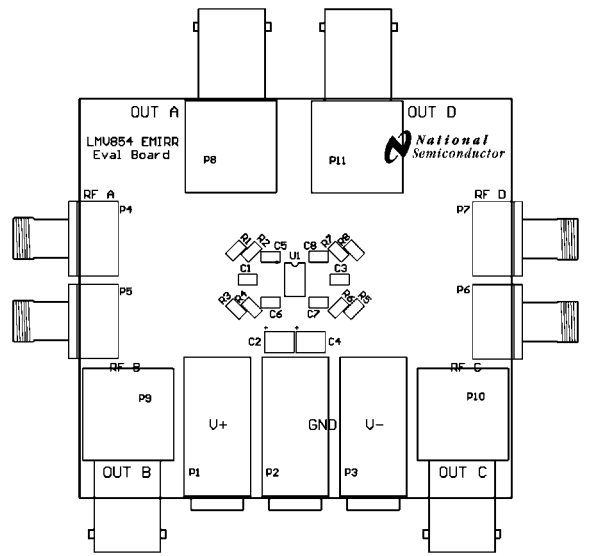

30046018

FIGURE 9. Layout for LMV854, Silk Screen

Measurement Results

To show the sensitivity of the IN+ pin two types of measurement results are presented using the LMV851 evaluation board:

- The EMIRR as a function of the *frequency* of the applied signal. The level of the signal is set to the standard level of 100 mV_P (-20 dBV_P).
- The EMIRR as a function of the *level* of the applied signal. The frequency is set to four typical values: 400 MHz, 900 MHz, 1.8 GHz, and 2.4 GHz.

EMIRR VS. FREQUENCY

Figure 10 depicts the EMIRR versus frequency for the various temperatures. The measurement is performed with a fixed RF level of -20 dBV_P and a varying RF signal frequency. The frequency range is 10 MHz to 4 GHz.

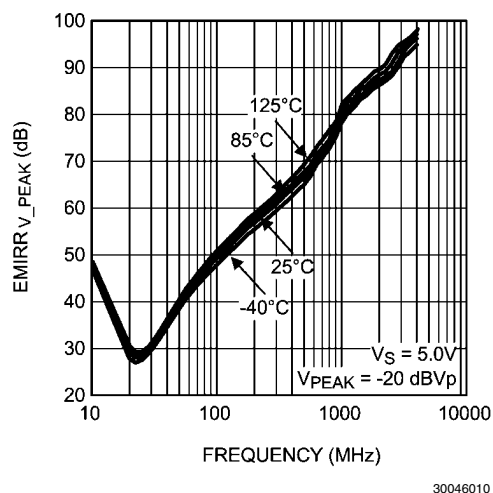
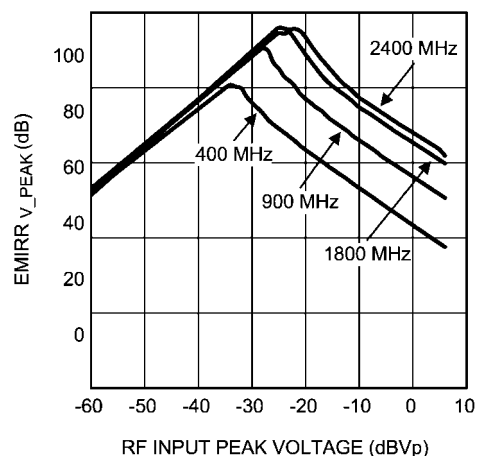

FIGURE 10. EMIRR vs. Frequency

EMIRR VS. POWER

Figure 11 depicts the EMIRR as a function of power at four typical frequencies.



30046011

FIGURE 11. EMIRR vs. Power

In this figure two areas can be distinguished. At the left side of the figure, the EMIRR increases as a function of input level; whereas at the right side the EMIRR decreases as a function of the input level.

The left side of the figure is actually an artifact resulting from the limited accuracy of the measurement setup. For the relatively low input levels, the resulting offset voltage shift is well below the noise level. Thus, when calculating the EMIRR for that region, the ratio of the input level to the noise level is depicted. As the noise level is constant for the setup, an increasing EMIRR is obtained for increasing input signal level.

For the right side, the obtained offset-shift is well above the noise level. As the relation between offset voltage shift and RF input level is quadratic, the ratio as used in the EMIRR is inversely proportional to the RF input level, which is in line with the displayed slope of “-1”.

Notes

For more National Semiconductor product information and proven design tools, visit the following Web sites at:

Products		Design Support	
Amplifiers	www.national.com/amplifiers	WEBENCH	www.national.com/webench
Audio	www.national.com/audio	Analog University	www.national.com/AU
Clock Conditioners	www.national.com/timing	App Notes	www.national.com/appnotes
Data Converters	www.national.com/adc	Distributors	www.national.com/contacts
Displays	www.national.com/displays	Green Compliance	www.national.com/quality/green
Ethernet	www.national.com/ethernet	Packaging	www.national.com/packaging
Interface	www.national.com/interface	Quality and Reliability	www.national.com/quality
LVDS	www.national.com/lvds	Reference Designs	www.national.com/refdesigns
Power Management	www.national.com/power	Feedback	www.national.com/feedback
Switching Regulators	www.national.com/switchers		
LDOs	www.national.com/ldo		
LED Lighting	www.national.com/led		
PowerWise	www.national.com/powerwise		
Serial Digital Interface (SDI)	www.national.com/sdi		
Temperature Sensors	www.national.com/tempsensors		
Wireless (PLL/VCO)	www.national.com/wireless		

THE CONTENTS OF THIS DOCUMENT ARE PROVIDED IN CONNECTION WITH NATIONAL SEMICONDUCTOR CORPORATION ("NATIONAL") PRODUCTS. NATIONAL MAKES NO REPRESENTATIONS OR WARRANTIES WITH RESPECT TO THE ACCURACY OR COMPLETENESS OF THE CONTENTS OF THIS PUBLICATION AND RESERVES THE RIGHT TO MAKE CHANGES TO SPECIFICATIONS AND PRODUCT DESCRIPTIONS AT ANY TIME WITHOUT NOTICE. NO LICENSE, WHETHER EXPRESS, IMPLIED, ARISING BY ESTOPPEL OR OTHERWISE, TO ANY INTELLECTUAL PROPERTY RIGHTS IS GRANTED BY THIS DOCUMENT.

TESTING AND OTHER QUALITY CONTROLS ARE USED TO THE EXTENT NATIONAL DEEMS NECESSARY TO SUPPORT NATIONAL'S PRODUCT WARRANTY. EXCEPT WHERE MANDATED BY GOVERNMENT REQUIREMENTS, TESTING OF ALL PARAMETERS OF EACH PRODUCT IS NOT NECESSARILY PERFORMED. NATIONAL ASSUMES NO LIABILITY FOR APPLICATIONS ASSISTANCE OR BUYER PRODUCT DESIGN. BUYERS ARE RESPONSIBLE FOR THEIR PRODUCTS AND APPLICATIONS USING NATIONAL COMPONENTS. PRIOR TO USING OR DISTRIBUTING ANY PRODUCTS THAT INCLUDE NATIONAL COMPONENTS, BUYERS SHOULD PROVIDE ADEQUATE DESIGN, TESTING AND OPERATING SAFEGUARDS.

EXCEPT AS PROVIDED IN NATIONAL'S TERMS AND CONDITIONS OF SALE FOR SUCH PRODUCTS, NATIONAL ASSUMES NO LIABILITY WHATSOEVER, AND NATIONAL DISCLAIMS ANY EXPRESS OR IMPLIED WARRANTY RELATING TO THE SALE AND/OR USE OF NATIONAL PRODUCTS INCLUDING LIABILITY OR WARRANTIES RELATING TO FITNESS FOR A PARTICULAR PURPOSE, MERCHANTABILITY, OR INFRINGEMENT OF ANY PATENT, COPYRIGHT OR OTHER INTELLECTUAL PROPERTY RIGHT.

LIFE SUPPORT POLICY

NATIONAL'S PRODUCTS ARE NOT AUTHORIZED FOR USE AS CRITICAL COMPONENTS IN LIFE SUPPORT DEVICES OR SYSTEMS WITHOUT THE EXPRESS PRIOR WRITTEN APPROVAL OF THE CHIEF EXECUTIVE OFFICER AND GENERAL COUNSEL OF NATIONAL SEMICONDUCTOR CORPORATION. As used herein:

Life support devices or systems are devices which (a) are intended for surgical implant into the body, or (b) support or sustain life and whose failure to perform when properly used in accordance with instructions for use provided in the labeling can be reasonably expected to result in a significant injury to the user. A critical component is any component in a life support device or system whose failure to perform can be reasonably expected to cause the failure of the life support device or system or to affect its safety or effectiveness.

National Semiconductor and the National Semiconductor logo are registered trademarks of National Semiconductor Corporation. All other brand or product names may be trademarks or registered trademarks of their respective holders.

Copyright© 2008 National Semiconductor Corporation

For the most current product information visit us at www.national.com



National Semiconductor Americas Technical Support Center
Email: support@nsc.com
Tel: 1-800-272-9959

National Semiconductor Europe Technical Support Center
Email: europe.support@nsc.com
German Tel: +49 (0) 180 5010 771
English Tel: +44 (0) 870 850 4288

National Semiconductor Asia Pacific Technical Support Center
Email: ap.support@nsc.com

National Semiconductor Japan Technical Support Center
Email: jpn.feedback@nsc.com

IMPORTANT NOTICE

Texas Instruments Incorporated and its subsidiaries (TI) reserve the right to make corrections, modifications, enhancements, improvements, and other changes to its products and services at any time and to discontinue any product or service without notice. Customers should obtain the latest relevant information before placing orders and should verify that such information is current and complete. All products are sold subject to TI's terms and conditions of sale supplied at the time of order acknowledgment.

TI warrants performance of its hardware products to the specifications applicable at the time of sale in accordance with TI's standard warranty. Testing and other quality control techniques are used to the extent TI deems necessary to support this warranty. Except where mandated by government requirements, testing of all parameters of each product is not necessarily performed.

TI assumes no liability for applications assistance or customer product design. Customers are responsible for their products and applications using TI components. To minimize the risks associated with customer products and applications, customers should provide adequate design and operating safeguards.

TI does not warrant or represent that any license, either express or implied, is granted under any TI patent right, copyright, mask work right, or other TI intellectual property right relating to any combination, machine, or process in which TI products or services are used. Information published by TI regarding third-party products or services does not constitute a license from TI to use such products or services or a warranty or endorsement thereof. Use of such information may require a license from a third party under the patents or other intellectual property of the third party, or a license from TI under the patents or other intellectual property of TI.

Reproduction of TI information in TI data books or data sheets is permissible only if reproduction is without alteration and is accompanied by all associated warranties, conditions, limitations, and notices. Reproduction of this information with alteration is an unfair and deceptive business practice. TI is not responsible or liable for such altered documentation. Information of third parties may be subject to additional restrictions.

Resale of TI products or services with statements different from or beyond the parameters stated by TI for that product or service voids all express and any implied warranties for the associated TI product or service and is an unfair and deceptive business practice. TI is not responsible or liable for any such statements.

TI products are not authorized for use in safety-critical applications (such as life support) where a failure of the TI product would reasonably be expected to cause severe personal injury or death, unless officers of the parties have executed an agreement specifically governing such use. Buyers represent that they have all necessary expertise in the safety and regulatory ramifications of their applications, and acknowledge and agree that they are solely responsible for all legal, regulatory and safety-related requirements concerning their products and any use of TI products in such safety-critical applications, notwithstanding any applications-related information or support that may be provided by TI. Further, Buyers must fully indemnify TI and its representatives against any damages arising out of the use of TI products in such safety-critical applications.

TI products are neither designed nor intended for use in military/aerospace applications or environments unless the TI products are specifically designated by TI as military-grade or "enhanced plastic." Only products designated by TI as military-grade meet military specifications. Buyers acknowledge and agree that any such use of TI products which TI has not designated as military-grade is solely at the Buyer's risk, and that they are solely responsible for compliance with all legal and regulatory requirements in connection with such use.

TI products are neither designed nor intended for use in automotive applications or environments unless the specific TI products are designated by TI as compliant with ISO/TS 16949 requirements. Buyers acknowledge and agree that, if they use any non-designated products in automotive applications, TI will not be responsible for any failure to meet such requirements.

Following are URLs where you can obtain information on other Texas Instruments products and application solutions:

Products

Audio	www.ti.com/audio
Amplifiers	amplifier.ti.com
Data Converters	dataconverter.ti.com
DLP® Products	www.dlp.com
DSP	dsp.ti.com
Clocks and Timers	www.ti.com/clocks
Interface	interface.ti.com
Logic	logic.ti.com
Power Mgmt	power.ti.com
Microcontrollers	microcontroller.ti.com
RFID	www.ti-rfid.com
OMAP Mobile Processors	www.ti.com/omap
Wireless Connectivity	www.ti.com/wirelessconnectivity

Applications

Communications and Telecom	www.ti.com/communications
Computers and Peripherals	www.ti.com/computers
Consumer Electronics	www.ti.com/consumer-apps
Energy and Lighting	www.ti.com/energy
Industrial	www.ti.com/industrial
Medical	www.ti.com/medical
Security	www.ti.com/security
Space, Avionics and Defense	www.ti.com/space-avionics-defense
Transportation and Automotive	www.ti.com/automotive
Video and Imaging	www.ti.com/video

TI E2E Community Home Page

e2e.ti.com

Mailing Address: Texas Instruments, Post Office Box 655303, Dallas, Texas 75265
Copyright © 2011, Texas Instruments Incorporated