



**Adding Intelligence to Lighting Applications**  
*LED Lighting Design Guide*



**Table of Contents**

LED Lighting ..... 3

LED Applications ..... 3

Efficient LED Control ..... 3

Driving LEDs with a Charge Pump ..... 4

    MCP1252 Charge Pump Backlight Demonstration Board (MCP1252DM-BKLT) ..... 4

Driving LEDs with a Boost Regulator ..... 5

    MCP1650 Multiple White LED Demonstration Board (MCP1650DM-LED2)..... 5

High Efficiency LED Smart Driver..... 6

Driving LEDs with a SEPIC Regulator ..... 7

    MCP1650 3W White LED Demonstration Board (MCP1650DM-LED1)..... 7

Adding Intelligence – PIC10F Solutions ..... 8

    Provide Simple Dimming Control ..... 8

    Integrate Multiple Tasks – PIC12 and PIC16 Mixed Signal Solutions..... 9

    Internal 5V Regulator..... 9

    Generating PWM Control Signals ..... 10

    Mixed-Signal LED Drivers ..... 11

    MCP1630 and MCP1631 High-Speed PWM Controllers ..... 12

        MCP1630 Boost Mode LED Driver Demonstration Board (MCP1630DM-LED2)..... 12

    Digital Control vs. Analog Control..... 13

    Low Cost Digital Control..... 13

    High Performance Digital Control ..... 14

Wired Communication Solutions for Lighting

    0-10V Interface..... 15

    DMX512 ..... 15

    Digitally Addressable Lighting Interface (DALI) ..... 16

    DALI Ballast Software Library ..... 16

Advanced Communication Solutions for Lighting

    ZigBee™ Protocol..... 17

    MiWi™ Protocol ..... 17

    Ethernet Interface ..... 17

    USB Interface ..... 18

    PICDEM FS-USB Demonstration Board (DM163025)..... 18

    CAN and LIN Protocols ..... 18

    PICDEM LIN Demonstration Boards (DM163005 and DM163011)..... 18

Temperature Sensing Solutions for Power LED Applications ..... 19

    Logic Output Temperature Sensors ..... 19

    Using TC6501 Open Drain Output for Current Set-Point Control ..... 20

    Using the TC6501 to Provide MCU Interrupt ..... 20

    Fan Controller Application Using TC6502..... 20

    Voltage Output Temperature Sensors ..... 21

    Using the MCP9700 to Control Current Set-Point of the MCP1630 ..... 21

    Power LED Thermal Control Circuit Using MCP9700 and MCP1650 ..... 22

Getting Started ..... 23

## LED Lighting

LEDs are no longer used just for providing the pretty red and green indicator lights on electronic equipment. Advances in technology have allowed LEDs to be used as practical sources of illumination. The primary benefits of LEDs are long life, durability and efficiency. When driven properly, a power LED can last tens of thousands of hours without a degradation of light output. The typical efficacy of a power LED, measured in lumens per watt, is 40-80. This is several times greater than incandescent light sources and is only exceeded by fluorescent light sources. Since the LED is a solid-state device, it can withstand shock and vibration that would damage a filament bulb.

## LED Applications

The benefits of LED lighting are helpful in many types of lighting applications:

- Automotive and aircraft cabin lighting
- Automotive and aircraft instrument panel lighting
- Architectural emergency exit lighting
- Architectural color effect lighting
- Industrial and outdoor lighting
- Traffic and railway signals
- Automotive brake lights
- Dot matrix signs and video displays
- LCD display backlighting
- Personal flashlights
- Medical instrument and tool lighting
- Digital camera flash and video light

## Efficient LED Control

LEDs must be driven with a source of constant current. Most LEDs have a specified current level that will achieve the maximum brightness for that LED without premature failures. An LED could be driven with a linear voltage regulator configured as a constant current source. However, this approach is not practical for higher power LEDs due to power dissipation in the regulator circuit. A switch-mode power supply (SMPS) provides a much more efficient solution to drive the LED.

An LED will have a forward voltage drop across its terminals for a given current drive level. The power supply voltage and the LED forward voltage characteristics determine the SMPS topology that is required. Multiple LEDs can be connected in series to increase the forward voltage drop at the chosen drive current level.

The SMPS circuit topologies adopted to regulate current in LED lighting applications are the same used to control voltage in a power supply application. Each type of SMPS topology has its advantages and disadvantages as presented in the table below.

This design guide presents two types of LED driver solutions. First, an analog driver IC can be used independently or together with a MCU for added intelligence. Second, the LED drive function can be integrated into the MCU application.

## Literature on the Web

- AN1114 – Switch Mode Power Supply (SMPS) Topologies (Part I), DS01114
- AN1207 – Switch Mode Power Supply (SMPS) Topologies (Part II), DS01207

## Common SMPS Topologies Useful for LED Lighting

| Regulator Topology | V <sub>IN</sub> to V <sub>OUT</sub> Relationship       | Complexity | Component Count | Comments  |
|--------------------|--|------------|-----------------|---|
| Charge Pump        | -V <sub>OUT</sub> < V <sub>IN</sub> < V <sub>OUT</sub> | Low        | Medium          | <ul style="list-style-type: none"> <li>- Limited I<sub>OUT</sub> range</li> <li>- No inductors</li> </ul>                             |
| Buck               | V <sub>IN</sub> > V <sub>OUT</sub>                     | Medium     | Medium          | <ul style="list-style-type: none"> <li>- Chopped I<sub>IN</sub></li> <li>- High side drive</li> </ul>                                 |
| Boost              | V <sub>IN</sub> < V <sub>OUT</sub>                     | Medium     | Medium          | <ul style="list-style-type: none"> <li>- Extra parts needed to isolate output from input</li> </ul>                                   |
| SEPIC              | V <sub>OUT</sub> < V <sub>IN</sub> < V <sub>OUT</sub>  | Medium     | High            | <ul style="list-style-type: none"> <li>- Smooth I<sub>IN</sub></li> <li>- Multiple outputs</li> <li>- Two inductors</li> </ul>        |
| Buck-Boost         | V <sub>OUT</sub> < V <sub>IN</sub> < V <sub>OUT</sub>  | Medium     | Medium          | <ul style="list-style-type: none"> <li>- Single inductor</li> <li>- Up to four switches</li> </ul>                                    |
| Flyback            | Depends on transformer                                 | Medium     | Medium          | <ul style="list-style-type: none"> <li>- Transformer can provide electrical isolation</li> <li>- Multiple outputs possible</li> </ul> |

## Driving LEDs with a Charge Pump

A charge pump power supply does not have inductors that are required in other SMPS topologies. This provides a more compact and less expensive circuit. The downside is that charge pumps cannot supply large amounts of current compared to the other topologies. Charge pump circuits are most useful for backlighting applications. Common applications include PCs, LCD displays and automotive instrumentation.

### Literature on the Web

- MCP1252/3 Data Sheet, DS21572
- MCP1252 Charge Pump Backlight Demo Board User's Guide, DS51551
- MCP1252/3 Evaluation Kit User's Guide, DS51313
- DG10 – Power Solutions Design Guide, DS21913

### Charge Pump LED Driver Using the MCP1252

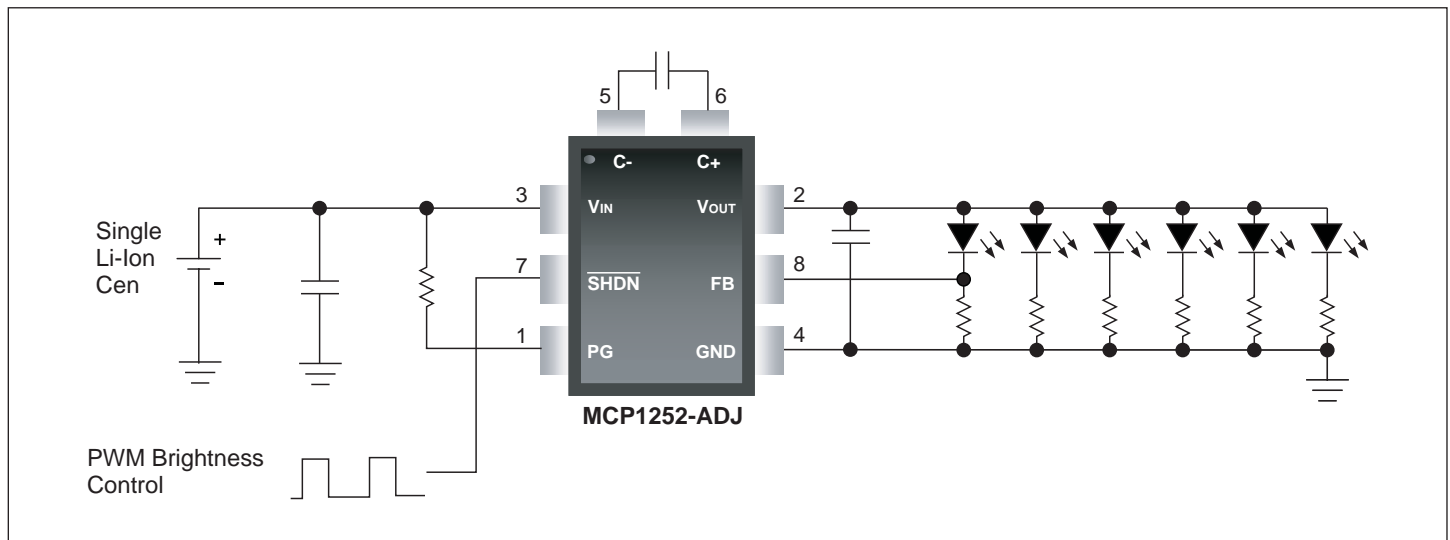

## MCP1252 Charge Pump Backlight Demonstration Board



**Part Number: MCP1252DM-BKLT**

Demonstrates the use of a charge pump device in an LED application and acts as a platform to evaluate the MCP1252 device in general. Light intensity is controlled uniformly through the use of ballast resistors. A PIC10F206 MCU provides an enable signal to the MCP1252 and accepts a push-button input that allows the white LEDs to be adjusted to five different light intensities.

## Driving LEDs with a Boost Regulator

A boost regulator topology is used when the output voltage of the converter must be equal to or greater than the input voltage. A boost regulator is useful for driving a chain of LEDs connected in series. It is beneficial to drive multiple LEDs in series. This ensures that all LEDs receive the same amount of current and will have the same brightness level. Using a coupled inductor in the boost circuit reducing the switching voltage requirements of the MOSFET switch.

An additional advantage of the MCP1650 in battery applications is the Gated Oscillator Architecture which provides 2 duty cycles reducing high-peak inductor current and output ripple voltages. Input voltages above 3.8V engage a 56% duty cycle and an 80% duty cycle when the input voltage drops below 3.8V, extending battery life in these applications.

## MCP1650 Multiple White LED Demonstration Board



Part Number: MCP1650DM-LED2

The MCP1650 Multiple White LED Demo Board uses the MCP1650 IC to power the nine white LEDs which are connected in series. A PIC10F202 microcontroller in a SOT-23 6-pin package is used to provide the PWM signal to the MCP1650. It also accepts a push button input that allows the user to adjust the white LEDs to three different intensities of 100%, 50% and 25%.

### Literature on the Web

- MCP1650/51/52/53 Data Sheet, DS21876
- MCP1650 Multiple White LED Demo Board User's Guide, DS51586
- AN948 – Efficiently Powering Nine White LEDs Using the MCP1650, DS00948
- AN980 – Designing a Boost-Switching Regulator with the MCP1650, DS00980
- DG10 – Power Solutions Design Guide, DS21913

## Battery Operated Boost LED Driver Example Using the MCP1650

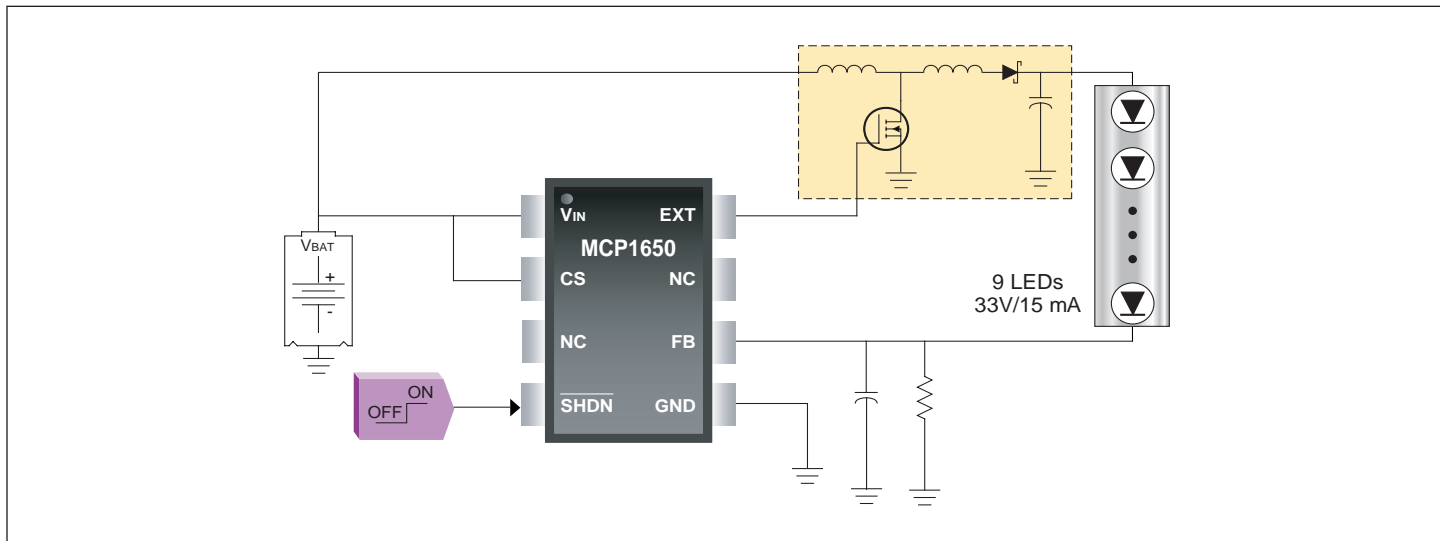



## High Efficiency LED Smart Driver

9-13 volt systems easily adapt to a Smart Driver Circuit to drive High Power LEDs using the MCP1702, MCP1652 and a PIC10F202. The MCP1702 directly connected to the 12 volt source creates a 5 volt bias supply capable of delivering 250 mA to the intelligent boost control circuit. The LEDs are powered by the source voltage boosted by the MCP1652, minimizing the current requirements for the 5V power system. A PIC10F202 adds intelligence to the circuit providing a means for thermal protection, load open and short circuit protection as well as the capability of a user interface to control dimming and other features.

Low Battery Detect enables the designer to determine a trip point for a low battery condition to make “smart” adjustments to the circuit function with the PIC10F202. The Power Good Indication enables the designer to determine when output voltage conditions are correct.

## Literature on the Web

- MCP1650/51/52/53 Data Sheet, DS21876
- AN980 – Designing a Boost-Switching Regulator with the MCP1650, DS00980
- DG10 – Power Solutions Design Guide, DS21913

## MCP165X Driver Devices

| Device  | Special Features                             | Package     |
|---------|--|-------------|
| MCP1650 | Standard Device                              | 8-Pin MSOP  |
| MCP1651 | Low Battery Detect                           | 8-Pin MSOP  |
| MCP1652 | Power Good Indication                        | 8-Pin MSOP  |
| MCP1653 | Low Battery Detect and Power Good Indication | 10-Pin MSOP |

## LED Smart Driver with 12V Input

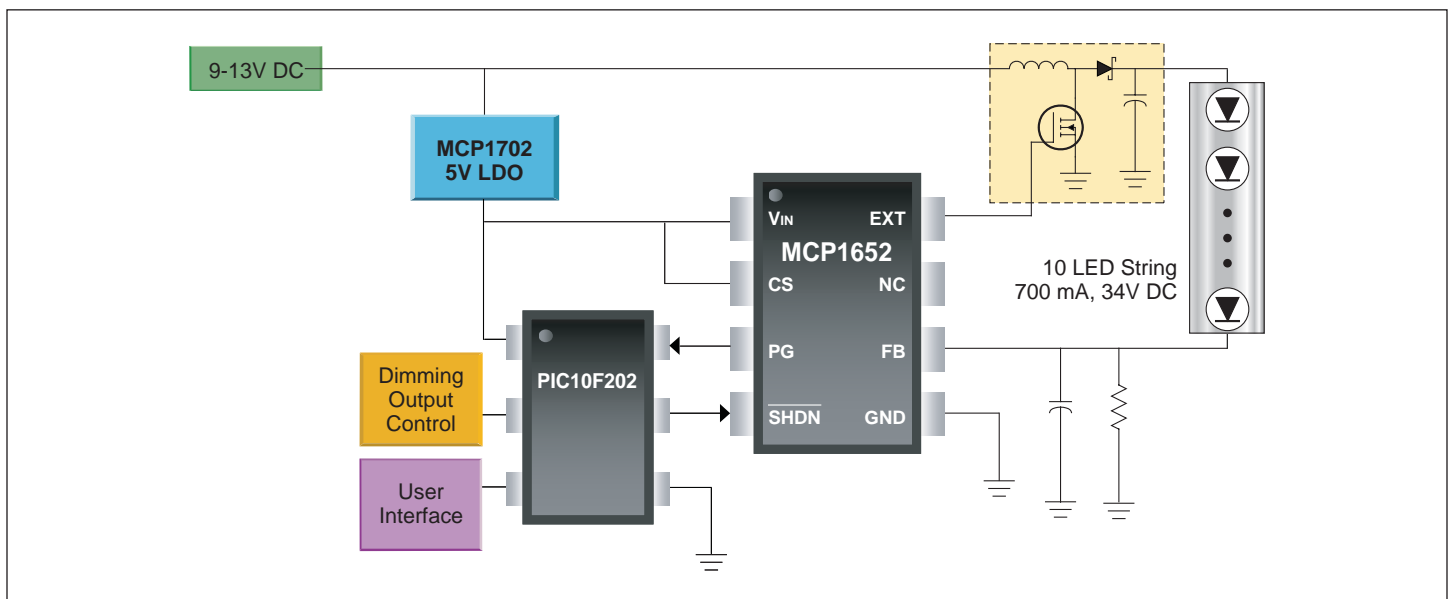

## Driving LEDs with a SEPIC Regulator

The Single-Ended Primary Inductance Converter (SEPIC) regulator topology uses an additional inductor, but provides the following advantages for battery powered applications:

- The converter can buck or boost as the input voltage changes.
- The circuit topology provides inherent short-circuit protection due to the use of a coupling capacitor.

### Literature on the Web

- MCP1650/51/52/53 Data Sheet, DS21876
- MCP1650 3W White LED Demo Board User's Guide, DS51513
- DG10 – Power Solutions Design Guide, DS21913

## MCP1650 3W White LED Demonstration Board



Part Number: MCP1650DM-LED1

Demonstrates the MCP165X Boost Controller product family in a battery-powered white LED application with an input voltage range of 2.0V to 4.5V.

### Battery Input to 3.6V 3W LED Driver (SEPIC Converter)

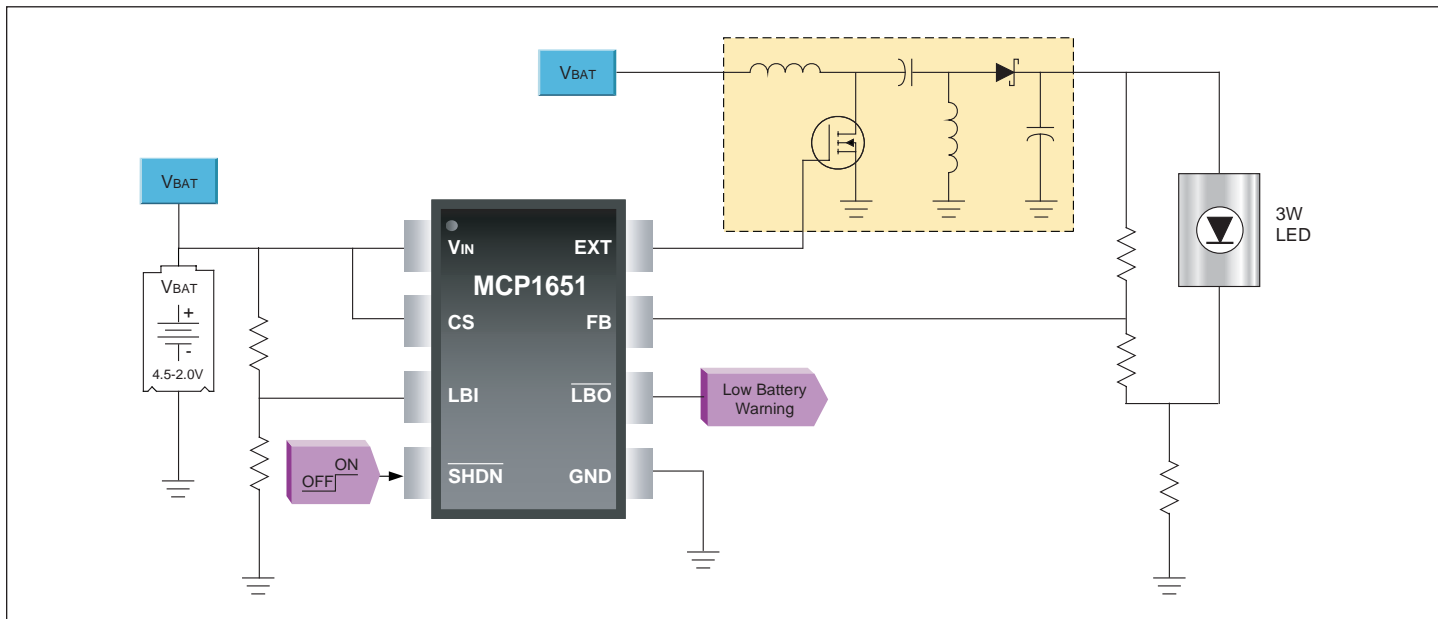

Adding Intelligence – PIC10F Solutions



LED lighting applications can benefit from the intelligence of a MCU. The MCU can be used for a variety of tasks, including the user interface, communication, battery status monitoring and temperature measurement.

The addition of a MCU to a design does not have to be complicated, space consuming, or expensive. Microchip offers the PIC10F family of MCUs with devices that have 6 pins in a SOT-23 style package. The oscillator and reset circuitry are inside the device. Connect power, ground, and you get four I/O pins that can be programmed to do anything you want. It's as simple as that.

The PIC10F pins can be used as analog or digital pins. Two devices in the PIC10F family have analog comparator modules. Two PIC10F devices are available with an 8-bit analog to digital converter (ADC). There are only 33 assembly instructions to learn in order to write code for the PIC10F. There are also C compilers are available for the PIC10F family, if you prefer to write in a high-level language.

**PIC10F 6-Pin Microcontroller Family**

| Device    | Flash Program Memory Words | Data RAM Bytes | 8-Bit Timer | Analog Comparator Module | 8-bit ADC Module |
|-----------|----------------------------|----------------|-------------|--------------------------|------------------|
| PIC10F200 | 256                        | 16             | Yes         | –                        | –                |
| PIC10F202 | 512                        | 24             | Yes         | –                        | –                |
| PIC10F204 | 256                        | 16             | Yes         | Yes                      | –                |
| PIC10F206 | 512                        | 24             | Yes         | Yes                      | –                |
| PIC10F220 | 256                        | 16             | Yes         | –                        | Yes              |
| PIC10F222 | 512                        | 24             | Yes         | –                        | Yes              |

### Package Comparison SOT-23 vs. MSOP and SOIC



6-SOT (OT)  
3 x 3 mm  
PIC10F2XX



8-MSOP (MS)  
3 x 5 mm



8-SOIC (SN)  
5 x 6 mm

Shown approximate size.

**Provide Simple Dimming Control**

One application for a MCU in LED lighting is brightness control. A power LED can be dimmed by reducing the drive current. However, this is not the most efficient way to control the brightness of a LED. A power LED provides the best efficiency at the maximum rated drive current. Better efficiency can be obtained by turning the LED on and off using a low frequency PWM signal. The PWM signal is connected to the enable input of the SMPS control IC. The LED is always driven at the maximum current level when it is on.

The MCP1650 Multiple White LED Demo Board and the MCP1650 3W White LED Demo Board both take advantage of the 6-pin PIC10F206 MCU (see pages 5-7 for more information). The PIC10F206 device provides the user button interface and generates the PWM control signal for the SMPS IC. The PIC10F206 has an internal oscillator and reset circuit, so no external circuitry is required. The PIC10F206 device could also be used to linearize the brightness control or monitor battery status in these applications.



## Integrate Multiple Tasks – PIC12 and PIC16 Mixed Signal Solutions

The LED current drive function can be integrated with other tasks on the same MCU. Members of the PIC12F and PIC16F device families provide the next step up from the PIC10F family and facilitate highly integrated mixed signal designs in 8, 14 and 20-pin package options. The available peripherals in this series of devices include:

- Shunt Voltage Regulator
- Comparators
- Op Amps
- ADC
- Voltage Reference
- Hardware PWM (Digital Timebase or SR Latch)

These peripherals allow external power circuits to be directly controlled by the MCU. For a LED driver application, the analog peripherals can be configured and interconnected in software to provide constant current regulation. This leaves the CPU free to run other tasks such as communication, dimming control or fault detection.

### Internal 5V Regulator

The internal shunt voltage regulator option allows the MCU to be operated from a higher voltage DC bus making it useful in AC line powered applications. Only a series resistor is required between the power supply and the device V<sub>DD</sub> pin.

Devices with an “HV” designator in the part number have an internal regulator.

### Easy Migration

The 8, 14 and 20-pin devices in the PIC12F and PIC16F families have compatible pin-outs for upward and downward migration. Common connections such as power and ground are located in the same positions on the package footprint so that an 8-pin design can easily be expanded to a 14 or 20-pin design.

### Literature on the Web

- AN1035 – Designing with HV Microcontrollers, DS01035
- PIC16F785/HV785 Device Data Sheet, DS41249

### Web Links

[www.microchip.com/startnow](http://www.microchip.com/startnow)

### Compatible Pinouts Provide Migration Options

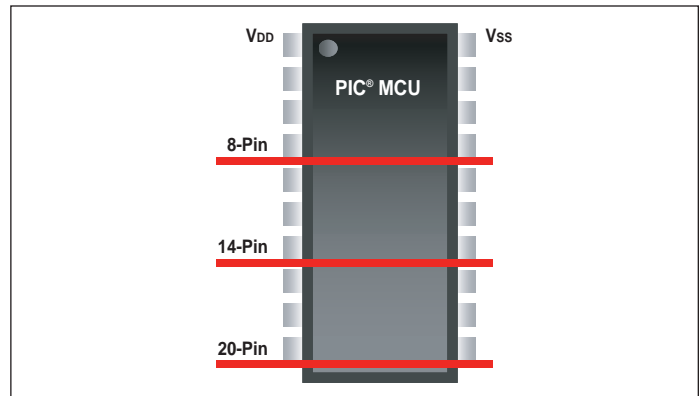

## 8, 14 and 20-Pin PIC® Microcontroller Mixed Signal Features

| Device               | Pins | Voltage Reference | Analog Comparator | Op Amps | ADC    | Digital PWM Module | PWM SR Latch |
|----------------------|------|-------------------|-------------------|---------|--------|--------------------|--------------|
| PIC12F609/PIC12HV609 | 8    | –                 | 1                 | –       | –      | –                  | –            |
| PIC12F615/PIC12HV615 | 8    | –                 | 1                 | –       | 10-bit | ECCP               | –            |
| PIC16F610/PIC16HV610 | 14   | –                 | 2                 | –       | –      | –                  | 1            |
| PIC16F616/PIC16HV616 | 14   | –                 | 2                 | –       | 10-bit | ECCP               | 1            |
| PIC16F785/PIC16HV785 | 20   | Yes               | 2                 | 2       | 10-bit | CCP                | 2            |

Note: ‘HV’ part numbers have internal shunt voltage regulator. All devices have internal 8 MHz oscillator.

## Generating PWM Control Signals

There are multiple ways to generate PWM control signals to control power circuits.

- Devices with the Capture-Compare-PWM (CCP) module can generate PWM signals to control power circuits using an on-chip digital timebase. The signal pulse width is controlled by the MCU clock and a duty cycle register.
- The Enhanced CCP (ECCP) module allows one PWM signal to control 2 or 4 output pins for half-bridge or H-bridge control, respectively.
- Devices that have a comparator and the ECCP module can use the comparator signal to control the turn-off time of the PWM signal.
- Devices with comparators and a PWM SR latch can use comparator signals and/or clock pulses to turn the latch output on and off.

- An external PWM peripheral IC may be used. This option is useful when multiple high speed PWM channels are required.
- PWM signals can be generated using software and I/O pins. This option is less costly when PWM frequency and duty cycle resolution requirements are not too high.

A PIC microcontroller with an on-chip comparator such as the PIC12HF609 can be used to implement a simple LED driver. The PIC12HV609 adds an internal regulator, allowing operation from a DC bus higher than 5 volts.

### Literature on the Web

- AN874 – Buck Configuration High-Power LED Driver, DS00874
- AN1074 – Software PWM Generation for LED Dimming and RGB Color Applications, DS01074

## Buck LED Driver Using a Comparator

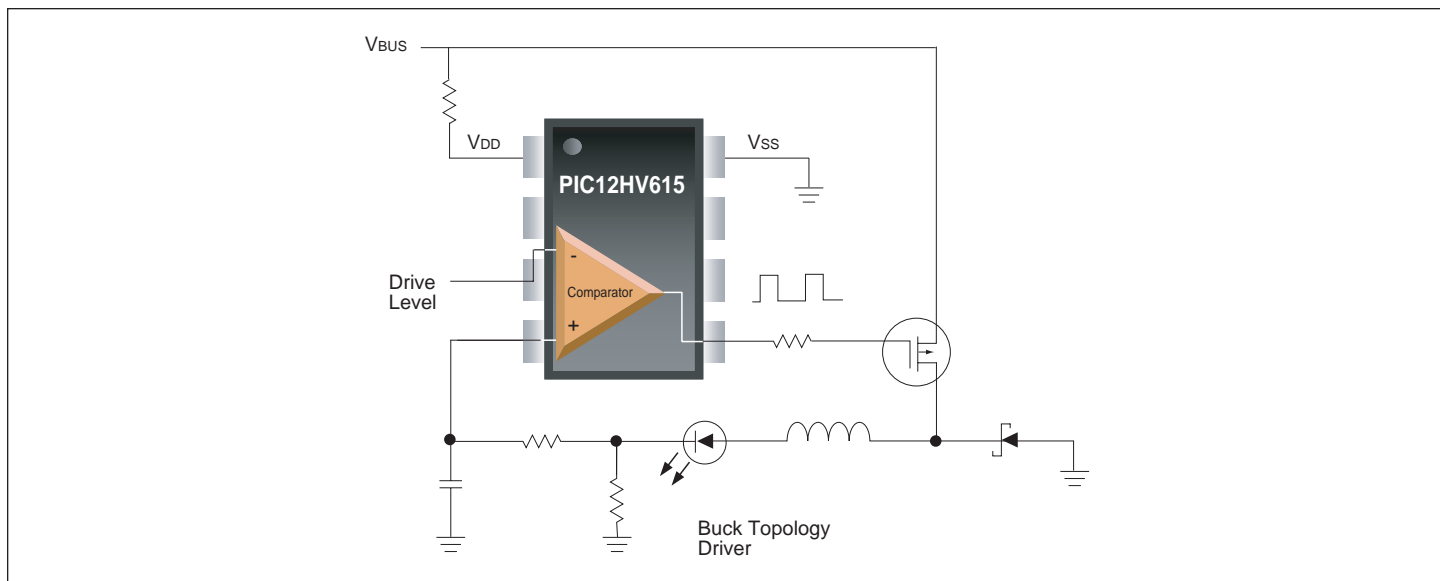

## RGB Color LED Application Using PIC12HV615

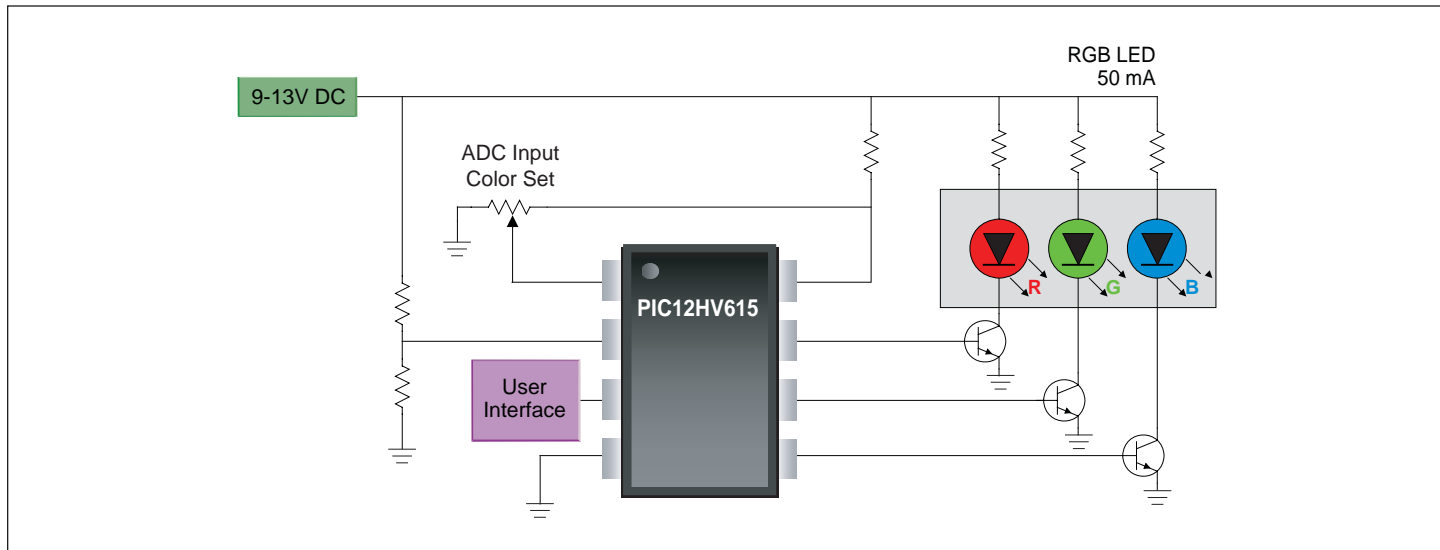

## Mixed-Signal LED Drivers

Some devices, such as the PIC16F616, have a SR latch module that can be used in many different ways along with the comparators and other digital signal events. Events such as clock pulses or comparator signals can be programmed to set or reset the SR latch. These programming options allow almost any kind of control signal to be generated.

The PIC16F785 has two on-chip op amps, two on-chip comparators, two SR latch PWM modules and an adjustable voltage reference. This combination of peripherals can be digitally configured to implement a wide variety of SMPS circuit topologies.

### Literature on the Web

- AN1035 – Designing with HV Microcontrollers DS01035
- AN1047 – Buck-Boost LED Driver Using the PIC16F785 MCU, DS01047
- PIC16F785/HV785 Device Data Sheet, DS41249

## PIC16HV785 Boost LED Driver Application

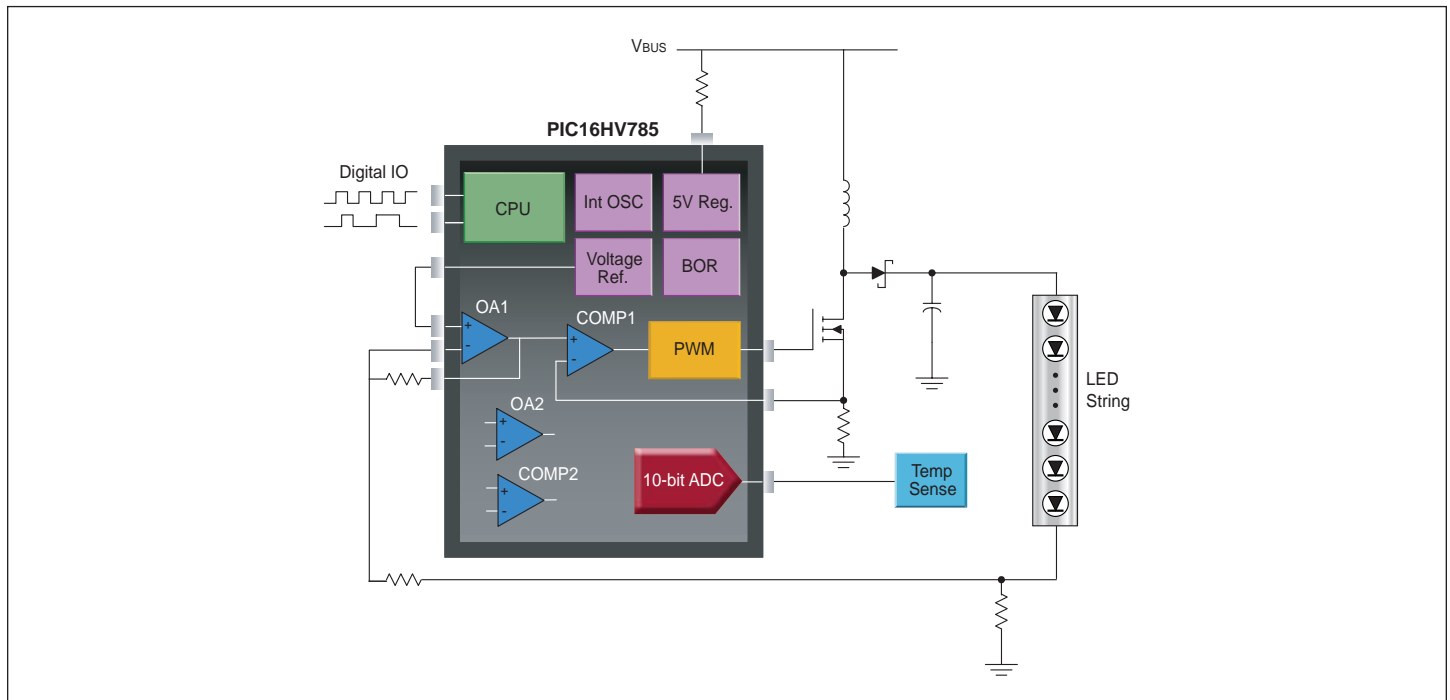

## PIC16HV785 Flyback Converter with PFC and Dimming Control

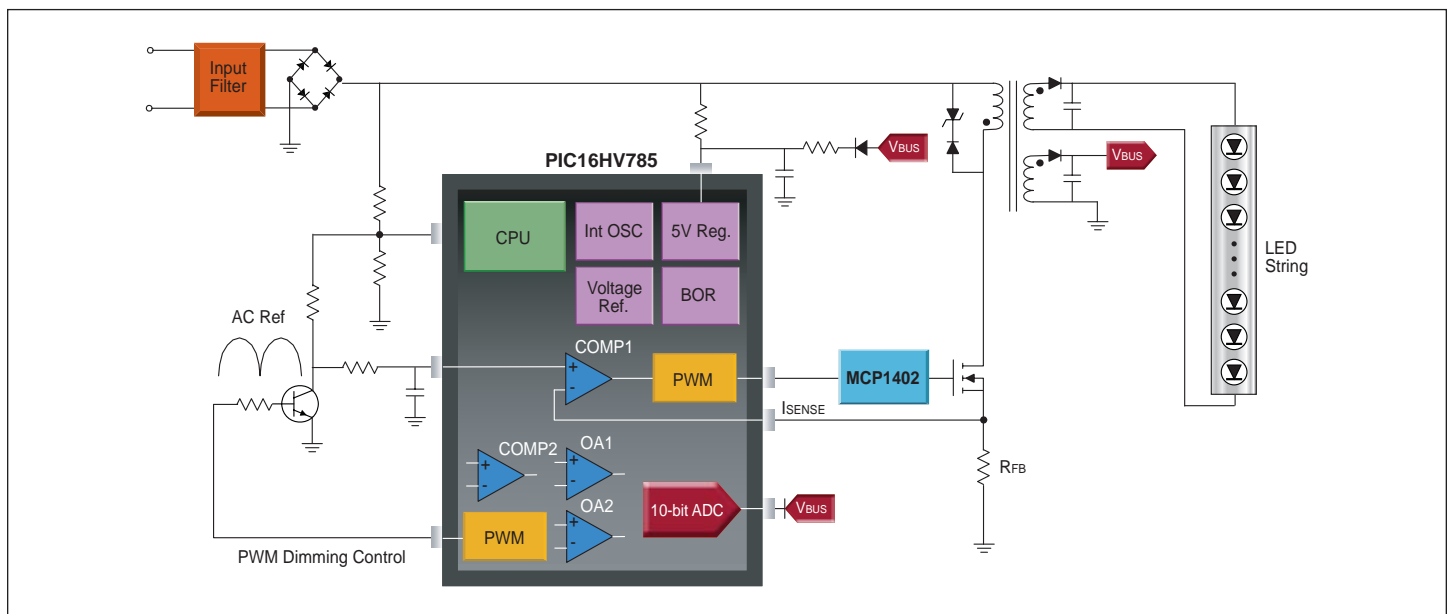

### MCP1630 and MCP1631 High-Speed PWM Controllers

The MCP1630 and MCP1631 offer another method that can be used to generate high speed PWM signals for high power LED drivers. The MCP1630 is an 8-pin device that contains the components needed to generate an analog PWM control loop, including an error amplifier, comparator and a high current output pin to drive a power transistor.

The MCP1630 is designed to be used with a MCU that provides a reference clock source. The MCU controls the PWM frequency and maximum duty cycle. The switching frequency can be up to 1 MHz, depending on the application requirements. The MCU can also control the reference input for the error amplifier when dimming or soft start functions are required. Multiple MCP1630 devices can be attached to a MCU to support multiple power channels.

The MCP1630 can be used to solve advanced power supply issues. When multiple MCP1630 devices are used, phase offsets can be applied to each clock input to reduce bus current ripple. For applications that are sensitive to EMI, dithering can be applied to the clock signal to reduce radiated energy at a given frequency.

The MCP1631 is a 20-pin device which, in addition to the MCP1630 includes an internal 5V or 3.3V regulator, shutdown control, overvoltage protection, oscillator disable and 1x and 10x gain amplifiers.

### MCP1630 Boost Mode LED Driver Demonstration Board



Part Number: MCP1630DM-LED2

This demo board is a step-up, switch-mode, DC-DC converter used for power LED applications. The demo board provides a 350 mA or 700 mA constant current source with a jumper selection. The input operating voltage range is 9-16 VDC and the board can supply up to 30W to a string of power LEDs.

### Literature on the Web

- MCP1630/MCP1630V Device Data Sheet, DS21896
- MCP1631 Device Data Sheet, DS22063

### MCP1631VHV Block Diagram

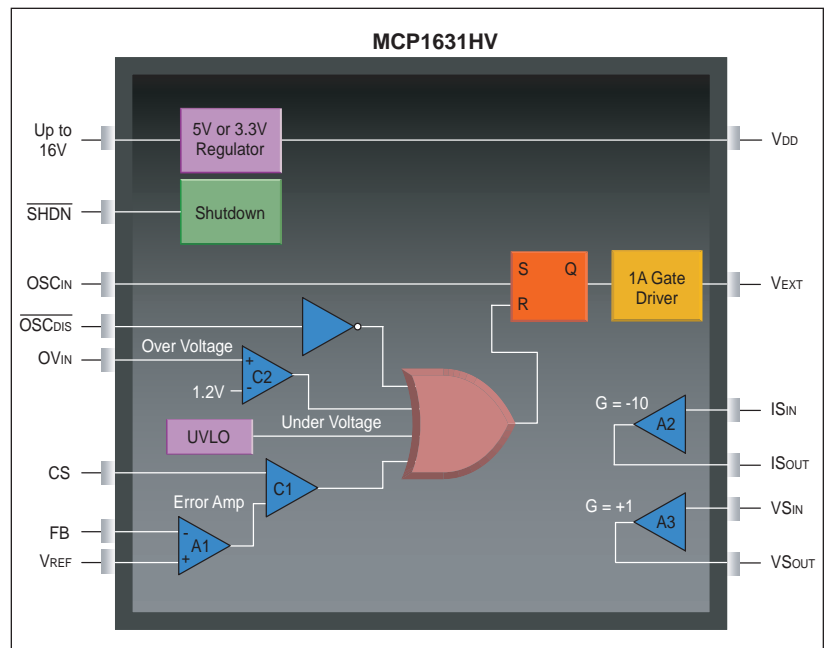

### MCP1630 Boost Mode LED Driver

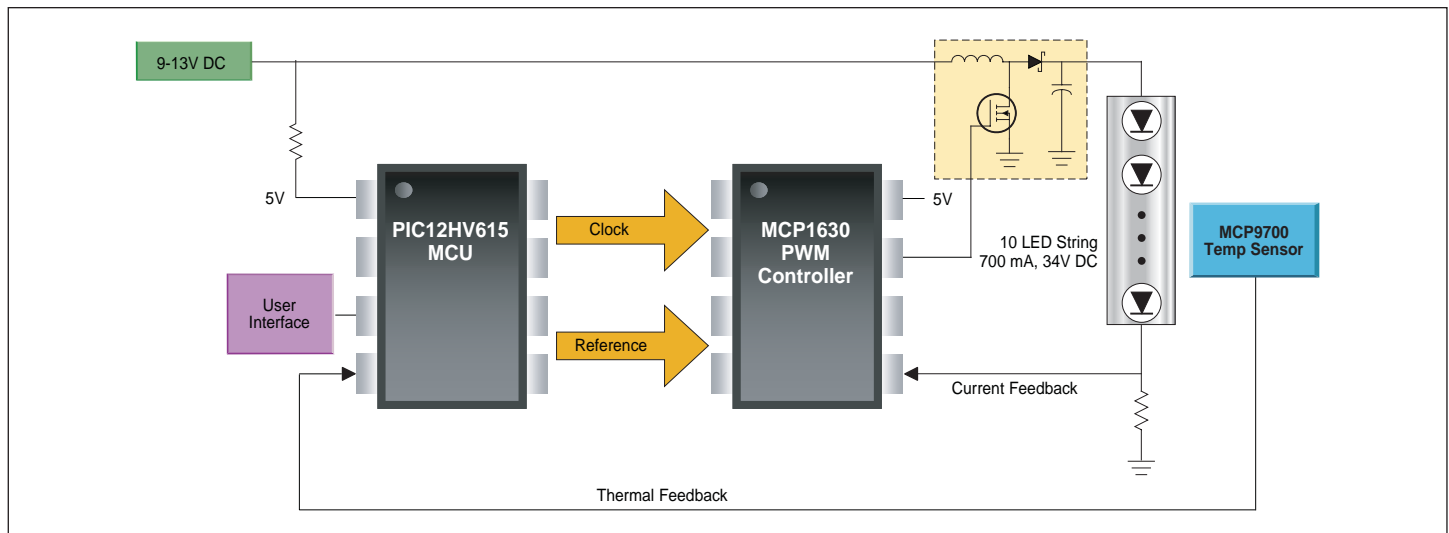

### Digital Control vs. Analog Control

LEDs can be driven with a fully digital control loop. Instead of measuring the LED current with an op amp or comparator circuit, the LED current is sampled using an ADC. Some type of digital algorithm replaces the analog control loop. A proportional-integral-derivative (PID) control algorithm is commonly used because it has software coefficients that can readily be adjusted to affect the controller behavior. A digital PWM peripheral is used to drive the LED. The digital algorithm computes an output based on its inputs and provides the duty cycle for the PWM peripheral.

#### Literature on the Web

- AN1138 – A Digital Constant Current Power LED Driver, DS01138

### Low Cost Digital Control

Some power supply applications require fast dynamic response to compensate for load changes. In these applications, a fast ADC and fast calculation performance are required. However, a LED provides a stable load for a constant-current power supply. Therefore, a fast ADC and fast processing power are not always required to implement a digital control loop for a LED driver application.

A low-cost device in the PIC12F or PIC16F family with a CCP peripheral and an ADC can be used to implement a LED driver using digital control. The CCP peripheral is used in PWM mode to control the power supply circuit. Operating from the internal 8 MHz device oscillator, the CCP can provide PWM frequencies above 100 KHz to keep power component sizes small. Since the LED provides a constant load, it is sufficient to sample the output current and adjust the PWM duty cycle at a much lower rate. A sample rate of 1000 Hz is ideal for many applications.

### Comparison of Digital Control vs. Analog Control Functions

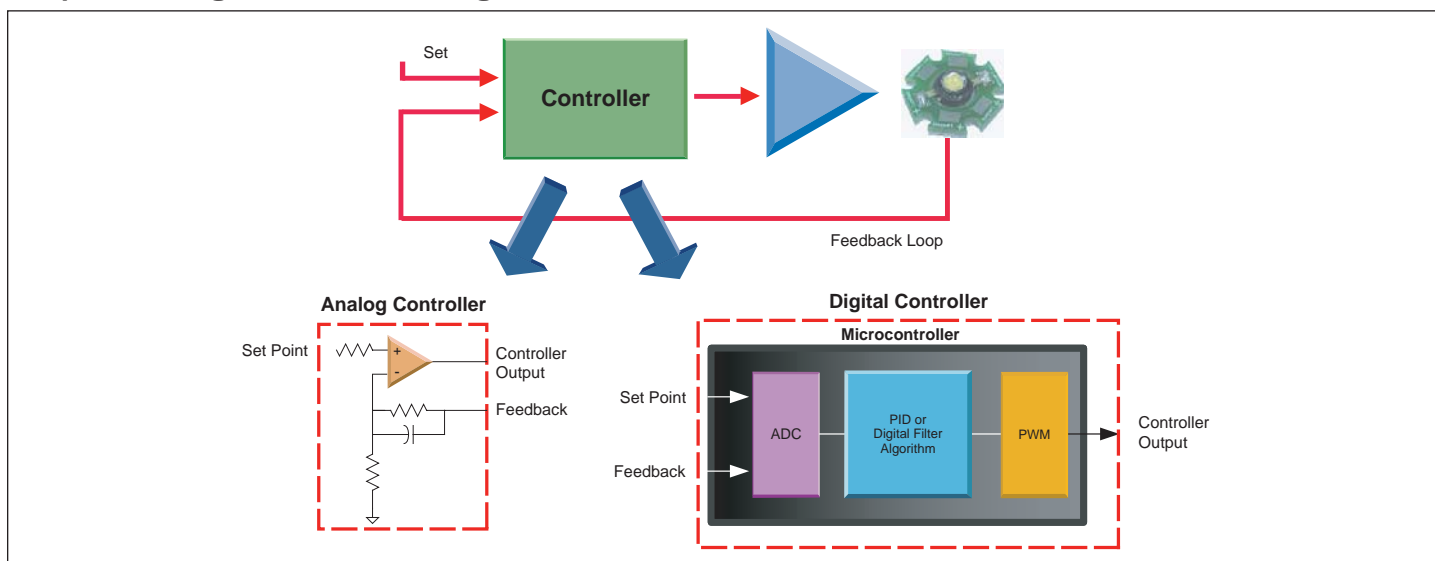

### PIC12HV615 Buck LED Driver with Digital Control

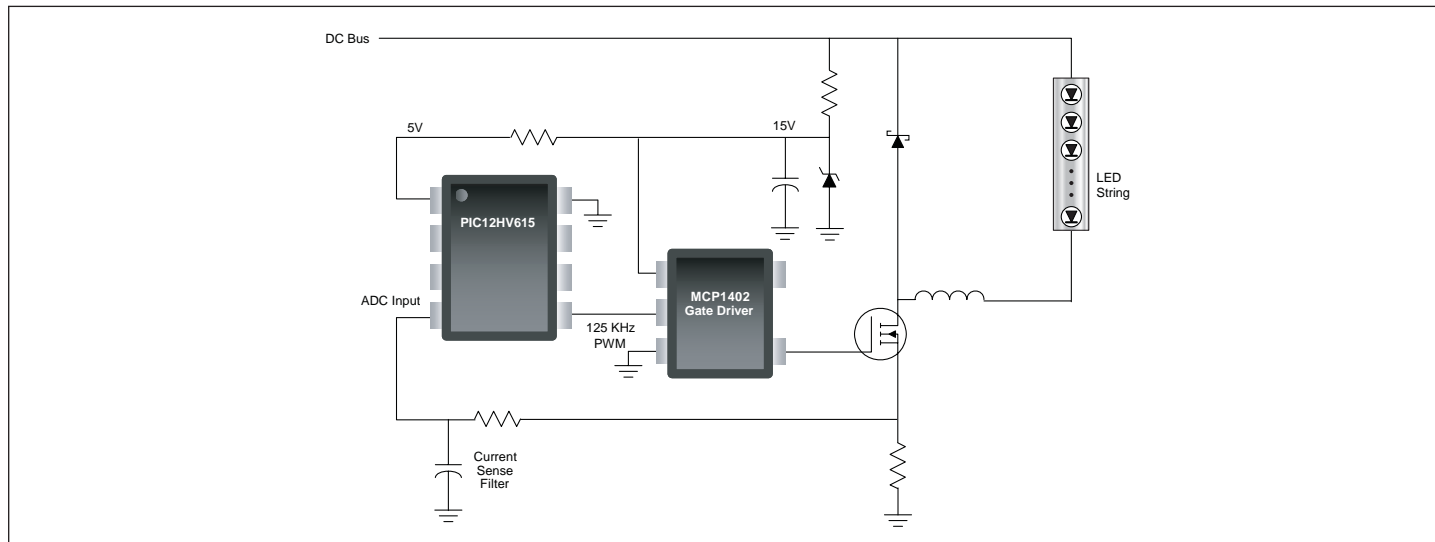



## High Performance Digital Control

Devices in the PIC18F and dsPIC30F families offer 8-bit and 16-bit solutions for fast calculation of digital control loops. In addition, these families have device variants with fast ADC peripherals and specialized PWM modules that are optimized for power control applications.

A selection of devices for digital power control is shown in the table below. There are many other Microchip devices that could be used, but these devices represent low-cost and small package choices.

Devices in the PIC18F family have an 8-bit CPU with a hardware multiplier. The PIC18 is a good choice for moderate control loop rates (1 KHz-10 KHz). Devices in the dsPIC30F family have a 16-bit CPU with DSP resources. The dsPIC30F family is a good choice if you need to execute multiple control loops at a faster rate.

All devices shown in the table have advanced PWM modules with two output pins per PWM channel. All of these devices can generate complementary PWM output signals with dead time for driving  $\frac{1}{2}$  bridge and H bridge power circuits.

The dsPIC30F1010 device has a Power Supply PWM module that can generate high switching frequencies with very fine edge resolution. This PWM module can also generate phase shifted PWM signals for advanced power supply applications.

The 28-pin dsPIC30F1010 device can provide a highly integrated solution for LED lighting applications. The PWM peripheral can drive 3 strings of LEDs, replacing 3 separate analog control ICs. Furthermore, there are resources left over for active power factor correction (PFC) and digital communications.

### Literature on the Web

- PIC18F1230/1330 Device Data Sheet, DS39758
- dsPIC30F2010 Device Data Sheet, DS70118
- dsPIC30F1010/202X Device Data Sheet, DS70178
- AN937 – Implementing a PID Controller Using a PIC18 MCU, DS00937

### Selected Devices for Digital Power Control

| Device            | Pins | Architecture | ADC              | PWM                    |
|-------------------|------|--------------|------------------|------------------------|
| PIC18F1230        | 18   | 8-bit MCU    | 10-bit, 200 KSPS | 3-channel              |
| PIC18F2331        | 28   | 8-bit MCU    | 10-bit, 200 KSPS | 3-channel              |
| dsPIC33FJ12MC201  | 20   | 16-bit DSC   | 10-bit or 12-bit | 3-channel              |
| dsPIC30F1010 SMPS | 28   | 16-bit DSC   | 10-bit, 1 MSPS   | 4-channel Power Supply |
| dsPIC30F2010      | 28   | 16-bit DSC   | 10-bit, MSPS     | 3-channel              |

### Multiple LED Driver Application with PFC

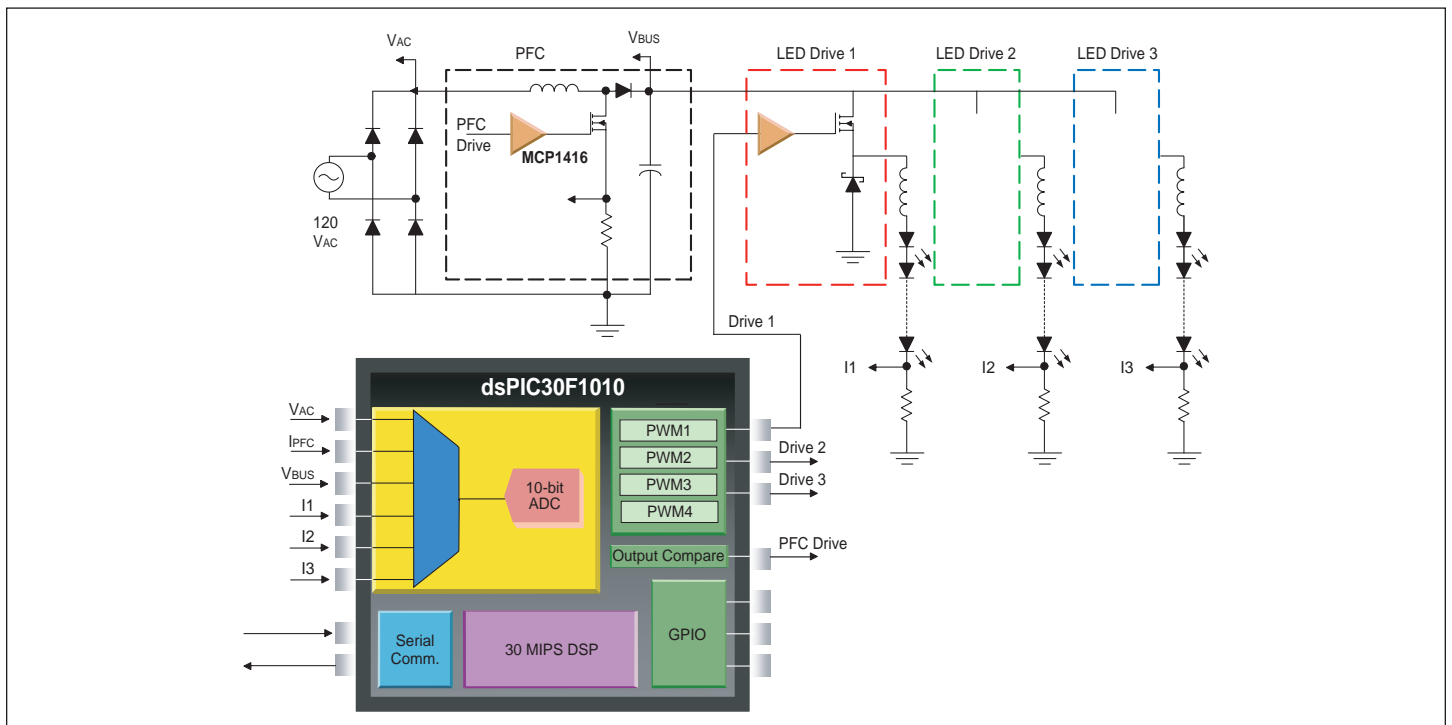

## Wired Communication Solutions for Lighting

Many lighting applications require some form of communication for remote control but also for diagnostic purposes. Some of the most common interfaces used in lighting are:

- 0-10V
- DMX512
- Digitally Addressable Lighting Interface (DALI)

### 0-10V Interface

All PIC microcontroller families offer models that integrate an Analog-to-Digital converter peripheral with a minimum of 8-bit resolution that allows them to connect to the industry standard 0-10V interface with minimum external component count. Most Flash PIC microcontroller models offer a 10-bit resolution ADC, while 12-bit resolution is available on selected models. Each I/O pin is protected by a pair of (clipping) diodes so to prevent latch-up and damages that could follow from the incorrect wiring of a 0-10V interface (over-voltage).

There are different 0-10V specifications based on the intended application. The 0-10V control interface for controllable ballasts is defined in Annex E of the IEC60929 specification. The 0-10V control interface for the entertainment industry is defined by ANSI E1.3-2001.

### 0-10V Dimmable Ballast Interface

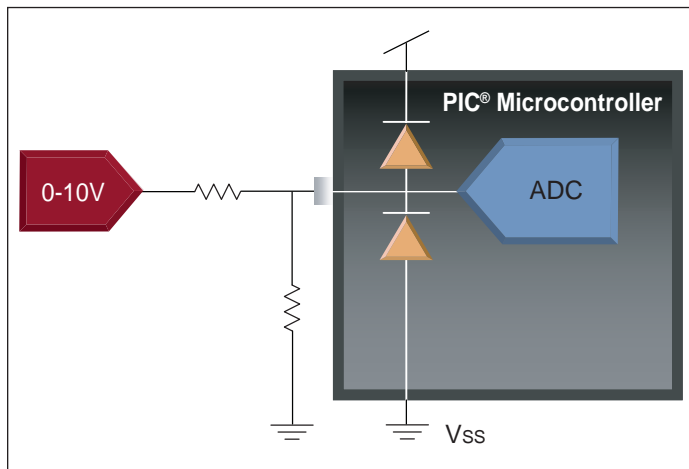

## DMX512

The DMX512 interface (ANSI E1.11) has gained great popularity in theatrical/entertainment lighting applications because of its simplicity and low cost. It is based on a 250 Kbaud asynchronous serial interface that uses the standard RS-485 differential line transceivers. Transmitter and receivers can be implemented on most PIC microcontrollers in a few lines of code. PIC microcontrollers that offer a EUSART peripheral allow for the simplest and most efficient implementation of the protocol.

Application note AN1076 offers an example implementation of both a transmitter and typical DMX512 receiver on a PIC18F2420 model.

The figure below shows an application example where a PIC18F1330 implements a DMX512 receiver to control three PWM output channels (each capable of 14-bit resolution).

### Literature on the Web

- AN1076 – Using a PIC Microcontroller for DMX512 Communication

### PIC18F1330 Controlling 3 PWM Output Channels

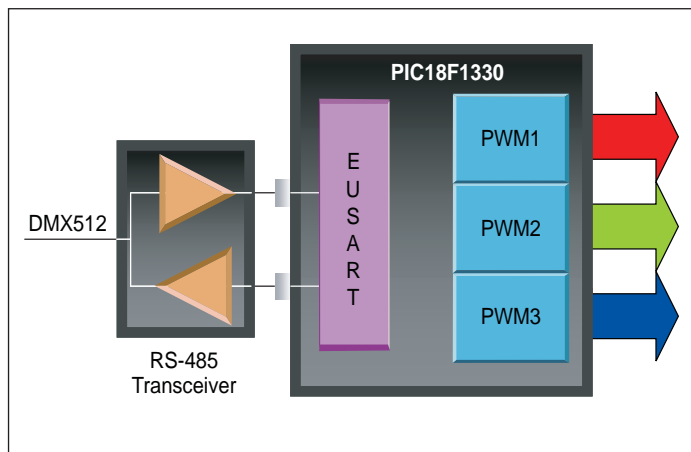

### Digitally Addressable Lighting Interface (DALI)

DALI is a bi-directional digital protocol that requires a two wire connection system similar to the 0-10V interface, but offers individual lamp or group addressability in a bus configuration. The low speed Manchester encoding system used allows for an inexpensive firmware implementation on most any PIC microcontroller. Further many PIC devices offering an analog comparator peripheral can implement an advanced power savings technique as demonstrated in application note AN809. Application note AN811 illustrates the implementation of a bridge between DALI and a standard RS-232 serial interface.

### DALI Ballast Software Library

A DALI ballast software library is available for PIC MCUs that comply with the latest release of the IEC60929 specification. Contact your local sales office for availability.

### Literature on the Web

- AN809 – Digitally Addressable DALI Dimming Ballast
- AN811 – The RS-232/DALI Bridge Interface

### Low Power DALI Interface

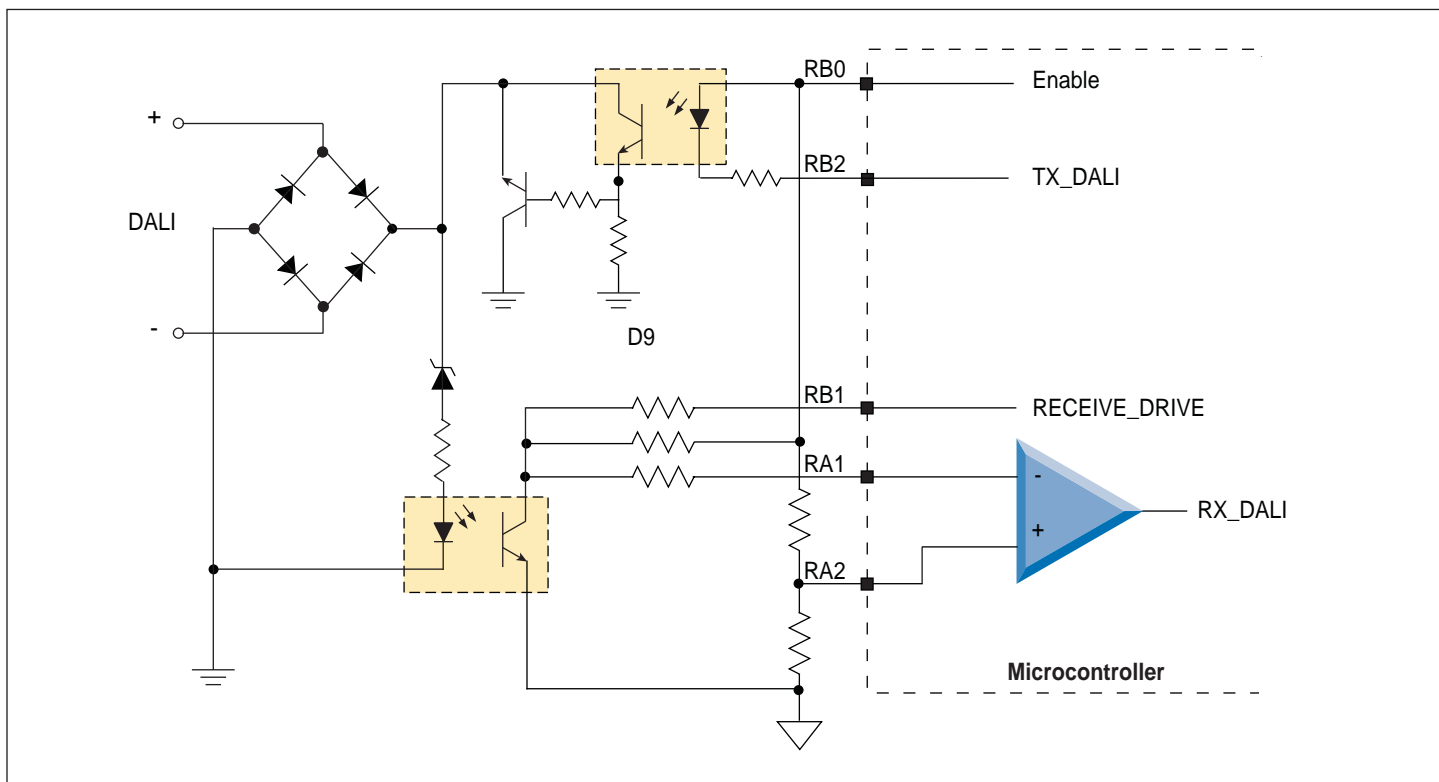

## Advanced Communication Solutions for Lighting

Several advanced wired and wireless communication interfaces are being evaluated for use in a multitude of innovative lighting applications including:

- ZigBee® and MiWi™ wireless protocols based on the IEEE 802.15.4 standard
- Ethernet, IEEE 802.3
- USB
- CAN, LIN

### ZigBee® Protocol

The ZigBee protocol is an industry standard protocol for wireless networking. Specifically designed for low cost and



relatively low bandwidth automation applications it allows the quick deployment of several networking flexible topologies, including star, cluster and mesh. The PIC18F family of microcontrollers offers the ideal combination of performance and

low power features required to implement an efficient ZigBee solution. Application note AN965 offers a free ZigBee stack implementation for the PIC18F family of microcontrollers.

### MiWi™ Protocol

To further reduce the cost of implementation of a typical node in a small (max 4000 nodes) wireless network, Microchip is offering MiWi, a free networking protocol optimized for the smallest firmware footprint.

### Wireless Tools

MRF24J10 – a fully integrated 2.4 GHz IEEE 802.15.4 compatible transceiver

DM163027-4 – PICDEM Z 2.4 GHz Demonstration Kit

DM183023 – ZENA™ wireless network analyzer tool uses a simple graphical interface to configure the free Microchip ZigBee and MiWi protocol stacks.

### Web Links

- [www.microchip.com/wireless](http://www.microchip.com/wireless)
- [www.microchip.com/zigbee](http://www.microchip.com/zigbee)
- [www.microchip.com/miwi](http://www.microchip.com/miwi)

## Ethernet Interface

Ethernet (10baseT) connectivity is becoming ubiquitous and most new office and industrial building are being wired for Ethernet. As lower cost solutions are becoming available it is increasingly tempting to use Ethernet for even the simplest control and diagnostic applications.

### Ethernet Interface Controller

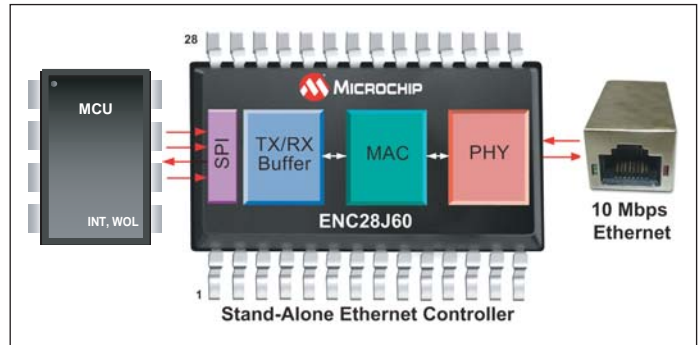

In particular Microchip makes available three solutions that simplify greatly the design of any Ethernet interface:

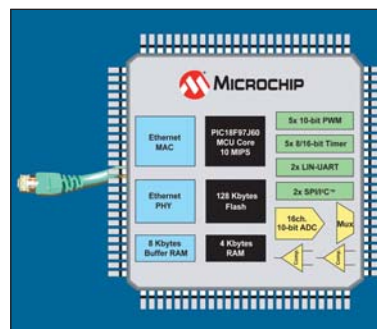

- ENC28J60 Ethernet interface controllers, incorporating MAC and PHY interfaces, connecting with any PIC microcontroller via a simple SPI interface
- PIC18F97J60 family of high performance 8-bit microcontrollers (from 32 Kbytes to 128 Kbytes of Flash) with integrated Ethernet interface

- Free TCP/IP stack, complete but modular software stack that implements all the protocol layers in a very small memory space

### Development Tools

DM163024 – PICDEM.net™ 2 Development Board

AC164123 – Ethernet PICtail™ Plus Daughter Board

AC164121 – Ethernet PICtail™ Daughter Board

DM240001 – Explorer 16 Development Board

### Web Links

For complete Ethernet support, including a free software library, application notes and demonstration boards, visit: [www.microchip.com/ethernet](http://www.microchip.com/ethernet)

### USB Interface

With the demise of the serial port, any application that requires a connection with a personal computer has now to be routed to the USB port. Some innovative lighting applications occasionally require such a connection to be established. Several models of PIC18F microcontrollers incorporate a complete USB interface. Several interface examples are offered to the designer to simplify the transition from serial port to USB and to integrate the application with existing Microsoft Windows® drivers.

#### PICDEM™ FS-USB Demonstration Board



### Development Tools

DM163025 – PICDEM FS-USB Demonstration Board

DM320003 – PIC32 USB Starter Board

### Web Link

For complete USB support, including a free software library, application notes and demonstration boards, visit: [www.microchip.com/usb](http://www.microchip.com/usb)

### CAN and LIN Protocols

Both the CAN and LIN protocols were originally created for the automotive market. CAN was designed as a high reliability and speed protocol (up to 1 Mbit/s) for the harsh environment of the car electrical bus. LIN was later added as a simple low cost alternative for the control of non critical modules on a vehicle. Both find occasional application in lighting.

The PIC18F family of 8-bit microcontrollers includes several models (from 16 Kbytes to 96 Kbytes of Flash) with a complete CAN serial interface. The MCP25XX series of peripheral interfaces includes several CAN transceiver and CAN I/O expander devices.

#### PICDEM™ LIN Demonstration Boards



All PIC microcontroller devices offering an EUSART module (PIC18F devices and most recent PIC16F devices) offer direct support for LIN bus connectivity with auto-baud rate detection and specific low power features.

### Development Tools

DM163005 – PICDEM LIN Demonstration Board

DM163011 – PICDEM CAN-LIN 2 Demonstration Board

APGDT001 – LIN Serial Analyzer Tool

APGRD004 – Ref Design, Automotive Ambient Lighting

### Literature on the Web

- AN829 – LightKeeper Automotive Lighting Control Module, DS00829

### Web Links

[www.microchip.com/can](http://www.microchip.com/can)

[www.microchip.com/lin](http://www.microchip.com/lin)



## Temperature Sensing Solutions for Power LED Applications

Every light source has a specific energy efficiency. A certain portion of the energy supplied to it is wasted in the form of heat. One of the fundamental differences between Power LED technology and other traditional sources of light is in the way this heat is transferred. In fact, LEDs are particularly good at producing a radiation with very narrow range of frequencies typically designed to produce a specific color in the visible spectrum. There is very little infrared (heat) radiation produced. All the heat produced by the light source has to be transferred instead by contact. Packaging technology plays an important role in facilitating the heat transfer from the LED, but an accurate thermal analysis of the entire lighting application (total thermal resistance from junction to ambient) is required to guarantee that the maximum temperature of the junction is not exceeded during operation. In particular, white LEDs employ phosphor materials to convert the monochromatic light emitted into a wider spectrum, to produce a “white” color. The phosphors are even more sensitive to temperature and can be easily damaged if overheated.

Before the LED junction reaches the maximum operating junction temperature (typically 125°C) the temperature increase will have negative impact on a number of LED characteristics including efficiency, light intensity, lifetime and color.

While the safe way to design a power LED application is to provide a low temperature resistance path to a heat sink that is dimensioned for the worst possible environmental and usage conditions, this might not always be possible for physical or cost constraints. For this reason driver ICs used in LED applications (such as the MCP1630 and MCP1650) often incorporate an over-temperature protection, performing what is substantially a device shutdown when the temperature rises above a given threshold. While this is effective to protect the device from reaching temperatures that could damage the LED (or the phosphor layer for white LED applications), the driver IC is not always guaranteed to be placed close to the emitting device(s). If the LEDs are arranged in modules, separate from the driving circuit, comprising several emitters connected in series or parallel, the temperature sensed by the driver could be considerably different from the actual module emitter’s junctions.

## Logic Output Temperature Sensors

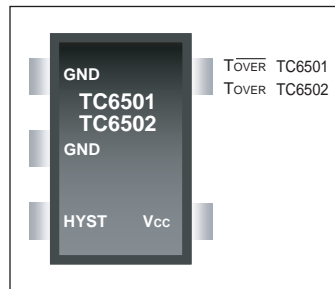

Low cost temperature sensing devices such as the TC6501 and TC6502 (offered in SOT-23 packages) can be conveniently placed near power LED(s) to obtain a more accurate temperature monitoring and provide a logic output fault signal.

The fault signal will be activated as soon as a factory-programmed temperature threshold is reached. Temperature threshold values can be selected in increments of 20°C as indicated in the following table.

### TC6501/TC6502 Logic Output Temperature Sensors

| Device         | Marking Code | Temperature Threshold (°C) |
|----------------|--------------|----------------------------|
| TC6501P045VCT  | HA           | 45                         |
| TC6501P065VCT  | HC           | 65                         |
| TC6501P075VCT  | HD           | 75                         |
| TC6501P095VCT  | HF           | 95                         |
| TC6501P0105VCT | HG           | 105                        |
| TC6501P0115VCT | HH           | 115                        |
| TC6501P0120VCT | HV           | 120                        |
| TC6501P0125VCT | HJ           | 125                        |

### Using TC6501 Open Drain Output for Current Set-Point Control

There are different ways that the TC6501 and TC6502 temperature sensors can be used in an application. The open-drain output of the TC6501 is useful for controlling signals in analog circuits. For example, the TC6501 could be used to limit a current reference set-point for a switch-mode power supply. It could also be connected to signals in op amp circuits to alter the behavior of the system when a temperature limit is exceeded (see figure below).

### Using the TC6501 to Provide MCU Interrupt

If a microcontroller is present and managing the application, a TC6502 with CMOS active-high output signal can be used to provide an interrupt. The microcontroller in turn will be able to apply PWM dimming techniques to reduce the power output to the module (as shown in figure below).

### Fan Controller Application Using TC6502

If a cooling device (fan) is available, a TC6502 device (with the HYST pin connected to Vcc to obtain a 10°C hysteresis threshold) can directly control a cooling fan to improve the heat transfer.

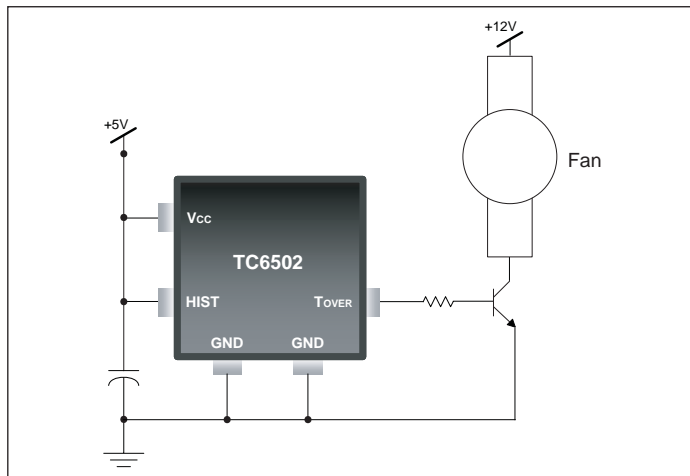

### Using TC6501 Open Drain Output for Current Set-Point Control

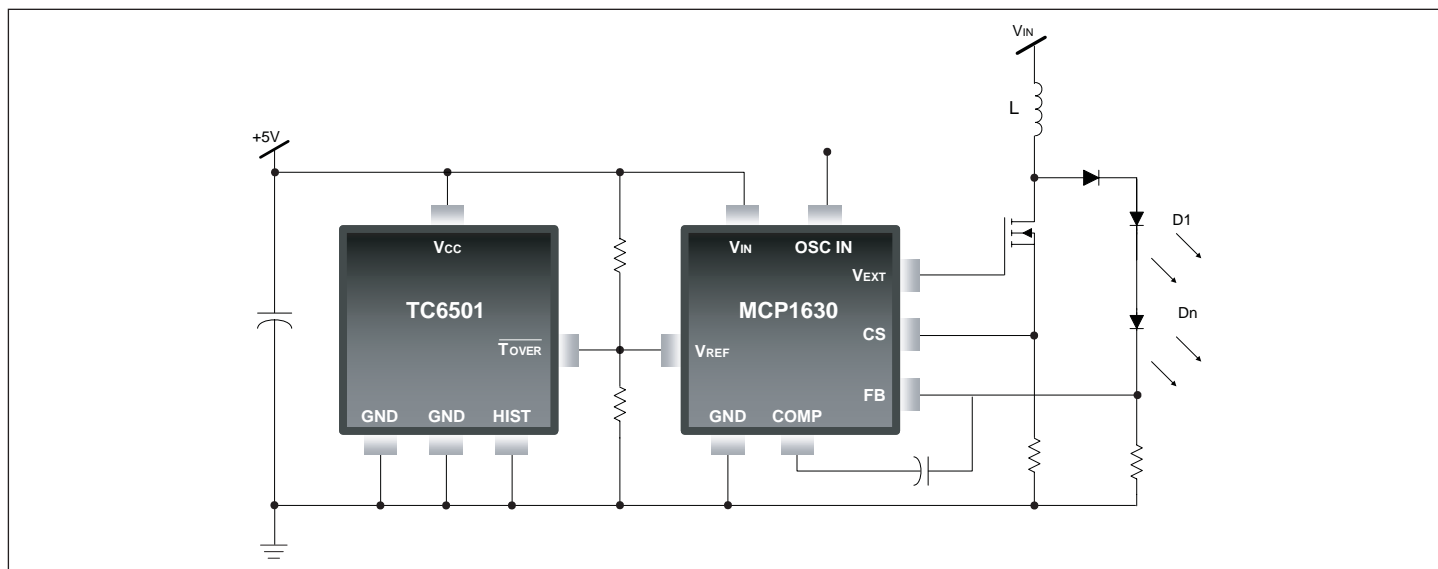

### Using the TC6501 to Provide MCU Interrupt

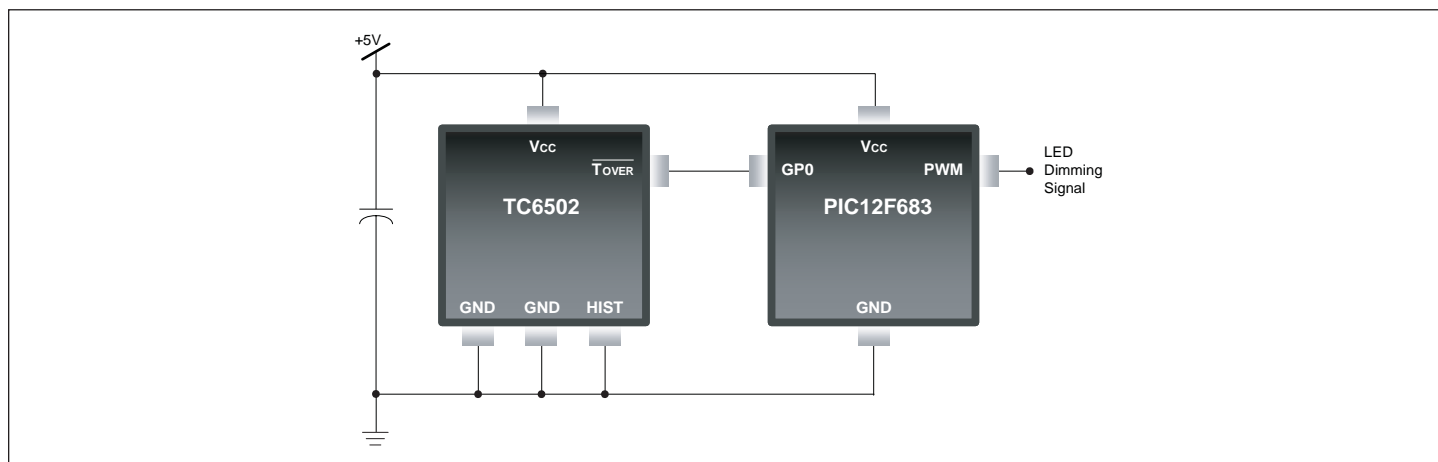

## Voltage Output Temperature Sensors

The most basic technique employed to protect the device from damaging over-temperature conditions is to provide a shutdown signal to the driver circuit when a pre-defined threshold is reached. However, this behavior can be unacceptable in applications where continuous lighting is required for safety or regulatory conditions. A more advanced approach can be obtained if a microcontroller is used to manage the lighting application providing closed loop control of the power supplied by the driver circuit. As the temperature approaches the threshold the current supplied can be reduced to limit the power output.

By using a Voltage Output Temperature Sensor such as the MCP9700 and MCP9701, placed on the LED module close to the emitting device, it is possible to provide a linear voltage feedback signal to a PIC microcontroller. This solution ensures that the light source can always operate at a power level that remains within temperature limits. Almost any kind of software algorithm can be implemented in the microcontroller to respond to the temperature feedback, allowing tremendous flexibility.

### MCP9700/01 Voltage Output Temperature Sensors

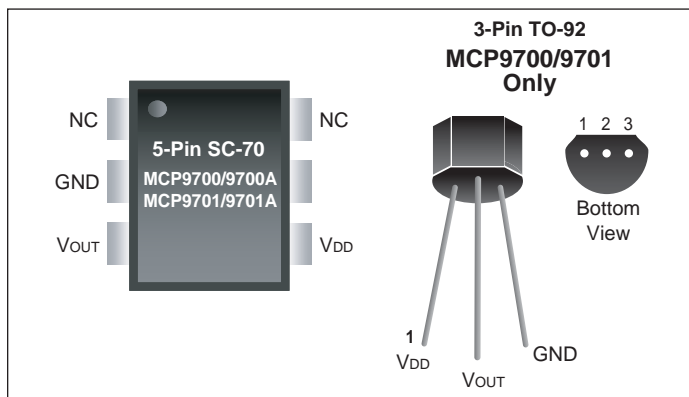

## Using the MCP9700 to Control Current Set-Point of the MCP1630

The voltage output of the MCP9700 temperature sensor can be directly connected to one of the analog to digital converter inputs of a PIC microcontroller to provide a linear indication of the temperature of the LED module.

The following application schematic illustrates the use of an MCP1630 switch mode DC-DC converter as a current controlled source to drive a power LED module. The voltage output of the MCP9700/1 temperature sensor is directly connected to the microcontroller Analog-to-Digital converter input. The MCP9700/1 temperature coefficients are scaled to provide 1°C/bit resolution for an 8-bit ADC with a reference voltage of 2.5V and 5V respectively. The PWM output (CCP1) of the microcontroller, connected to a small low pass (RC) filter, is used to produce the reference signal for the MCP1630 converter to control the output current set point. A few lines of software can be used to control the current output so to conform to the LED maximum current specifications (function of the measured LED module temperature see figure below).

### Using the MCP9700 to Control Current Set-Point of the MCP1630

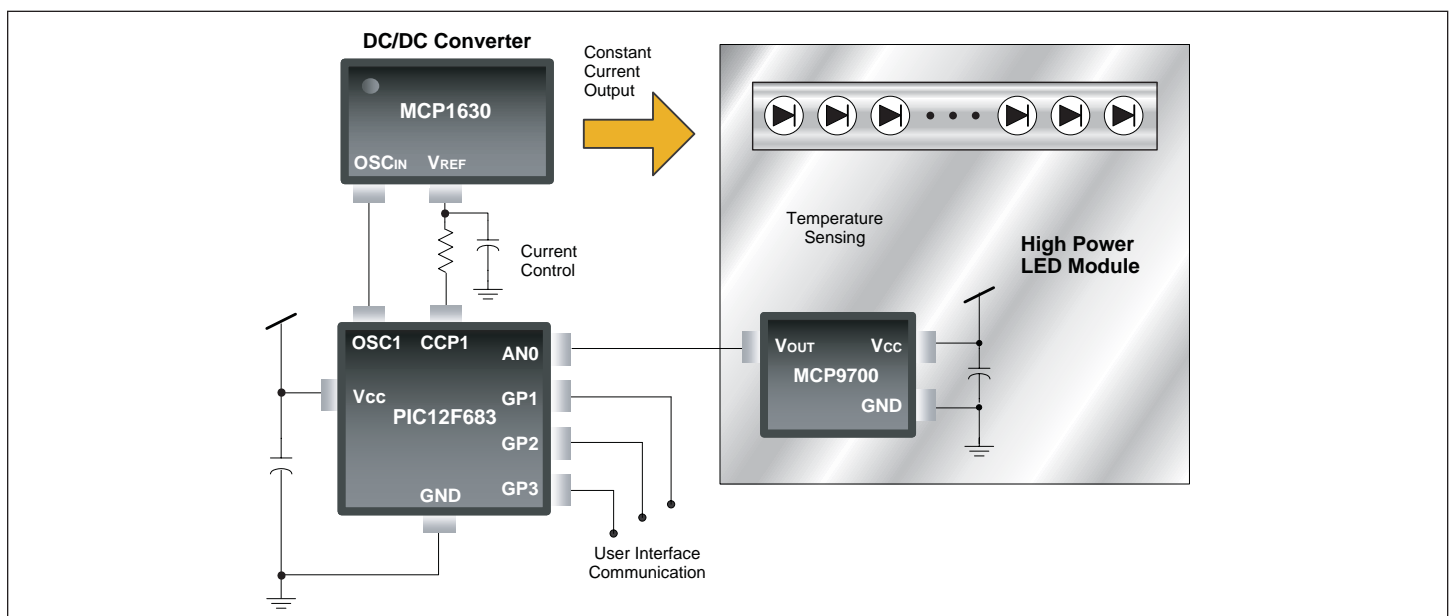

## Power LED Thermal Control Circuit Using MCP9700 and MCP1650

Alternatively a PIC microcontroller can perform a direct PWM control (on/off) of the entire LED driving circuit at low frequency (100-120 Hz). By limiting the average on-time of the power LED, the total power output can be limited. This technique has the advantage of stabilizing the application temperature while maintaining the LED driving current constant therefore limiting the LED color shift produced by forward current changes. The diagram below illustrates an example of a switching DC-DC converter design based on the MCP1650 boost regulator controlled by a 6-pin PIC10F220 microcontroller.

## Learn More

The Intelligent Power Supply Design Center ([www.microchip.com/power](http://www.microchip.com/power)) features temperature sensing solutions, including application notes and product selection charts.

## Literature on the Web

- DG4 – Temperature Sensor Design Guide, DS21895

## Power LED Thermal Control Circuit Using MCP9700 and MCP1650

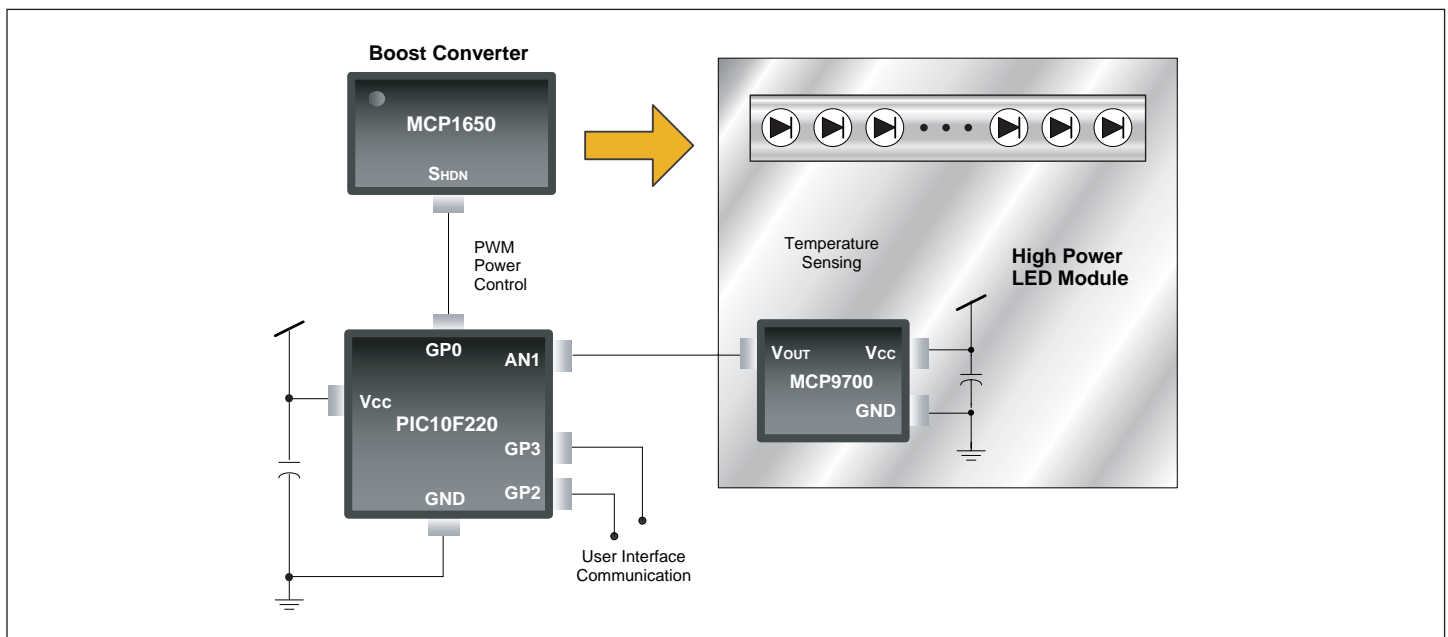

### Getting Started

The Microchip web site ([www.microchip.com](http://www.microchip.com)) provides a wealth of information that can help you get started with your lighting design.

### Lighting Design Center

If you would like more information about any of the solutions presented here, please visit the Microchip Lighting Design Center ([www.microchip.com/lighting](http://www.microchip.com/lighting)) for further details. The Lighting Design Center contains links to application notes, user manuals and software for many of the solutions referenced in this brochure.

### Start Now

If you are not familiar with Microchip's products or microcontroller technology, you may want to visit [www.microchip.com/startnow](http://www.microchip.com/startnow). These pages on the Microchip website provide more information about our products in the PIC10F, PIC12F and PIC16F MCU device families. These pages will also help you select the right development tools to get the design process started.

### Intermediate Solutions

The PIC18F MCU device family offers high-performance 8-bit solutions for embedded control. The PIC18F devices offer faster calculation performance and more on-chip memory. These features are helpful if you need digital control or support for communication protocols. See [www.microchip.com/pic18](http://www.microchip.com/pic18) for more information.

### Full Digital Control

If you are interested in full digital control for LED drivers, you may want to see Microchip's 16-bit solutions. To learn more, visit [www.microchip.com/16-bit](http://www.microchip.com/16-bit).

### Analog

Visit [www.microchip.com/analog](http://www.microchip.com/analog) to see all of Microchip's analog and interface product offerings. These products include DC-DC converters that are useful in LED driver applications.

### Development Tools

Visit [www.microchip.com/tools](http://www.microchip.com/tools) to learn more about all of Microchip's software and hardware development tools.

### Webinars

Microchip Webinars provide technical training on your schedule 24 hours a day, 7 days a week. More than 75 presentations are available on the Microchip web site with both audio and visual training elements to make learning even easier. These short training modules have become very popular with designers. Visit [www.microchip.com/webseminars](http://www.microchip.com/webseminars) for a complete list of classes.

### Regional Training Centers

To meet customers' demands for more training more often, Microchip has established a global network of Regional Training Centers (RTCs) that provide workshops and seminars on a year-round basis. Each RTC offers a variety of courses on a regular basis to fit with your demanding schedule. You can benefit by learning in small hands-on classroom settings that focus on your specific needs. Visit [www.microchip.com/RTC](http://www.microchip.com/RTC) for the latest list of RTC locations and classes.

### Support

If you need quick answers to your technical questions, please contact our Technical Support site 24 hours a day, 7 days a week at <http://support.microchip.com>. In addition Microchip has a growing number of field applications support personnel in your area that can work with you on your individual needs. For more information, please contact your nearest Microchip sales office listed on the back cover.

### Third-Party Design Resources

If you require assistance with your product design, Microchip has many third-party resources to help you. These resources include a large selection of consultants that are screened by Microchip and rated based on the number of Microchip designs. You can find a list of these consultants, resumes and ratings on the Microchip web site at [www.microchip.com/partners](http://www.microchip.com/partners).

### Samples

Free evaluation samples of any Microchip device can be obtained at <http://sample.microchip.com>.

### Purchase

MicrochipDIRECT is a web-based purchasing site that gives you 24 hour a day access to all Microchip devices and tools, including pricing, ordering, inventory and support. You can buy all the products you need on a easily opened Microchip line of credit. Visit [www.microchipdirect.com](http://www.microchipdirect.com) for more information.

### Solid State Lighting Questions?

Submit questions or comments to [lighting@microchip.com](mailto:lighting@microchip.com)



## Support

Microchip is committed to supporting its customers in developing products faster and more efficiently. We maintain a worldwide network of field applications engineers and technical support ready to provide product and system assistance. In addition, the following service areas are available at [www.microchip.com](http://www.microchip.com):

- **Support** link provides a way to get questions answered fast: <http://support.microchip.com>
- **Sample** link offers free evaluation samples of any Microchip device: <http://sample.microchip.com>
- **Training** link offers webinars, registration for local seminars/workshops and information on annual MASTERS events held throughout the world: [www.microchip.com/training](http://www.microchip.com/training)
- **Forum** link provides access to knowledge base and peer help: <http://forum.microchip.com>

## Sales Office Listing

### AMERICAS

#### Atlanta

Tel: 678-957-9614

#### Boston

Tel: 774-760-0087

#### Chicago

Tel: 630-285-0071

#### Cleveland

Tel: 216-447-0464

#### Dallas

Tel: 972-818-7423

#### Detroit

Tel: 248-538-2250

#### Kokomo

Tel: 765-864-8360

#### Los Angeles

Tel: 949-462-9523

#### Santa Clara

Tel: 408-961-6444

#### Toronto

Mississauga, Ontario

Tel: 905-673-0699

### EUROPE

#### Austria - Wels

Tel: 43-7242-2244-39

#### Denmark - Copenhagen

Tel: 45-4450-2828

#### France - Paris

Tel: 33-1-69-53-63-20

#### Germany - Munich

Tel: 49-89-627-144-0

#### Italy - Milan

Tel: 39-0331-742611

#### Netherlands - Druun

Tel: 31-416-690399

#### Spain - Madrid

Tel: 34-91-708-08-90

#### UK - Wokingham

Tel: 44-118-921-5869

## Purchase



microchipDIRECT is a web-based purchasing site that gives you 24-hour-a-day access to all Microchip devices and

tools, including pricing, ordering, inventory and support. You can buy the products you need on an easily opened Microchip line of credit.

### ASIA/PACIFIC

#### Australia - Sydney

Tel: 61-2-9868-6733

#### China - Beijing

Tel: 86-10-8528-2100

#### China - Chengdu

Tel: 86-28-8665-5511

#### China - Hong Kong SAR

Tel: 852-2401-1200

#### China - Nanjing

Tel: 86-25-8473-2460

#### China - Qingdao

Tel: 86-532-8502-7355

#### China - Shanghai

Tel: 86-21-5407-5533

#### China - Shenyang

Tel: 86-24-2334-2829

#### China - Shenzhen

Tel: 86-755-8203-2660

#### China - Wuhan

Tel: 86-27-5980-5300

#### China - Xiamen

Tel: 86-592-2388138

#### China - Xian

Tel: 86-29-8833-7252

#### China - Zhuhai

Tel: 86-756-3210040

### ASIA/PACIFIC

#### India - Bangalore

Tel: 91-80-4182-8400

#### India - New Delhi

Tel: 91-11-4160-8631

#### India - Pune

Tel: 91-20-2566-1512

#### Japan - Yokohama

Tel: 81-45-471- 6166

#### Korea - Daegu

Tel: 82-53-744-4301

#### Korea - Seoul

Tel: 82-2-554-7200

#### Malaysia - Kuala Lumpur

Tel: 60-3-6201-9857

#### Malaysia - Penang

Tel: 60-4-227-8870

#### Philippines - Manila

Tel: 63-2-634-9065

#### Singapore

Tel: 65-6334-8870

#### Taiwan - Hsin Chu

Tel: 886-3-572-9526

#### Taiwan - Kaohsiung

Tel: 886-7-536-4818

#### Taiwan - Taipei

Tel: 886-2-2500-6610

#### Thailand - Bangkok

Tel: 66-2-694-1351

1/2/08



**MICROCHIP**  
[www.microchip.com/lighting](http://www.microchip.com/lighting)

Microchip Technology Inc. • 2355 W. Chandler Blvd. • Chandler, AZ 85224-6199

**Microcontrollers • Digital Signal Controllers • Analog • Serial EEPROMs**

The Microchip name and logo, the Microchip logo, MPLAB, PIC and PICmicro are registered trademarks of Microchip Technology Incorporated in the U.S.A. and other countries. MiWi, PICDEM, PICDEM.net, PICtail and ZENA are trademarks of Microchip Technology Incorporated in the U.S.A. and other countries. All other trademarks mentioned herein are property of their respective companies.

© 2008, Microchip Technology Incorporated, All Rights Reserved. Printed in the U.S.A. 9/08

DS01036D

