

MAXIM

MAX9760/MAX9761 Evaluation System/Evaluation Kit

General Description

The MAX9760 evaluation system (EV system) consists of a MAX9760 evaluation kit (EV kit) and a companion Maxim System Management Bus (SMBus™) interface board. The MAX9760 EV kit is also capable of evaluating the MAX9761/MAX9762/MAX9763.

The MAX9760 EV kit is a fully assembled and tested surface-mount circuit board that evaluates the MAX9760 3W stereo audio power amplifier plus headphone driver. The EV kit is designed to be driven by any stereo audio source such as a CD player. The EV kit includes RCA jacks on the inputs, a 3.5mm headphone jack, and terminal blocks on the outputs to facilitate easy connections to the circuit board. The EV kit includes Windows®98/2000/XP-compatible software, which provides a user interface for exercising the MAX9760's features.

The Maxim SMBus interface board (MAXSMBUS) allows an IBM-compatible PC to use its parallel port to emulate an SMBus/I²C 2-wire interface. Windows 98/2000/XP-compatible software provides a user-friendly interface to exercise the MAX9760 features. The program is menu driven and offers a graphical user interface (GUI) with control buttons and a status display.

The MAX9760EVSYS includes both the EV kit and the MAXSMBUS interface board. Order the MAX9760EVKIT if you already have an SMBus interface. The MAX9761 EV kit functions as a stand-alone unit, the MAXSMBUS interface is not required.

SMBus is a trademark of Intel Corp.

Windows is a registered trademark of Microsoft Corp.

Ordering Information

PART	TEMP RANGE	IC PACKAGE	SMBus INTERFACE TYPE
MAX9760EVKIT	0°C to +70°C	28 QFN	Not included
MAX9760EVSYS	0°C to +70°C	28 QFN	MAXSMBUS
MAX9761EVKIT	0°C to +70°C	28 QFN	Not required

Note: To evaluate the MAX9762, or MAX9763, request a MAX9762ETI or MAX9763ETI free sample with the MAX9760EVKIT. To evaluate the MAX9761, order the MAX9761EVKIT. The MAX9760 EV kit software is provided with the MAX9760EVKIT; however, the MAXSMBUS board is required to interface the EV kit to the computer when using the included software.

Features

- ◆ 4.5V to 5.5V Single-Supply Operation
- ◆ 3W Stereo Bridge-Tied-Load (BTL) Amplifier
- ◆ 100dB Power-Supply Rejection Ratio
- ◆ SMBus/I²C-Compatible 2-Wire Serial Interface
- ◆ 2:1 Stereo Input MUX
- ◆ Selectable Bass-Boost Circuitry
- ◆ No Detectable Clicks or Pops
- ◆ Easy-to-Use, Menu-Driven Software
- ◆ Assembled and Tested
- ◆ Software-Controlled Mute, Shutdown, Input Selection, and Gain
- ◆ Automatic Headphone-Sensing Circuitry
- ◆ Includes Windows 98/2000/XP-Compatible Software and Demo PC Board
- ◆ Evaluates the MAX9760–MAX9763

Block Diagram

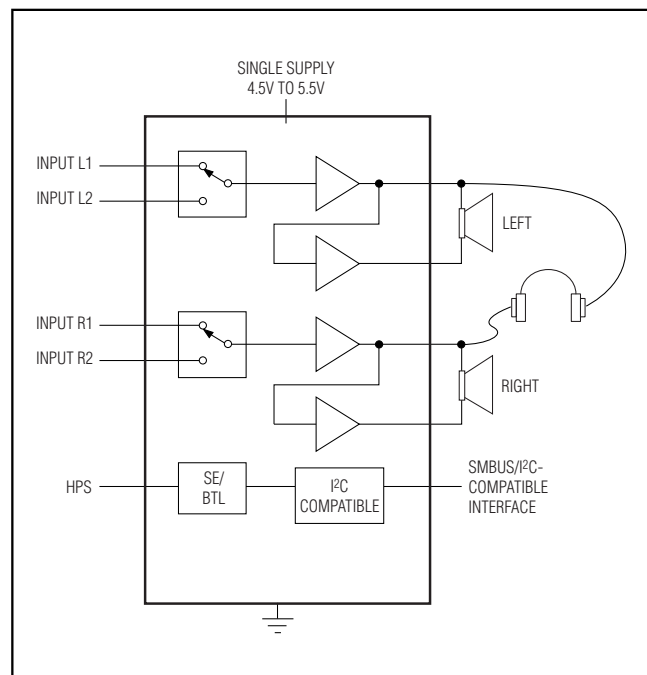

Figure 1. MAX9760/61 EV Kit Block Diagram

Evaluates: MAX9760—MAX9763

MAX9760/MAX9761 Evaluation System/Evaluation Kit

Component List

DESIGNATION	QTY	DESCRIPTION
C1–C4	4	0.68 μ F \pm 10%, 20V tantalum capacitors (R-case) AVX TAJR684K020
C5, C6, C16	3	100pF \pm 5%, 50V C0G ceramic capacitors (0402) TDK C1005C0G1H101J
C7, C8	2	0.047 μ F \pm 10%, 16V X7R ceramic capacitors (0402) TDK C1005X7R1C473K
C9, C10, C11, C14, C15	5	220 μ F \pm 20%, 6.3V tantalum capacitors (C-case) AVX TPSC227M006R0250
C12, C13	2	1.0 μ F \pm 20%, 10V X7R ceramic capacitors (0603) TDK C1608X7R1A105M
R1–R6, R18	7	15.0k Ω \pm 1% resistors (0402)
R7, R8	2	33.2k Ω \pm 1% resistors (0402)
R9, R10	2	27.4k Ω \pm 1% resistors (0402)
R11, R12, R15, R16	4	10k Ω \pm 5% resistors (0402)

DESIGNATION	QTY	DESCRIPTION
R13, R14	2	1k Ω \pm 5% resistors (0402)
R17	1	680k Ω \pm 5% resistor (0402)
R19	1	47k Ω \pm 5% resistor (0402)
J1, J3	2	Phono jacks, white
J2, J4	2	Phono jacks, red
J5	1	Switched stereo headphone jack (3.5mm dia)
J6	1	2 x 10 right-angle female receptacle
JU1	1	Jumper, dual row, 12-pin header
JU2–JU5	4	3-pin headers
JU6	1	2-pin header
JU7	0	Not installed (SIP-3)
TB1, TB2	2	2-circuit terminal blocks
U1	1	MAX9760ETI (28-pin QFN)
None	6	Shunts
None	1	MAX9760 PC Board
None	1	Software disk (CD-ROM) MAX9760 Evaluation Kit

Component Suppliers

SUPPLIER	PHONE	FAX	WEBSITE
AVX	843-946-0238	843-626-3123	www.avxcorp.com
TDK	847-803-6100	847-390-4405	www.component.tdk.com

Note: Please indicate that you are using the MAX9760 when contacting these component suppliers.

Quick Start

Recommended Equipment

- Computer running Windows 98, 2000, or XP
- Parallel printer port (this is a 25-pin socket on the back of the computer)
- Standard 25-pin, **straight-through**, male-to-female cable (printer extension cable) to connect the computer's parallel port to the Maxim SMBus interface board
- 9V/100mA DC power supply (for the SMBus card)
- 5V/4A DC power supply
- One pair of headphones (16 Ω or greater)
- Two stereo audio sources (to demonstrate the input mux feature)
- One pair of speakers (3 Ω or greater)

Procedure

The MAX9760 EV kit is fully assembled and tested. Follow the steps below to verify board operation. **Do not turn on the power supply until all connections are completed:**

- 1) Carefully connect the boards by aligning the 20-pin connector of the MAX9760 EV kit with the 20-pin header of the MAXSMBUS interface board. Gently press them together.
- 2) Ensure that a shunt is placed across pins 1 and 2 of jumpers JU1, JU4, and JU5.
- 3) Ensure that jumpers JU2 and JU3 do not have a shunt placed on them.
- 4) Ensure that a shunt is installed on jumper JU6.
- 5) Connect a cable from the computer's parallel port to the SMBus interface board. Use a **straight-through**

MAX9760/MAX9761 Evaluation System/Evaluation Kit

25-pin male-to-female cable. To avoid damaging the EV kit or your computer, do not use a 25-pin SCSI port or any other connector that is physically similar to the 25-pin parallel printer port.

- The MAX9760.EXE software program can be run from the CD-ROM or hard drive. Use the Windows program manager to run the program. If desired, you may use the INSTALL.EXE program to copy the files and create icons in the Windows 98/2000/XP **Start** menu.

Do not turn on the power until all connections are made.

- Connect the 9V power supply to the pads labeled POS9 and GND1 of the SMBus interface board.
- Connect the 5.0V power supply to the pads labeled VDD and GND on the MAX9760 EV kit board.

- Ensure that both stereo audio sources are turned off.
- Connect the first stereo audio source to the input jacks labeled J1 and J2.
- Connect the second stereo audio source to the input jacks labeled J3 and J4.
- Plug the headphones into the 3.5mm headphone jack labeled J5.
- Connect the speakers to the terminal blocks labeled TB1 and TB2.
- Turn on the DC power supplies.
- Enable the stereo audio sources.
- Start the MAX9760 program by opening its icon in the **Start** menu.
- Normal device operation can be verified by the SMBus Status: DUT Board Found text in the Interface box.

Evaluates: MAX9760—MAX9763

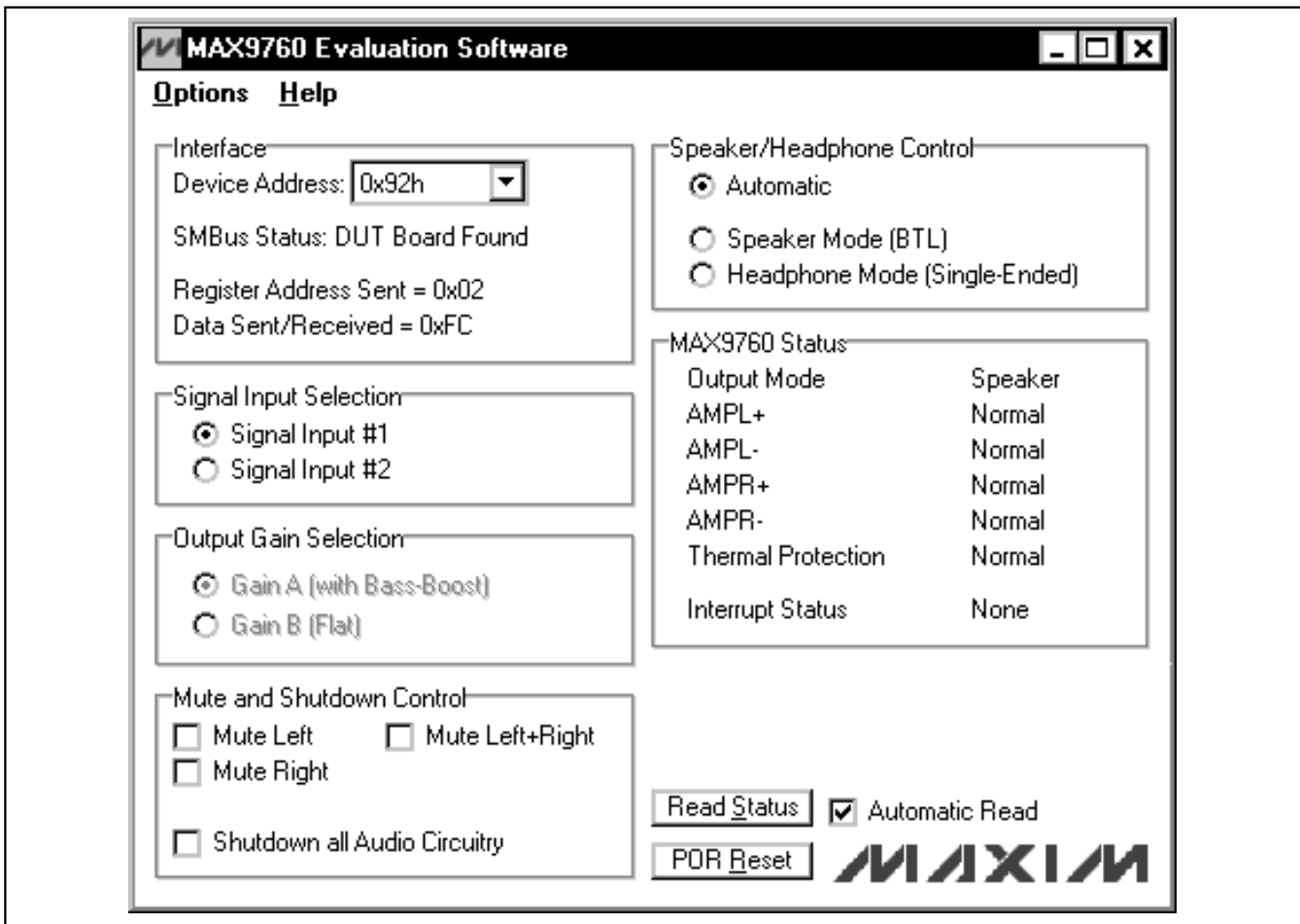

Figure 2. MAX9760 EV Kit Software Main Window

MAX9760/MAX9761 Evaluation System/Evaluation Kit

Detailed Description of Software

User-Interface Panel

The user interface (shown in Figure 2) is easy to operate; use the mouse, or a combination of the Tab and Arrow keys to manipulate the software. Each of the buttons corresponds to bits in the command and configuration bytes. By clicking on them, the correct SMBus write operation is generated to update the internal registers of the MAX9760. The **Interface** box indicates the current **Device Address**, the **Register Address**, and the **Data Sent/Received** for the last read/write operation. This data is used to confirm proper device operation.

Note: Words in boldface are user-selectable features in the software.

Signal Input Selection

The MAX9760 EV kit can route one of two independent stereo signals to the speakers or headphones. The input signal is selected by choosing the desired option in the **Signal Input Selection** box. Choosing **Signal Input #1**, routes the signal from input jacks J1 and J2. Choosing **Signal Input #2**, routes the signal from input jacks J3 and J4.

MAX9760 Status

The program continually polls the device for new status data and monitors the alert conditions. To disable continuous polling of data, uncheck the **Automatic Read** checkbox. If an interrupt condition is generated by the headphones being inserted, the message **INTERRUPT** appears.

Speaker/Headphone Control

Selecting the desired option in the **Speaker/Headphone Control** box allows the MAX9760 EV kit to operate in one of three independent modes. The **Automatic** mode (default) detects the insertion of the headphones in jack J5. The speaker outputs are disabled if the headphones are present, and enabled if the headphones are absent. Selecting the **Speaker Mode (BTL)** provides drive to the speakers and headphones (if both are present). Selecting the **Headphone Mode (Single-Ended)** provides drive to the headphones only.

Software Mute and Shutdown Control

Selecting the desired option in the **Mute and Shutdown Control** box allows the MAX9760 EV kit to disable the left, right, or both output channels. Checking the **Mute Left** option mutes the left channel. Checking the **Mute Right** option mutes the right channel. Checking the **Mute Left+Right** option mutes both channels.

Checking the **Shutdown all Audio Circuitry** places the MAX9760 into a low-power shutdown mode.

Output Gain Selection

Selecting the desired option in the **Output Gain Selection** box allows the MAX9760 EV kit to amplify the chosen input signal using one of two different gains. Selecting **Gain A (with Bass-Boost)** amplifies the input signal using the feedback networks connected to the GAINRA and GAINLA pins of the MAX9760. Selecting **Gain B (Flat)** amplifies the input signal using the feedback networks connected to the GAINRB and GAINLB pins. When the device is in **Automatic** mode, the output gain is dependent on the insertion of the headphones. Refer to the MAX9760–MAX9763 data sheet for more details.

Simple SMBus Commands

There are two methods for communicating with the MAX9760: through the normal user-interface panel or through the SMBus commands available by selecting the **2-Wire Interface Diagnostic** item from the Options pulldown menu. A display pops up that allows the SMBus protocols, such as Read Byte and Write Byte, to be executed. To stop normal user-interface execution so that it does not override the manually set values, turn off the update timer by unchecking the **Automatic Read** checkbox.

The SMBus dialog boxes accept numeric data in binary, decimal, or hexadecimal. Hexadecimal numbers should be prefixed by \$ or 0x. Binary numbers must be exactly eight digits. See Figure 3 for an example of this tool.

Note: In places where the slave address asks for an 8-bit value, it must be the 7-bit slave address of the MAX9760 as determined by ADD with the last bit set to 1 for a read operation or a zero for a write. Refer to the MAX9760 data sheet for a complete list of registers and functions.

Detailed Description of Hardware

The MAX9760 EV kit is a stereo, single-supply speaker/headphone amplifier. The EV kit is designed to be driven by any stereo audio source.

The input impedance is 15k Ω . The EV kit is shipped with components selected to produce a bass-boosted frequency response (6dB, $f_c = 100\text{Hz}$) and a 0dB flat-frequency response. The EV kit is powered with a 4.5V to 5.5V supply. A highpass filter is implemented on the MAX9760 EV kit. The lower 16Hz, -3dB corner frequency is dependent on components R1, R4, and C1, C4, C9, and C10.

Multiple input and output jacks facilitate easy connections to the board. Connect the speakers to terminal blocks TB1 and TB2. Connect the two stereo input sources through jacks J1, J2 and J3, J4. Connect the headphones through jack J5.

MAX9760/MAX9761 Evaluation System/Evaluation Kit

Evaluates: MAX9760—MAX9763

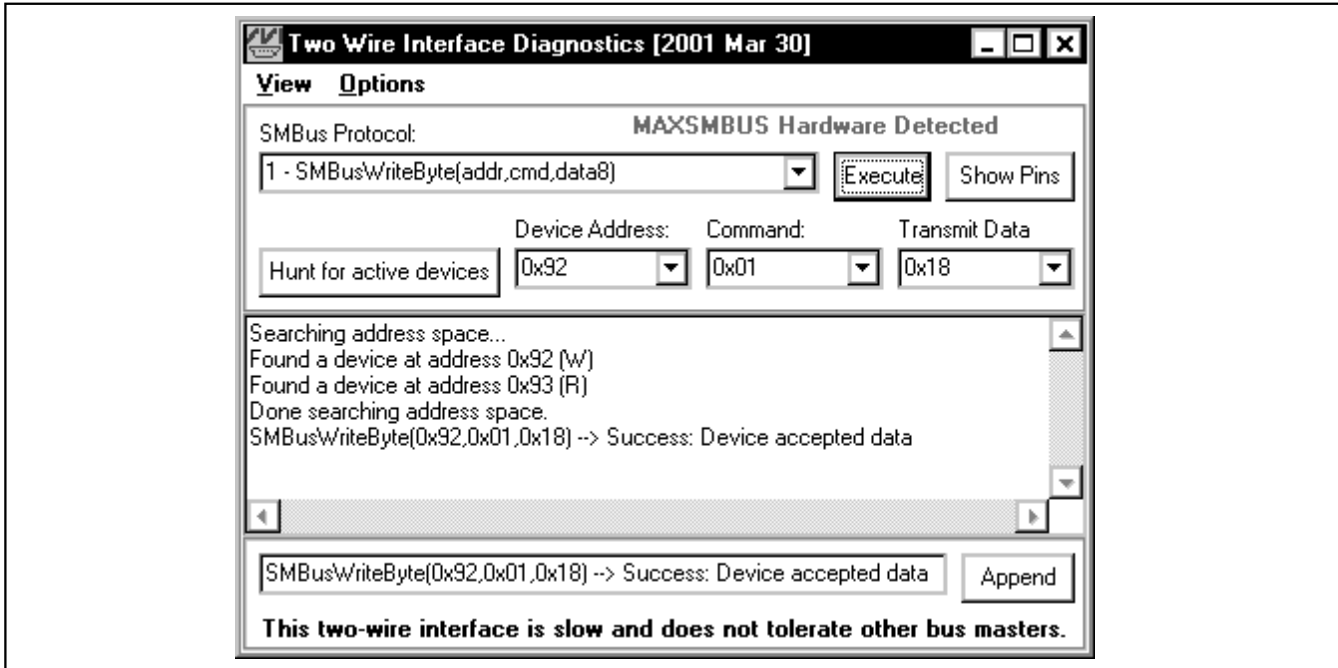

Figure 3. The above example shows a simple SMBusWriteByte operation using the included 2-Wire Interface Diagnostics. In this example, the software is writing data (0x18) to Device Address 0x92, Register Address 0x01. The above data sequence mutes both output channels of the MAX9760.

Address Selection

Jumper JU1 sets the MAX9760 slave address. The default address is 1001 001Y (ADD = VDD). See Table 1 for a complete list of addresses.

Note: The first 7 bits shown are the address. Y (bit 0) is the SMBus read/write bit. This bit is a 1 for a read operation or a zero for a write.

Hardware Shutdown Control

Jumper JU5 controls the shutdown function of the MAX9760 EV kit. Removing the shunt from JU5 allows the shutdown function to be controlled by an external signal source connected to the $\overline{\text{SHDN}}$ pad. See Table 2 for shutdown shunt positions.

Manual Headphone Sense Control

To simulate a pair of headphones being inserted into the headphone jack J5, remove the shunt from jumper JU6. Connect the load to the LEFT, RIGHT, and GND pads located by headphone jack J5 (see Table 3 for jumper settings).

Bass-Boost

The MAX9760 EV kit includes circuitry to increase the low-frequency (bass) response. To alter the bass response (see Figure 4), follow the steps below:

- 1) Choose appropriate gains A_1 and A_2 .
- 2) Choose the center frequency f_c .

Table 1. Shunt Settings for SMBus Address

JUMPER	SHUNT POSITION	MAX9760 ADDRESS PIN	MAX9760 ADDRESS	
			BINARY	HEXADECIMAL
JU1	1–2*	VDD	1001 001Y	0x92
	3–4	SDA	1001 010Y	0x94
	5–6	SGND	1001 000Y	0x90
	7–8	SCL	1001 011Y	0x96
	9–10	Not used for the MAX9760 or the MAX9762 (see the <i>Gain Selection Table</i> for more details).		
	11–12			

*Default configuration.

MAX9760/MAX9761 Evaluation System/Evaluation Kit

3) Calculate and install components R7–R10, C7, and C8 using equations 1, 2, and 3.

$$R_7 = R_8 = 10^{\frac{A_1}{20}} \times 15k\Omega \quad (\text{Eq1})$$

$$R_9 = R_{10} = \frac{R_7 \times 10^{\frac{A_2}{20}} \times 15k\Omega}{R_7 - \left(10^{\frac{A_2}{20}} \times 15k\Omega\right)} \quad (\text{Eq2})$$

$$C_7 = C_8 = \frac{1}{2\pi f_c \sqrt{R_7 \times R_9}} \quad (\text{Eq3})$$

where:

A₁ = bass-boosted gain (dB)

A₂ = nonbass-boosted gain (dB)

f_c = center frequency (Hz).

Evaluating the MAX9761

MAX9761 Shutdown Control

Jumper JU5 controls the shutdown function of the MAX9761. Removing the shunt from JU5 allows the shutdown function to be controlled by an external signal source connected to the SHDN pad. See Table 4 for shutdown shunt positions.

MAX9761 Gain Selection

Jumper JU1 controls the gain selection of the MAX9761. The gain selection function can be set to select gain A or gain B. Alternatively, the gain selection can be controlled by an external signal source through the GAINA/B pad. Gain selection can also be controlled by the headphone sense pin, which enables automatic gain selection. See Table 5 for gain selection shunt positions.

MAX9761 Headphone Sense Enable

Jumper JU4 controls the HPS_EN pin of the MAX9761. Alternatively, the shunt can be removed from JU4 and the HPS_EN pin can be driven by an external signal source connected to the HPS_EN pad. The HPS_EN pin in conjunction with the HPS pin determines the output mode of the MAX9761. Refer to the MAX9760–MAX9763 data sheet for more details. See Table 6 for headphone sense enable shunt positions.

MAX9761 Mute Control

Jumper JU3 controls the Mute function of the MAX9761. Alternatively, the shunt can be removed from JU3 allowing the mute function to be driven by an

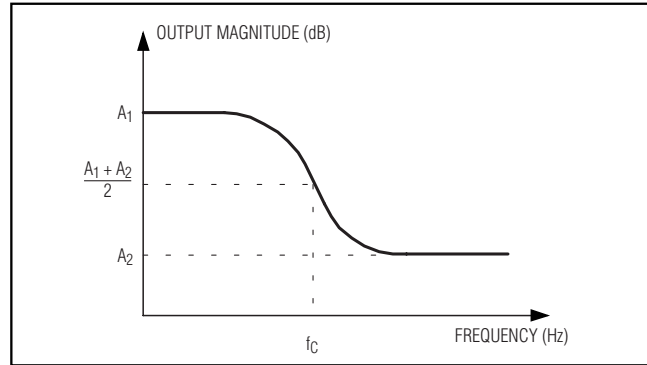

Figure 4. The Bass-Boost Components Create an Output Magnitude Response Similar to the Diagram Shown Above

Table 2. MAX9760 Shutdown Selection

JUMPER	SHUNT POSITION	DESCRIPTION
JU5	1–2*	MAX9760 enabled
	2–3	MAX9760 shut down

*Default configuration.

Table 3. MAX9760 Manual Headphone Sense Control

JUMPER	SHUNT POSITION	DESCRIPTION
JU6	Installed*	MAX9760 EV kit headphone sense controlled by the insertion of headphones
	Not installed	MAX9760 EV kit headphone sense switch forced open

*Default configuration.

Table 4. MAX9761 Shutdown Selection

JUMPER	SHUNT POSITION	DESCRIPTION
JU5	1–2*	MAX9761 enabled
	2–3	MAX9761 shutdown
	Not installed	SHDN function controlled by an external signal source

*Default configuration.

external signal source connected to the MUTE pad. See Table 7 for mute shunt positions.

MAX9760/MAX9761 Evaluation System/Evaluation Kit

Table 5. MAX9761 Gain Selection

JUMPER	SHUNT POSITION	MAX9761 GAIN \bar{A} /B PIN	DESCRIPTION
JU1	1–2*	VDD	Gain B selected
	3–4	SDA	Not valid
	5–6	DGND	Gain A selected
	7–8	SCL	Not valid
	9–10	GAIN \bar{A} /B pad	Gain selection controlled by an external signal source
	11–12	HPS pin of MAX9761	Automatic gain selection mode

*Default configuration.

Table 6. MAX9761 Headphone Sense Enable Selection

JUMPER	SHUNT POSITION	DESCRIPTION
JU4	1–2*	HPS_EN pin tied high
	2–3	HPS_EN pin tied low
	Not installed	HPS_EN pin controlled by an external signal source

*Default configuration.

Table 7. MAX9761 Mute Control

JUMPER	SHUNT POSITION	DESCRIPTION
JU3	1–2	Output disabled
	2–3*	Output enabled
	Not installed	Mute function controlled by an external signal source

*Default configuration.

Table 8. MAX9761 Input Selection

JUMPER	SHUNT POSITION	DESCRIPTION
JU2	1–2	Input 2 selected
	2–3*	Input 1 selected
	Not installed	Input selection controlled by an external signal source

*Default configuration.

MAX9761 Input Selection

Jumper JU2 controls the input selection function of the MAX9761. Alternatively, the shunt can be removed from JU2 allowing the input selection function to be driven by an external signal source connected to the IN1/2 pad. See Table 8 for input selection shunt positions.

Evaluating the MAX9762 and MAX9763

The MAX9760 EV kit is also capable of evaluating the SMBus/I²C-compatible MAX9762 and the parallel-drive MAX9763. To evaluate the MAX9762 or MAX9763 mono speaker/headphone driver, follow the directions given below.

When evaluating the MAX9763, ensure that the MAX9760 EV kit is not connected to the MAXSMBUS board, as undesirable device operation may occur.

Hardware Setup

The MAX9760 EV kit must be modified to evaluate the MAX9762 or MAX9763 mono speaker/headphone driver:

- 1) Replace the MAX9760 with MAX9762 or MAX9763.
- 2) Cut the trace between pins 2 and 3 of jumper JU7.
- 3) Install a 3-pin header into the location designated by JU7.
- 4) Install a shunt on pins 1–2 of jumper JU7.

The mono speaker output is accessed through the terminal block designated TB2.

Software Control and Gain Selection

The MAX9762 can be controlled with the provided MAX9760 EV kit software. Unlike the MAX9760, the MAX9762 and MAX9763 have an additional gain for the mono speaker. The feedback network that controls the mono gain is composed of components R18 and C16. If the output is forced into speaker mode (BTL), the mono gain is selected regardless of the A/B gain. If the output is forced into headphone mode (single ended), the output gain is either A or B. Refer to the MAX9760–MAX9763 data sheet for more details.

MAX9760/MAX9761 Evaluation System/Evaluation Kit

Evaluates: MAX9760—MAX9763

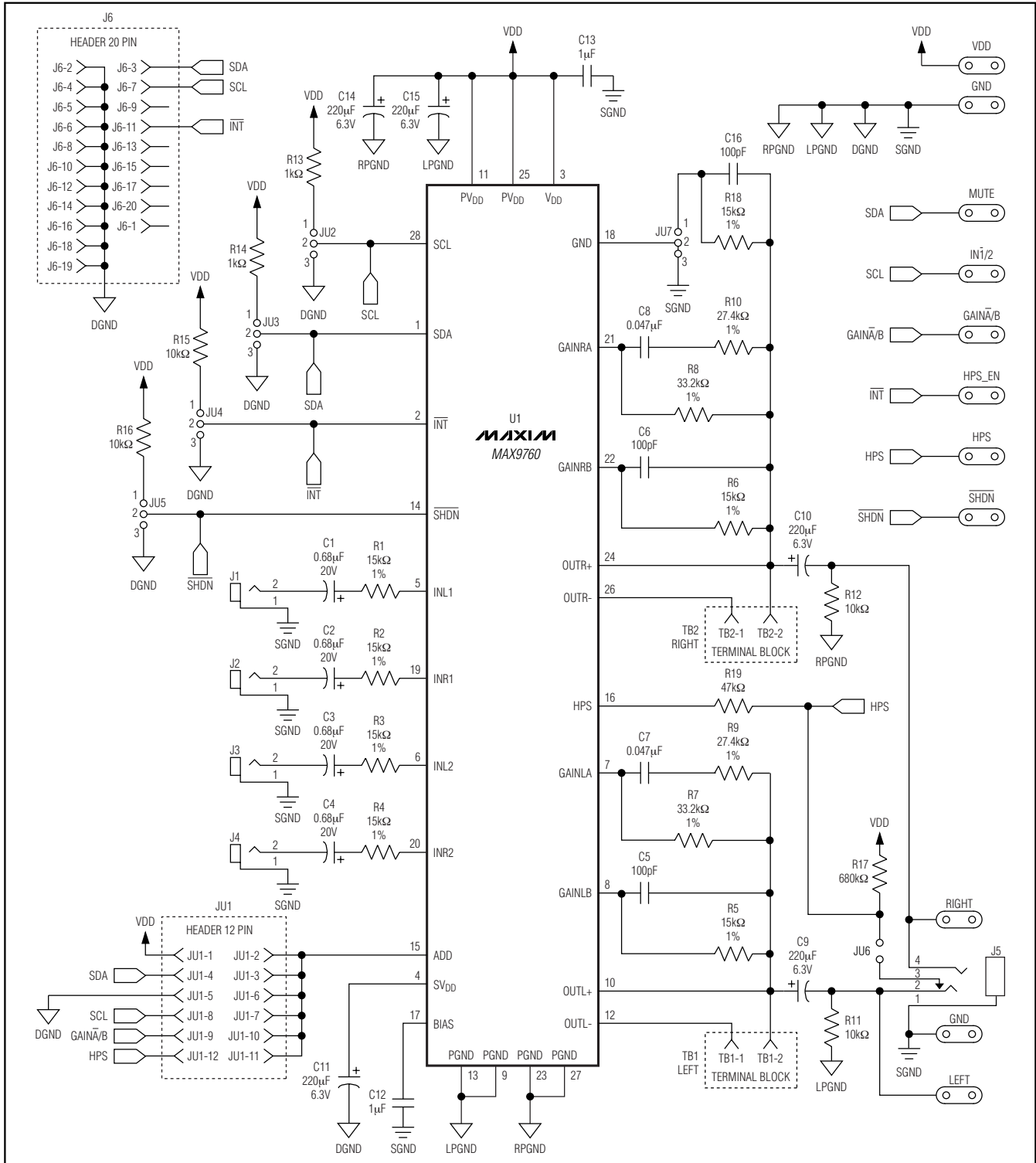

Figure 5. MAX9760 EV Kit Schematic

MAX9760/MAX9761 Evaluation System/Evaluation Kit

Evaluates: MAX9760—MAX9763

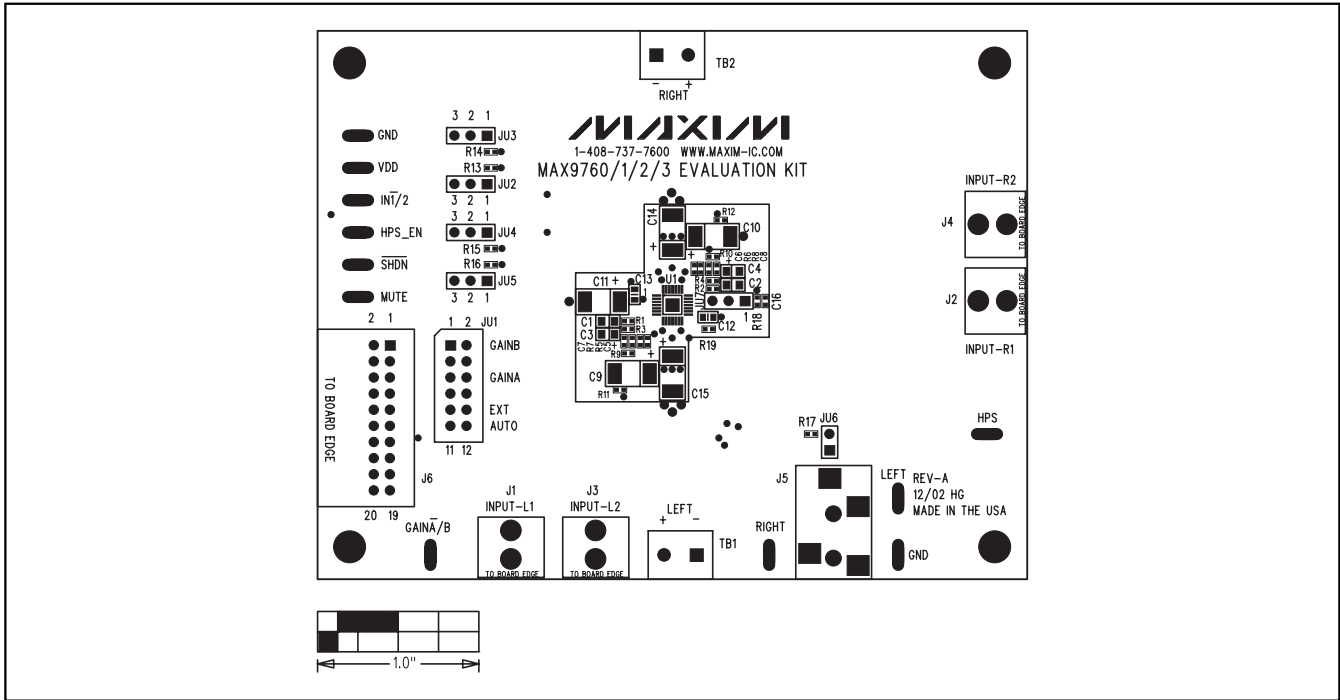

Figure 6. MAX9760 EV Kit Component Placement Guide—Component Side

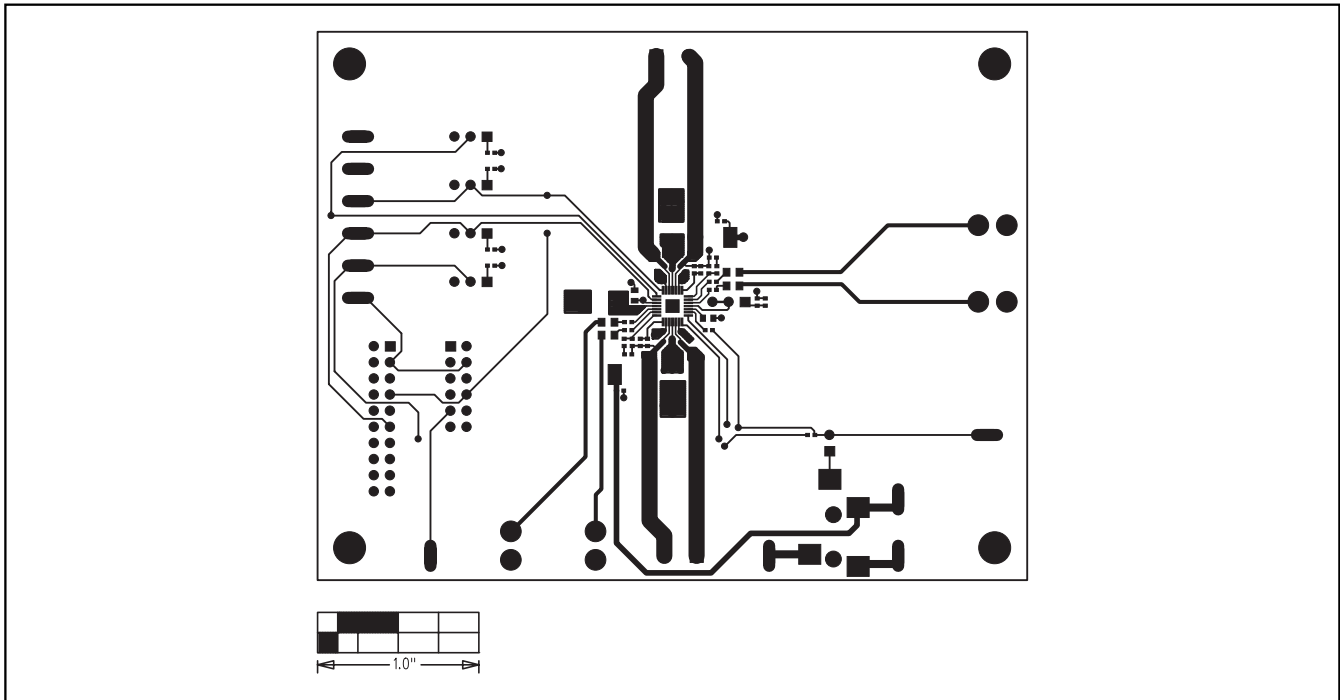

Figure 7. MAX9760 EV Kit PC Board Layout—Component Side

MAX9760/MAX9761 Evaluation System/Evaluation Kit

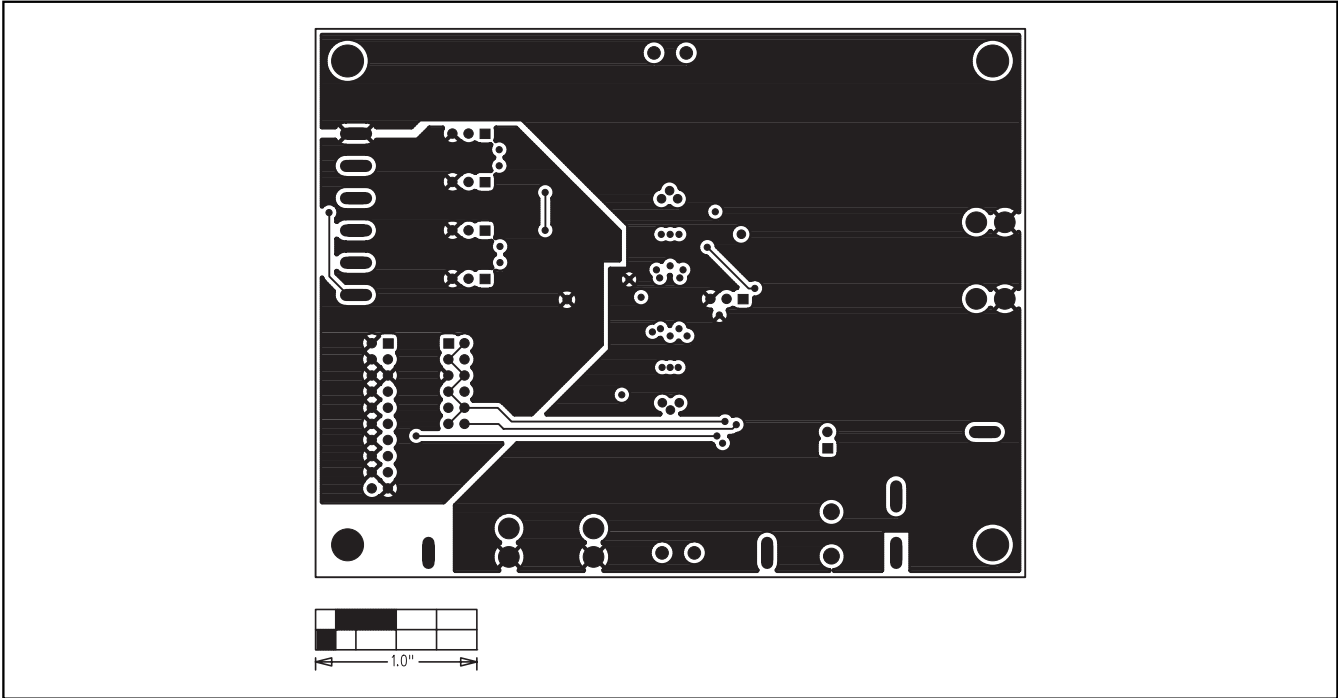

Figure 8. MAX9760 EV Kit PC Board Layout—Inner Layer 2

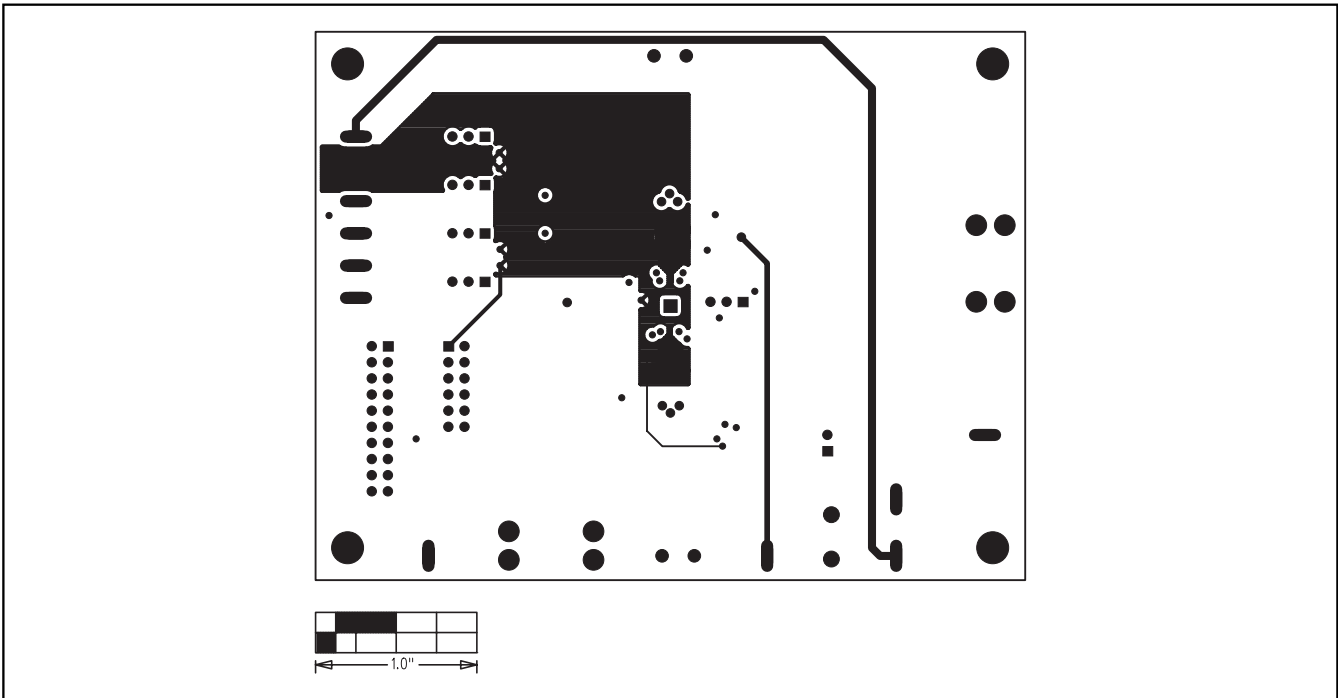

Figure 9. MAX9760 EV Kit PC Board Layout—Inner Layer 3

MAX9760/MAX9761 Evaluation System/Evaluation Kit

Evaluates: MAX9760—MAX9763

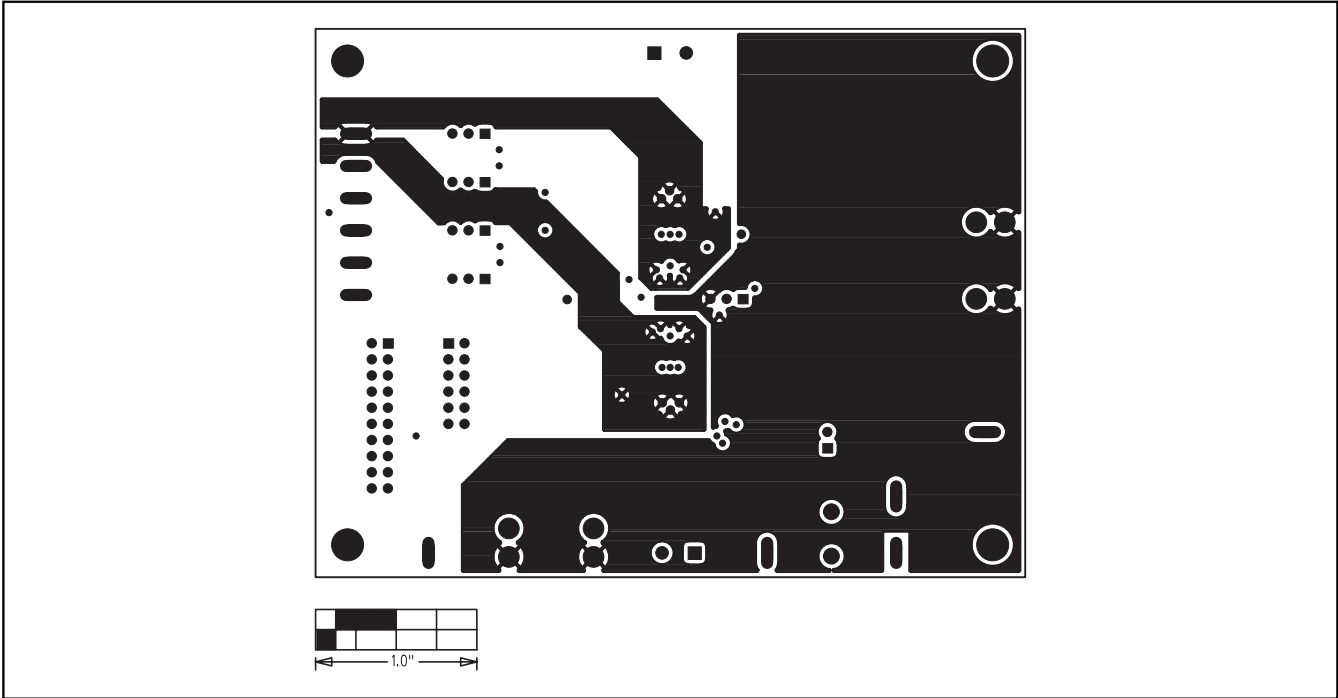

Figure 10. MAX9760 EV Kit PC Board Layout—Solder Side

MAX9760/MAX9761 Evaluation System/Evaluation Kit

Evaluates: MAX9760—MAX9763

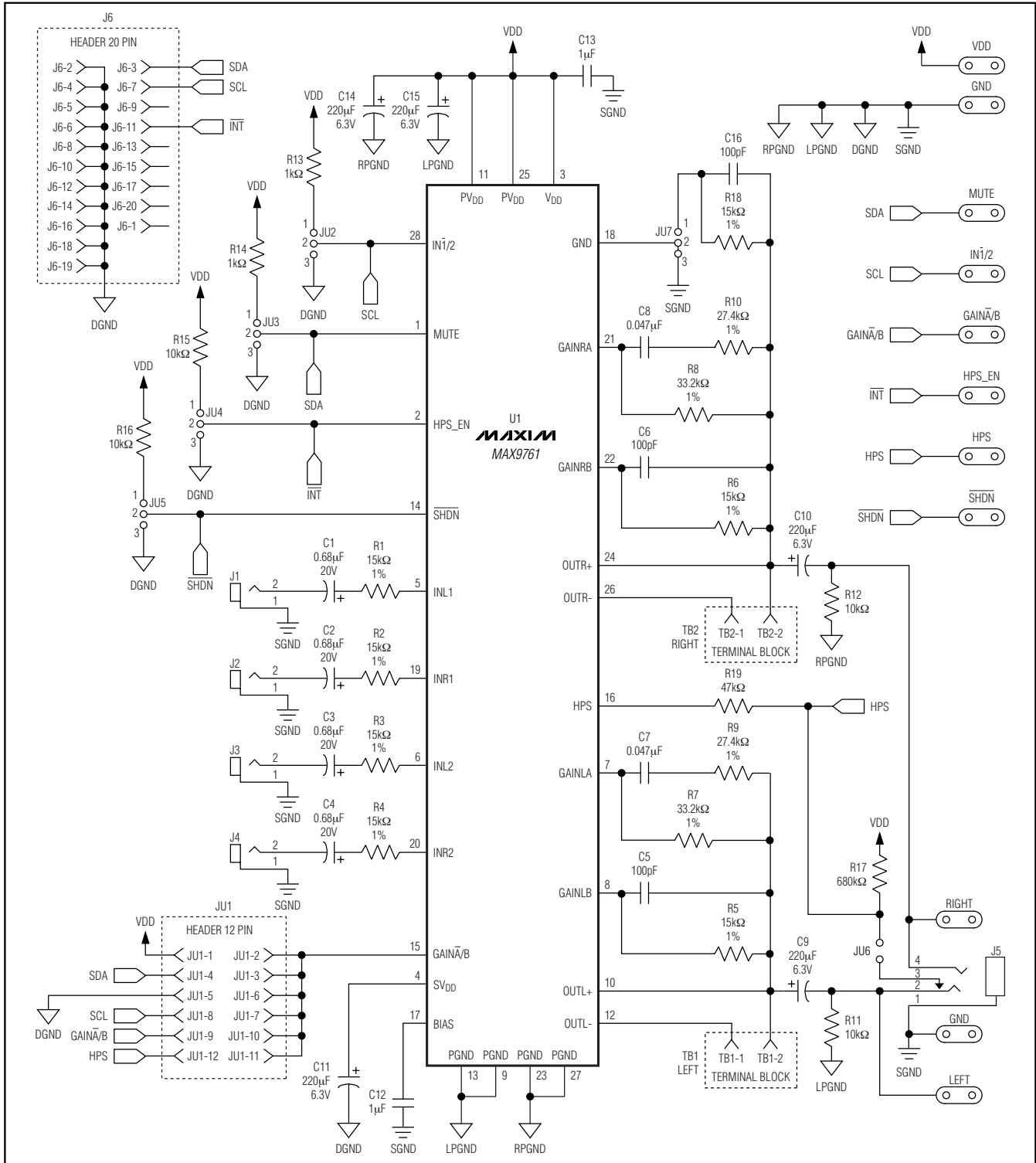

Figure 11. MAX9761 EV Kit Schematic

MAX9760/MAX9761 Evaluation System/Evaluation Kit

Evaluates: MAX9760—MAX9763

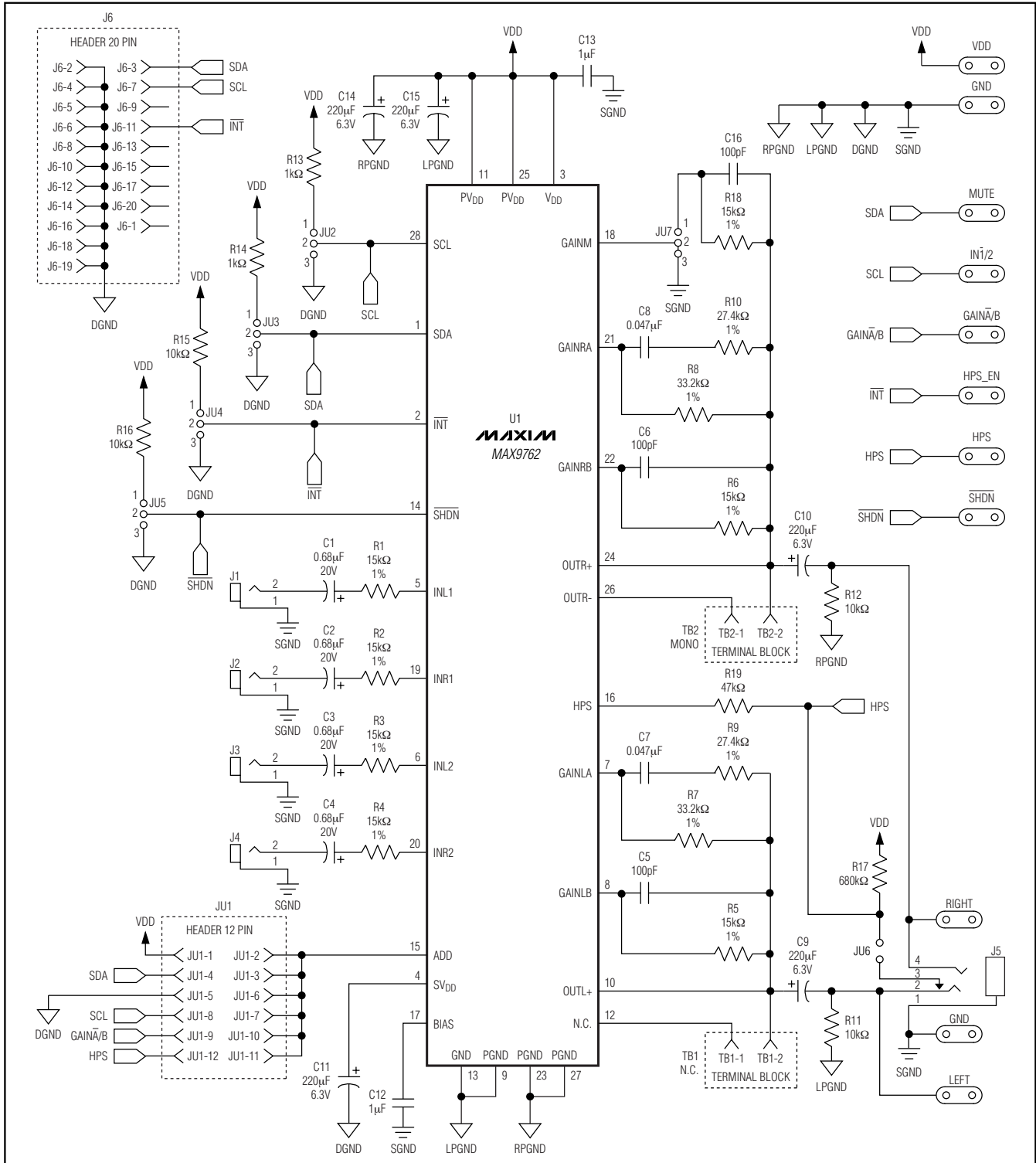

Figure 12. MAX9760 EV Kit Schematic (Modified for MAX9762)

MAX9760/MAX9761 Evaluation System/Evaluation Kit

Evaluates: MAX9760—MAX9763

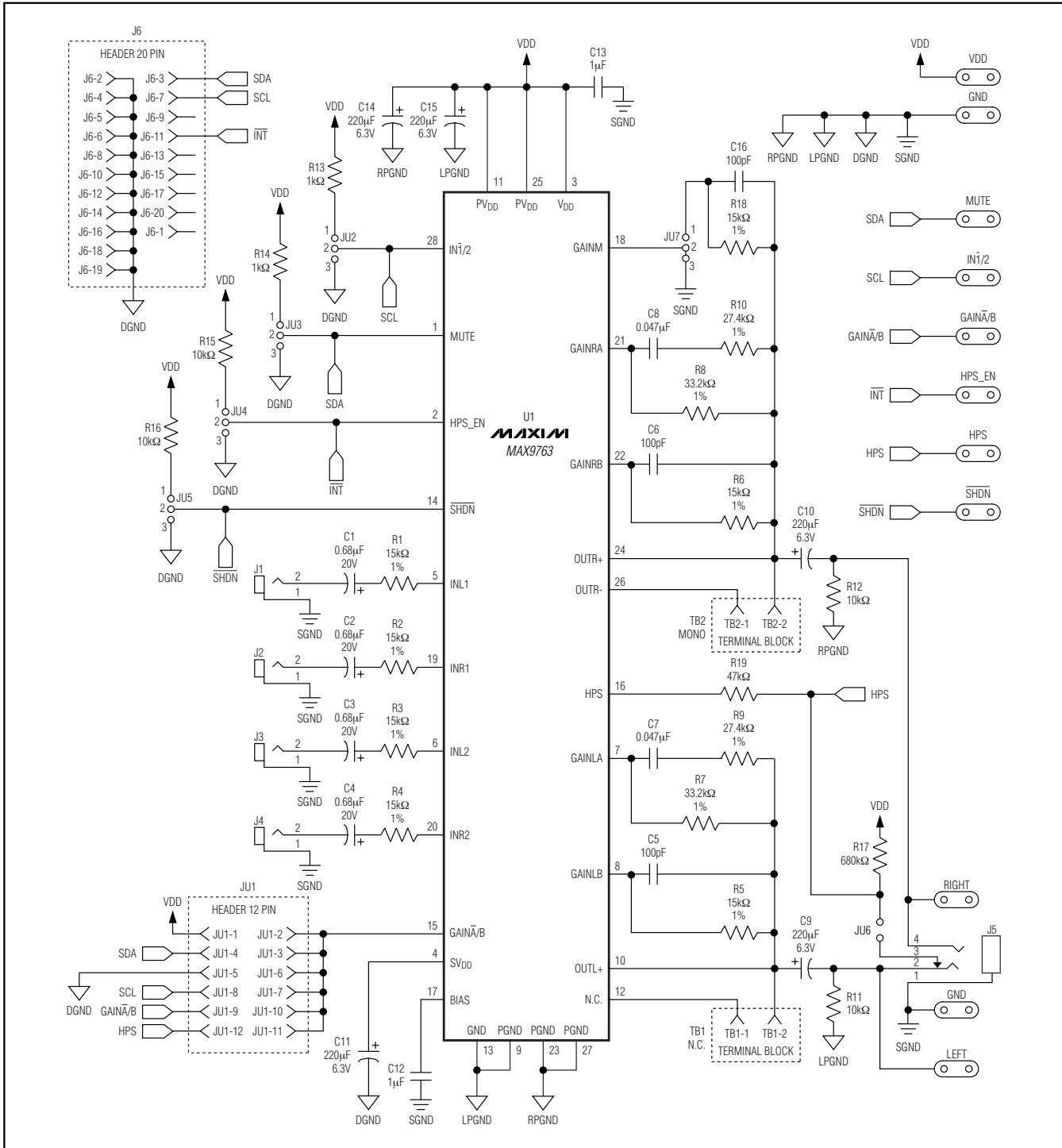

Figure 13. MAX9760 EV Kit Schematic (Modified for MAX9763)

Maxim cannot assume responsibility for use of any circuitry other than circuitry entirely embodied in a Maxim product. No circuit patent licenses are implied. Maxim reserves the right to change the circuitry and specifications without notice at any time.