

SCANSTA112

SCANSTA112 7-Port Multidrop IEEE 1149.1 (JTAG) Multiplexer



Literature Number: SNLS161H

SCANSTA112

7-Port Multidrop IEEE 1149.1 (JTAG) Multiplexer

General Description

The SCANSTA112 extends the IEEE Std. 1149.1 test bus into a multidrop test bus environment. The advantage of a multidrop approach over a single serial scan chain is improved test throughput and the ability to remove a board from the system and retain test access to the remaining modules. Each SCANSTA112 supports up to 7 local IEEE1149.1 scan chains which can be accessed individually or combined serially.

Addressing is accomplished by loading the instruction register with a value matching that of the Slot inputs. Backplane and inter-board testing can easily be accomplished by parking the local TAP Controllers in one of the stable TAP Controller states via a Park instruction. The 32-bit TCK counter enables built in self test operations to be performed on one port while other scan chains are simultaneously tested.

The STA112 has a unique feature in that the backplane port and the LSP0 port are bidirectional. They can be configured to alternatively act as the master or slave port so an alternate test master can take control of the entire scan chain network from the LSP0 port while the backplane port becomes a slave.

Features

- True IEEE 1149.1 hierarchical and multidrop addressable capability
- The 8 address inputs support up to 249 unique slot addresses, an Interrogation Address, Broadcast Address, and 4 Multi-cast Group Addresses (address 000000 is reserved)
- 7 IEEE 1149.1-compatible configurable local scan ports
- Bi-directional Backplane and LSP₀ ports are interchangeable slave ports
- Capable of ignoring $\overline{\text{TRST}}$ of the backplane port when it becomes the slave.
- Stitcher Mode bypasses level 1 and 2 protocols
- Mode Register₀ allows local TAPs to be bypassed, selected for insertion into the scan chain individually, or serially in groups of two or three
- Transparent Mode can be enabled with a single instruction to conveniently buffer the backplane IEEE 1149.1 pins to those on a single local scan port
- General purpose local port pass through bits are useful for delivering write pulses for Flash programming or monitoring device status.
- Known Power-up state
- $\overline{\text{TRST}}$ on all local scan ports
- 32-bit TCK counter
- 16-bit LFSR Signature Compactor
- Local TAPs can become TRI-STATE via the $\overline{\text{OE}}$ input to allow an alternate test master to take control of the local TAPs (LSP₀₋₃ have a TRI-STATE notification output)
- 3.0-3.6V V_{CC} Supply Operation
- Supports live insertion/withdrawal

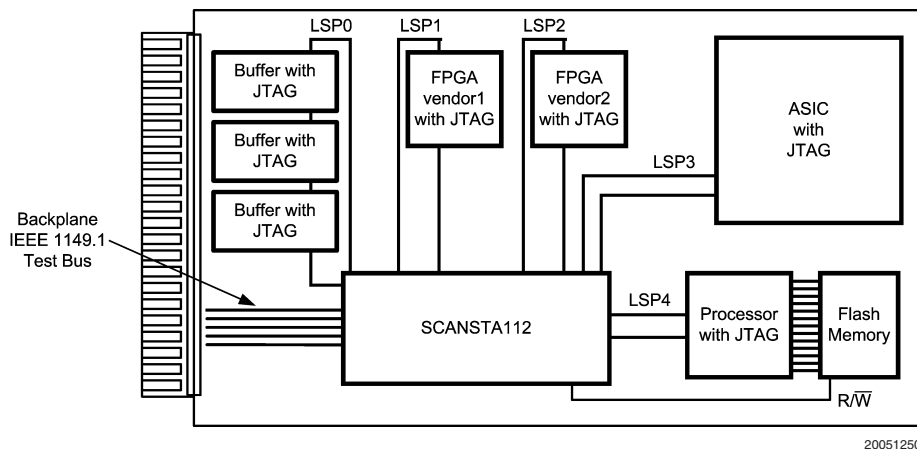

FIGURE 1. Typical use of SCANSTA112 for board-level management of multiple scan chains.

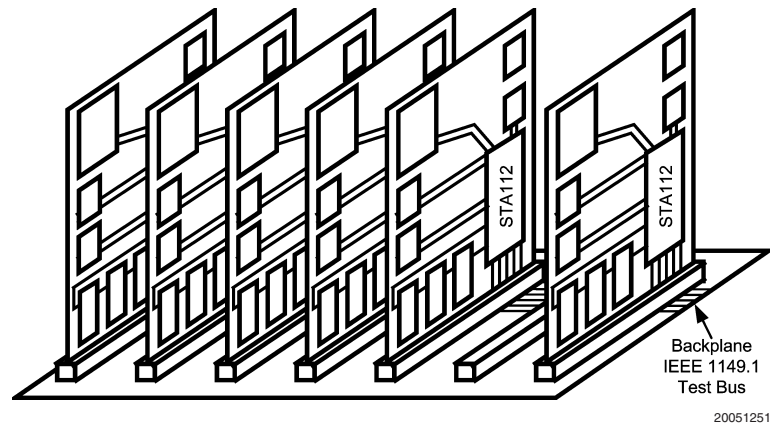

FIGURE 2. Example of SCANSTA112 in a multidrop addressable backplane.

Introduction

The SCANSTA112 is the third device in a series that enable multi-drop address and multiplexing of IEEE-1149.1 scan chains. The SCANSTA112 is a superset of its predecessors - the SCANPSC110 and the SCANSTA111. The STA112 has all features and functionality of these two previous devices.

The STA112 is essentially a support device for the IEEE 1149.1 standard. It is primarily used to partition scan chains into manageable sizes, or to isolate specific devices onto a separate chain (*Figure 1*). The benefits of multiple scan chains are improved fault isolation, faster test times, faster programming times, and smaller vector sets.

In addition to scan chain partitioning, the device is also addressable for use in a multidrop backplane environment (*Figure 2*). In this configuration, multiple IEEE-1149.1 accessible cards with an STA112 on board can utilize the same backplane test bus for system-level IEEE-1149.1 access. This approach facilitates a system-wide commitment to structural test and programming throughout the entire system life cycle.

Architecture

Figure 3 shows the basic architecture of the 'STA112. The device's major functional blocks are illustrated here.

The TAP Controller, a 16-state state machine, is the central control for the device. The instruction register and various test data registers can be scanned to exercise the various functions of the 'STA112 (these registers behave as defined in IEEE Std. 1149.1).

The 'STA112 selection controller provides the functionality that allows the 1149.1 protocol to be used in a multi-drop environment. It primarily compares the address input to the slot identification and enables the 'STA112 for subsequent scan operations.

The Local Scan Port Network (LSPN) contains multiplexing logic used to select different port configurations. The LSPN control block contains the Local Scan Port Controllers (LSPC) for each Local Scan Port ($LSP_0, LSP_1, \dots, LSP_n$). This control block receives input from the 'STA112 instruction register, mode registers, and the TAP controller. Each local port contains all four boundary scan signals needed to interface with the local TAPs plus the optional Test Reset signal (\overline{TRST}).

The TDI/TDO Crossover Master/Slave logic is used to define the bidirectional B0 and B1 ports in a Master/Slave configuration.

Block Diagram

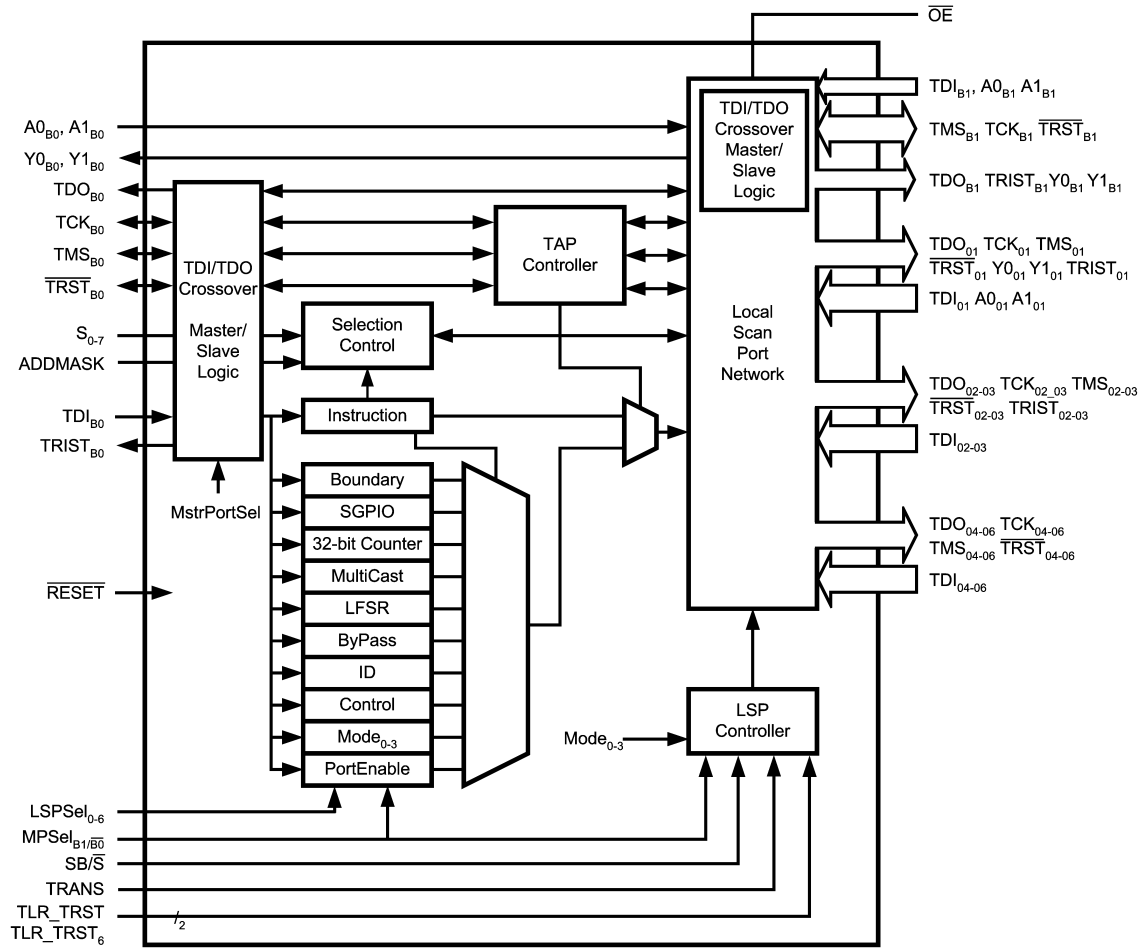

20051202

FIGURE 3. SCANSTA112 Block Diagram

Connection Diagrams

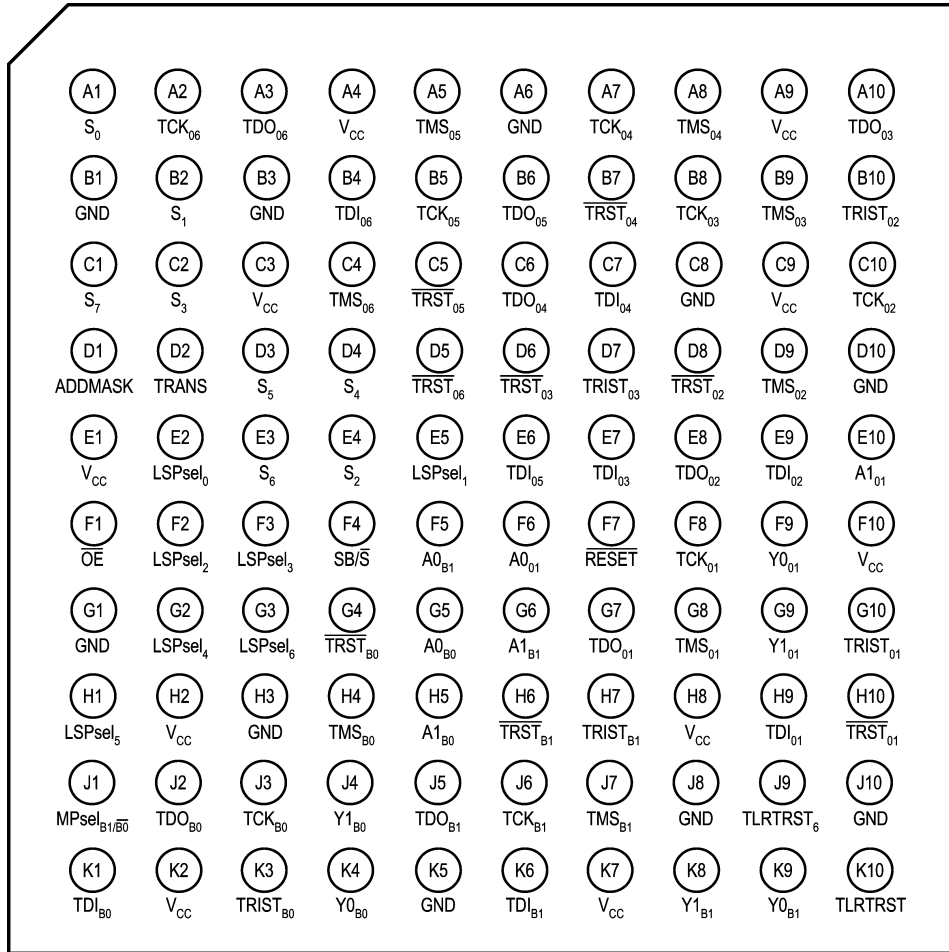

20051201

(BGA Top view)

Connection Diagrams (Continued)

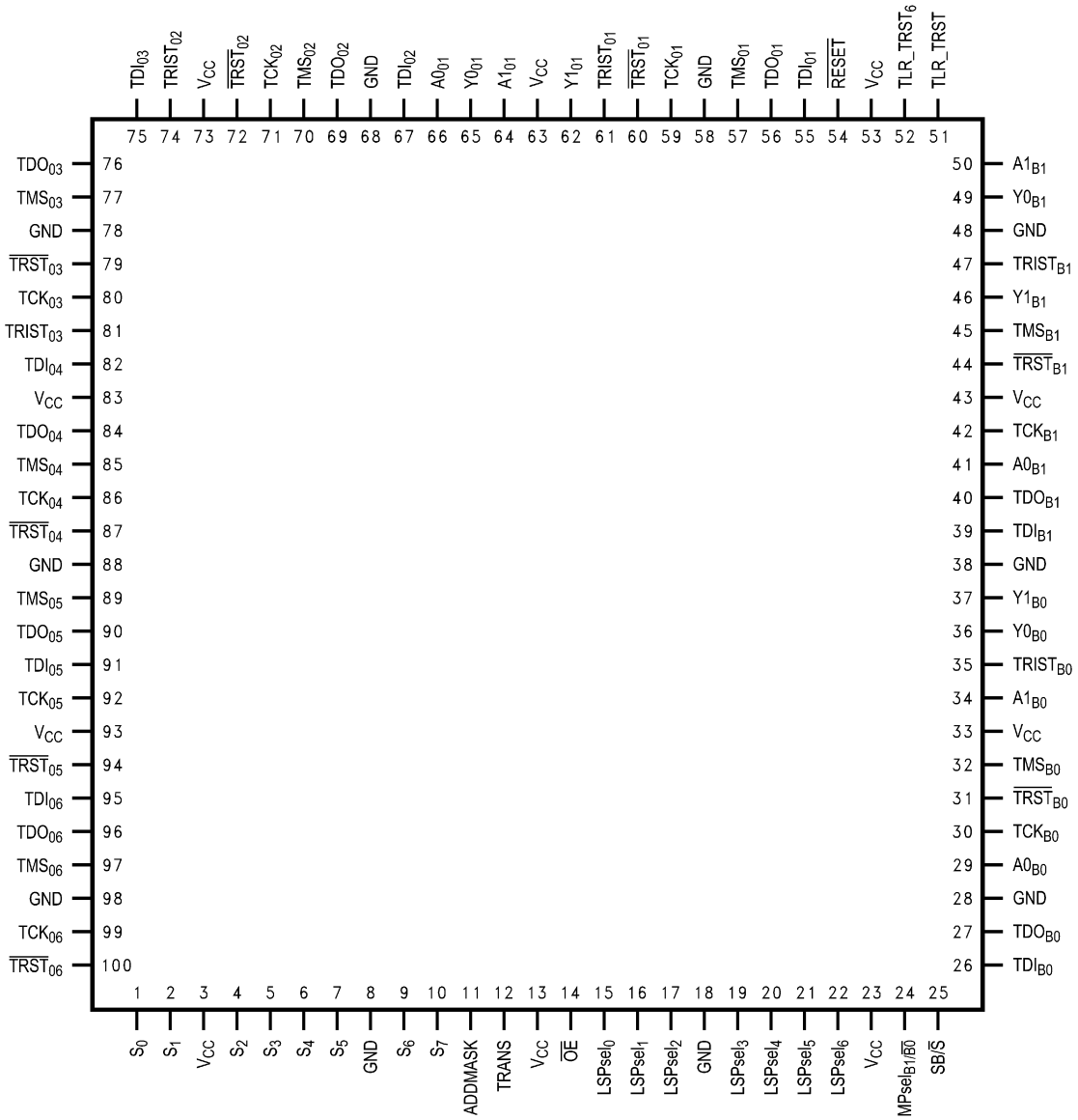

TQFP pinout

20051260

TABLE 1. Pin Descriptions

| Pin Name | No. Pins | I/O | Description |
|-----------------------------------------|----------|-----|----------------------------------------------------------------------------------------------------------------------------------------------------------------------------------------------------------------------------------------------------------------------------------------------------------------------------------------------------------------------------------------------------------------------------------------------------------------------------------------------------------------------------------------------------------------------------------------------------------------------------------------------------------------------------------------------------------------------------------|
| VCC | 10 | N/A | Power |
| GND | 10 | N/A | Ground |
| RESET | 1 | I | RESET Input: will force a reset of the device regardless of the current state. |
| ADDMASK | 1 | I | ADDRESS MASK input: Allows masking of lower slot input pins. |
| MPsel _{B1/B0} | 1 | I | MASTER PORT SELECTION: Controls selection of LSP _{B0} or LSP _{B1} as the backplane port. The unselected port becomes LSP ₀₀ . A value of "0" will select LSP _{B0} as the master port. |
| SB/S | 1 | I | Selects ScanBridge or Stitcher Mode. |
| LSPsel ₍₀₋₆₎ | 7 | I | In Stitcher Mode these inputs define which LSP's are to be included in the scan chain |
| TRANS | 1 | I | Transparent Mode enable input: The value of this pin is loaded into the TRANSENABLE bit of the control register at power-up. This value is used to control the presence of registers and pad-bits in the scan chain while in the stitcher mode. |
| TLR_TRST | 1 | I | Sets the driven value of TRST ₀₋₅ when LSP TAPs are in TLR and the device is not being reset. During RESET = "0" or TRST _B = "0" (IgnoreReset = "0") TRST _n = "0". This pin is to be tied low to match the function of the SCANSTA111 |
| TLR_TRST ₆ | 1 | I | This pin affects TRST of LSP ₆ only. This pin is to be tied low to match the function of the SCANSTA111 |
| TDI _{B0} , TDI _{B1} | 2 | I | BACKPLANE TEST DATA INPUT: All backplane scan data is supplied to the 'STA112 through this input pin. MPsel _{B1/B0} determines which port is the master backplane port and which is LSP ₀₀ . This input has a 25KΩ internal pull-up resistor and no ESD clamp diode (ESD is controlled with an alternate method). When the device is power-off (V _{DD} floating), this input appears to be a capacitive load to ground (Note 1). When V _{DD} = 0V (i.e.; not floating but tied to V _{SS}) this input appears to be a capacitive load with the pull-up to ground. |
| TMS _{B0} , TMS _{B1} | 2 | I/O | BACKPLANE TEST MODE SELECT: Controls sequencing through the TAP Controller of the 'STA112. Also controls sequencing of the TAPs which are on the local scan chains. MPsel _{B1/B0} determines which port is the master backplane port and which is LSP ₀₀ . This bidirectional TRI-STATE pin has 24mA of drive current, with a 25KΩ internal pull-up resistor and no ESD clamp diode (ESD is controlled with an alternate method). When the device is power-off (V _{DD} floating), this input appears to be a capacitive load to ground (Note 1). When V _{DD} = 0V (i.e.; not floating but tied to V _{SS}) this input appears to be a capacitive load with the pull-up to ground. |
| TDO _{B0} , TDO _{B1} | 2 | I/O | BACKPLANE TEST DATA OUTPUT: This output drives test data from the 'STA112 and the local TAPs, back toward the scan master controller. This bidirectional TRI-STATE pin has 12mA of drive current. MPsel _{B1/B0} determines which port is the master backplane port and which is LSP ₀₀ . Output is sampled during interrogation addressing. When the device is power-off (V _{DD} = 0V or floating), this output appears to be a capacitive load (Note 1). |
| TCK _{B0} , TCK _{B1} | 2 | I/O | TEST CLOCK INPUT FROM THE BACKPLANE: This is the master clock signal that controls all scan operations of the 'STA112 and of the local scan ports. MPsel _{B1/B0} determines which port is the master backplane port and which is LSP ₀₀ . These bidirectional TRI-STATE pins have 24mA of drive current with hysteresis. This input has no pull-up resistor and no ESD clamp diode (ESD is controlled with an alternate method). When the device is power-off (V _{DD} floating), this input appears to be a capacitive load to ground (Note 1). When V _{DD} = 0V (i.e.; not floating but tied to V _{SS}) this input appears to be a capacitive load to ground. |
| TRST _{B0} , TRST _{B1} | 2 | I/O | TEST RESET: An asynchronous reset signal (active low) which initializes the 'STA112 logic. MPsel _{B1/B0} determines which port is the master backplane port and which is LSP ₀₀ . This bidirectional TRI-STATE pin has 24mA of drive current, with a 25KΩ internal pull-up resistor and no ESD clamp diode (ESD is controlled with an alternate method). When the device is power-off (V _{DD} floating), this pin appears to be a capacitive load to ground (Note 1). When V _{DD} = 0V (i.e.; not floating but tied to V _{SS}) this input appears to be a capacitive load with the pull-up to ground. |

TABLE 1. Pin Descriptions (Continued)

| Pin Name | No. Pins | I/O | Description |
|------------------------------------------------------------------------------|----------|-----|----------------------------------------------------------------------------------------------------------------------------------------------------------------------------------------------------------------------------------------------------------------------------------------------------------------------------------------|
| TRIST _{B0} , TRIST _{B1} , TRIST ₍₀₁₋₀₃₎ | 5 | O | TRI-STATE NOTIFICATION OUTPUT: This signal is asserted high when the associated TDO is TRI-STATEd. Associated means TRIST _{B0} is for TDO _{B0} , TRIST ₀₁ is for TDO ₀₁ , etc. This output has 12mA of drive current. |
| A0 _{B0} , A1 _{B0} , A0 _{B1} , A1 _{B1} | 4 | I | BACKPLANE PASS-THROUGH INPUT: A general purpose input which is driven to the Y _n of a single selected LSP. (Not available when multiple LSPs are selected). This input has a 25KΩ internal pull-up resistor. MPsel _{B1/B0} determines which port is the master backplane port and which is LSP ₀₀ . |
| Y0 _{B0} , Y1 _{B0} , Y0 _{B1} , Y1 _{B1} | 4 | O | BACKPLANE PASS-THROUGH OUTPUT: A general purpose output which is driven from the A _n of a single selected LSP. (Not available when multiple LSPs are selected). This TRI-STATE output has 12mA of drive current. MPsel _{B1/B0} determines which port is the master backplane port and which is LSP ₀₀ . |
| S ₍₀₋₇₎ | 8 | I | SLOT IDENTIFICATION: The configuration of these pins is used to identify (assign a unique address to) each 'STA112 on the system backplane |
| OE | 1 | I | OUTPUT ENABLE for the Local Scan Ports, active low. When high, this active-low control signal TRI-STATEs all local scan ports on the 'STA112, to enable an alternate resource to access one or more of the local scan chains. |
| TDO ₍₀₁₋₀₆₎ | 6 | O | TEST DATA OUTPUTS: Individual output for each of the local scan ports . These TRI-STATE outputs have 12mA of drive current. |
| TDI ₍₀₁₋₀₆₎ | 6 | I | TEST DATA INPUTS: Individual scan data input for each of the local scan ports. This input has a 25KΩ internal pull-up resistor. |
| TMS ₍₀₁₋₀₆₎ | 6 | O | TEST MODE SELECT OUTPUTS: Individual output for each of the local scan ports. TMS _n does not provide a pull-up resistor (which is assumed to be present on a connected TMS input, per the IEEE 1149.1 requirement) . These TRI-STATE outputs have 24mA of drive current. |
| TCK ₍₀₁₋₀₆₎ | 6 | O | LOCAL TEST CLOCK OUTPUTS: Individual output for each of the local scan ports. These are buffered versions of TCK _B . These TRI-STATE outputs have 24mA of drive current. |
| TRST ₍₀₁₋₀₆₎ | 6 | O | LOCAL TEST RESETS: A gated version of TRST _B . These TRI-STATE outputs have 24mA of drive current. |
| A0 ₀₁ , A1 ₀₁ | 2 | I | LOCAL PASS-THROUGH INPUTS: General purpose inputs which can be driven to the backplane pin Y _B . (Only on LSP ₀ and LSP ₁ . Only available when a single LSP is selected) . These inputs have a 25KΩ internal pull-up resistor. |
| Y0 ₀₁ , Y1 ₀₁ | 2 | O | LOCAL PASS-THROUGH OUTPUT: General purpose outputs which can be driven from the backplane pin A _B . (Only on LSP ₀ and LSP ₁ . Only available when a single LSP is selected) . These TRI-STATE outputs have 12mA of drive current. |

Note 1: Refer to the IBIS model on our website for I/O characteristics.

Application Overview

ADDRESSING SCHEME

The SCANSTA112 architecture extends the functionality of the IEEE 1149.1 Standard by supplementing that protocol with an addressing scheme which allows a test controller to communicate with specific 'STA112s within a network of 'STA112s. That network can include both multi-drop and hierarchical connectivity. In effect, the 'STA112 architecture allows a test controller to dynamically select specific portions of such a network for participation in scan operations. This allows a complex system to be partitioned into smaller blocks for testing purposes. The 'STA112 provides two levels of test-network partitioning capability. First, a test controller can select individual 'STA112s, specific sets of 'STA112s (multi-cast groups), or all 'STA112s (broadcast). This 'STA112-selection process is supported by a Level-1 com-

munication protocol. Second, within each selected 'STA112, a test controller can select one or more of the chip's seven local scan-ports. That is, individual local ports can be selected for inclusion in the (single) scan-chain which a 'STA112 presents to the test controller. This mechanism allows a controller to select specific scan-chains within the overall scan network. The port-selection process is supported by a Level-2 protocol.

HIERARCHICAL SUPPORT

Multiple SCANSTA112's can be used to assemble a hierarchical boundary-scan tree. In such a configuration, the system tester can configure the local ports of a set of 'STA112s so as to connect a specific set of local scan-chains to the active scan chain. Using this capability, the tester can selectively communicate with specific portions of a target system. The tester's scan port is connected to the backplane scan port of a root layer of 'STA112s, each of which can be

Application Overview (Continued)

selected using multi-drop addressing. A second tier of 'STA112s can be connected to this root layer, by connecting a local port (LSP) of a root-layer 'STA112 to the backplane port of a second-tier 'STA112. This process can be continued to construct a multi-level scan hierarchy. 'STA112 local ports which are not cascaded into higher-level 'STA112s can be thought of as the terminal leaves of a scan tree. The test master can select one or more target leaves by selecting and configuring the local ports of an appropriate set of 'STA112s in the test tree.

STANDARD SCANBRIDGE MODE

ScanBridge mode refers to functionality and protocol that has been used by National since the introduction of the PSC110 in 1993. This functionality consists of a multidrop addressable IEEE1149.1 switch. This enables one (or more) device to be selected from many that are connected to a parallel IEEE1149.1 bus or backplane. The second function that ScanBridge mode accomplishes is to act as a mux for multiple IEEE1149.1 local scan chains. The Local Scan Ports (LSP) of the device creates a connection between one or more of the local scan chains to the backplane bus.

To accomplish this functionality the ScanBridge has two levels of protocol and an operational mode. Level 1 protocol refers to the required actions to address/select the desired ScanBridge. Level 2 protocol is required to configuring the

mux'ing function and enable the connection (UNPARK) between the local scan chain and the backplane bus via an LSP. Upon completion of level 1 and 2 protocols the ScanBridge is prepared for its operational mode. This is where scan vectors are moved from the backplane bus to the desired local scan chain(s).

STITCHER MODE

Stitcher Mode is a method of skipping level 1 and 2 protocol of the ScanBridge mode of operation. This is accomplished via external pins. When in stitcher mode the SCANSTA112 will go directly to the operational mode.

TRANSPARENT MODE

Transparent mode refers to a condition of operation in which there are no pad-bits or SCANSTA112 registers in the scan chain. The Transparent mode of operation is available in both ScanBridge and Stitcher modes. Only the activation method differs. Once transparent mode has been activated there is no difference in operation. Transparent mode allows for the use of vectors that have been generated for a chain where these bits were not included.

Check with your ATPG tool vendor to ensure support of these features.

For details regarding the internal operation of the SCANSTA112 device, refer to applications note AN-1259 SCANSTA112 Designers Reference.

Absolute Maximum Ratings (Note 2)

| | |
|-------------------------------------------------|-----------------|
| Supply Voltage (V_{CC}) | -0.3V to +4.0V |
| DC Input Diode Current (I_{IK}) | |
| $V_I = -0.5V$ | -20 mA |
| DC Input Voltage (V_I) | -0.5V to +3.9V |
| DC Output Diode Current (I_{OK}) | |
| $V_O = -0.5V$ | -20 mA |
| DC Output Voltage (V_O) | -0.3V to +3.9V |
| DC Output Source/Sink Current (I_O) | ±50 mA |
| DC V_{CC} or Ground Current per Output Pin | ±50 mA |
| DC Latchup Source or Sink Current | ±300 mA |
| Junction Temperature (Plastic) | +150°C |
| Storage Temperature | -65°C to +150°C |
| Lead Temperature (Solder, 4sec) | |
| 100L FBGA | 220°C |
| 100L TQFP | 220°C |
| Max Package Power Capacity @ 25°C | |
| 100L FBGA | 3.57W |
| 100L TQFP | 2.11W |
| Thermal Resistance (θ_{JA}) | |

| | |
|---------------------------------------|------------|
| 100L FBGA | 35°C/W |
| 100L TQFP | 59.1°C/W |
| Package Derating above +25°C | |
| 100L FBGA | 28.57mW/°C |
| 100L TQFP | 16.92mW/°C |
| ESD Last Passing Voltage (HBM Min) | 2500V |

Recommended Operating Conditions

| | |
|---------------------------------|----------------|
| Supply Voltage (V_{CC}) | |
| 'STA112 | 3.0V to 3.6V |
| Input Voltage (V_I) | 0V to V_{CC} |
| Output Voltage (V_O) | 0V to V_{CC} |
| Operating Temperature (T_A) | |
| Industrial | -40°C to +85°C |

Note 2: Absolute maximum ratings are those values beyond which damage to the device may occur. The databook specifications should be met, without exception, to ensure that the system design is reliable over its power supply, temperature, and output/input loading variables. National does not recommend operation of SCAN STA products outside of recommended operation conditions.

DC Electrical Characteristics

Over recommended operating supply voltage and temperature ranges unless otherwise specified

| Symbol | Parameter | Conditions | Min | Max | Units |
|----------|-------------------------------------------------------------------------------------------------------------------------------------------------------------------------------------------------------------------------------------------------------------------------------------------|---------------------------------------------------------|-----------------|------|-------|
| V_{IH} | Minimum High Input Voltage | $V_{OUT} = 0.1V$ or $V_{CC} - 0.1V$ | 2.1 | | V |
| V_{IL} | Maximum Low Input Voltage | $V_{OUT} = 0.1V$ or $V_{CC} - 0.1V$ | | 0.8 | V |
| V_{OH} | Minimum High Output Voltage All Outputs and I/O Pins | $I_{OUT} = -100 \mu A$ $V_{IN} = V_{IH}$ or V_{IL} | $V_{CC} - 0.2v$ | | V |
| V_{OH} | Minimum High Output Voltage TDO _{B0} , TDO _{B1} , TRIST _{B0} , TRIST _{B1} , Y0 _{B0} , Y1 _{B0} , Y0 _{B1} , Y1 _{B1} , TDO ₍₀₁₋₀₆₎ , Y0 ₀₁ , Y1 ₀₁ , TRIST ₍₀₁₋₀₃₎ | $I_{OUT} = -12 mA$ All Outputs Loaded | 2.4 | | V |
| V_{OH} | Minimum High Output Voltage TMS _{B0} , TMS _{B1} , TCK _{B0} , TCK _{B1} , \overline{TRST}_{B0} , \overline{TRST}_{B1} , TMS ₍₀₁₋₀₆₎ , TCK ₍₀₁₋₀₆₎ , $\overline{TRST}_{(01-06)}$ | $I_{OUT} = -24mA$ | 2.2 | | V |
| V_{OL} | Maximum Low Output Voltage All Outputs and I/O Pins | $I_{OUT} = +100 \mu A$ $V_{IN} = V_{IH}$ or V_{IL} | | 0.2 | V |
| V_{OL} | Maximum Low Output Voltage TDO _{B0} , TDO _{B1} , TRIST _{B0} , TRIST _{B1} , Y0 _{B0} , Y1 _{B0} , Y0 _{B1} , Y1 _{B1} , TDO ₍₀₁₋₀₆₎ , Y0 ₀₁ , Y1 ₀₁ , TRIST ₍₀₁₋₀₃₎ | $I_{OUT} = +12 mA$ | | 0.4 | V |
| V_{OL} | Maximum Low Output Voltage TMS _{B0} , TMS _{B1} , TCK _{B0} , TCK _{B1} , \overline{TRST}_{B0} , \overline{TRST}_{B1} , TMS ₍₀₁₋₀₆₎ , TCK ₍₀₁₋₀₆₎ , $\overline{TRST}_{(01-06)}$ | $I_{OUT} = +24mA$ | | 0.55 | V |
| VIKL | Maximum Input Clamp Diode Voltage | $I_{IK} = -18mA$ | | -1.2 | V |
| I_{IN} | Maximum Input Leakage Current (non-resistor input pins) | $V_{IN} = V_{CC}$ or GND | | ±5.0 | μA |

DC Electrical Characteristics (Continued)

Over recommended operating supply voltage and temperature ranges unless otherwise specified

| Symbol | Parameter | Conditions | Min | Max | Units |
|-----------|-------------------------------------------------------------------------------------------------------------------------------------------------------------------------------------------------------------------------------------------------------------------|-------------------------------------------------|-----|-----------|---------|
| I_{ILR} | Input Current Low (Input and I/O pins with pull-up resistors: TDI_{B0} , TDI_{B1} , TMS_{B0} , TMS_{B1} , \overline{TRST}_{B0} , \overline{TRST}_{B1} , $A0_{B0}$, $A1_{B0}$, $A0_{B1}$, $A1_{B1}$, $TDI_{(01-06)}$, $A0_{01}$, $A1_{01}$) | $V_{IN} = GND$ | -45 | -200 | μA |
| I_{IH} | Input High Current (Input and I/O pins with pull-up resistors: TDI_{B0} , TDI_{B1} , TMS_{B0} , TMS_{B1} , \overline{TRST}_{B0} , \overline{TRST}_{B1} , $A0_{B0}$, $A1_{B0}$, $A0_{B1}$, $A1_{B1}$, $TDI_{(01-06)}$, $A0_{01}$, $A1_{01}$) | $V_{IN} = V_{CC}$ | | 5.0 | μA |
| I_{OFF} | Power-off Leakage Current Outputs and I/O pins without pull-up resistors | $V_{CC} = 0V$, $V_{IN} = 3.6V$ (Note 3) | | ± 5.0 | μA |
| | Outputs and I/O pins with pull-up resistors | | | ± 200 | μA |
| I_{OZ} | Maximum TRI-STATE Leakage Current Outputs and I/O pins without pull-up resistors | | | ± 5.0 | μA |
| I_{CC} | Maximum Quiescent Supply Current | $V_{IN} = V_{CC}$ or GND | | 3.8 | mA |
| I_{CCD} | Maximum Dynamic Supply Current | $V_{IN} = V_{CC}$ or GND, Input Freq = 25MHz | | 68 | mA |

Note 3: Guaranteed by equivalent test method.**AC Electrical Characteristics: Scan Bridge Mode**

Over recommended operating supply voltage and temperature ranges unless otherwise specified (Note 5).

| Symbol | Parameter | Conditions | Typ | Max | Units |
|--------------------------|-------------------------------------------------------------|------------|------|------|-------|
| t_{PHL} , t_{PLH} | Propagation Delay TCK_{B0} to TDO_{B0} or TDO_{B1} | | 8.5 | 13.5 | ns |
| t_{PHL} , t_{PLH} | Propagation Delay TCK_{B1} to TDO_{B0} or TDO_{B1} | | 8.5 | 14.0 | ns |
| t_{PHL} , t_{PLH} | Propagation Delay TCK_{B0} to $TDO_{(01-06)}$ | | 7.5 | 12.5 | ns |
| t_{PHL} , t_{PLH} | Propagation Delay TCK_{B1} to $TDO_{(01-06)}$ | | 7.5 | 13.0 | ns |
| t_{PHL} , t_{PLH} | Propagation Delay TMS_{B0} to TMS_{B1} | | 8.0 | 12.0 | ns |
| t_{PHL} , t_{PLH} | Propagation Delay TMS_{B1} to TMS_{B0} | | 8.0 | 12.0 | ns |
| t_{PHL} , t_{PLH} | Propagation Delay TMS_{B0} to $TMS_{(01-06)}$ | | 8.0 | 12.0 | ns |
| t_{PHL} , t_{PLH} | Propagation Delay TMS_{B1} to $TMS_{(01-06)}$ | | 8.0 | 12.0 | ns |
| t_{PHL} , t_{PLH} | Propagation Delay TCK_{B0} to TCK_{B1} | | 8.0 | 12.0 | ns |
| t_{PHL} , t_{PLH} | Propagation Delay TCK_{B1} to TCK_{B0} | | 8.0 | 12.0 | ns |
| t_{PHL} , t_{PLH} | Propagation Delay TCK_{B0} to $TCK_{(01-06)}$ | | 7.5 | 12.0 | ns |
| t_{PHL} , t_{PLH} | Propagation Delay TCK_{B1} to $TCK_{(01-06)}$ | | 7.5 | 12.0 | ns |
| t_{PHL} , t_{PLH} | Propagation Delay TCK_{B0} to \overline{TRST}_{B1} | | 11.5 | 18.0 | ns |
| t_{PHL} , t_{PLH} | Propagation Delay TCK_{B1} to \overline{TRST}_{B0} | | 11.5 | 18.0 | ns |

AC Electrical Characteristics: Scan Bridge Mode (Continued)

Over recommended operating supply voltage and temperature ranges unless otherwise specified (Note 5).

| Symbol | Parameter | Conditions | Typ | Max | Units |
|--------------------------|---------------------------------------------------------------------------------------|------------|------|------|-------|
| t_{PHL} , t_{PLH} | Propagation Delay TCK _{B0} to $\overline{TRST}_{(01-06)}$ | | 12.0 | 18.5 | ns |
| t_{PHL} , t_{PLH} | Propagation Delay TCK _{B1} to $\overline{TRST}_{(01-06)}$ | | 12.0 | 18.5 | ns |
| t_{PHL} | Propagation Delay TCK _{Bn} to TRIST _{Bn} | | 8.5 | 12.5 | ns |
| t_{PHL} | Propagation Delay TCK _{Bn} to TRIST ₍₀₁₋₀₃₎ | | 8.0 | 12.0 | ns |
| t_{PZL} , t_{PZH} | Propagation Delay TCK _{Bn} to TDO _{Bn} or TDO ₍₀₁₋₀₆₎ | | 9.0 | 14.5 | ns |
| t_{PHL} , t_{PLH} | Propagation Delay An to Yn | | 6.0 | 9.0 | ns |

AC Timing Characteristics: Scan Bridge Mode

Over recommended operating supply voltage and temperature ranges unless otherwise specified (Notes 4, 5).

| Symbol | Parameter | Conditions | Min | Max | Units |
|-----------|----------------------------------------------------------------|-------------------|------|-----|-------|
| t_S | Setup Time TMS _{Bn} to TCK _{Bn} | | 2.5 | | ns |
| t_H | Hold Time TMS _{Bn} to TCK _{Bn} | | 1.5 | | ns |
| t_S | Setup Time TDI _{Bn} to TCK _{Bn} | | 3.0 | | ns |
| t_H | Hold Time TDI _{Bn} to TCK _{Bn} | | 2.0 | | ns |
| t_S | Setup Time TDI ₍₀₁₋₀₆₎ to TCK _{Bn} | | 1.0 | | ns |
| t_H | Hold Time TDI ₍₀₁₋₀₆₎ to TCK _{Bn} | | 3.5 | | ns |
| t_{REC} | Recovery Time TCK _{Bn} from \overline{TRST}_{Bn} | | 1.0 | | ns |
| t_W | Clock Pulse Width TCK _{Bn} (H or L) | $t_R/t_F = 1.0ns$ | 10.0 | | ns |
| t_{WL} | Reset Pulse Width $\overline{TRST}_{Bn}(L)$ | $t_R/t_F = 1.0ns$ | 2.5 | | ns |
| F_{MAX} | Maximum Clock Frequency (Note 6) | $t_R/t_F = 1.0ns$ | 25 | | MHz |

Note 4: Guaranteed by Design (GDB) by statistical analysis**Note 5:** $R_L = 500\Omega$ to GND, $C_L = 50pF$ to GND, $t_R/t_F = 2.5ns$, Frequency = 25MHz, $V_M = 1.5V$ **Note 6:** When sending vectors one-way to a target device on an LSP (such as in FPGA/PLD configuration/programming), the clock frequency may be increased above this specification. In Scan Mode (expecting to capture returning data at the LSP), the F_{MAX} must be limited to the above specification.

AC Electrical Characteristics: Stitcher Transparent Mode

Over recommended operating supply voltage and temperature ranges unless otherwise specified (Note 5).

| Symbol | Parameter | Conditions | Typ | Max | Units |
|--------------------------|------------------------------------------------------------------------------------------------------------------------------------|------------|-----|------|-------|
| t_{PHL} , t_{PLH} | Propagation Delay TDI _{B0} to TDO _{B1} , TDI _{B1} to TDO _{B0} | | | 12.5 | ns |
| t_{PHL} , t_{PLH} | Propagation Delay TDI _{B0} to TDO ₀₁ , TDI _{B1} to TDO ₀₁ | | | 12.5 | ns |
| t_{PHL} , t_{PLH} | Propagation Delay TDI _{LSPn} to TDO _{LSPn+1} | | | 12.5 | ns |
| t_{PHL} , t_{PLH} | Propagation Delay TMS _{B0} to TMS _{B1} , TMS _{B1} to TMS _{B0} | | | 12.5 | ns |
| t_{PHL} , t_{PLH} | Propagation Delay TMS _{B0} to TMS ₍₀₁₋₀₆₎ , TMS _{B1} to TMS ₍₀₁₋₀₆₎ | | | 12.5 | ns |
| t_{PHL} , t_{PLH} | Propagation Delay \overline{TRST}_{B0} to \overline{TRST}_{B1} , \overline{TRST}_{B1} to \overline{TRST}_{B0} | | | 12.5 | ns |
| t_{PHL} , t_{PLH} | Propagation Delay \overline{TRST}_{B0} to $\overline{TRST}_{(01-06)}$, \overline{TRST}_{B1} to $\overline{TRST}_{(01-06)}$ | | | 12.5 | ns |

Timing Diagrams

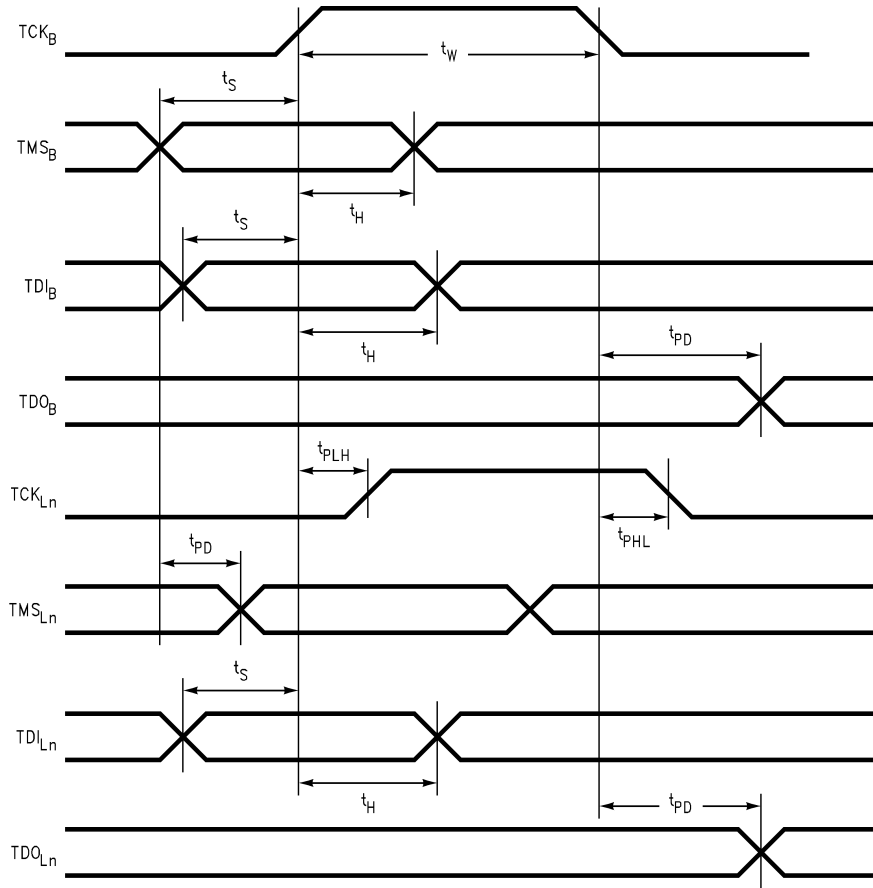

Waveforms for an Unparked STA112 in the Shift-DR (IR) TAP Controller State

20051236

Timing Diagrams (Continued)

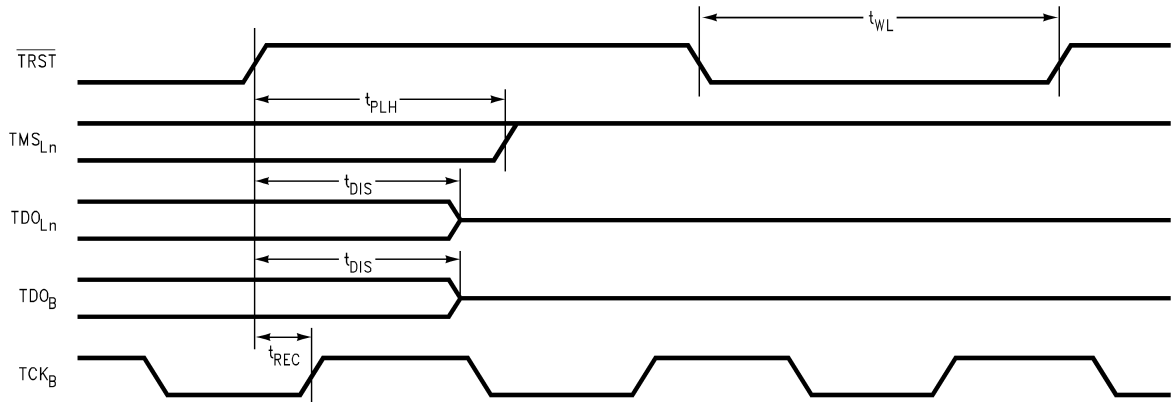

20051238

Reset Waveforms

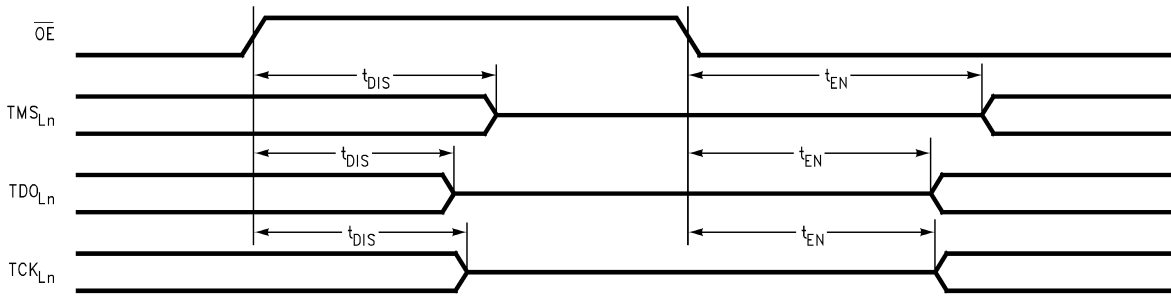

20051239

Output Enable Waveforms

Capacitance & I/O Characteristics

Refer to National's website for IBIS models at <http://www.national.com/scan>

Physical Dimensions inches (millimeters) unless otherwise noted

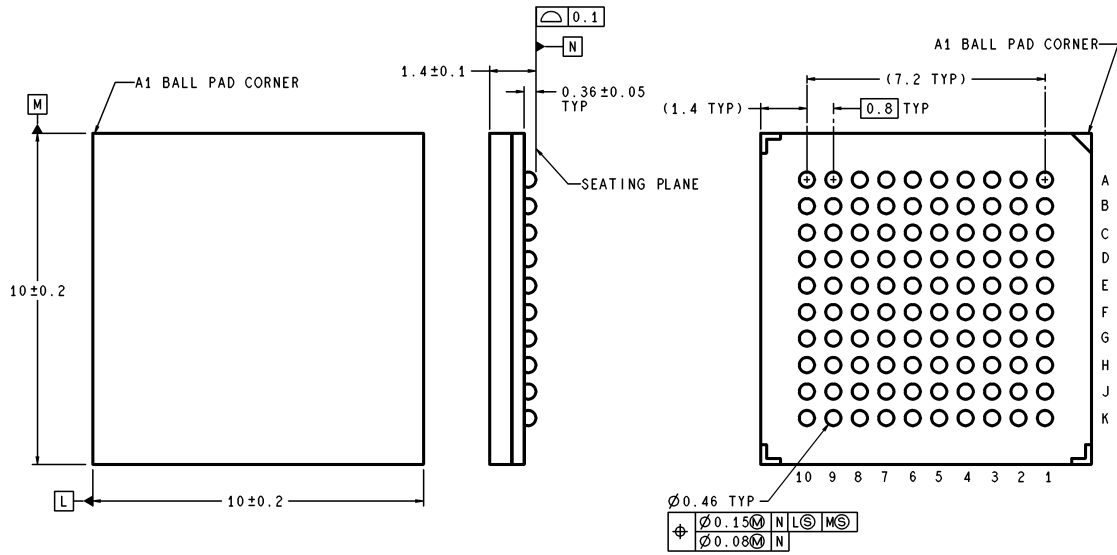

DIMENSIONS ARE IN MILLIMETERS

SLC100A (Rev B)

100-Pin BGA
NS Package Number SLC100a
Ordering Code SCANSTA112SM

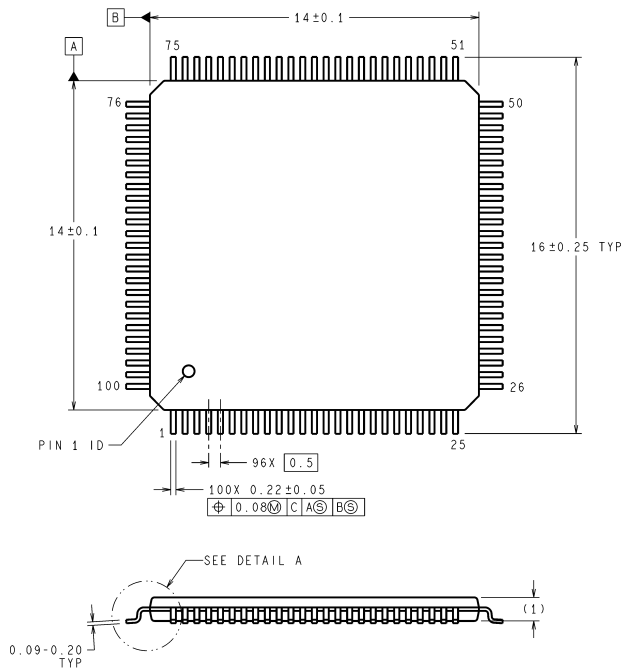

DIMENSIONS ARE IN MILLIMETERS
 DIMENSION IN () FOR REFERENCE ONLY

100-Pin TQFP
NS Package Number VJD100a
Ordering Code SCANSTA112VS

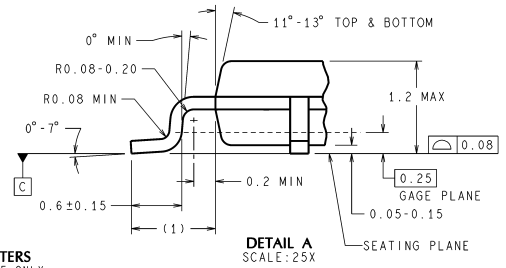
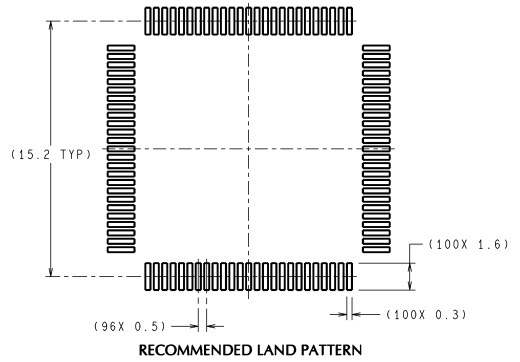

VJD100A (Rev C)

Notes

National does not assume any responsibility for use of any circuitry described, no circuit patent licenses are implied and National reserves the right at any time without notice to change said circuitry and specifications.

For the most current product information visit us at www.national.com.

LIFE SUPPORT POLICY

NATIONAL'S PRODUCTS ARE NOT AUTHORIZED FOR USE AS CRITICAL COMPONENTS IN LIFE SUPPORT DEVICES OR SYSTEMS WITHOUT THE EXPRESS WRITTEN APPROVAL OF THE PRESIDENT AND GENERAL COUNSEL OF NATIONAL SEMICONDUCTOR CORPORATION. As used herein:

- | | |
|----------------------------------------------------------------------------------------------------------------------------------------------------------------------------------------------------------------------------------------------------------------------------------------------------------------------------------------------------------|---------------------------------------------------------------------------------------------------------------------------------------------------------------------------------------------------------------------------------------------|
| <p>1. Life support devices or systems are devices or systems which, (a) are intended for surgical implant into the body, or (b) support or sustain life, and whose failure to perform when properly used in accordance with instructions for use provided in the labeling, can be reasonably expected to result in a significant injury to the user.</p> | <p>2. A critical component is any component of a life support device or system whose failure to perform can be reasonably expected to cause the failure of the life support device or system, or to affect its safety or effectiveness.</p> |
|----------------------------------------------------------------------------------------------------------------------------------------------------------------------------------------------------------------------------------------------------------------------------------------------------------------------------------------------------------|---------------------------------------------------------------------------------------------------------------------------------------------------------------------------------------------------------------------------------------------|

BANNED SUBSTANCE COMPLIANCE

National Semiconductor manufactures products and uses packing materials that meet the provisions of the Customer Products Stewardship Specification (CSP-9-111C2) and the Banned Substances and Materials of Interest Specification (CSP-9-111S2) and contain no "Banned Substances" as defined in CSP-9-111S2.

Leadfree products are RoHS compliant.



National Semiconductor
Americas Customer
Support Center
Email: new.feedback@nsc.com
Tel: 1-800-272-9959

National Semiconductor
Europe Customer Support Center
Fax: +49 (0) 180-530 85 86
Email: europe.support@nsc.com
Deutsch Tel: +49 (0) 69 9508 6208
English Tel: +44 (0) 870 24 0 2171
Français Tel: +33 (0) 1 41 91 8790

National Semiconductor
Asia Pacific Customer
Support Center
Email: ap.support@nsc.com

National Semiconductor
Japan Customer Support Center
Fax: 81-3-5639-7507
Email: jpn.feedback@nsc.com
Tel: 81-3-5639-7560

IMPORTANT NOTICE

Texas Instruments Incorporated and its subsidiaries (TI) reserve the right to make corrections, modifications, enhancements, improvements, and other changes to its products and services at any time and to discontinue any product or service without notice. Customers should obtain the latest relevant information before placing orders and should verify that such information is current and complete. All products are sold subject to TI's terms and conditions of sale supplied at the time of order acknowledgment.

TI warrants performance of its hardware products to the specifications applicable at the time of sale in accordance with TI's standard warranty. Testing and other quality control techniques are used to the extent TI deems necessary to support this warranty. Except where mandated by government requirements, testing of all parameters of each product is not necessarily performed.

TI assumes no liability for applications assistance or customer product design. Customers are responsible for their products and applications using TI components. To minimize the risks associated with customer products and applications, customers should provide adequate design and operating safeguards.

TI does not warrant or represent that any license, either express or implied, is granted under any TI patent right, copyright, mask work right, or other TI intellectual property right relating to any combination, machine, or process in which TI products or services are used. Information published by TI regarding third-party products or services does not constitute a license from TI to use such products or services or a warranty or endorsement thereof. Use of such information may require a license from a third party under the patents or other intellectual property of the third party, or a license from TI under the patents or other intellectual property of TI.

Reproduction of TI information in TI data books or data sheets is permissible only if reproduction is without alteration and is accompanied by all associated warranties, conditions, limitations, and notices. Reproduction of this information with alteration is an unfair and deceptive business practice. TI is not responsible or liable for such altered documentation. Information of third parties may be subject to additional restrictions.

Resale of TI products or services with statements different from or beyond the parameters stated by TI for that product or service voids all express and any implied warranties for the associated TI product or service and is an unfair and deceptive business practice. TI is not responsible or liable for any such statements.

TI products are not authorized for use in safety-critical applications (such as life support) where a failure of the TI product would reasonably be expected to cause severe personal injury or death, unless officers of the parties have executed an agreement specifically governing such use. Buyers represent that they have all necessary expertise in the safety and regulatory ramifications of their applications, and acknowledge and agree that they are solely responsible for all legal, regulatory and safety-related requirements concerning their products and any use of TI products in such safety-critical applications, notwithstanding any applications-related information or support that may be provided by TI. Further, Buyers must fully indemnify TI and its representatives against any damages arising out of the use of TI products in such safety-critical applications.

TI products are neither designed nor intended for use in military/aerospace applications or environments unless the TI products are specifically designated by TI as military-grade or "enhanced plastic." Only products designated by TI as military-grade meet military specifications. Buyers acknowledge and agree that any such use of TI products which TI has not designated as military-grade is solely at the Buyer's risk, and that they are solely responsible for compliance with all legal and regulatory requirements in connection with such use.

TI products are neither designed nor intended for use in automotive applications or environments unless the specific TI products are designated by TI as compliant with ISO/TS 16949 requirements. Buyers acknowledge and agree that, if they use any non-designated products in automotive applications, TI will not be responsible for any failure to meet such requirements.

Following are URLs where you can obtain information on other Texas Instruments products and application solutions:

Products

| | |
|------------------------|--------------------------------------------------------------------------------------|
| Audio | www.ti.com/audio |
| Amplifiers | amplifier.ti.com |
| Data Converters | dataconverter.ti.com |
| DLP® Products | www.dlp.com |
| DSP | dsp.ti.com |
| Clocks and Timers | www.ti.com/clocks |
| Interface | interface.ti.com |
| Logic | logic.ti.com |
| Power Mgmt | power.ti.com |
| Microcontrollers | microcontroller.ti.com |
| RFID | www.ti-rfid.com |
| OMAP Mobile Processors | www.ti.com/omap |
| Wireless Connectivity | www.ti.com/wirelessconnectivity |

Applications

| | |
|-------------------------------|------------------------------------------------------------------------------------------|
| Communications and Telecom | www.ti.com/communications |
| Computers and Peripherals | www.ti.com/computers |
| Consumer Electronics | www.ti.com/consumer-apps |
| Energy and Lighting | www.ti.com/energy |
| Industrial | www.ti.com/industrial |
| Medical | www.ti.com/medical |
| Security | www.ti.com/security |
| Space, Avionics and Defense | www.ti.com/space-avionics-defense |
| Transportation and Automotive | www.ti.com/automotive |
| Video and Imaging | www.ti.com/video |

TI E2E Community Home Page

e2e.ti.com

Mailing Address: Texas Instruments, Post Office Box 655303, Dallas, Texas 75265
Copyright © 2011, Texas Instruments Incorporated