

LM96511

LM96511 Ultrasound Receive Analog Front End (AFE)



Literature Number: SNAS476F

LM96511

Ultrasound Receive Analog Front End (AFE)

General Description

The LM96511 is an 8-channel integrated analog front end (AFE) module for multi-channel applications, particularly medical ultrasound. Each of the 8 signal paths consists of a low noise amplifier (LNA), a digitally programmable variable gain amplifier (DVGA) and a 12-bit, 40 to 50 Mega Samples Per Second (MSPS) analog-to-digital converter (ADC) with Instant Overload Recovery (IOR). The architecture of the DVGA is a digitally-controlled linear-in-dB step attenuator driving a fixed-gain post-amplifier (PA). The ADC uses a Continuous-Time-Sigma-Delta ($\Sigma\Delta$) architecture with digital decimation filtering to maximize dynamic performance and provide an alias free input bandwidth to $ADC\ CLK / 2$. The ADC digital outputs are serialized and provided on differential LVDS outputs. The ADC includes an on-chip clock cleaner PLL.

In addition, for baseband CW Doppler Beamformer applications, an 8-channel demodulator with 16 discrete phase rotation angles is included.

Selective power reduction is included to minimize consumption of idle sections during interleaved imaging modes.

An SPI™ compatible serial interface allows dynamic digital programming and control. National Semiconductor offers a full development package for sale which includes acquisition analysis hardware and software with user friendly GUI for device programming and control.

Features

- 8-channel LNA, DVGA, and 12-bit Continuous Time $\Sigma\Delta$ ADC
- Programmable Active Termination LNA
- 8-channel, integrated CW Doppler Beamformer
- Low-power consumption
- Embedded ADC Digital Filter
- ADC Instant Overload Recovery
- Embedded ADC “clock-cleaning” PLL
- 11 mm x 17 mm RoHS BGA Package

Key Specifications

(Full path unless noted)

B-Mode:

Total Input Voltage Noise (RTI)	0.9 nV/vHz
Max AFE Gain	58 dB
Single-Ended Input Swing	500mVpp
Programmable Maximum DVGA Attenuation	38, 36, 34, 32 dB
Programmable Post Amp Gain	31 or 38 dB
Attenuator Step Resolution	0.05 or 0.1 dB
ADC Resolution	12 bits
Conversion Rate (ADC CLK)	40 to 50 MSPS
ADC Digital Filter stop band attenuation	72 dB
ADC Digital Filter Passband Ripple	± 0.01 dB
ADC Instant Overload Recovery	1 ADC Clock Period
Power Consumption (per channel)	110 mW

CW Doppler Mode:

Phase Rotation Resolution	22.5 degrees
Phase Noise (Per Channel, Offset = 5KHz)	-144 dBc/Hz
Dynamic Range	-161 dB/Hz
Amplitude Quadrature Error (I to Q)	± 0.04 dB
Phase Quadrature Error (I to Q)	± 0.10°
Power Consumption (Per Channel)	208 mW

Common Specifications:

LNA Input Voltage Noise	0.82 nV/vHz
Operating temp. Range	0 to +70°C

Applications

- Ultrasound Imaging
- Communications
- Portable Instrumentation
- Sonar

Simplified LM96511 Block Diagram

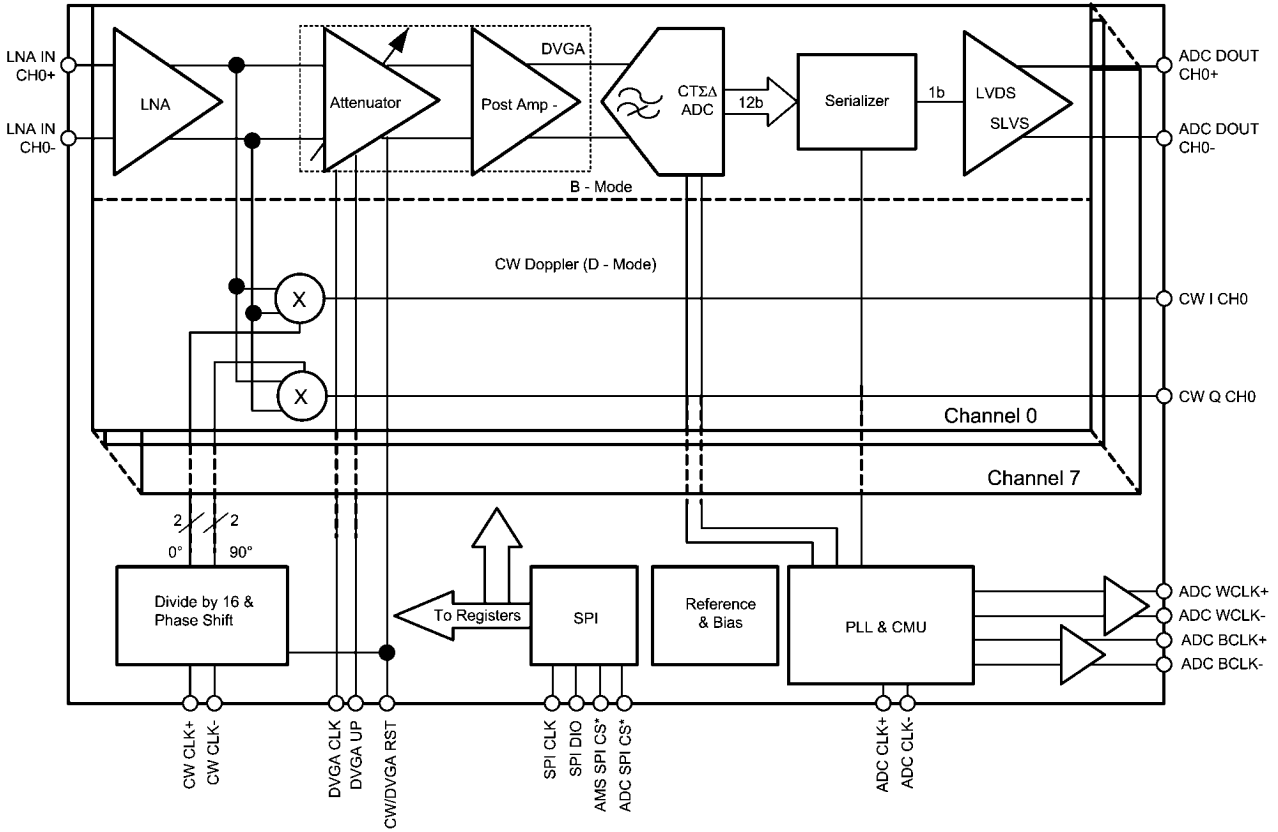

30087001

FIGURE 1. Simplified LM96511 Block Diagram

Typical Application

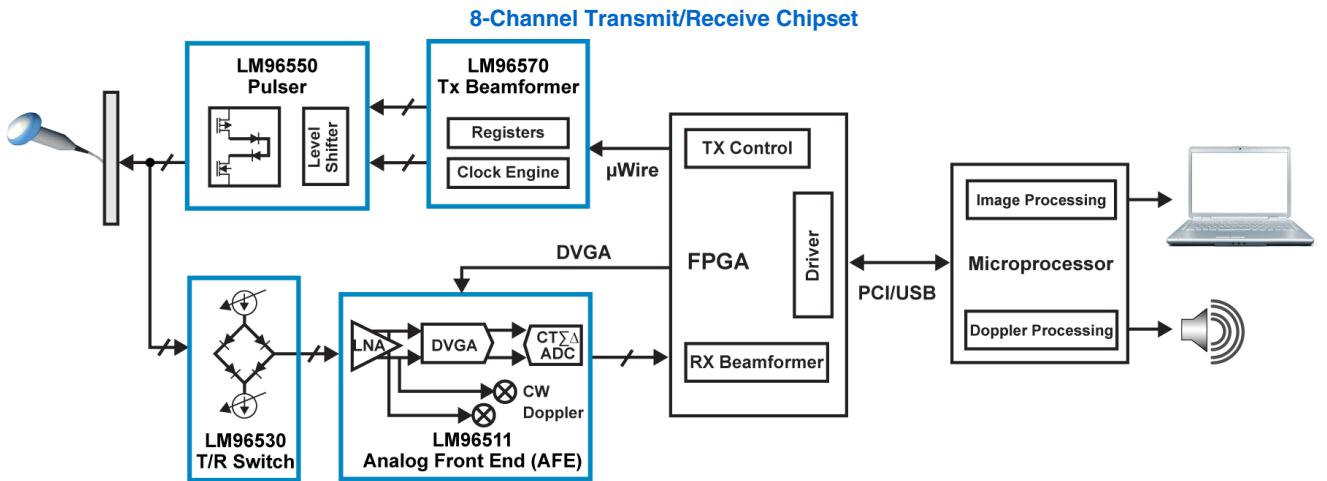

30087010

Table of Contents

General Description	1
Features	1
Key Specifications	1
Applications	1
Simplified LM96511 Block Diagram	2
Typical Application	2
Connection Diagrams	5
Ordering Information	6
Pin Descriptions	7
Absolute Maximum Ratings	12
Operating Ratings	12
AFE Electrical Characteristics (B-Mode)	12
LNA Electrical Characteristics	15
DVGA Electrical Characteristics	15
ADC Electrical Characteristics	16
Digital Input and Output Characteristics	17
Timing Diagrams	21
Typical Performance Characteristics	23
CW Doppler Plots	27
Overview	29
LNA INPUT AMPLITUDE RANGE	29
TYPICAL INPUT CONFIGURATION	29
PROGRAMMABLE INPUT IMPEDANCE & LNA GAIN SELECTION	30
OFFSET SOFT-TRIM	31
DYNAMIC RANGE	31
DVGA OPERATION	32
DVGA Half Step Mode	36
DVGA CLK Pin	37
CW/DVGA RST Pin	37
DVGA UP Pin:	37
DVGA Accelerated Gain Adjustment:	37
THE LM96511 ADC	37
ADC OUTPUT INTERFACE	38
12-BIT SIGMA DELTA ($\Sigma\Delta$) ADC CORE	39
INSTANT OVERLOAD RECOVERY	39
USING IOR ON MODE	39
Standard Use of IOR On Mode	39
Advanced Use of IOR On Mode	39
INTEGRATED PRECISION LC PLL ADVANTAGES	40
DIGITAL DECIMATION FILTER AND EQUALIZER	40
OUTPUT CLOCK SYNCHRONIZATION ACROSS MULTIPLE CHIPS	41
CAPACITOR SELECTION	41
ADC OUTPUT CONSIDERATIONS	42
Output Driving Voltage, ADC IO DVDD	42
Output Modes and Output Common Mode	42
Termination	42
LVDS Output Training Sequences	42
The Voltage Reference	43
CW Doppler Section Theory of Operation	44
CW DOPPLER NOISE ANALYSIS	45
CW DOPPLER 16x LO SOURCE IMPLEMENTATION	46
LM96511 Power Management	48
POWER-UP SEQUENCING	48
SPI™ Interface	50
THE SERIAL PERIPHERAL INTERFACE	50
ACCESS TO THE SERIAL PERIPHERAL INTERFACE	50
CONNECTING MULTIPLE LM96511 DEVICES TOGETHER	51
SERIAL PERIPHERAL INTERFACE READ AND WRITE SPEED	51
SPI™ Register Map	52
SPI™ Register Map Notes	54
Physical Dimensions	62

List of Figures

FIGURE 1. Simplified LM96511 Block Diagram	2
--	---

FIGURE 2. 376–Pin BGA Package Top View (18 Rows by 32 Columns)	5
FIGURE 3. Intermodulation Distortion Measurement with Unequal Tones	19
FIGURE 4. CW Doppler Phase Noise Measurement	20
FIGURE 5. B-Mode ADC Data Output Timing	21
FIGURE 6. B-Mode ADC Data Output Level Definitions	21
FIGURE 7. CW CLK Level Definitions	21
FIGURE 8. SPI™ Write Timing	22
FIGURE 9. SPI™ Read Timing	22
FIGURE 10. CW/DVGA RST Timing (CW Doppler Mode)	22
FIGURE 11. Ultra-Sound System Block Diagram	29
FIGURE 12. Signal Path (B-Mode) Single Channel Including Input Clamp and Diode Bridge	30
FIGURE 13. Standard Input Termination	30
FIGURE 14. Active Termination Schematic	31
FIGURE 15. Offset Distribution Histogram including Soft-Trim Improvement	31
FIGURE 16. LM96511 in Typical TGC Operation at 5MHz	32
FIGURE 17. Periodic TGC Ramp: Example 1 (Half-Step Disable bit = 1)	33
FIGURE 18. DVGA UP bit Change (Half-Step Disable bit = 1)	33
FIGURE 19. Periodic TGC Ramp: Example 2 (Half Step Disable bit = 1)	34
FIGURE 20. Basic Gain Adjustment (Half Step Disable Bit = 1)	34
FIGURE 21. Accelerated Gain Adjustment (Half Step Disable bit = 1)	35
FIGURE 22. Gain Reset with DVGA UP bit = 0	35
FIGURE 23. DVGA Gain control “Micro Illustration” of the Gain Stair Case	36
FIGURE 24. LM96511 ADC Block Diagram	38
FIGURE 25. ADC WCLK	39
FIGURE 26. PLL Phase Noise Transfer Function: ADC CLK = 40 MHz	40
FIGURE 27. PLL Phase Noise Transfer Function: ADC CLK = 50 MHz	40
FIGURE 28. Digital Filter Transfer Function	41
FIGURE 29. Group Delay with Equalizer Off	41
FIGURE 30. Group Delay with Equalizer On	41
FIGURE 31. DAC LPF Capacitor	41
FIGURE 32. LVDS Training Sequence	43
FIGURE 33. Reference Sharing	43
FIGURE 34. Signal Path (CW Doppler) Single Channel	44
FIGURE 35. I-V with Integrated 2–Pole LFP	45
FIGURE 36. CW Doppler LPF Gain/Phase Characteristics	45
FIGURE 37. CW Doppler Output (I or Q) Implementation (64 Receive Channels)	46
FIGURE 38. CW Doppler Low-Phase Noise Clock Source Design	47
FIGURE 39. LM3881 Power Sequencer Can be Used for Proper LM96511 Power-Up	49
FIGURE 40. SPI™ Bus Master Slave Connection	50
FIGURE 41. SPI™ Compatible Read/Write Timing Diagram	51
FIGURE 42. SPI™ Compatible Interconnect for Multiple LM96511's (Open Drain Mode)	51

List of Tables

TABLE 1. ADC Output Mode Summary	42
TABLE 2. LM96511 Power Consumption for Various Conditions	48
TABLE 3. DGF To Digital Gain Look-Up Table	58
TABLE 4. DVGA Initial Attenuation Truth Table	60
TABLE 5. DVGA Notation	61
TABLE 6. Offset Trim “Write” Truth Table	61
TABLE 7. Offset Trim “Write” and “Read” Example	61

Connection Diagrams

	1	2	3	4	5	6	7	8	9	10	11	12	13	14	15	16	
A	LNA PD	DVGA PD	AMP RST	AMP SPI CS	ADC SPI CS	DVGA INIT MSB	AMP DVDD	AMP DGND	AGND	AMP AVCC A	CW I CH7	AGND	AGND	CW DGND	CW DGND	AGND	A
B	DVGA PA HI	CW AVCC	SPI CLK	SPI DIO	DVGA INIT LSB	AMP IO DVDD	AMP DVDD	AMP AVCC A	DVGA BYP CH7	CW AVCC	CW Q CH7	CW DGND	CW DGND	CW AVCC	CW AVCC	CW I CH6	B
C	NC	CW AVCC	AGND	NC										CW AVCC	DVGA BYP CH6	AMP AVCC A	C
D	LNA IN CH7-	LNA IN CH7+	AGND	LNA OUT CH7-										AMP AVCC A	AMP AVCC A	DVGA BYP CH5	D
E	LNA IN CH6+	CW AVCC	NC	AMP AVCC A										AMP AVCC A	CW I CH5	CW AVCC	E
F	LNA OUT CH6-	LNA IN CH6-	AGND	CW AVCC			AMP THRM GND	AMP THRM GND	AMP THRM GND	AMP THRM GND	AMP THRM GND			CW Q CH5	CW DGND	CW DGND	F
G	LNA IN CH5+	NC	AMP AVCC A	CW AVCC			AMP THRM GND	AMP THRM GND	AMP THRM GND	AMP THRM GND	AMP THRM GND			CW Q CH4	CW AVCC	CW I CH4	G
H	LNA OUT CH5-	LNA IN CH5-	AGND	CW AVCC			AMP THRM GND	AMP THRM GND	AMP THRM GND	AMP THRM GND	AMP THRM GND			AMP DGND	CW AVCC	AMP DVDD	H
J	LNA IN CH4+	NC	AMP AVCC A	CW AVCC			AMP THRM GND	AMP THRM GND	AMP THRM GND	AMP THRM GND	AMP THRM GND			CW CLK+	CW CLK-	AMP AVCC A	J
K	LNA OUT CH4-	LNA IN CH4-	AGND	CW AVCC			AMP THRM GND	AMP THRM GND	AMP THRM GND	AMP THRM GND	AMP THRM GND			DVGA CLK	CW/DVGA RST	AMP CWDVGA	K
L	LNA IN CH3+	NC	AMP AVCC A	CW AVCC			AMP THRM GND	AMP THRM GND	AMP THRM GND	AMP THRM GND	AMP THRM GND			AMP IO DVDD	DVGA BYP CH3	AMP AVCC A	L
M	LNA OUT CH3-	LNA IN CH3-	AGND	AMP AVCC A			AMP THRM GND	AMP THRM GND	AMP THRM GND	AMP THRM GND	AMP THRM GND			CW AVCC	CW AVCC	CW I CH3	M
N	LNA IN CH2+	CW AVCC	NC	AMP AVCC A			AMP THRM GND	AMP THRM GND	AMP THRM GND	AMP THRM GND	AMP THRM GND			CW Q CH3	CW DGND	CW DGND	N
P	LNA OUT CH2-	LNA IN CH2-	AGND	CW AVCC										AGND	CW I CH2	CW AVCC	P
R	LNA IN CH1+	NC	AMP AVCC A	AGND										AMP AVCC A	AMP AVCC A	DVGA BYP CH2	R
T	LNA OUT CH1-	LNA IN CH1-	CW AVCC	AMP AVCC A										AMP AVCC A	AMP AVCC A	CW AVCC	T
U	LNA IN CH0+	NC	AGND	AMP AVCC A	AMP DGND	AGND	AMP AVCC A	AMP AVCC A	CW AVCC	CW Q CH0	CW DGND	AGND	AMP AVCC A	AMP DVDD	AMP DVDD	CW AVCC	U
V	LNA IN CH0-	LNA OUT CH0-	AGND	AMP AVCC A	AMP DVDD	AMP AVCC A	NC	DVGA BYP CH0	CW AVCC	CW I CH0	AGND	AGND	AMP AVCC A	CW I CH1	AGND	CW DGND	V
	1	2	3	4	5	6	7	8	9	10	11	12	13	14	15	16	

30087002

	17	18	19	20	21	22	23	24	25	26	27	28	29	30	31	32	
A	CW Q CH6	NC	ADC AVDD	NC	NC	ADC CLK-	AGND	AGND	AGND	ADC DVDD	ADC IO DGND	ADC IO DGND	ADC WCLK-	ADC WCLK+	ADC BCLK-	ADC BCLK+	A
B	AGND	NC	AGND	AGND	AGND	ADC CLK+	AGND	AGND	ADC DVDD	ADC DVDD	ADC IO DGND	ADC IO DGND	AGND	ADC IO DVDD	AGND	ADC DOUT CH7-	B
C	AMP AVCC A	ADC AVDD	AGND												AGND	ADC DOUT CH7+	C
D	AMP AVCC A	AGND	AGND												ADC IO DGND	ADC DOUT CH6-	D
E	CW AVCC	NC	NC												ADC IO DGND	ADC DOUT CH6+	E
F	AGND	ADC AVDD	AGND				ADC THRM GND	ADC THRM GND	ADC THRM GND	ADC THRM GND	ADC THRM GND				AGND	ADC DOUT CH5-	F
G	AGND	AGND	AGND				ADC THRM GND	ADC THRM GND	ADC THRM GND	ADC THRM GND	ADC THRM GND				ADC IO DVDD	ADC DOUT CH5+	G
H	AMP DVDD	NC	NC				ADC THRM GND	ADC THRM GND	ADC THRM GND	ADC THRM GND	ADC THRM GND				ADC IO DVDD	ADC DOUT CH4-	H
J	DVGA BYP CH4	ADC AVDD	AGND				ADC THRM GND	ADC THRM GND	ADC THRM GND	ADC THRM GND	ADC THRM GND				AGND	ADC DOUT CH4+	J
K	AMP AVCC A	NC	AGND				ADC THRM GND	ADC THRM GND	ADC THRM GND	ADC THRM GND	ADC THRM GND				AGND	ADC DOUT CH3-	K
L	DVGA UP	AGND	NC				ADC THRM GND	ADC THRM GND	ADC THRM GND	ADC THRM GND	ADC THRM GND				AGND	ADC DOUT CH3+	L
M	AGND	AGND	ADC AVDD				ADC THRM GND	ADC THRM GND	ADC THRM GND	ADC THRM GND	ADC THRM GND				ADC IO DGND	AGND	M
N	AGND	AGND	NC				ADC THRM GND	ADC THRM GND	ADC THRM GND	ADC THRM GND	ADC THRM GND				ADC IO DGND	ADC DOUT CH2-	N
P	CW Q CH2	AGND	NC												AGND	ADC DOUT CH2+	P
R	CW AVCC	AGND	ADC AVDD												AGND	NC	R
T	DVGA BYP CH1	AGND	AGND												NC	ADC DOUT CH1-	T
U	AMP DGND	NC	ADC AVDD	NC	AGND	AGND	ADC RREF	ADC AVDD	ADC RST	ADC AVDD	ADC DVDD	ADC AVDD	ADC IO DGND	AGND	ADC IO DVDD	ADC DOUT CH1+	U
V	CW Q CH1	NC	AGND	NC	ADC VREF GND	ADC VREF	ADC LPF BYP	AGND	AGND	ADC CWDVGA	ADC AVDD	ADC DVDD	ADC AVDD	ADC IO DGND	ADC DOUT CH3+	ADC DOUT CH0-	V
	17	18	19	20	21	22	23	24	25	26	27	28	29	30	31	32	

30087011

FIGURE 2. 376-Pin BGA Package Top View (18 Rows by 32 Columns)

Ordering Information

Order Number	Package Type	NSC Package Drawing	Supplied As
LM96511CCSM NOPB	TFBGA 376	SLM376A	Trays

SPI™ is a trademark of Motorola Inc.

TRI_STATE® is a registered trademark of National Semiconductor Corporation.

Pin Descriptions

Ball Id. (Row_Column)	Pin Name	Function	Description		
Amplifier Signals					
U1	LNA IN CH0+	Input	LNA Non-Inverting Input		
R1	LNA IN CH1+				
N1	LNA IN CH2+				
L1	LNA IN CH3+				
J1	LNA IN CH4+				
G1	LNA IN CH5+				
E1	LNA IN CH6+				
D2	LNA IN CH7+		LNA Inverting Input		
V1	LNA IN CH0-				
T2	LNA IN CH1-				
P2	LNA IN CH2-				
M2	LNA IN CH3-				
K2	LNA IN CH4-				
H2	LNA IN CH5-				
F2	LNA IN CH6-		Output	LNA Inverting Output	
D1	LNA IN CH7-				
V2	LNA OUT CH0-				
T1	LNA OUT CH1-				
P1	LNA OUT CH2-				
M1	LNA OUT CH3-				
K1	LNA OUT CH4-				
H1	LNA OUT CH5 -	Bypass	Decoupling Capacitor to Analog Ground		
F1	LNA OUT CH6-				
D4	LNA OUT CH7-				
V8	DVGA BYP CH0				
T17	DVGA BYP CH1				
R16	DVGA BYP CH2				
L15	DVGA BYP CH3				
J17	DVGA BYP CH4	Output	CW DOPPLER In-Phase output current		
D16	DVGA BYP CH5				
C15	DVGA BYP CH6				
B9	DVGA BYP CH7				
J14	CW CLK+			Input	CW DOPPLER Differential Input Clock + CW DOPPLER Differential Input Clock -
J15	CW CLK-				
V10	CW I CH0			Output	
V14	CW I CH1				
P15	CW I CH2				
M16	CW I CH3				
G16	CW I CH4				
E15	CW I CH5				
B16	CW I CH6				
A11	CW I CH7				

Ball Id. (Row_Column)	Pin Name	Function	Description
U10	CW Q CH0	Output	CW DOPPLER Quadrature-Phase output current
V17	CW Q CH1		
P17	CW Q CH2		
N14	CW Q CH3		
G14	CW Q CH4		
F14	CW Q CH5		
A17	CW Q CH6		
B11	CW Q CH7		
Amplifier Controls			
K14	DVGA CLK	Input	DVGA GAIN Clock
L17	DVGA UP		1 = Increment DVGA gain 0 = Decrement DVGA gain
A6	DVGA INIT MSB		DVGA Initial Gain Control. Sets the initial DVGA gain. See application section.
B5	DVGA INIT LSB		
K15	CW/DVGA RST		1 = CW DOPPLER Phase and DVGA Gain Reset
K16	AMP CW/DVGA		0 = B-mode 1 = CW DOPPLER mode
A1	LNA PD		1 = LNA Power-down
A2	DVGA PD		1 = DVGA Power-down
A3	AMP RST		1 = Reset all Amplifier SPI™ Registers
B1	DVGA PA HI		
ADC Signals			
B22 A22	ADC CLK+ ADC CLK-	Input	Differential Input Clock. The input clock must lie in the range of 40 MHz to 50 MHz. It is used by the PLL to generate the internal sampling clocks .
V31	ADC DOUT CH0+	Output	Differential Serial Outputs for channels 0 to 7. Each pair of outputs provides the serial output for the specific channel. The default output is LVDS format, but programming the appropriate control registers, the output format can be changed to SLVS . By programming TX_term (bit 4) in the LVDS Control register, it is possible to internally terminate these outputs with 100Ω resistors.
U32	ADC DOUT CH1+		
P32	ADC DOUT CH2+		
L32	ADC DOUT CH3+		
J32	ADC DOUT CH4+		
G32	ADC DOUT CH5+		
E32	ADC DOUT CH6+		
C32	ADC DOUT CH7+		
V32	ADC DOUT CH0-		
T32	ADC DOUT CH1-		
N32	ADC DOUT CH2-		
K32	ADC DOUT CH3-		
H32	ADC DOUT CH4-		
F32	ADC DOUT CH5-		
D32	ADC DOUT CH6-		
B32	ADC DOUT CH7-		

Ball Id. (Row_Column)	Pin Name	Function	Description
A30 A29	ADC WCLK+ ADC WCLK-	Output	Word Clock. Differential output frame clock used to indicate the bit boundary of each data sample. Information on timing can be seen in the Electrical Specifications section of the datasheet. By programming TX_term (bit 4) in the LVDS Control register, it is possible to internally terminate these outputs with 100Ω resistors.
A32 A31	ADC BCLK+ ADC BCLK-		Bit clock. Differential output clock used for sampling the serial outputs. Information on timing can be seen in the Electrical Specifications section of the datasheet. By programming TX_term (bit 4) in the LVDS Control register, it is possible to internally terminate these outputs with 100Ω resistors.
ADC Controls			
U25	ADC RST	Input	This pin is an active low reset for the entire ADC, both analog and digital components. The pin must be held low for 500 ns then returned to high in order to ensure that the chip is reset correctly.
V26	ADC CW/DVGA	Input	0 = B-mode 1 = CW DOPPLER mode, PLL and References are still active to minimize recovery time.
V22	ADC VREF		ADC Optional External Reference Voltage; Improves channel-to-channel and converter-to-converter matching.
V21	ADC VREF GND		If Internal Reference is used, connect to AGND.
U23	ADC RREF	Output	External 10k ±1% resistor to ADC Analog GND. Used to set internal bias currents. Required regardless of the type of reference used.
V23	ADC LPF BYP	Bypass	Capacitor required by the Modulator DAC's LP Filter. Must be at least 100 nF to ADC Analog GND. Can be increased to 10 μF to minimize close-in phase noise.
SPI™ Compatible Interface			
B3	SPI™ CLK	Input	SPI™ clock
B4	SPI™ DIO	Input/Output	SPI™ Data Input/Output
A5	ADC SPI™ CS	Input	0 = ADC SPI™ Chip Select
A4	AMP SPI™ CS		0 = Amplifier SPI™ Chip Select.

Ball Id. (Row_Column)	Pin Name	Function	Description
Power and Ground			
A10, B8, C16, C17, D14, D15, D17, E4, E14, G3, J3, J16, K17, L3, L16, M4, N4, R3, R14, R15, T4, T14, T15, U4, U7, U8, U13, V4, V6, V13	AMP AVCC A	Power	Amplifier Analog Power Nominally +3.3V.
B10, B14, B15, C14, E16, E17, H15, G15, M14, M15, P16, R17, T16, U9, U16, V9, B2, C2, E2, F4, G4, H4, J4, K4, L4, N2, P4, T3	CW AVCC		CW DOPPLER Analog Power Nominally +5.0V.
V5, A7, B7, H16, H17, U14, U15	AMP DVDD		DVGA Digital Power. Nominally +3.3V.
B6, L14	AMP IO DVDD		Amplifier IO Digital Power. Connect to ADC IO DVDD. Nominally +1.2V.
B30, G31, H31, U31	ADC IO DVDD		ADC IO Digital Power. Nominally +1.2V.
A19, C18, F18, J18, M19, R19, U19, U24, U26, U28, V27, V29	ADC AVDD		ADC Analog Power. Nominally +1.2V.
A26, B25, B26, U27, V28	ADC DVDD		ADC Digital Power. Nominally +1.2V .

Ball Id. (Row_Column)	Pin Name	Function	Description
A9, A12, A13, A16, A23, A24, A25, B17, B19, B20, B21, B23, B24, B29, B31, C3, C19, C31, D3, D18, D19, F3, F17, F19, F31, G17, G18, G19, H3, J19, J31, K3, K19, K31, L18, L31, M3, M17, M18, M32, N17, N18, P3, P14, P18, P31, R4, R18, R31, T18, T19, U3, U6, U12, U21, U22, U30, V3, V11, V12, V15, V19, V24, V25	AGND	Ground	Analog Ground
F7, F8, F9, F10, F11, G7, G8, G9, G10, G11, H7, H8, H9, H10, H11, J7, J8, J9, J10, J11, K7, K8, K9, K10, K11, L7, L8, L9, L10, L11, M7, M8, M9, M10, M11, N7, N8, N9, N10, N11	AMP THRM GND		Thermal Ground (Connect to AGND)
F23, F24, F25, F26, F27, G23, G24, G25, G26, G27, H23, H24, H25, H26, H27, J23, J24, J25, J26, J27, K23, K24, K25, K26, K27, L23, L24, L25, L26, L27. M23, M24, M25, M26, M27, N23, N24, N25, N26, N27	ADC THRM GND		Digital Ground
A14, A15, B12, B13, F15, F16, N15, N16, U11, V16	CW DGND		Digital Ground
A8, H14, U5, U17	AMP DGND		
A27, A28, B27, B28, D31, E31, M31, N31, U29, V30	ADC IO DGND		
No Connect			
Important: "NC" pins should be left unconnected. Any connection to these pins could affect performance and functionality.			
A18, A20, A21, B18, C1, E3, E18, E19, G2, H18, H19, J2, K18, L2, L19, N3, N19, P19, R2, U2, U18, U20, V18, V20, R32, T31, V7, C4	NC		Do Not Connect

Absolute Maximum Ratings *(Note 1)*

If Military/Aerospace specified devices are required, please contact the National Semiconductor Sales Office/Distributors for availability and specifications.

Storage Temperature Range	TBD	Supply Voltage (AMP AVCC A, AMP DVDD)	+3.13V to 3.47V
Supply Voltage (CW AVCC)	-0.3V and +6V	Supply Voltage (ADC AVDD, ADC DVDD)	+1.14V to +1.26V
Supply Voltage (AMP AVCC A, AMP DVDD)	-0.3V and +3.63V	IO Supply Voltage (AMP IO DVDD, ADC io DVD)	+1.14V to +1.89V
Supply Voltage (ADC AVDD, ADC DVDD)	-0.3V and +1.44V	Analog Inputs	TBD
IO Supply Voltage (AMP IO DVDD, ADC IO DVDD)	-0.3V and +2.0V	SPI™ Compatible Inputs (SPI™ CLK, SPI™ DIO, AMP SPI™ CS, ADC SPI™ CS)	+1.14V to +1.89V
Voltage at Analog Inputs	-0.3V and +2.0V	ADC CLK Input Frequency	40 to 50 MHz
Voltage at SPI™ Compatible inputs (SPI™ CLK, SPI™ DIO, AMP SPI™ CS, ADC SPI™ CS)	-0.3V and +2.0V	ADC CLK Duty Cycle	30 to 70%
Input Current at any pin other than a Supply Voltage and LNA Inputs	25 mA	DVGA CLK Frequency	< 100 MHz
LNA Inputs	2.6 Vpp & ±10 mA	Ground Difference IAGND - DGNDI	50 mV
		ESD Tolerance(<i>Note 19</i>):	
		Human Body Model	1500V
		Machine Model	100V
		Charge Device Model	750V

Operating Ratings

(Note 1)

Operation Temperature Range	0°C to +70°C
Supply Voltage (CW AVCC)	+4.75V to +5.25V

AFE Electrical Characteristics (B-Mode)

Unless otherwise noted, specified limits apply for AMP AVCC A = **3.3V**, CW AVCC = **5V**, AMP IO DVDD = ADC IO DVDD = **1.2V**, ADC AVDD = ADC DVDD = **1.2V**, Full Scale ADC Output with RF Input at 5 MHz, DVGA PA HI = LO; AMP CW/DVGA pin = ADC CW/DVGA pin = LO, $F_{CLK} = 40$ MSPS; Clock duty cycle stabilization enabled; IOR On Mode. All 8 channels powered. **Boldface limits** apply for $T_A = T_{MIN}$ to T_{MAX} ; All other limits apply for $T_A = +25^\circ\text{C}$.

Parameter	Conditions	Min	Typ	Max	Units
Total Input (RTI) Voltage Noise	See , No Active Feedback, Input AC shorted to ground		0.9		nV/ $\sqrt{\text{Hz}}$
Noise Figure	Equivalent 50 Ω termination using Active Feedback ($R_{FB} = 301\Omega$)		3.7		dB
Single-Ended LNA Input Swing	1 dB SNR Loss (TGC in Operation). See (<i>Note 2</i>) & (<i>Note 22</i>)		380		mV _{PP}
Externally Programmable Input Resistance Range (overall)		50		2k	Ω
Offset Related Full Scale Amplitude Loss	Max DVGA Gain. 1 δ , See (<i>Note 18</i>)		-0.23		dB
	Max DVGA Gain, IOR Off Mode. 1 δ , See (<i>Note 18</i>)		-0.15		
Offset Tempco			-0.22		LSB/ $^\circ\text{C}$
Overload Recovery	Max DVGA Gain, Error < $\pm 1\%$		$1/f_{CLK}$		seconds
	Max DVGA Gain, Error < $\pm 1\%$		$1/f_{CLK}$		seconds
Ch-Ch Gain Match	Worst case across DVGA Gain Range		± 0.06	± 0.2	dB
Ch-Ch Phase Match	Worst case across DVGA Gain Range		± 0.35	± 0.75	$^\circ\text{C}$
Ch-Ch Group Delay Match			± 0.20	± 0.80	ns
Ch-Ch Crosstalk	Min DVGA Gain. See (<i>Note 9</i>)		-61		dBc
	Min DVGA Gain. See (<i>Note 9</i>)		-62		
	Min DVGA Gain. See (<i>Note 9</i>)		-62		
Bandwidth	-3 dB, Small Signal		$f_{CLK}/2$		MHz

Parameter	Conditions	Min	Typ	Max	Units
SNR	Mid DVGA gain, -6dB FS, DVGA PA HI pin= LO	60	63		dBFS
	Mid DVGA gain, -1dB FS, DVGA PA HI pin= LO		62		
	Mid DVGA gain, -6dB FS, DVGA PA HI pin= HI		57		
	Mid DVGA gain, -1dB FS, DVGA PA HI pin= HI		56		
HD2	$f_{in} = 5$ MHz, -6dBFS, Mid DVGA Gain		-72	-60	dBFS
	$f_{in} = 5$ MHz, -1dBFS, Mid DVGA Gain		-68		
HD3	$f_{in} = 5$ MHz, -6dBFS, Mid DVGA Gain		-52		dBFS
	$f_{in} = 5$ MHz, -1dBFS, Mid DVGA Gain		-43		
DVGA Clock Feedthrough	DVGA CLK frequency = 7.5MHz		-95		dBFS
AM Sidebands	Half Step Disabled		TBD		dBFS
	Half Step Enabled		TBD		
Spurious Noise near f_{in} , $f_{in} \pm (3/8 \times f_{in})$	$f_{in} = 2$ to 20 MHz		-84		dBFS
Spurious Noise near $2f_{in}$, $2 \times f_{in} \pm (3/4 \times f_{in})$			-83		dBFS
SFDR	$f_{in} = 5$ MHz, -6 dBFS, Mid DVGA Gain		88		dBFS
	$f_{in} = 5$ MHz, -1 dBFS, Mid DVGA Gain		82		
Power Consumption	Active Mode, IO DVDD = 1.2V		880	910	mW
	Active Mode, IO DVDD = 1.8V		905		
	Power Down		50		
Power Supply Current	AMP AVCC = 3.3V		155		mA
	AMP DVDD = 3.3V		1.6		
	CW AVCC = 5.0V		3.2		
	ADC AVDD = 1.2V		147		
	ADC DVDD = 1.2V		104		
	IO DVDD = 1.2V		35		
Wake-up Time	From Stand-By (From CW DOPPLER to B Mode when AMP CW/DVGA pin is switched from HI to LO). See (Note 17)		15	20	μ s

CW Doppler Electrical Characteristics

Unless otherwise noted, specified limits apply for AMP AVCC A = **3.3V**, CW AVCC = **5V**, AMP IO DVDD = ADC IO DVDD = **1.2V**, ADC AVDD = ADC DVDD = **1.2V**; Full Scale ADC Output with RF Input at 5 MHz; CW CLK = 80 MHz (LVPECL levels), AMP CW/DVGA pin = ADC CW/DVGA = HI. **Boldface limits** apply for $T_A = T_{MIN}$ to T_{MAX} ; All other limits apply for $T_A = +25^\circ\text{C}$.

Parameter	Conditions	Min	Typ	Max	Units
Phase Noise	$f_{\text{OFFSET}} = 5\text{kHz}$ with LNA Input = 240 mV _{PP} @ 5 MHz. See (Note 6)		-144		dBc/Hz
Dynamic Range (DNR)	IP1dB referred to RTI Noise		-161		dB/Hz
RTI Noise			1.2		nV/ $\sqrt{\text{Hz}}$
Single-Ended LNA Input Swing	1dB Compression (CW Doppler Mode). (IP1dB). See (Note 2) & (Note 22)		500		mV _{PP}
Phase Rotation Resolution	16 dynamically selectable angles		22.5		degrees
Phase Temperature Coefficient	I or Q. See (Note 7)		± 20		milli°C
Phase Quadrature Accuracy	I to Q. $\pm 6\delta$. See (Note 7) & (Note 12)		± 0.10		°C
Phase Match	I to I or Q to Q. See (Note 8) & (Note 12)		± 0.35		°C
Amplitude Match	I to Q. See (Note 8) & (Note 12)		± 0.04		dB
Amplitude Temperature Coefficient	I or Q. See (Note 7)		± 11		mdB/°C
CW CLK Input Freq Range	See (Note 11)	12		240	MHz
RF Input Freq Range	CW CLK = 16 x RF Input frequency. See (Note 11)	0.7		15	MHz
Third order IMD (IMD3)	Equal tones (f1 = 10 KHz offset, f2 = 15 KHz offset). See (Note 14)		-72		dBc
	Unequal tones. (f1 = 10 KHz offset, f2 = 15 KHz offset). See (Note 14)		-50		
Channel-to-Channel Crosstalk	"I" or "Q" output of undriven channel relative to driven channel		-95		dBc
Output Signal Current	I or Q, Per Channel, LNA Input = 380mV _{PP}	± 3.9	± 4.2	± 4.5	mA
Output Noise Current Density	$f_{\text{OFFSET}} = 5\text{kHz}$ with no LNA Input		53		pA/ $\sqrt{\text{Hz}}$
Output Noise Correlation Factor	Channels 0 - 7 summed together		TBD		dB
Output Compliance Range			2.1 to 3.6		V
Output Impedance	DC to 50 kHz		100k		Ω
Power Consumption	Active Mode (ADC CW/DVGA pin = HI)		1.66	1.70	W
	Power Down		0.05		
Wake-up Time	From Stand-By (From CW DOPPLER to B Mode when AMP CW/DVGA pin is switched from HI to LO). See (Note 17)		13	TBD	μs

LNA Electrical Characteristics

Parameter	Conditions	Min	Typ	Max	Units
Input Voltage Noise	See (Note 2)		0.82		nV/ $\sqrt{\text{Hz}}$
Input Current Noise	$R_S=50\Omega$, $f=1\text{MHz}$, No Active Termination, See (Note 2)		5		pA/ $\sqrt{\text{Hz}}$
Input Capacitance	Each Input to ground		17		pF
Single-Ended Input Swing	1 dB Compression. See (Note 2) & (Note 22)		500		mV p-p
Max Differential Output Swing			3		Vp-p
HD2	$f_{in} = 5\text{MHz}$, -6dBFS out, Minimum DVGA		-55		dBc
HD3	Gain		-52		
Output VCM			1.65		V
LNA Gain	Single-ended In to Differential Out	19	20	21	dB
Power Consumption	Total, 8 channels Active		280		mW
Power Up Time	From Power-Down mode		10		μs

DVGA Electrical Characteristics Unless otherwise noted, specified limits apply for AMP AVCC A = AMP DVDD = 3.3V; "half-step" enabled (SPI™ Register 1Ah[3] = 1), $f_{in} = 5\text{MHz}$. **Boldface** limits apply for $T_A = T_{MIN}$ to T_{MAX} ; All other limits apply for $T_A = +25^\circ\text{C}$.

Parameter	Conditions	Min	Typ	Max	Units
Post Amp Gain	DVGA PA HI = HI	36.0	38.0	40.0	dB
	DVGA PA HI = LO	28.4	31	32.4	
Selectable DVGA Initial Attenuation (See Table 4)	DVGA UP pin = HI CW/DVGA RST pin = HI DVGA INIT MSB pin = LO DVGA INIT LSB pin = LO	36.0	38.0	40.0	dB
	DVGA UP pin = HI CW/DVGA RST pin = HI DVGA INIT MSB pin = LO DVGA INIT LSB pin = HI	34.0	36.0	38.0	
	DVGA UP pin = HI CW/DVGA RST pin = HI DVGA INIT MSB pin = HI DVGA INIT LSB pin = LO	32.0	34.0	36.0	
	DVGA UP pin = HI CW/DVGA RST pin = HI DVGA INIT MSB pin = HI DVGA INIT LSB pin = HI	30.0	32.0	34.0	
	DVGA UP pin = LO CW/DVGA RST pin = HI DVGA INIT MSB pin = X DVGA INIT LSB pin = X	-1.6	0	2.4	
Attenuation Steps	SPI™ Register 1Ah[3] = 0		0.05		dB
	SPI™ Register 1Ah[3] = 1		0.1		
Attenuation error from nominal	See (Note 10)			± 0.15	dB
Attenuator step error from 0.05dB				± 20	mdB
PA Input Noise			3.6		nV/ $\sqrt{\text{Hz}}$
Power-Up Time	From Power-Down mode		0.1		μs

ADC Electrical Characteristics

Unless otherwise noted, specified limits apply for ADC AVDD = ADC DVDD = 1.2V, ADC IO DVDD = 1.2V; $F_{CLK} = 40$ MSPS; Clock duty cycle stabilization enabled; IOR On Mode. AMP CW/DVGA pin = ADC CW/DVGA pin = LO. **Boldface limits** apply for $T_A = T_{MIN}$ to T_{MAX} ; All other limits apply for $T_A = +25^\circ\text{C}$.

Parameter	Conditions	Min	Typ	Max	Units
Resolution	No missing codes. See (Note 11)			12	bits
Sampling Rate	ADC CLK	40		50	MSPS
Conversion Latency	Equalizer On	19	19	19	Samples
Input Range (Differential)	IOR On Mode		3.12		V_{PP}
	IOR Off Mode		4.6		
ADC CLK Duty Cycle		20	50	80	%
RMS Clock Jitter	Generated by PLL. Integrated from 0MHz to BWLoop		300		fsecond
PLL Loop Filter Bandwidth (BWLoop)	Low Bandwidth (ADC CLK = 40MHz)		415		KHz
	High Bandwidth (ADC CLK = 40MHz)		1.5		MHz
Over-sampling Frequency		640		800	MHz
Signal-to-Noise Ratio (SNR)	4.4MHz Input, IOR On Mode		67.6		dBFS
	4.4MHz Input, IOR Off Mode		69.1		
Single-Tone SFDR	4.4MHz Input		76		dBFS
Signal-To-Noise-and-Distortion (SINAD)			67		dBFS
Digital Filter Passband	ADC CLK = 50 MHz, Ripple < +/-0.01dB		22		MHz
	ADC CLK = 40 MHz, Ripple < +/-0.01dB		17.6		
Digital Filter -3 dB Frequency	ADC CLK = 50 MHz		25		MHz
	ADC CLK = 40 MHz		20		
Digital Filter Stop Band Attenuation	$f_{in} \geq 34.5$ MHz		72		dB
Digital filter Group Delay			19		samples
Digital Filter Group Delay Ripple (peak to peak)	$f_{in} < 22$ Mhz with Equalizer On. See (Note 11)			0.05	samples
Instant Overload Recovery (IOR)	≤ 5 dB above Full Scale (dBFS)		1		Sample Clock cycle
Power Consumption (Active)	All 8 channels Active (PD = 0) at 40 MSPS (Group Delay Equalizer OFF)		350		mW
	All 8 channels Active (PD = 0) at 50 MSPS (Group Delay Equalizer OFF)		385		
	All 8 channels Active (PD = 0) at 40MSPS (Group Delay Equalizer ON)		383		
	All 8 channels Active (PD = 0) at 50MSPS (Group Delay Equalizer ON)		435		
Power Consumption (Sleep)	Sleep mode, all 8 channels. See (Note 5)		40		mW
Power Consumption (Power Down)	Power-Down mode, all 8 channels		5		mW
Recovery Time from CW Doppler Mode	ADC CW/DVGA pin switch from Hi to LO		170		μs
Power-up Time	From single channel Power Down (SPI™ register 01h)		6		μs
	From Power Down mode (SPI™ register 00h[0] = HI)		20		ms

Digital Input and Output Characteristics

Unless otherwise noted, specified limits apply ADC AVDD = ADC DVDD = 1.2V; ADC CLK = 40 MHz, ADC IO DVDD = AMP IO DVDD = 1.2V, ADC data out $R_L = 100\Omega$, SPI™ DIO capacitance = 5pF; **Boldface limits** apply for $T_A = T_{MIN}$ to T_{MAX} ; All other limits apply for $T_A = +25^\circ\text{C}$.

Parameter	Conditions	Min	Typ	Max	Units
Single Ended I/O: SPI™ CLK, SPI™ DIO, ADC SPI™ CS, AMP SPI™ CS, DVGA CLK, DVGA UP, DVGA INIT MSB, DVGA INIT LSB, CW/DVGA RST, AMP CW/DVGA, ADC CW/DVGA, LNA PD, DVGA PD, AMP RST, DVGA PA HI:					
Levels & Generic Specifications:					
Logical Input "HI" Voltage		900			mV
Logical Input "LO" Voltage				300	mV
Logical Input Current				±1	µA
SPI™ DIO Logical Output "HI" Voltage	Test run at 1MHz	950	IO DVDD		mV
SPI™ DIO Logical Output "LO" Voltage	Test run at 1MHz		0	250	mV
Timing:					
CW/DVGA RST Setup Time	Falling edge must precede CW CLK+ rising transition by (t_{CWS}). See Figure 10	2			ns
CW/DVGA RST Hold Time	Falling edge must follow CW CLK+ rising transition by (t_{CWH}). See Figure 10		0		ns
CW/DVGA RST Pulse Width	CW Doppler Mode. See Figure 10	2			ns
	B-Mode	200			
CW/DVGA RST Removal time	See (Note 13)	20			ns
DVGA CLK pin Freq				100	MHz
DVGA CLK pin Rise and Fall Time	See (Note 11)			7	ns
DVGA CLK pin Pulse Width		4			ns
AMP SPI™ CS or ADC SPI™ CS Setup Time (t_{SSELS})	See Figure 8	15			ns
AMP SPI™ CS or ADC SPI™ CS Hold Time (t_{SSELH})	See Figure 8	3			ns
AMP SPI™ CS or ADC SPI™ CS HI Time (T_{SSELH})	Read / Write Transactions. See Figure 9			250	ns
SPI™ DIO Setup Time (t_{WS})	Write Transaction. See Figure 8	110	40		ns
SPI™ DIO Hold Time (t_{WH})	Write Transaction. See Figure 8	24	40		ns
SPI™ CLK Write Period (t_{SCLK})	Write Clock Period. See Figure 8	0.2	1		µs
SPI™ Read Propagation Delay (t_{OD})	Read Transaction Propagation Delay. See Figure 9			120	ns
SPI™ Master Hi-Z End (t_{HIZ-E})	Read Transaction End of SPI™ Master HiZ. See Figure 9		100		ns
SPI™ Read Valid Time (t_{VALD})	Read Transaction. See Figure 9		$t_{SCLKRD} - t_{OD}$		ns
SPI™ CLK Read Period (t_{SCLKRD})	Read Clock Period. See Figure 9	0.2			µs
SPI™ CLK Duty Cycle (t_{SCKL} / t_{SCLKH})	See Figure 8	45		55	% of SPI™ CLK Period
SPI™ CLK Rise / Fall Time (t_{SCLKR} / t_{SCLKF})	See Figure 8		50		ns
Differential Input:					
Levels & Generic Specifications:					
CW CLK Level (See Figure 7)	LVDS, Common Voltage. See (Note 11)		1.2		V
	LVPECL, Common Voltage. See (Note 11)		2.0		
	LVDS, Differential Voltage. See (Note 11)	240	400		mV
	LVPECL, Differential Voltage. See (Note 11)	600	800		

Parameter	Conditions	Min	Typ	Max	Units
CW CLK Input Impedance	Differential		10		k Ω
ADC CLK Level	Common Mode (AC Coupled within LM96511). See (Note 16)		0.4 to ADC AVDD		V
	Differential Mode Drive (peak-to-peak) or Single Ended. See (Note 16)	200	400	ADC AVDD	mV
Differential Output:					
Levels & Generic Specifications:					
Output Differential Voltage (V_{OD})	ADC IO DVDD = 1.2V Reduced CM LVDS, RL = 100 Ω , OCM = 0. See (Note 11)	318	370	428	mV
	ADC IO DVDD = 1.8V LVDS, RL = 100 Ω , OCM= 1. See (Note 11)	280	350	417	
	ADC IO DVDD = 1.2V SLVS, RL = 100 Ω . See (Note 11)	262	330	393	
Output Common Mode Voltage (V_{OCM})	ADC IO DVDD = 1.2V Reduced CM LVDS, RL = 100 Ω , OCM = 0. See (Note 11)	895	945	1000	mV
	ADC IO DVDD = 1.8V LVDS, RL = 100 Ω , OCM= 1. See (Note 11)	1200	1265	1340	
	ADC IO DVDD = 1.2V SLVS, RL = 100 Ω . See (Note 11)	185	225	270	
Output Short Circuit Current (I_{OS})	Shorted to GND.		4	4.5	mA
High Impedance Output Current (I_{OZ})	Tri-stated (opened)	-10	± 1	10	μ A
Timing:					
ADC BCLK (Bit Clock) Period (t_{BCLK})	ADC CLK= 40 MHz. See Figure 5		4.16		ns
Bit Clock (ADC BCLK) Jitter (RMS)	See (Note 11)			2	ps
ADC WCLK (Word Clock) Period (t_{WCLK})	ADC CLK= 40 MHz. See Figure 5		25		ns
Output Data Edge to Output Clock Edge Setup Time (t_s)	ADC CLK= 40 MHz. See Figure 5	480	900		ps
Output Data Edge to Output Clock Edge Hold Time (t_H)	ADC CLK= 40 MHz. See Figure 5	770	1150		ps
Output Data Valid Window (t_{DV})	ADC CLK= 40 MHz. See (Note 11) & Figure 5	1410	1820		ps
Rise/ Fall Time	ADC CLK= 50 MHz		320		ps
Data Edge to Word Edge Skew (t_{DWS})	ADC CLK= 50 MHz. See Figure 5	-720	-295	220	ps
ADC Input Clock to Word Clock Delay (t_{prop})	ADC CLK = 40 MHz. Upon applying RST signal or a proper power reset.		5.4		ns
	ADC CLK = 50MHz. Upon applying RST signal or a proper power reset.		5.1		ns

Note 1: Absolute maximum ratings are those values beyond which the safety of the device cannot be guaranteed. They are not meant to imply that the device should be operated at these limits. Operating Ratings indicate conditions for which the device is guaranteed to be functional, but do not guarantee specific performance limits. Guaranteed specifications and test conditions are specified in the Electrical Characteristics sections below. Operations of the device beyond the Operating Ratings is not recommended as it may degrade the lifetime of the device. All voltages are measured with respect to GND = AGND = DNGD = 0V, unless otherwise specified.

Note 2: The LNA non-inverting input is always driven single-ended. The inverting input is always AC grounded. See the Application Information section for typical connection diagrams in Figure 12.

Note 3: Min and Max limits are 100% production tested at 25°C. Limits over the operating temperature range are guaranteed through correlation using Statistical Quality Control (SQC) methods. Limits are used to calculate National's Average Outgoing Quality Level (AOQL).

Note 4: Typical values represent the most likely parametric norm as determined at the time of characterization. Actual typical values may vary over time and will also depend on the application and configuration. The typical values are not tested and are not guaranteed on shipped production material.

Note 5: Sleep mode keeps the PLL, Reference and Bias networks active to allow fast recovery and interleaved imaging modes.

Note 6: Per 1 Hz BW, offset 1 kHz from a 5 MHz, FS input. Output Phase noise, expressed in - dBc/Hz, follows both RF input and CW CLK phase noise. To meet the demodulated Output specification, integrated phase noise of both the RF Input signal and CW CLK must be better than -160 dBc/Hz at 1 kHz offset.

Note 7: Within one channel

Note 8: Channel-to-Channel

Note 9: One channel with active input and the worst of the other 7 channels measured.

Note 10: "Nominal" attenuation defined as straight line connecting minimum attenuation (0dB) to maximum attenuation (38dB).

Note 11: This parameter is guaranteed by design and/or characterization and is not tested in production.

Note 12: Guaranteed by characterization for all phases.

Note 13: "Removal time" refers to the time CW/DVGA RST must be low prior to the rising edge of DVGA CLK.

Note 14: Intermodulation Distortion with unequal tones performed using [Figure 3](#) ($\Delta P = 25$ dB).

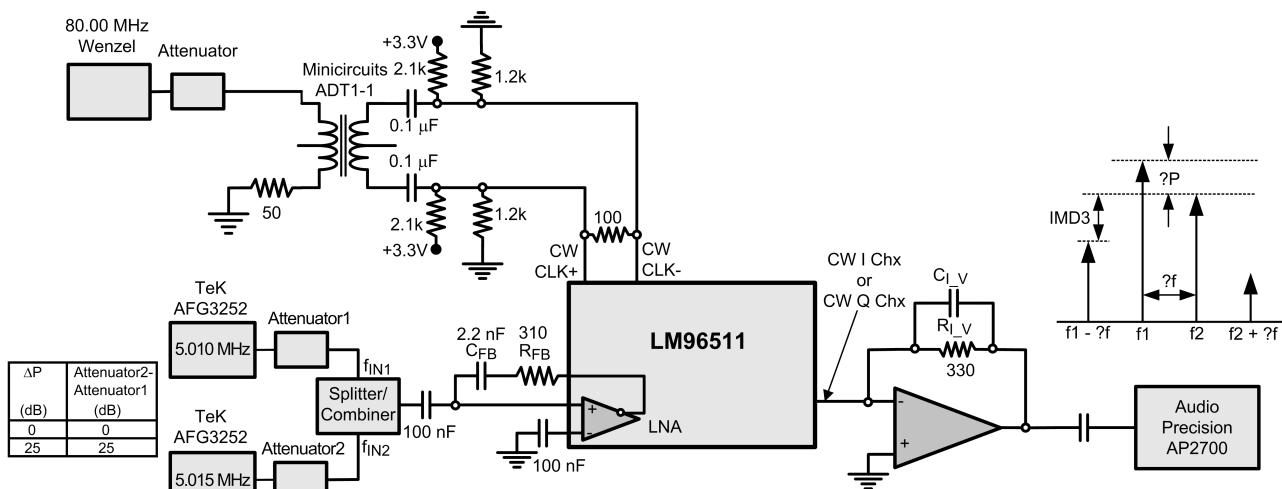

30087012

FIGURE 3. Intermodulation Distortion Measurement with Unequal Tones

Note 15: SPI™ master has to release the bus by initiating Hi-Z state on or before LM96511 SDIO t_{OD} time.

Note 16: ADC CLK input(s) minimum swing should never extend more negative than ground because of ESD protection diode(s) to ground.

Note 17: "Wake up" time defined as the time it takes the output (or its digital representation) to reach within 10% of expected.

Note 18: Maximum expected full scale amplitude loss due to DC offset (minimum DVGA attenuation):

$$= 20 \times \log \left(\frac{2^{12} - |\text{Offset (LSB)}|}{2^{12}} \right)$$

For Further information, refer to the "Offset Soft-Trim" section.

Note 19: Human Body Model, applicable std. MIL-STD-883, Method 3015.7. Machine Model, applicable std. JESD22-A115-A (ESD MM std. of JEDEC). Field-Induced Charge-Device Model, applicable std. JESD22-C101-C (ESD FICDM std. of JEDEC).

Note 20: Propagation Delay, t_{OD} , tested with SPI™ DIO capacitance ≈ 100 pF and measured to 10% change in level.

Note 21: CW Doppler Phase Noise measurement and calculation:

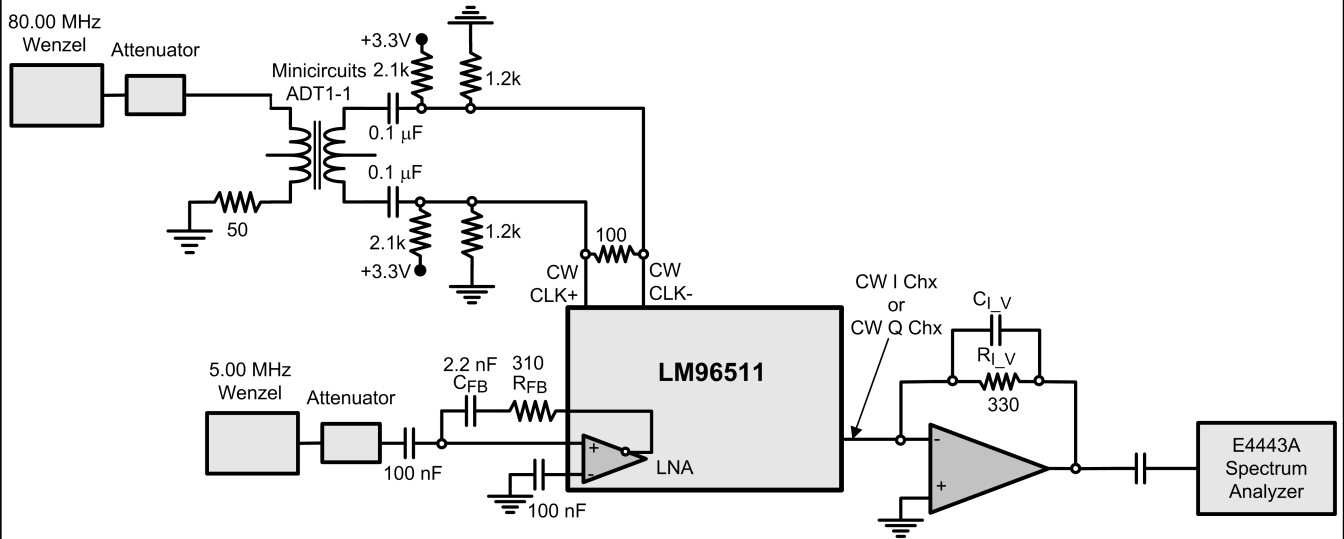

- (1) Noise (dBc/√Hz) = E4443A Noise Marker Reading (dBm/Hz)* - Full Scale RMS Output (dBm)
 * Reading RSS corrected for CW Doppler Off
- (2) Full Scale RMS Output (dBm) = $20 \times \log \left(\frac{\text{LNA Input (V}_{PP}) \times \text{CW Doppler Gain} \times R_{I_V}}{2\sqrt{2}} \right) + 13.0$
 CW Doppler Gain = 25.8 mA/V
 R_{I_V} = 330Ω
- (3) Full Scale RMS Output (dBm) = 20 x log (LNA Input (V_{PP})) + 22.6

30087090

FIGURE 4. CW Doppler Phase Noise Measurement

Note 22: Please take note of the LNA Input Amplitude Range information described in the [LNA INPUT AMPLITUDE RANGE](#) Section

Timing Diagrams

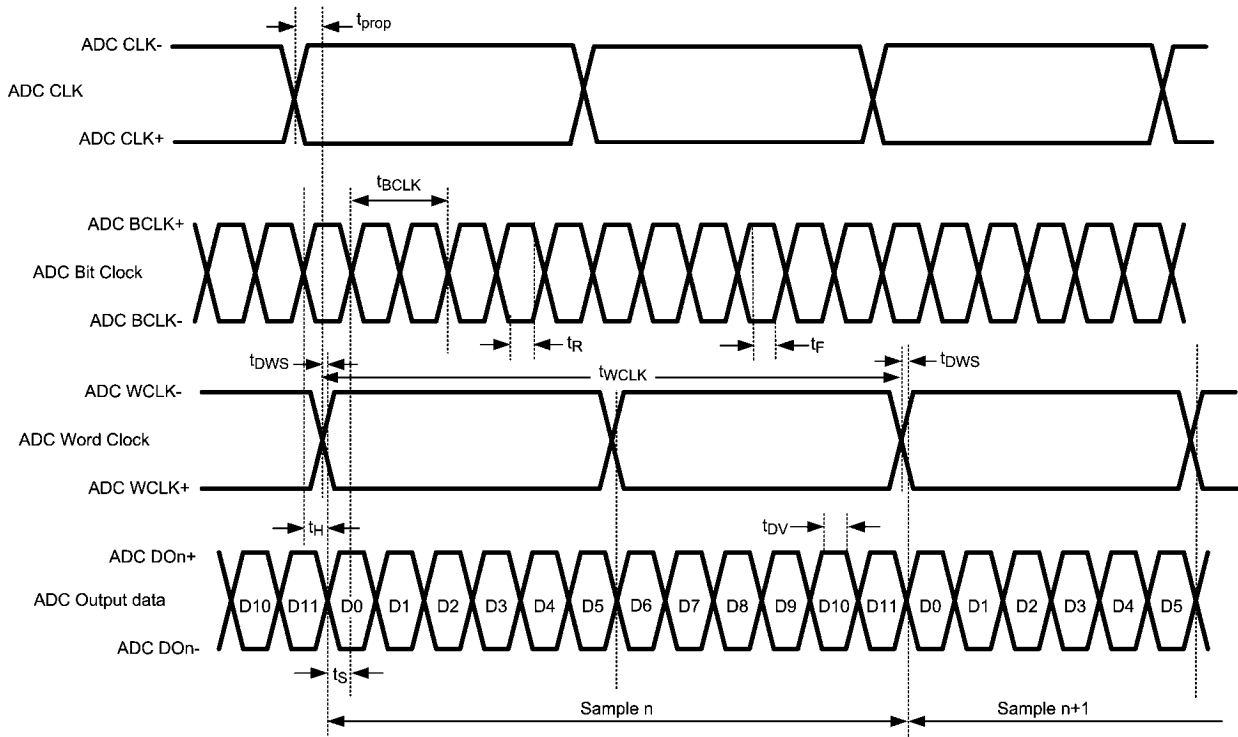

30087013

FIGURE 5. B-Mode ADC Data Output Timing

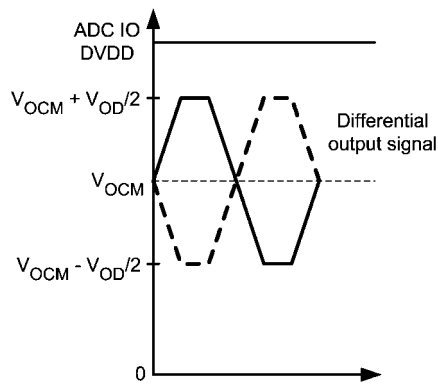

30087014

FIGURE 6. B-Mode ADC Data Output Level Definitions

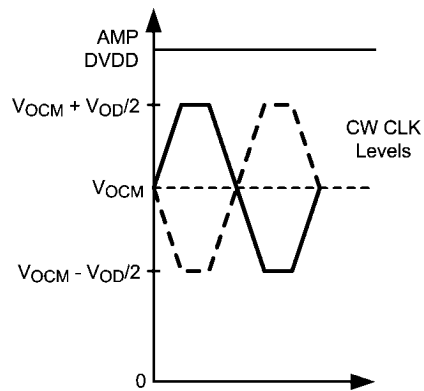

30087089

FIGURE 7. CW CLK Level Definitions

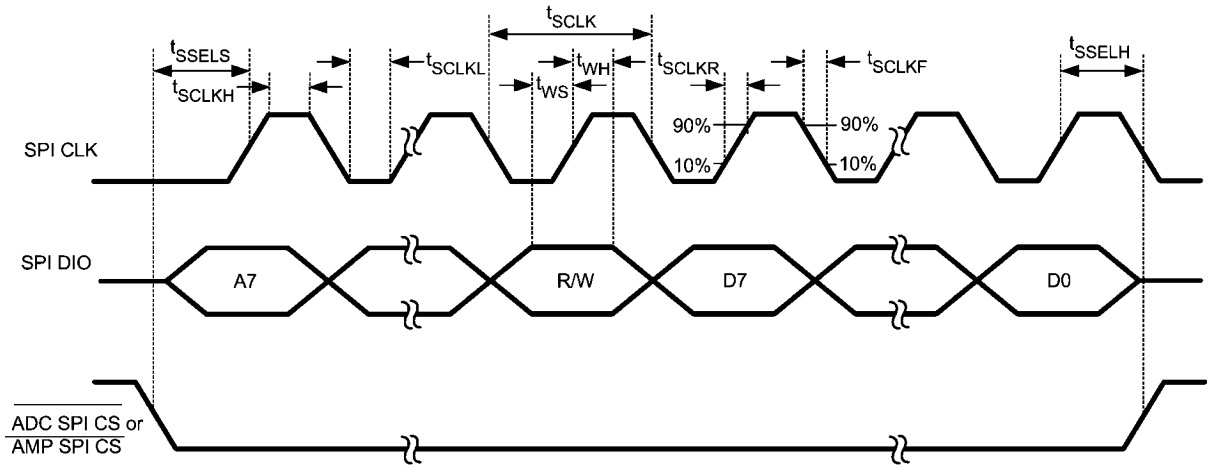

30087015

FIGURE 8. SPI™ Write Timing

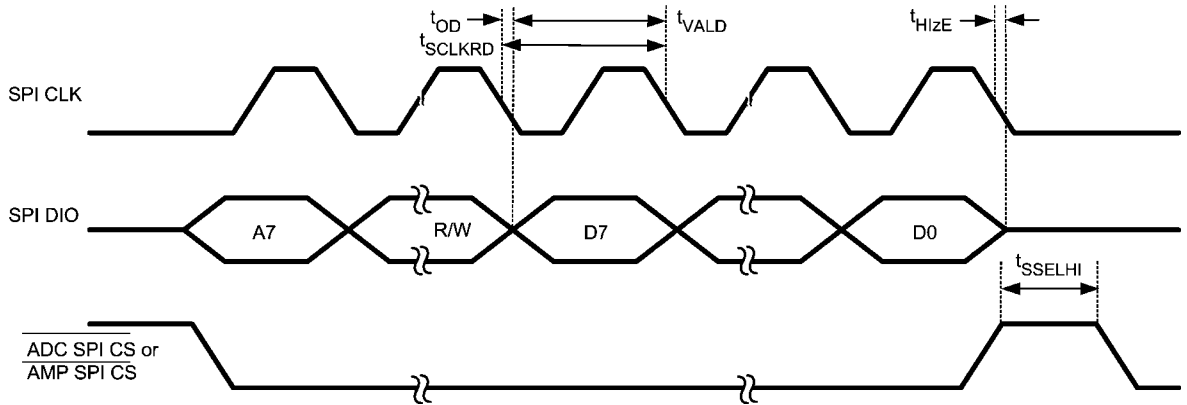

30087016

FIGURE 9. SPI™ Read Timing

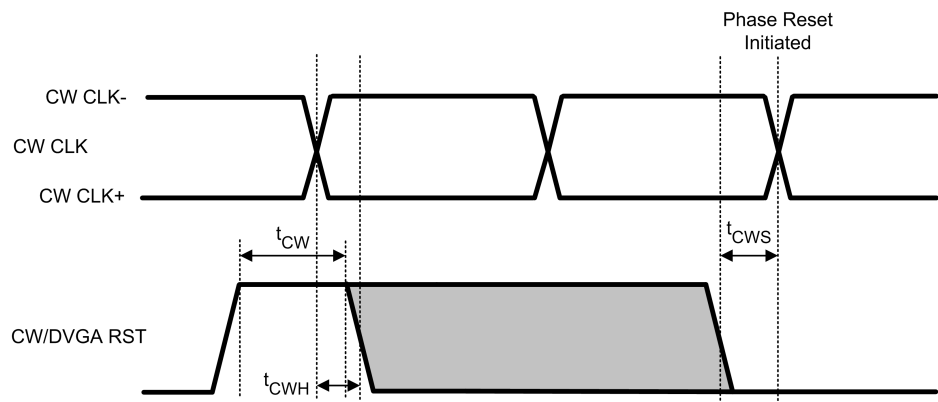

30087017

FIGURE 10. CW/DVGA RST Timing (CW Doppler Mode)

Typical Performance Characteristics

Unless otherwise noted, AMP AVCC A = AMP DVDD = 3.3V, CW AVCC = 5V; ADC AVDD = ADC DVDD = 1.2V, ADC IO DVDD = AMP IO DVDD = 1.2V, Full Scale RF Input at 5 MHz; CW CLK = 80 MHz;; FCLK = 40 MSPS ,TA = +25°C.

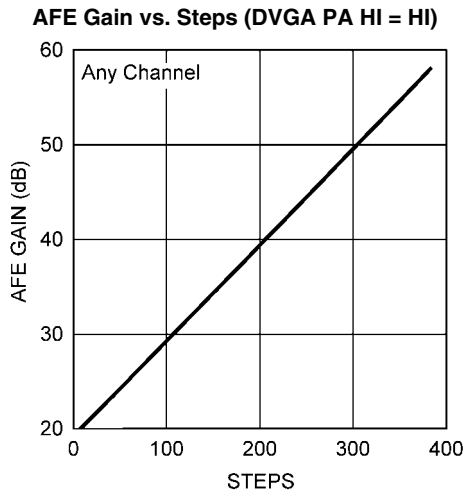

30087024

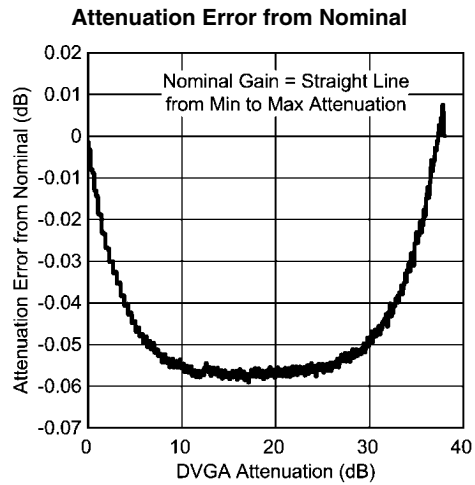

30087063

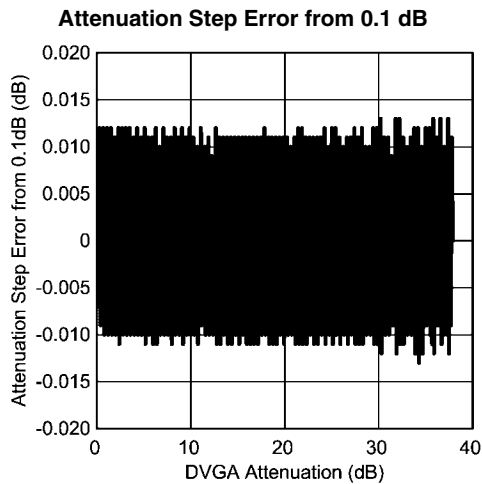

30087064

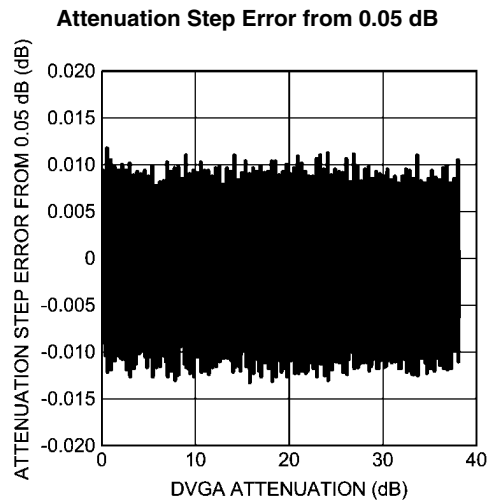

30087088

Gain Variation from Nominal vs Supply Voltage

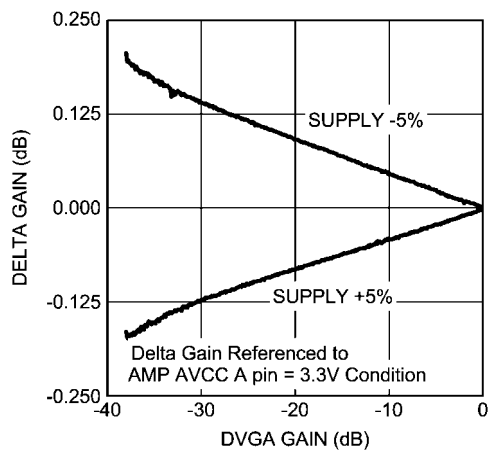

30087027

Gain Variation from Nominal vs Temperature

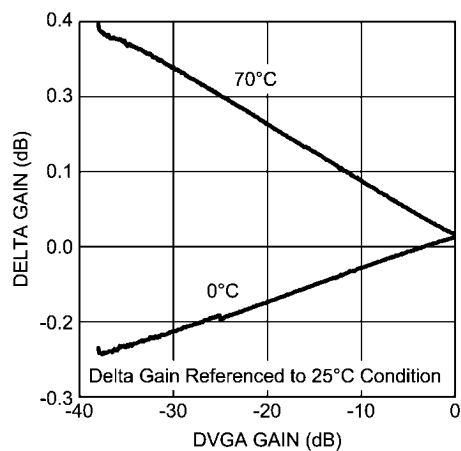

30087026

LNA S11 vs. Frequency

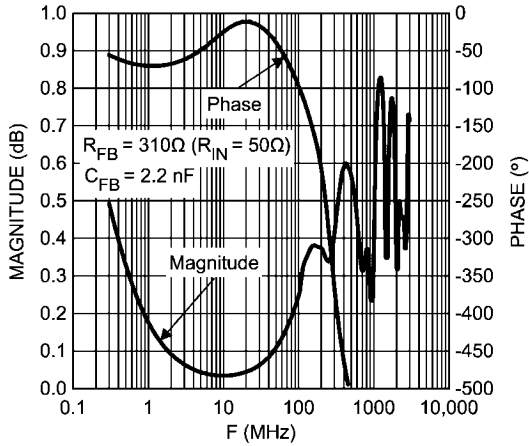

30087067

AFE Offset Distribution IOR On Mode, Minimum DVGA attenuation, DVGA PA HI pin = LO

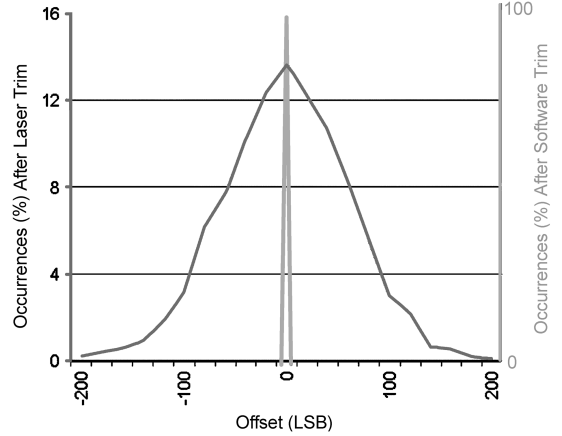

30087092

HD vs. LNA Input Swing (PA HI pin = LO)

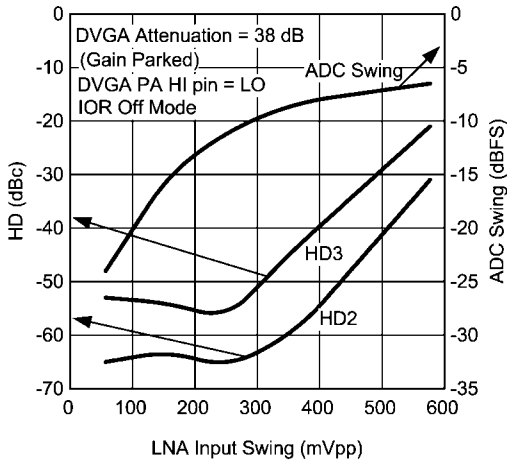

30087091

HD vs. LNA Input Swing (PA HI pin = HI)

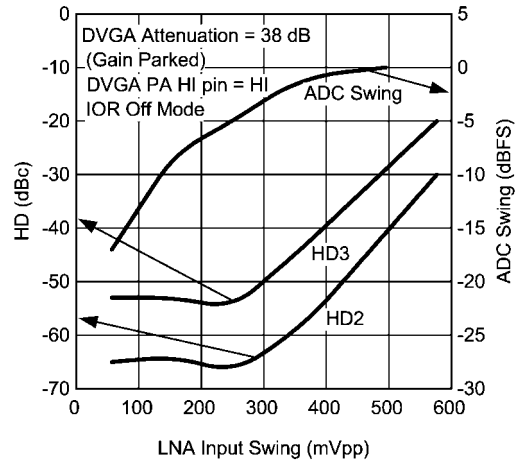

30087093

RTI Noise vs. Frequency (DVGA Attenuation = 0dB)

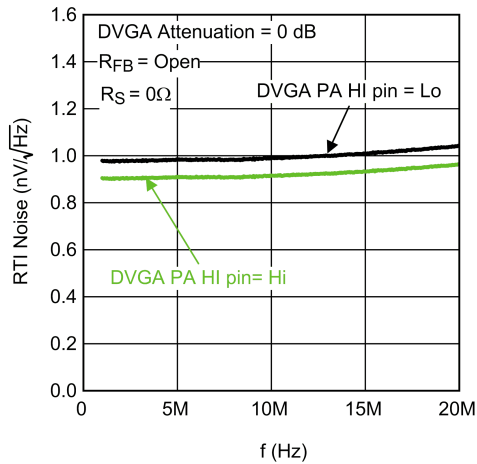

30087022

RTI Noise vs. Frequency (DVGA Attenuation = 32dB)

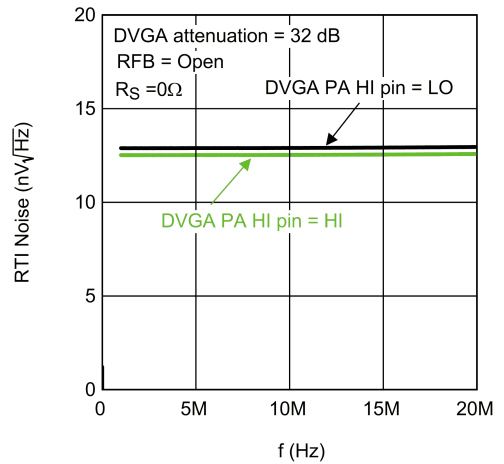

30087082

**Far-Field Overload Recovery
@ Post Amp Output (No User Access)**

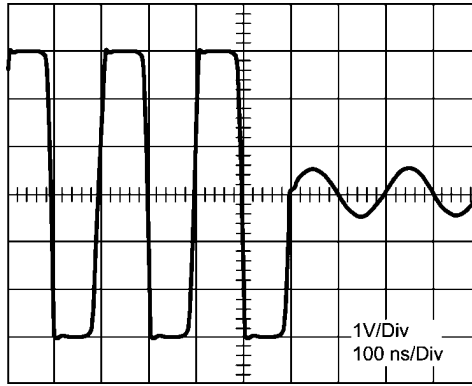

30087073

AFE (B-Mode) Overload Recovery

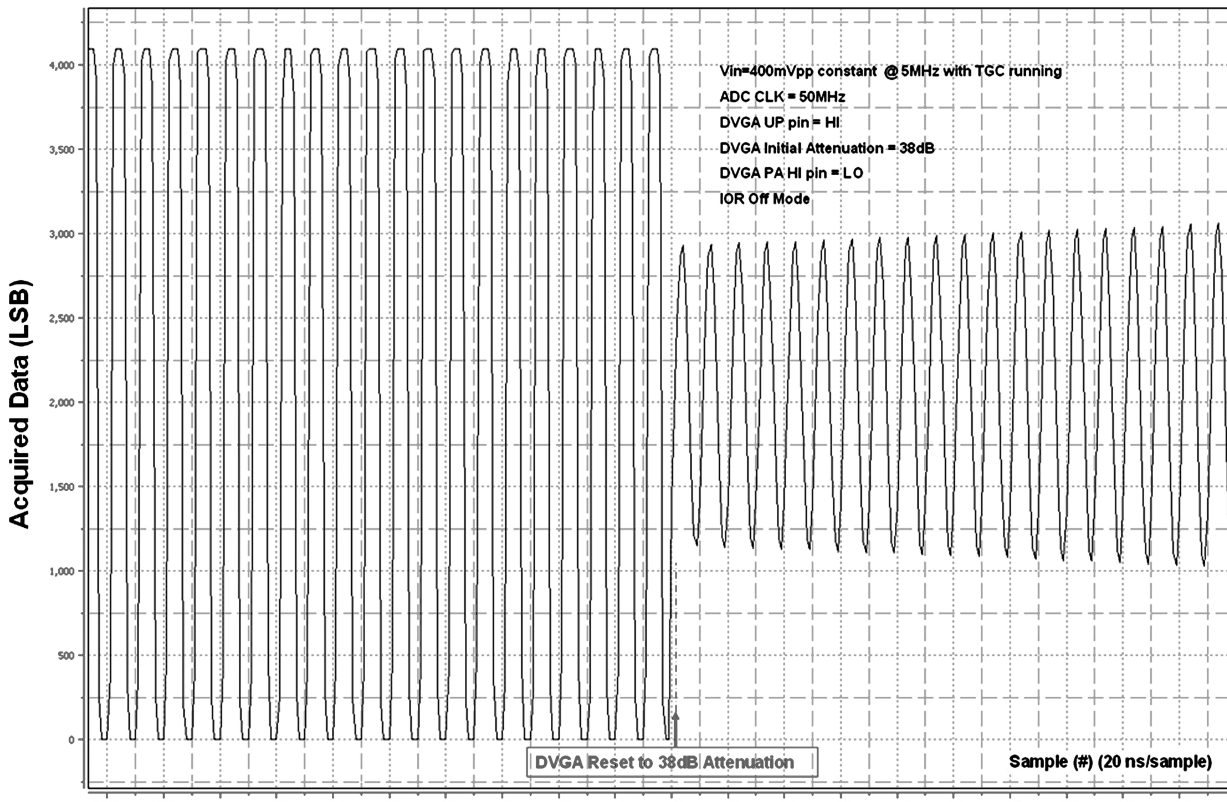

30087094

**Spectral Response @ $f_{IN}=10$ MHz,
ADC CLK = 400 mHz, IOR On**

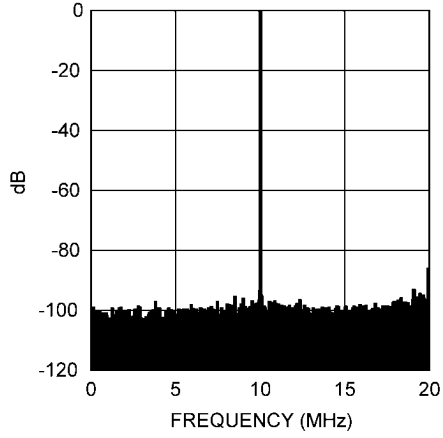

30087077

**Close-In Spectral Response @ $f_{IN}=1.9$ MHz,
TGC Running, Cosine 6 Term Window**

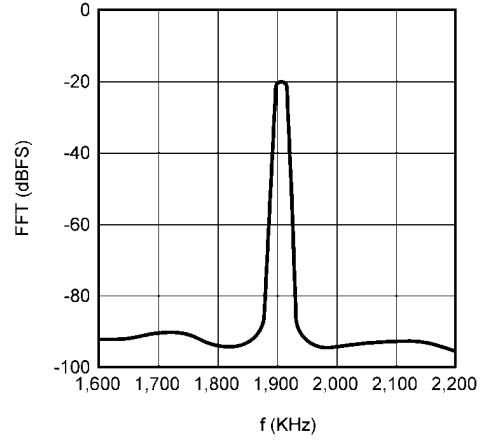

30087095

ADC INL

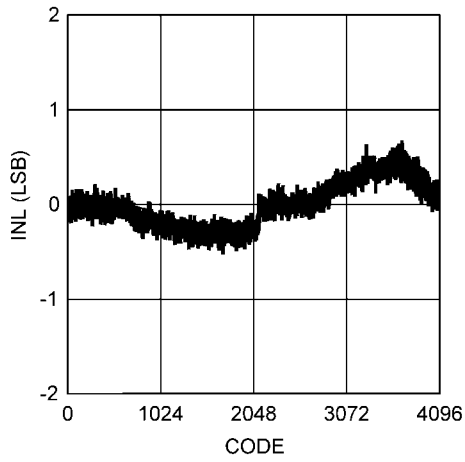

30087076

ADC DNL

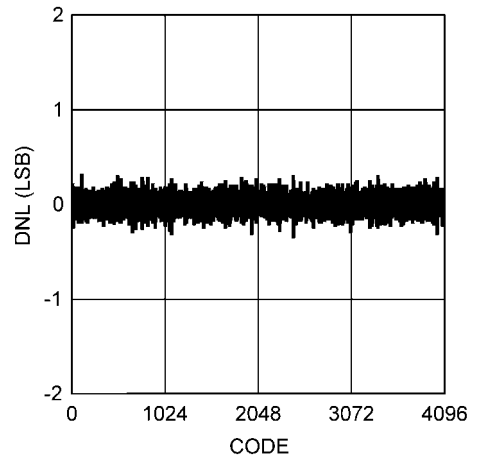

30087075

CW Doppler Plots

CW Doppler IMD3, Unequal Tones
 See Electrical Characteristics (*Note 13*),
 10kHz & 15kHz Offset,
 25 dB Separation

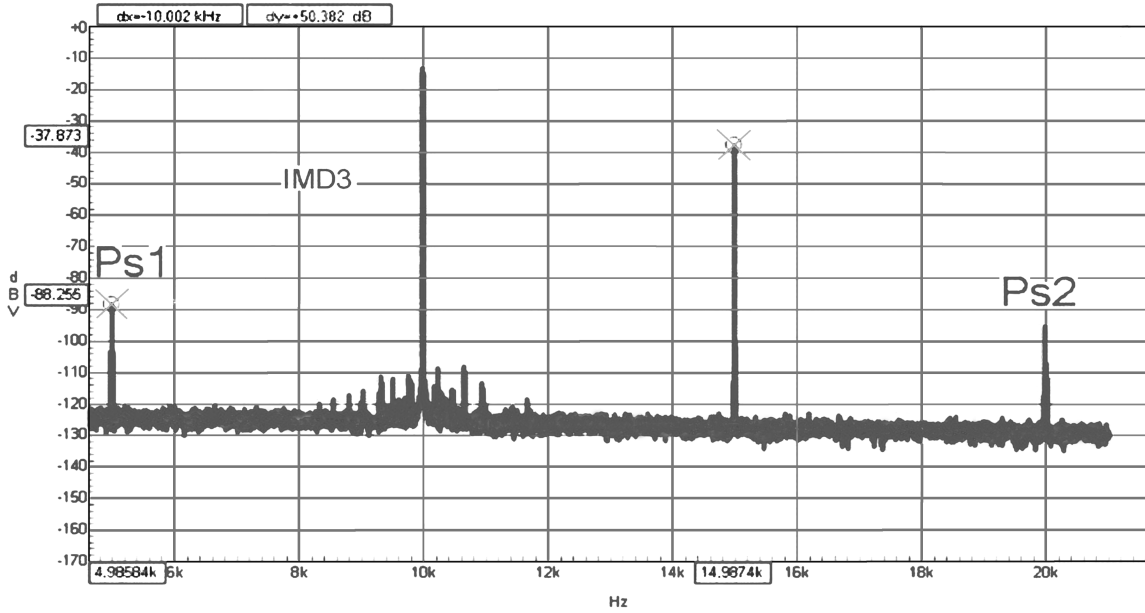

30087030

CW Doppler Output Noise (CWDIFF CLK = 80.0MHz)

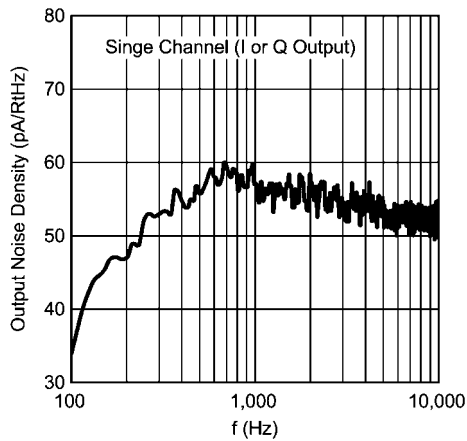

30087080

CW Doppler Phase Noise, See Electrical Characteristics (*Note 6*)

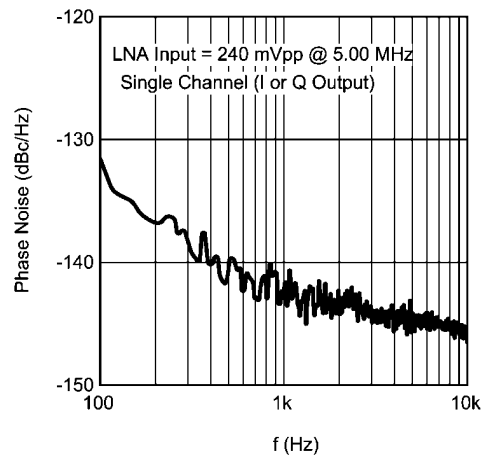

30087081

I-Q Quadrature Phase Error (Within Channel)

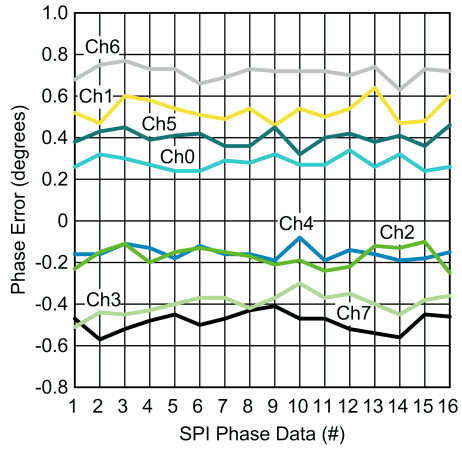

30087068

I-Q Output Amplitude Match (Within Channel)

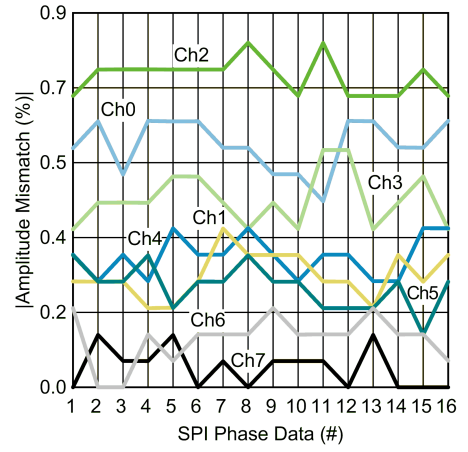

30087069

Overview

The LM96511 is an eight-channel, fully integrated entire sub-system intended for ultrasound receive applications. LM96511 consolidates many receiver functions currently residing in multiple IC's, thereby achieving lower cost, higher board density, higher performance, lower system integration cost, and lower power consumption. The LM96511 has two distinct signal paths: one for B-mode (Brightness) and the other for CW-mode (CW Doppler). The LM96511 consists of the following blocks / functions for each of its 8 channels:

1. Low-Noise Amplifier (LNA) with programmable input impedance for improved ultrasound probe matching characteristics

2. Digital Variable Gain Amplifier (DVGA) with capability to increase or decrease gain (linear in dB) using digital input for rate of change control
3. 12-Bit ADC with on board PLL for superior jitter reduction
4. CW Doppler output (I and Q) with 16 user selectable phase rotation
5. SPI™ compatible interface for user programming and control

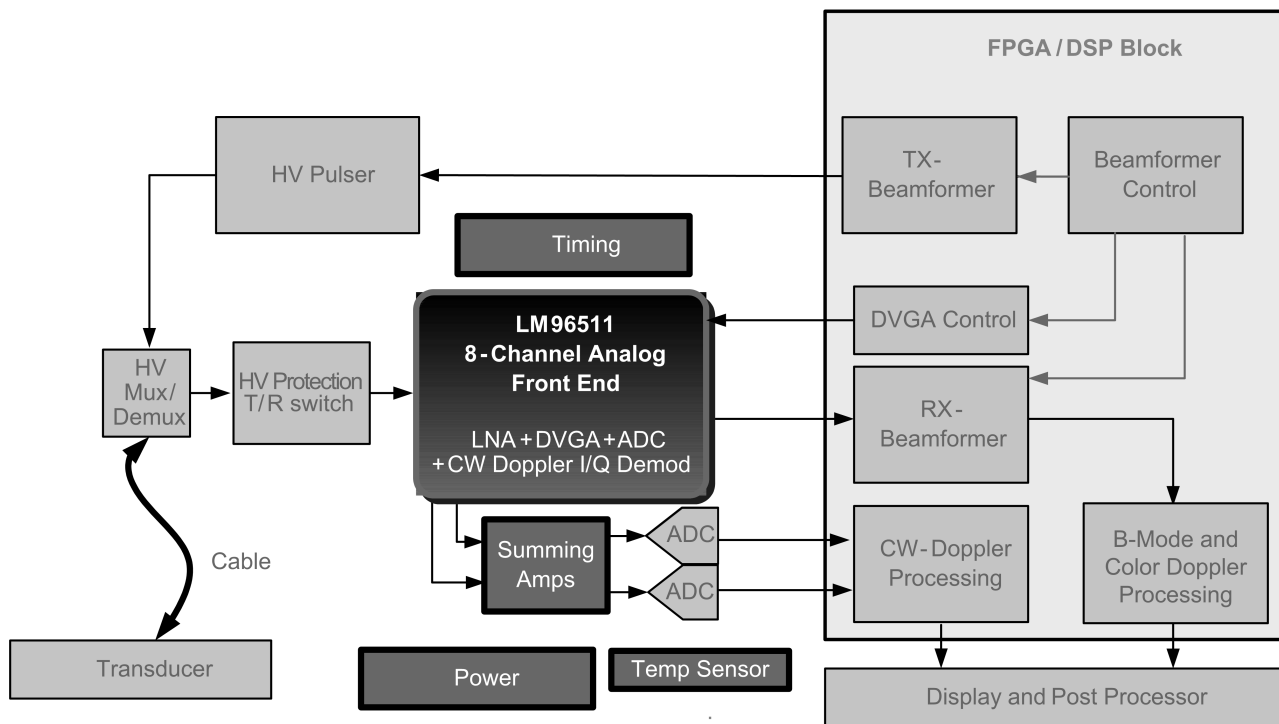

30087031

FIGURE 11. Ultra-Sound System Block Diagram

LNA INPUT AMPLITUDE RANGE

The input amplitude range of the LM96511's Low Noise Amplifier is well suited for ultrasound applications in both CW and B-Mode operation. However, T/R switch leakage and strong echoes from near-field or acoustically dense material is unavoidable. Because of such large transient signal amplitudes and increasing DVGA gain during TGC, overload at the LNA input impairs signal integrity in ultrasound applications. Thus, it is very important to prevent the LM96511 inputs from being overloaded by: (1) limiting the input signal amplitude (see further explanation in the next section); (2) gating the transmit signal path before it reaches the T/R switch; and (3) clamping the input signal with a pair of back-to-back signal diodes as additional protection against overload at the LNA input.

Furthermore, in B-Mode TGC operation, when the LNA functions in series with the DVGA and Post-Amplifier, the maximum input signal swing is subject to the LNA's output slew rate limitation. Because the LNA has a maximum differential output slew rate of 100V/μs, or 50V/μs at its inverting output, the input signal should be adjusted such that the inverting

output of the LNA does not exceed this 50V/μs limit. In addition to limiting the input signal slew rate, to avoid further overload effects induced by surges in input bias current associated with the maximum slew rate limitation, the signal swing at the LNA input should be limited to 200mV_{PP} for optimal performance across typical signal frequencies above 5MHz. Ultimately, it is most important to ensure that the input signal is within the LNA's slew rate limitation. Thus, as shown in and explained further in the next section, the input circuit to the LM96511 should have the current source for the T/R switch diode bridge carefully selected to limit the input current to the LNA (~1mA) and include a capacitor (~100pF) and resistor (~100Ω) to ground.

TYPICAL INPUT CONFIGURATION

The schematic in *Figure 12* shows a typical B-Mode input configuration circuit for the LM96511. The input is typically AC coupled through a T/R switch diode bridge configuration which blocks the transmit (Tx) high voltage pulses from the receive (Rx) low voltage inputs.

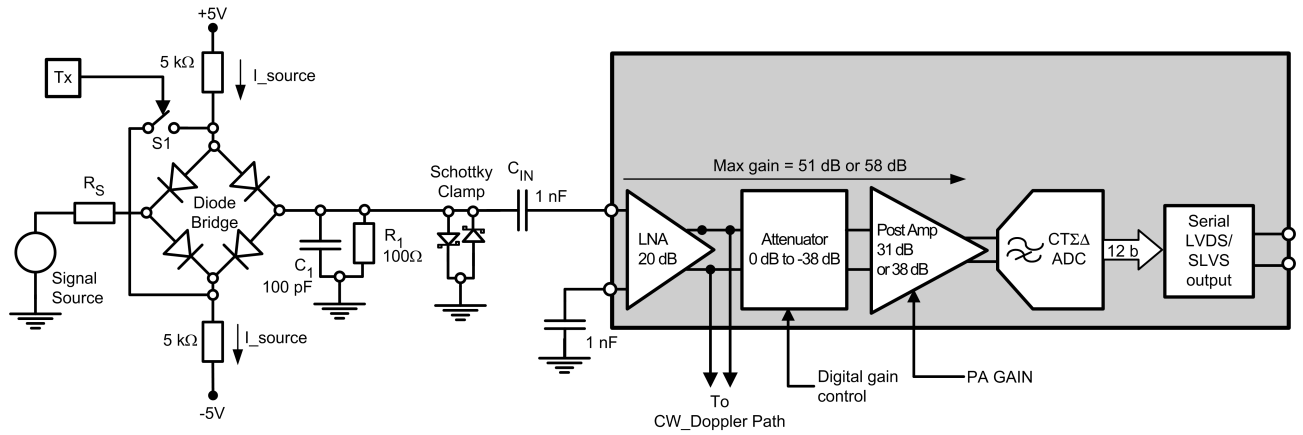

30087032

FIGURE 12. Signal Path (B-Mode) Single Channel Including Input Clamp and Diode Bridge

It is recommended to use National Semiconductor's LM96530 T/R switch with the LM96511 AFE for optimal operation and performance. Alternatively, the discrete 4-diode bridge T/R switch shown in [Figure 12](#) may be used. In such designs, diode characteristics are not ideal, and thus the LM96511 inputs should be protected from the resulting leakage transients, as well as strong reflections. Thus, the transmit signal path should be gated off with switch S1.

During Ultrasound Rx, switch S1 is open and, with no input signal, "I_source" flowing from the top current source, through the 4 diodes, to the bottom current source. The Input signal crosses the diode bridge to the LM96511 input as long as the current through C_{IN} is less than "I_source" (~1mA). Larger input signal amplitudes which require excess C_{IN} current beyond I_source's value will thus be limited by the diode bridge action. During the Tx cycle, switch S1 is shorted so that the Diode Bridge is current starved and any leakage from the T/R switch (not shown) will be strongly attenuated. This ensures effective isolation for maximum protection in the presence of any Tx leakage.

In addition to gating the transmit path with switch S1, capacitor C1 and termination resistor R1 must be included to improve overload recovery time and reduce reflection. C1 acts as a filter to suppress high voltage transient spikes, while R1 acts to divide the signal amplitude down to a favorable level for the LM96511 input, e.g., 200mV_{PP}. This provides adequate protection for the LNA input. C1 (~100pF) also acts to band-limit the input signal to ensure that it is within the LNA's slew rate limitation. Although R1 may increase the noise figure and the input impedance seen by the ultrasound transducer, it still provides good harmonic distortion and low offset. Finally, the Schottky clamp diodes provide an additional level of overload protection where the LM96511 input swing is limited to $\sim \pm 0.35V$ regardless of the LM96511's input impedance.

PROGRAMMABLE INPUT IMPEDANCE & LNA GAIN SELECTION

The LM96511 input termination can be configured in either of two ways:

1. Standard Termination is illustrated in [Figure 13](#), where the receive (Rx) probe (through the T/R switch) is terminated with R_T for proper cable termination, and AC coupled to the LNA's non-inverting input. The inverting input is returned to ground through a capacitor.

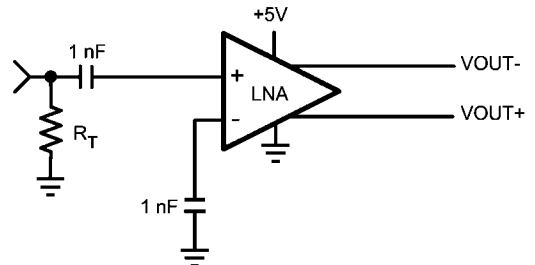

30087033

FIGURE 13. Standard Input Termination

2. Active feedback termination is illustrated in [Figure 14](#), where no termination resistor is used and feedback ($R_{FB} + C_{FB}$) sets the effective input impedance to provide proper cable termination. This termination scheme is employed for improved harmonic distortion and noise performance. With no physical termination resistor, there is no resistor thermal noise degradation of the LNA noise, and thus increased SNR compared to standard termination.

However, as with any amplifier with active feedback termination, abrupt increases in input amplitude may diminish the active termination and may even result in total loss of termination, which will then further overload the LM96511 inputs. It is important to be mindful that with active feedback termination, the LNA is: (1) even more susceptible to overload effects associated with the maximum slew rate limitation mentioned above; and (2) subject to gain reduction at higher output amplitudes. Thus, in achieving better harmonic distortion and noise performance, active feedback termination may be employed, but as long as the input signal is limited to an

amplitude of 200mV_{PP} and slew-rate limited such that the LNA inverting output slew rate is less than $50\text{V}/\mu\text{s}$.

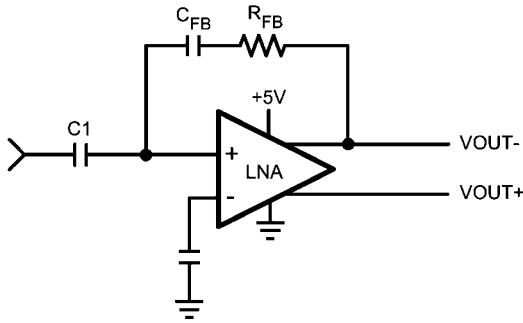

30087034

FIGURE 14. Active Termination Schematic

Active impedance termination is achieved through an external shunt feedback resistor from LNA IN+ to LNA OUT-. The input resistance R_{IN} is given by the equation below, where A is the LNA single-ended gain ($=10\text{V}/\text{V} \div 2 = 5\text{V}/\text{V}$) and $5\text{k}\Omega$ is the un-terminated input impedance of the LM96511 LNA. C_{FB} is required in series with R_{FB} , since the DC levels at LNA IN+ and LNA OUT- are unequal.

$$R_{IN} = \frac{R_{FB}}{1 + A} \parallel 5\text{ k}\Omega$$

30087035

$R_{IN} (\Omega)$	$R_{FB} (\Omega)$
50	301
7	453
100	619
200	1.24k
1k	7.5k
3k	45.3k

OFFSET SOFT-TRIM

To minimize offset, the LM96511 is laser trimmed during manufacturing. To improve accuracy and to allow periodic calibration, if needed, the LM96511’s LNA and Post-Amplifier (PA) include provisions for offset trim using the SPI™ compatible interface after chip power-up (volatile).

In B-mode, LNA offset trim improves gain-dependant offset shift, while PA offset trim reduces fixed offset to maximize the LM96511 ADC’s Full-Scale swing for maximum dynamic range. SPI™ offset trim should be performed with a software algorithm (Soft-Trim) that looks at the ADC code, at various DVGA attenuation settings, and then invokes a binary search for the best value that centers the ADC code. A couple of it-

erations are usually adequate to “zero-in” on the best Soft-Trim setting for each channel. National Semiconductor provides such software algorithms to its customers for use “as-is” or for modification to meet individual requirements.

Figure 15 shows the LM96511 B-mode offset, measured through the ADC. As can be seen, Soft-trim allows extremely accurate offset adjustment (typically within 1LSB) and allows significant tightening of the distribution.

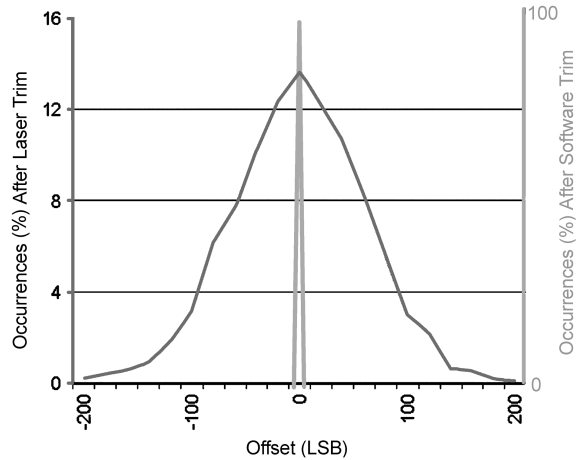

30087092

FIGURE 15. Offset Distribution Histogram including Soft-Trim Improvement

Maximum expected full scale amplitude loss due to DC offset is:

$$= 20 \times \log \left(\frac{2^{12} - |\text{Offset (LSB)}|}{2^{12}} \right)$$

DYNAMIC RANGE

Figure 15 shows the LM96511 B-mode TGC in action. In this diagram, a 5MHz ultrasound signal enters the LNA with 350mV_{PP} single ended Near Field (NF) amplitude and the signal path headroom runs into clipping. 3.5V_{PP} differential NF amplitude appears at the LNA output (Differential gain = 20dB) where the DVGA TGC will equalize the signal so that the ADC FS range of 3.12V_{PP} (with IOR On or 4.4V_{PP} with IOR off) can be transversed to maximize the data acquisition resolution. Note that the LM96511’s B-mode ADC operates off a 1.2V supply and yet can accommodate 3.12V_{PP_FS} with IOR on or 4.4V_{PP_FS} with IOR off. This is because of the coupling resistor ladder built into the ADC in spite of ADC input noise level performance which does not impact ENOB.

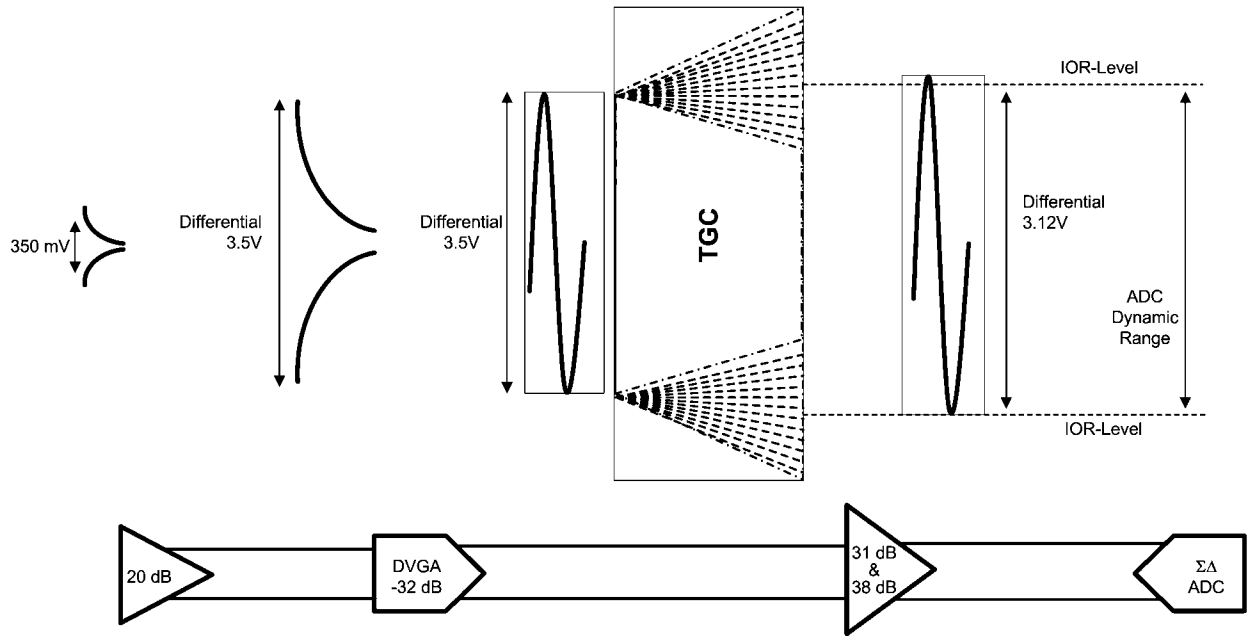

FIGURE 16. LM96511 in Typical TGC Operation at 5MHz

DVGA OPERATION

The LM96511 features a linear-in-dB, digital variable gain amplifier which consists of a digitally variable attenuator and post amplifier. The attenuator has a variable range of 0 to -38dB (or -36, -34, or -32dB depending on settings) in increments of either 0.05dB or 0.1dB per LSB step (depending on the "Half Step" mode setting). The variable gain operation is essentially achieved with a "Clock and Reset" scheme. There are three digital control signals for the attenuator: DVGA CLK, CW/DVGA RST, and DVGA UP.

The heart of the variable gain control lies in the DVGA CLK and CW/DVGA RST logic input signals, as illustrated in [Figure 17](#). The positive edge of every CLK pulse will increment or decrement each gain step for as long as the CW/DVGA RST logic pulse is LOW. For a periodic gain ramp-up sequence, the negative edge of every CW/DVGA RST pulse begins a

ramp upwards, and the positive edge of every RESET pulse ends the ramp, resetting the gain back to its DVGA Initial Attenuation. The number of DVGA CLK pulses during each LOW interval of the CW/DVGA RST pulse, determines the duration of the gain ramp, while the frequency of the DVGA CLK pulses determines the slope of the gain ramp.

The DVGA UP input determines whether gain is incremented or decremented. Depending on the logic level of this input, the DVGA can begin at the bottom of the gain ramp (maximum attenuation setting) and proceed to ramp up, or at the top of the gain ramp (minimum attenuation setting) and proceed to ramp down. [Figure 18](#) illustrates how this logic level can also be dynamically changed midway through a ramp up or ramp down operation, which can allow the sonographer to flatten the image's grey background or to reduce the level of a bright reflector.

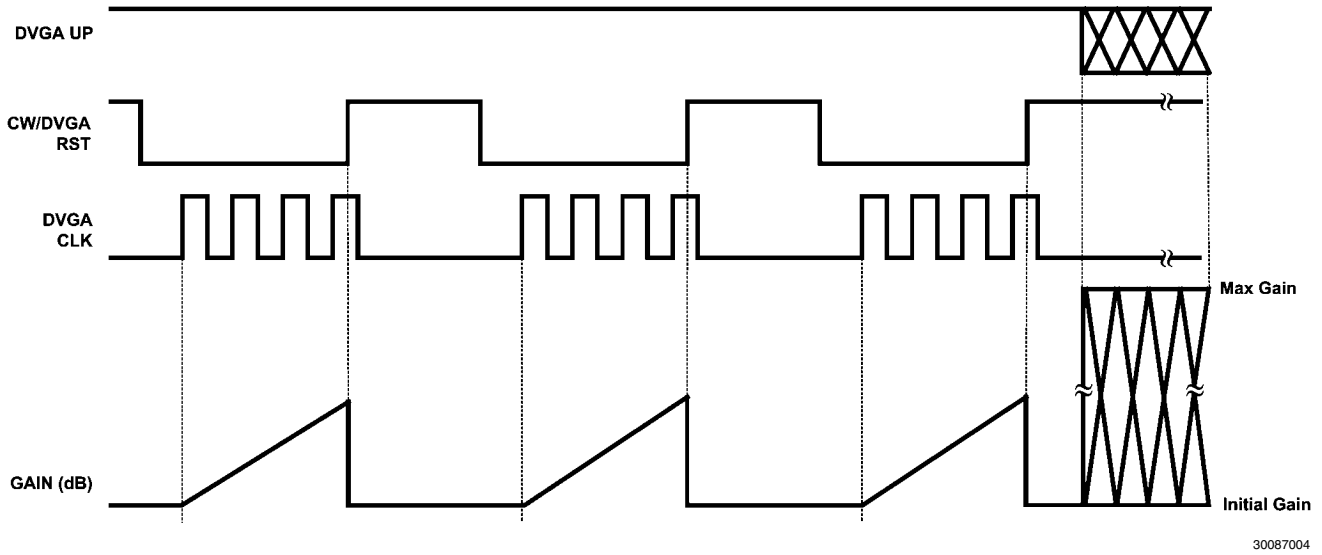

FIGURE 17. Periodic TGC Ramp: Example 1 (Half-Step Disable bit = 1)

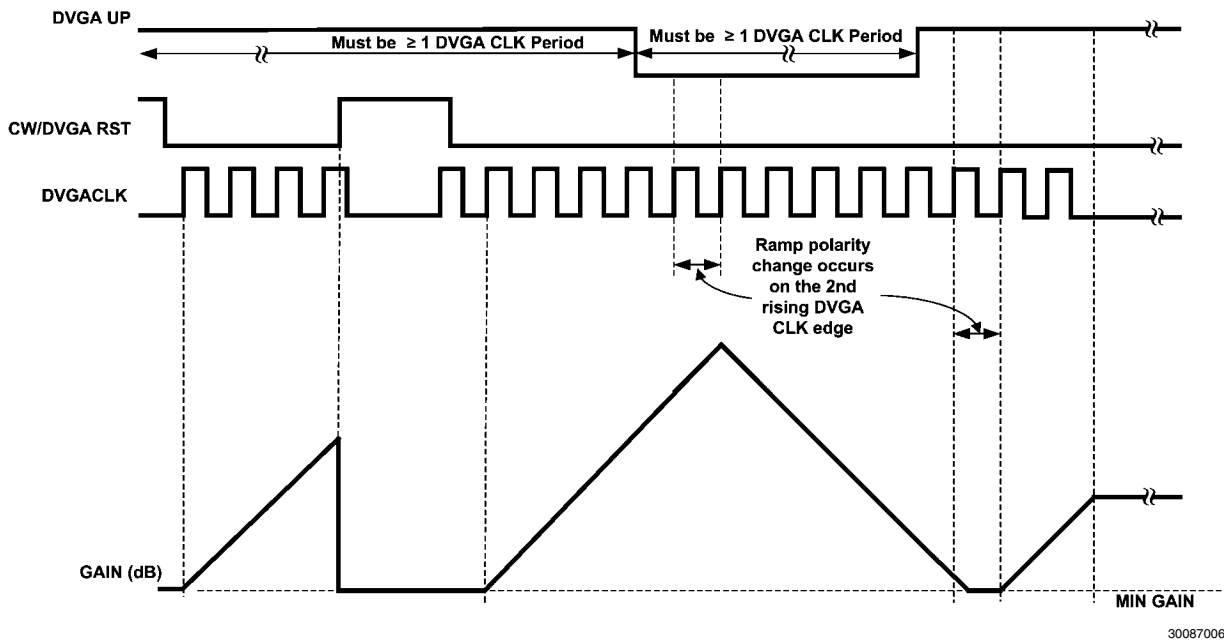

FIGURE 18. DVGA UP bit Change (Half-Step Disable bit = 1)

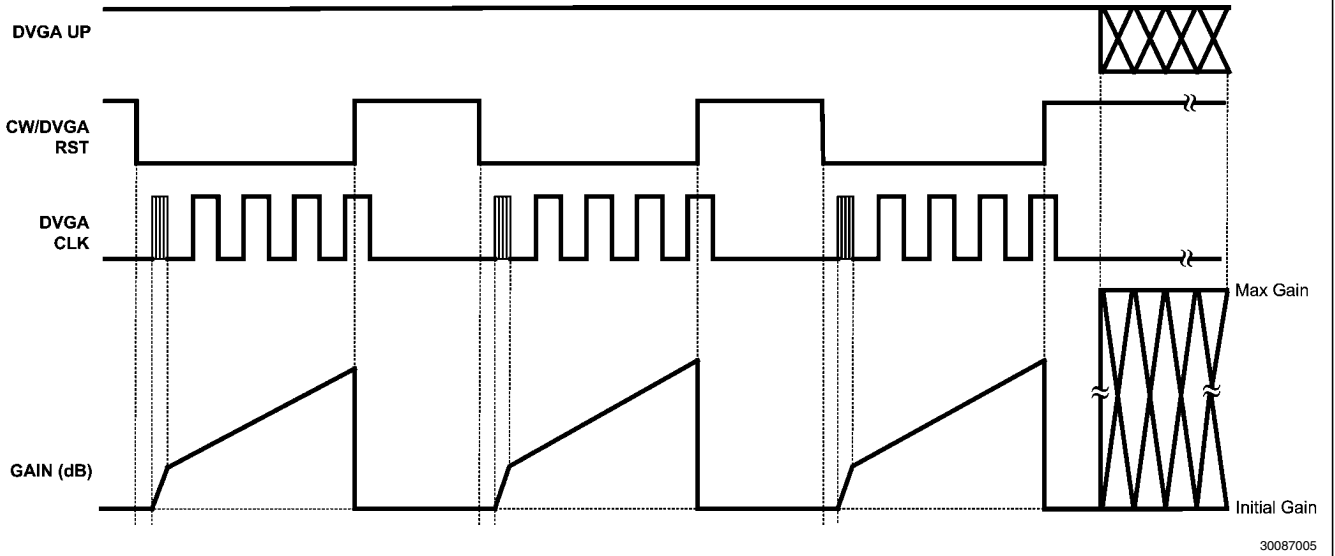

FIGURE 19. Periodic TGC Ramp: Example 2 (Half Step Disable bit = 1)

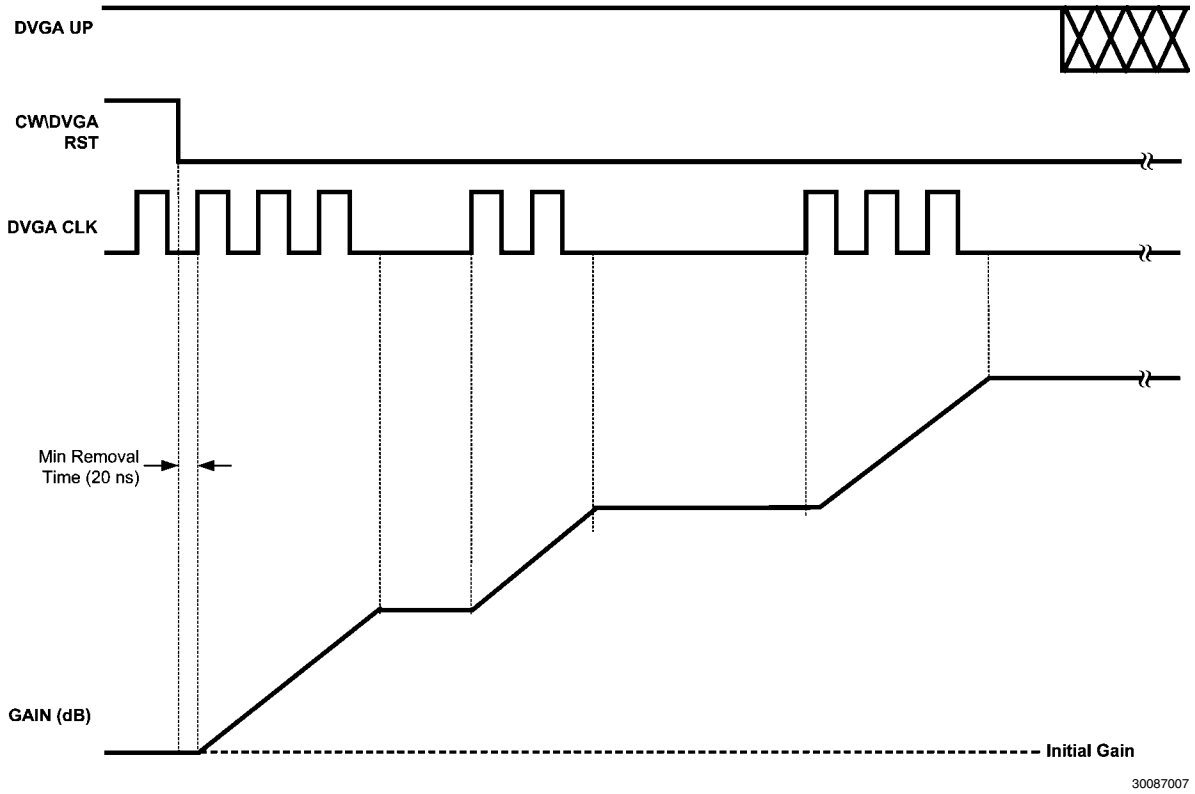
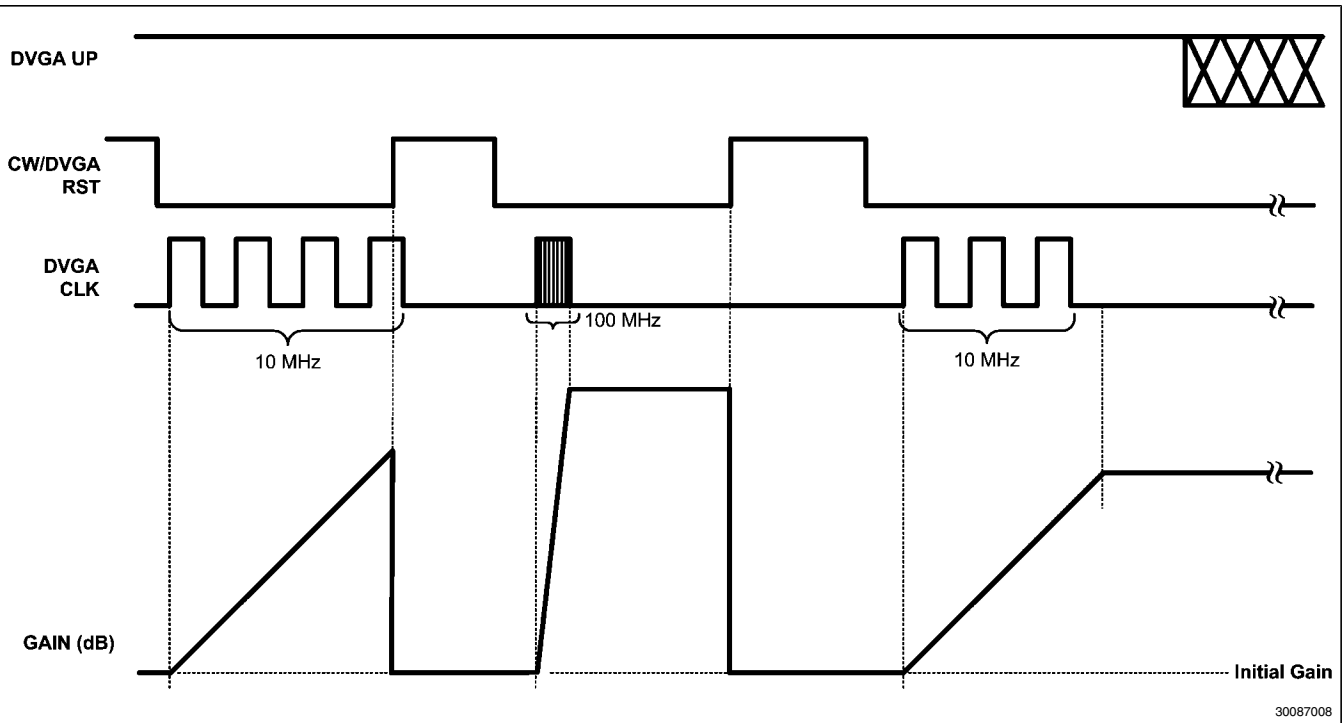
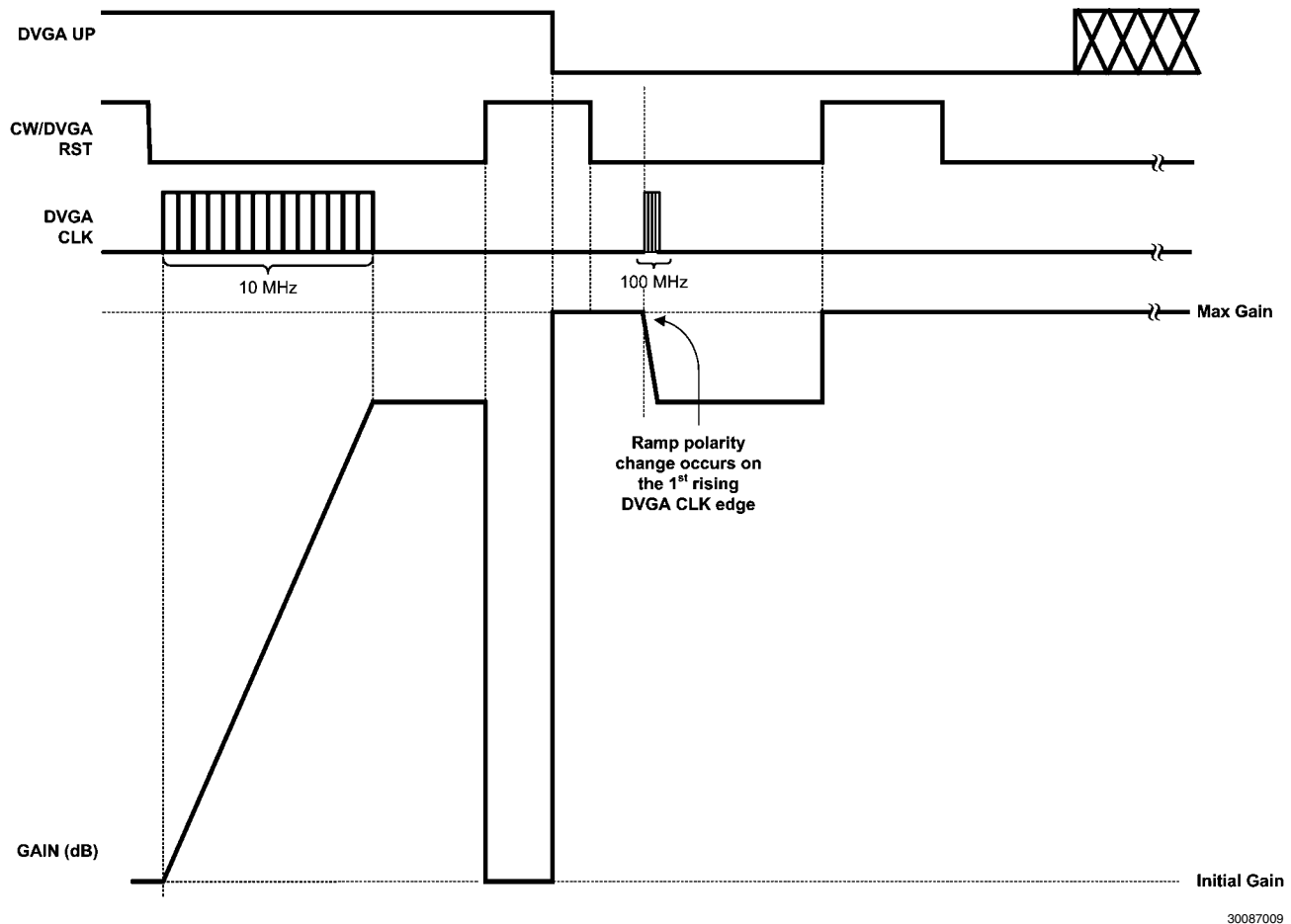

FIGURE 20. Basic Gain Adjustment (Half Step Disable Bit = 1)



30087008

FIGURE 21. Accelerated Gain Adjustment (Half Step Disable bit = 1)



30087009

FIGURE 22. Gain Reset with DVGA UP bit = 0

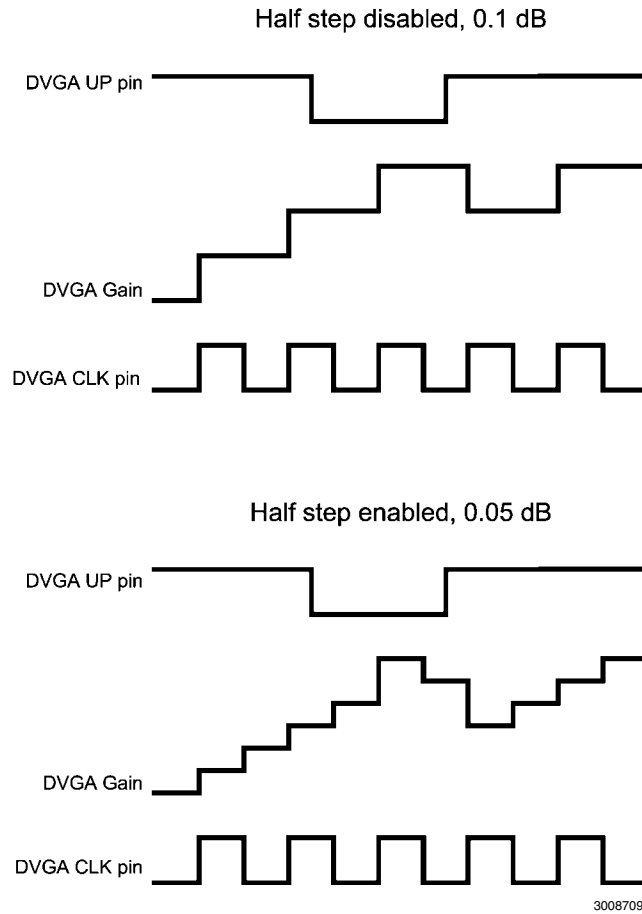

FIGURE 23. DVGA Gain control “Micro Illustration” of the Gain Stair Case

DVGA Half Step Mode

Another feature of the DVGA which makes it ideal for TGC (Time Gain Control) Applications is its ultra-fine gain step resolution. In its default startup state, the step attenuator is controlled with the clock and reset scheme described above, where each DVGA CLK rising edge changes attenuation by 1/2 step (0.05 dB typical), and the following DVGA CLK falling edge changes attenuation by another 1/2 step (0.05 dB typi-

cal). In other words one complete DVGA CLK cycle changes attenuation by 0.1dB. Alternatively, the Half Step mode may be disabled so that a gain step of 0.1dB will occur on the positive edge of the DVGA CLK and no gain change will occur on the negative edge of the DVGA CLK. The Half Step mode is controlled via SPI™ compatible interface register 0x1Ah, bit 3 (0x1A[3] = “1”, Half Step Disabled, 0.1dB step).

DVGA CLK Pin

The DVGA clock frequency determines the rate of change of attenuation (i.e. DVGA gain). The DVGA will increment or decrement gain by one step (0.05dB or 0.1dB) with each DVGA CLK cycle when CW/DVGA RST pin is low. The Maximum DVGA clock frequency is 100MHz which sets the maximum gain change rate at 10dB/μs. The minimum DVGA CLK pulse duration (either high or low state) is 4ns. To take advantage of Half Step DVGA clocking, it is recommended to keep DVGA CLK duty cycle close to 50%.

CW/DVGA RST Pin

When CW/DVGA RST is LOW, the step attenuator will increment or decrement attenuation with each DVGA CLK pulse. In the absence of DVGA CLK, the step attenuator will remain at its current attenuation until either CW/DVGA RST is pulled HIGH or a DVGA CLK pulse is applied. For example, assume DVGA UP is held HIGH while CW/DVGA RST is LOW and 74 clock cycles are applied. The attenuation is reduced by 74 steps or 7.4 dB. If CW/DVGA RST is still held LOW and 10 additional clock pulses are applied, the attenuation is further reduced by 1dB. If CW/DVGA RST is pulled HIGH, the attenuation will return to the DVGA Initial Attenuation (as shown in [Table 4](#)). The first positive CLK edge following a HIGH to LOW DVGA RST transition is valid and will increment or decrement gain depending on whether DVGA UP is HIGH or LOW respectively.

DVGA UP Pin:

DVGA UP pin determines the DVGA Initial Attenuation point and whether attenuation is decremented or incremented (i.e. DVGA gain increment or decrement respectively). If DVGA UP is HIGH, the DVGA gain will increment upwards, towards the Minimum Attenuation (Maximum Gain) limit of 0dB. If DVGA UP is LOW, the DVGA gain will decrement downwards,

$$T_{\text{attenuation}} = T_{\text{RST_width}} + T_{\text{RST_mem}} + 10\text{ns/step} \times (\text{Attenuation} / 0.1\text{dB/step})$$

For $0 \leq \text{Attenuation} \leq 15.9 \text{ dB}$ (DVGA UP = 0 during clocking)

$$T_{\text{attenuation}} = T_{\text{RST_width}} + T_{\text{RST_mem}} + 10\text{ns/step} \times ((32 - \text{Attenuation}) / 0.1\text{dB/step})$$

For $16 \leq \text{Attenuation} \leq 32 \text{ dB}$ (DVGA UP = 1 during clocking)

For example, with a 32 dB DVGA attenuation range, to achieve 20 dB DVGA attenuation, the time required is:

$$T_{\text{attenuation}} = T_{\text{RST_width}} + T_{\text{RST_mem}} + 10\text{ns/step} \times ((32 - \text{Attenuation}) / 0.1 \text{ dB/step})$$

$$T_{\text{attenuation}} = 200 \text{ ns} + 20 \text{ ns} + 10 \text{ ns/step} \times ((32 - 20) / 0.1 \text{ dB/step}) = 1.42 \mu\text{s}$$

THE LM96511 ADC

The LM96511 ADC employs a number of unique strategies to provide a high performance multi-channel AFE that offers a significant power consumption reduction when compared to competing architectures, as well as easing system level design. The ultra-low power performance of the LM96511 ADC is derived from the implementation of a fast continuous time sigma delta (CTΣΔ) modulator. Other features of this technology are:

- Intrinsic anti-alias filter: The digital decimating filter provides an intrinsic anti-alias filter, eliminating external

towards the minimum gain limit (38 dB of full attenuation assuming the “attenuation range setting” is at 38dB). DVGA UP can be dynamically switched during an increment or decrement operation.

After DVGA UP is switched from LOW to HIGH (or HIGH to LOW), the first positive edge of DVGA CLK synchronizes the new state with the DVGA CLK. The second positive edge of DVGA CLK will decrement (or increment) the DVGA Gain.

DVGA Accelerated Gain Adjustment:

With the LM96511's clock and reset scheme and the ability for a high frequency DVGA clock (max = 100MHz), it is possible to get to the desired TGC starting point quickly. Assuming a DVGA “attenuation range setting” of 32dB selected, the fastest way to achieve DVGA attenuations of 16-32 dB is to apply a CW/DVGA RST pulse with DVGA UP HIGH (to get to 32dB attenuation) followed by a succession of DVGA CLK pulses sufficient to get to the attenuation level desired. For attenuations from 0-15.9 dB, it is faster to apply a CW/DVGA RST pulse with DVGA UP LOW (to get to 0dB attenuation) and followed by a succession of fast DVGA CLK pulses. [Figure 21](#) and [Figure 22](#) illustrate examples of this feature in order to explain the accelerated gain adjustment sequence more clearly.

In certain instances, an important parameter may be the time required for this operation (i.e., “T_attenuation”). Starting from the rising edge of the CW/DVGA RST pulse, the total time is the sum of the CW/DVGA RST minimum pulse width (“T_RST_width” = 200ns), the minimum time required to start the DVGA CLK from the CW/DVGA RST's LOW state (i.e., “DVGA RST removal time” which is listed in the Electrical Characteristics Table as, “T_RST_rem” = 20 ns), and the time required to clock the DVGA to achieve the desired attenuation (“Attenuation” in dB):

analog filter components, and simplifying multi-channel designs.

- Instant overload recovery (IOR) system guarantees extremely fast recovery from overload (< one clock cycle), and no settling errors on return from overload.
- Ultra-low inter-channel crosstalk.
- Digital Equalizer provides low group delay and hence minimizes signal path delay variation.

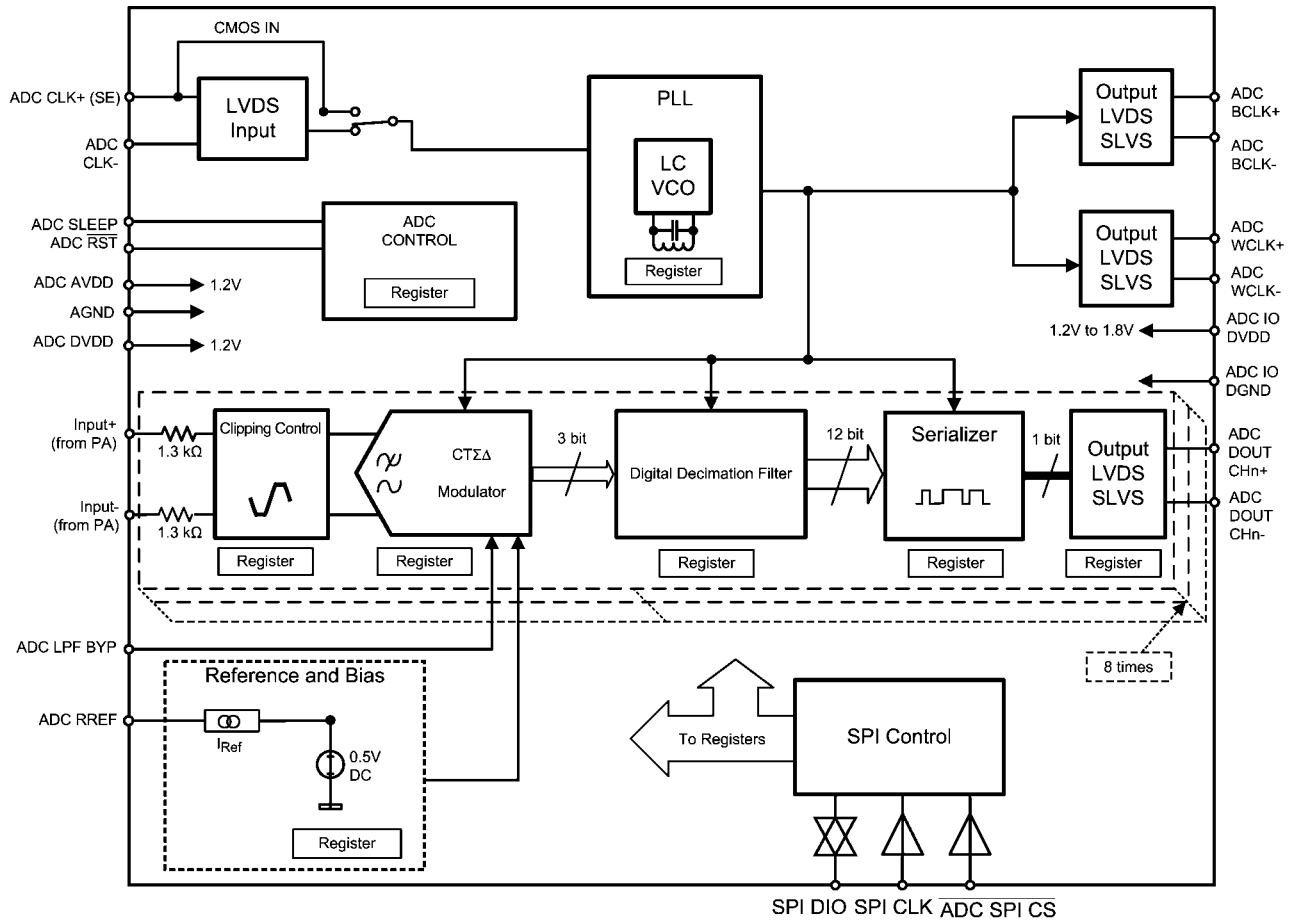

30087040

FIGURE 24. LM96511 ADC Block Diagram

The major components of the LM96511 ADC, shown in [Figure 24](#), are: clipping control; CTΣΔ modulator; digital decimation filter; 12-bit serializer; and finally the LVDS/SLVS outputs. The PLL is critical to the operation of the LM96511 ADC, and the PLL also provides the bit and word clock outputs. The SPI™ Compatible Control Interface gives uncomplicated user access to the ADC registers.

ADC OUTPUT INTERFACE

The ADC outputs provide a sampling clock and data information. The output sampling or bit clock is a differential high speed bit clock that is 6 times the input clock and 90° out of phase with respect to the output data information. This clock is automatically synchronized to the input ADC clock within the LM96511. However, this bit clock is not phase aligned with the input ADC clock.

The output data information consists of two components: the serialized ADC output data and the output word or frame

clock. Each serialized data word or frame is 12-bits wide. The word clock output provides framing information necessary for deserialization of the data by identifying the bit boundary of each data word sample. The word clock is a lower frequency clock that is phase aligned (within a very small skew, t_{DWS}) with the data and is primarily used as a strobe to capture and align data words in a parallel register within the deserializer. The rising edge of the word clock is aligned (within a very small skew) with the LSB of a data word output from the ADC. The word clock signal is sampled on the positive and negative edges of the bit clock output. Thus, a rising edge of the word clock indicates that a full data word is available to load into a deserializer's parallel register and that a new data word begins. This word clock is not phase aligned with the input ADC clock.

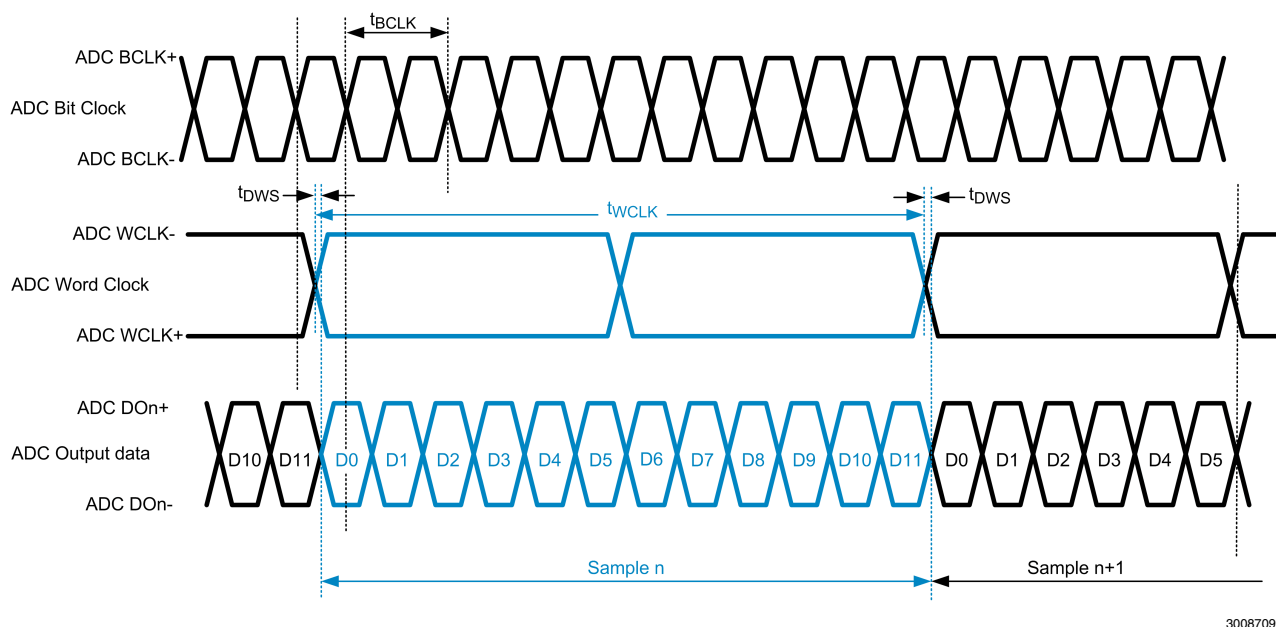

30087099

FIGURE 25. ADC WCLK

12-BIT SIGMA DELTA ($\Sigma\Delta$) ADC CORE

The LM96511 ADC comprises eight analog ADC channels using a CT $\Sigma\Delta$ architecture, which provides very high dynamic performance with ultra-low power, while operating from a minimal 1.2V supply.

The CT $\Sigma\Delta$ ADC architecture uses a third order sigma delta modulator operating at a nominal 16 times over-sampling rate in combination with a 3-bit quantizer. The modulator output is coupled to a power efficient digital decimation filter that decimates the high rate modulator output (640 to 800 MHz) to provide output data at a sample rate between 40 MSPS and 50 MSPS. A benefit of the CT $\Sigma\Delta$ design is that the ADC requires no external anti-alias filters for most applications. This benefit is derived from a combination of the design of the analog sigma delta modulator and digital decimation filter. The digital filter achieves a steep transition band, and provides 72 dB of attenuation in the stop band. Using the digital equalizer, the signal transfer characteristics including phase performance can be optimized so as to minimize group delay variation. In applications where it is not required, the digital equalizer can be disabled to further save power.

INSTANT OVERLOAD RECOVERY

The LM96511 features an overload handling system which provides instantaneous recovery from signals driving the ADC inputs beyond the full-scale input range. The ADC can operate in two different modes. In the default ADC mode (IOR Off mode) a full-scale input range of $4.2 V_{PP}$ is supported, here the ADC operates with some inherent overload recovery time, similar to a conventional ADC.

In the IOR On mode, the ADC has a reduced $3.2 V_{PP}$ full scale input range, but provides a significant benefit in that the ADC can now be driven by input voltages as high as 5 dB beyond the nominal full-scale ($f_{IN} < 12$ MHz), that is $5.7 V_{PP}$, and will recover instantaneously. In a number of applications this feature can help simplify input stage design and manufacturing set-up and calibration. The LM96511 recovers immediately from overload with no missing codes and no settling time.

The proprietary strategy used within the LM96511 ADC uses high speed patented clamp techniques to limit the input signal and keep it within the stable input range of the ADC. This process happens at a speed equivalent to the on-chip over-sampling rate of 640 to 800 MHz. The advantage of this system is that it responds immediately to out of range signals. While the inputs are over-range the ADC outputs a full scale result. As the over-range input is removed the ADC adjusts to the input signal level and is able to provide sampled data instantaneously. The LM96511's behavior on emerging from overload is repeatable and independent of whether the input signal was positive or negative going at the point of overload.

USING IOR ON MODE

As discussed earlier, IOR On mode provides instantaneous recovery from overload conditions, with no ringing and correct data output as soon as the input returns in range.

Standard Use of IOR On Mode

The recommended way to enable IOR On mode is by setting bit 4 (IOR) of the Modulator Overload Control register (02h). Setting this bit will enable IOR mode with the default settings for Digital Gain Factor (DGF) in the Decimator Clipping Control register (0Ah) and OL in the Modulator Overload Control register (02h). Setting the IOR mode bit to 0 will restore DGF and OL to their default values, hence putting the LM96511 back into IOR Off mode.

As can be seen in the Electrical Specifications, using IOR On mode gives a slight reduction in SNR performance, and also a reduction of the full scale input range to $3.2V_{PP}$ differential.

Advanced Use of IOR On Mode

The registers described above allow the user to customize IOR On mode. In order to correctly set the DGF and OL values, it is necessary to understand how the IOR On mode functions. The implementation of IOR On mode in the LM96511's ADC consists of analog and digital parts working in tandem.

The analog clipping circuitry, controlled by OL, is designed to protect the sigma delta modulator from large signal inputs. Using an analog clamp, signals are soft-limited to the less than the $4.2V_{PP}$ full scale range of the modulator. OL gives the value at which the circuit will begin to clamp.

The digital filter of the ADC12EU050 is where the full scale input range is selected and the hard limiting of the signal takes place. DGF selects the gain of the digital filter, and hence the new full scale input range of the ADC.

In order to set a custom value for DGF, Custom Gain Setting (CGS), bit 7 of the Decimator Clipping Control register (0Ah), must be set. The DGF can then be set, based on the application requirements. OL should then be set to a value approximately half-way between the new full scale input range (which was just selected by DGF) and the default full scale input range of $4.2V_{PP}$. OL must be set to a value higher than DGF, otherwise the signal will be limited by the analog clipping circuitry, rather than the digital circuitry, and overload recovery will be impacted.

INTEGRATED PRECISION LC PLL ADVANTAGES

The LM96511 ADC includes an integrated high performance “clean up” phase locked loop (PLL), simplifying the need for a low jitter external clock for ADC CLK pin(s). The PLL serves three important functions; it generates a highly accurate internal sampling clock source of up to 800 MHz; a clock for the LVDS serializers at 600 MHz; and it provides a low jitter clock for other internal components. With its jitter clean-up capability this PLL allows lower performance system clocks to be used.

The ADC CLK pin(s) are AC coupled within the LM96511 so that the common mode voltage is not critical. The clock can be single ended or differential (unused ADC CLK input can be grounded). A single ended clock input should be connected to ADC CLK+ (B22) pin, and ADC CLK- (A22) pin should be grounded. Furthermore, the ADC CLK source can be a sine or square wave for maximum flexibility. Datasheet parameter testing is done with a “clean”, differential square wave clock source routed as 100Ω differential pairs, and terminated with a 100Ω resistor close to LM96511 clock inputs.

The benefit of having an on chip PLL is that in most applications a high precision clock source is not required. The impact of aperture jitter on the ADC’s performance is reduced dramatically by the jitter clean-up properties of the PLL, which ensures that any RMS jitter outside of the PLL bandwidth is attenuated. The PLL also significantly relaxes the input clock duty cycle requirements, accepting input clock duty cycles of 20% to 80%.

The PLL offers two choices of bandwidth, selectable by SPI™ register 03h[1] (SHBW). For the majority of systems, the default bandwidth of 415 KHz is suitable. If the system already contains a high performance clock, with excellent RMS jitter performance up to a 1.5 MHz bandwidth, then the PLL’s high bandwidth mode can be used.

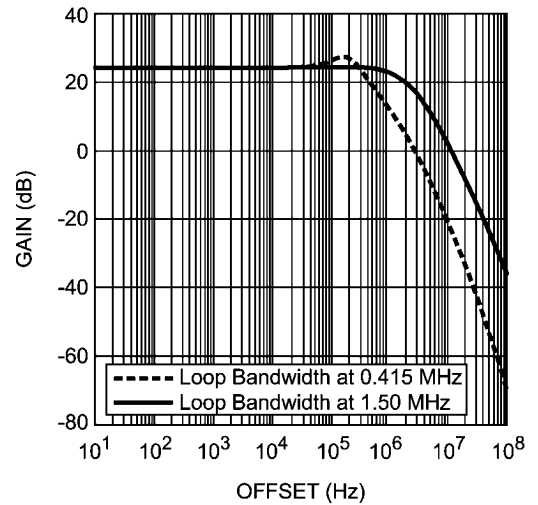

30087041

FIGURE 26. PLL Phase Noise Transfer Function: ADC CLK = 40 MHz

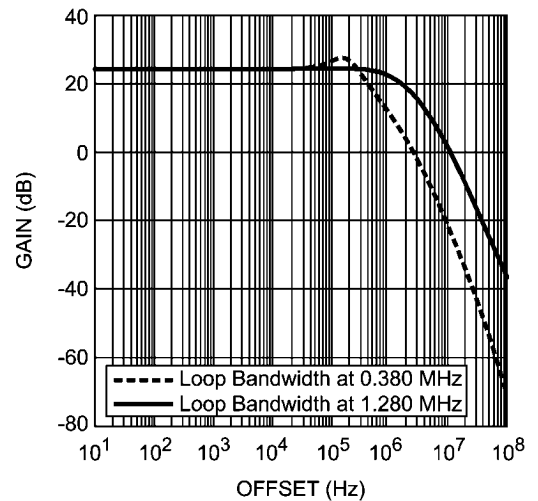

30087042

FIGURE 27. PLL Phase Noise Transfer Function: ADC CLK = 50 MHz

On the input clock, excessive RMS jitter within the PLL bandwidth will be seen in the output spectrum as sidebands, or close in phase noise, around the fundamental signal.

DIGITAL DECIMATION FILTER AND EQUALIZER

The digital decimation filter is an integral part of the sigma delta architecture. It decimates the over-sampled data from the modulator down to the sample rate, and its extremely sharp low pass characteristic combined with the modulator’s broad band response provides the intrinsic anti-alias filter. The digital low pass filter exhibits 72 dB of attenuation in the stop band. [Figure 28](#) shows the digital filter transfer function at 40 MSPS, compared to a third order Butterworth transfer function.

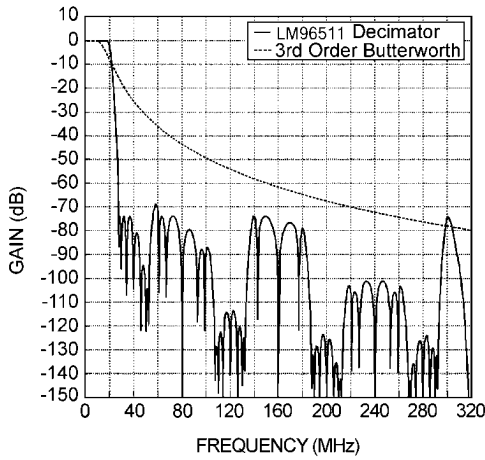

30087043

FIGURE 28. Digital Filter Transfer Function

Due to the digital implementation of the filter, the filter parameters automatically scale with the ADC sampling frequency. Such steep digital filters introduce group delay problems, but the LM96511 ADC includes a digital equalizer, which reduces group delay ripple variation to less than 0.05 samples. In applications where group delay is not of concern, the equalizer can be turned off through the SPI™ interface (register address 0Bh) in order to save power.

Figure 29 and Figure 30 show the group delay ripple of the digital decimation filter at 50 MSPS, firstly with the equalizer disabled, and secondly with the equalizer enabled:

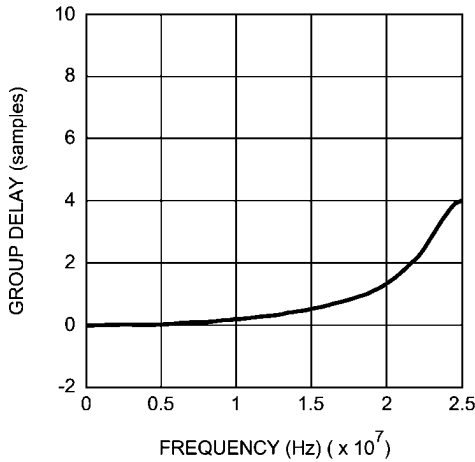

30087048

FIGURE 29. Group Delay with Equalizer Off

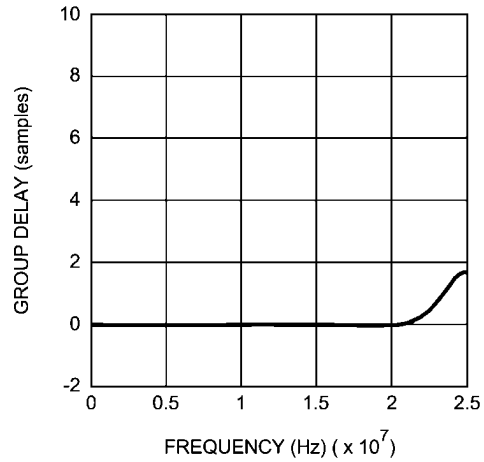

30087049

FIGURE 30. Group Delay with Equalizer On

OUTPUT CLOCK SYNCHRONIZATION ACROSS MULTIPLE CHIPS

In systems containing more than one LM96511, it is often required that the timing of output samples is synchronized across the multiple chips. The PLL in the LM96511 ADC takes care of this automatically by frequency-locking the output clocks with the input clock for each LM96511 device. However, the user must still ensure, using correct board layout and clock buffering techniques, that the input clock to each LM96511 ADC (ADC CLK) is synchronized to each other. If this is the case, then the output bit clocks from each LM96511 ADC will also be synchronized. This means that output samples are aligned with each other.

CAPACITOR SELECTION

The ADC LPF BYP pin provides the capacitance for the low pass filter between the DAC bias block and the DAC in the sigma-delta modulator. The filter blocks noise from the DAC Bias block from entering the DAC. Any noise which passes through this filter will be seen in the spectrum as side skirts around the carrier. The filter circuit, which is a first order RC filter, is shown in Figure 31

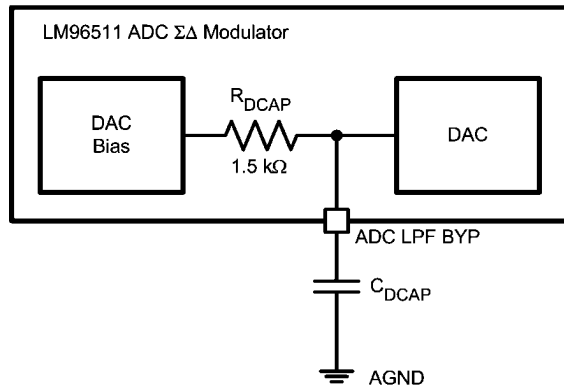

30087044

FIGURE 31. DAC LPF Capacitor

The ADC LPF BYP pin must be connected to AGND through a low leakage, minimum 100 nF capacitor. If the application is especially sensitive to close to the carrier phase noise, then it is recommended to increase C_{DCAP} , up to a maximum of 10 μ F. For other applications where close to the carrier phase noise is not important, the capacitor can be kept small in order to reduce costs and minimize board space. The corner frequency of this filter is determined by the equation:

$$f = \frac{1}{2\pi R_{DCAP} C_{DCAP}}$$

ADC OUTPUT CONSIDERATIONS

The LM96511 offers a variety of output settings in order to cater for different system design and integration needs

Output Driving Voltage, ADC IO DVDD

The ADC output driver voltage, ADC IO DVDD, can be set between 1.2V and 1.8V. An ADC IO DVDD of 1.2V will offer the lowest power consumption. Because ADC IO DVDD can be varied, the LM96511 provides, via the SPI™ registers, the ability to adjust the output common mode voltage.

Output Modes and Output Common Mode

Three different output modes are also supported: SLVS, LVDS and reduced common mode LVDS. SLVS and LVDS modes output data according to their respective specifications. Reduced common mode LVDS must be used when the output driver voltage, ADC IO DVDD, is 1.2V. The standard LVDS common mode voltage is 1.2V, which is obviously not feasible if ADC IO DVDD is 1.2V. Therefore, the output common mode voltage must be set to 1.0V by setting the bit OCM in the LVDS Control Register to 0.

When ADC IO DVDD is 1.8V, the standard LVDS common mode voltage of 1.25V must be used, by setting OCM (SPI™ Register 0Ch) equal to 1. Table 2 summarizes these different output modes:

TABLE 1. ADC Output Mode Summary

Output Mode	ADC IO DVDD (V)	SPI™ Register 0Ch[1] (OCM)	SPI™ Register 0Ch[0] (SLVS)	Output Common Mode (V)
Reduced CM LVDS	1.2	0	0	1.0
LVDS	1.8	1	0	1.25
SLVS	1.2	X	1	0.175

SLVS mode offers the lowest power consumption followed by reduced common mode LVDS and then the standard LVDS. As well as the different output modes, the output drive current can also be controlled via the LVDS Control Register. The default output drive current is 2.5 mA, but this can be increased to 3.5 mA or 5 mA, depending on output trace routing and receiver requirements. Power consumption of the LM96511 will increase slightly as the output driver current is increased.

Termination

The final control feature available in the LVDS Control Register is the choice between internal and external 100 Ω termination. Although the termination is recommended to be as close to the receiver as possible, in some cases it may be necessary or desirable to perform this termination at the transmitter. Internal 100 Ω termination at the transmitter (the LM96511) is enabled by setting the SPI™ register bit TX_term to 1.

LVDS Output Training Sequences

Often it is necessary to calibrate the LVDS receiver, for example an FPGA or DSP, so that skew between the eight ADC output channels is minimized. In order to simplify this process, the LM96511 provides three LVDS training modes, where a pre-defined or custom pattern is output on all eight channels simultaneously. While a training mode is active, the word and bit clocks are output as usual. In order to select a training mode, the TSEL bits of the Decimator Control Register (0Bh) must be programmed via the SPI™ compatible interface.

There are two pre-defined training patterns, or a custom pattern can be loaded via the SPI™ compatible interface into the Serializer Custom Pattern 0 and 1 Registers (08h and 09h). In order to return to normal ADC operation after skew calibration, the TSEL bits should be returned to their default value of 00.

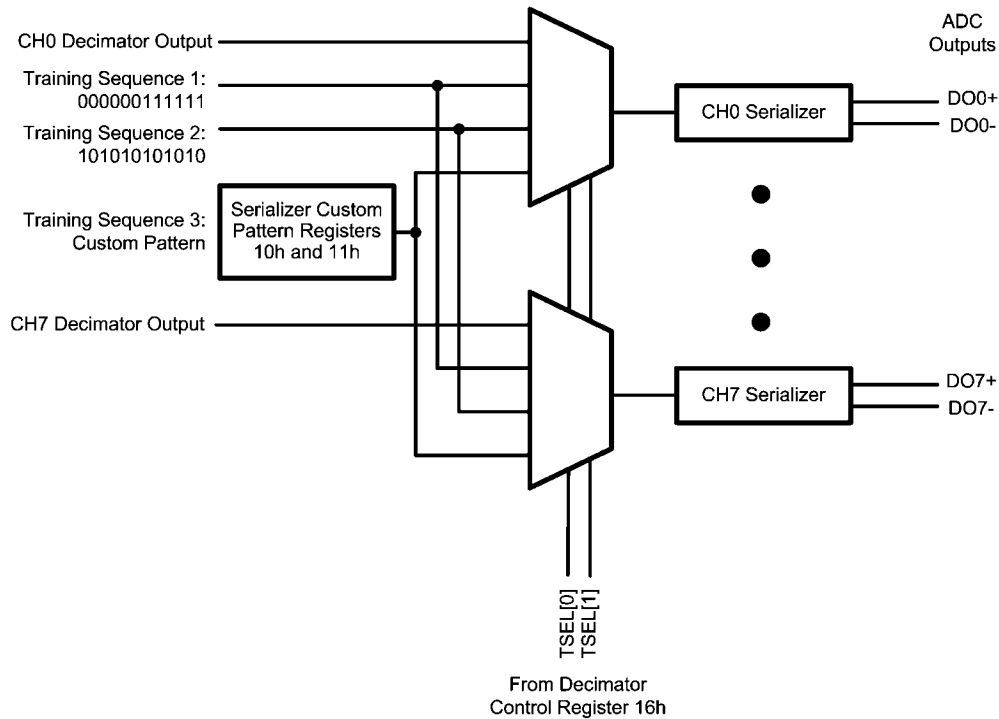

30087046

FIGURE 32. LVDS Training Sequence

The Voltage Reference

The LM96511 ADC provides an on chip, $\pm 5\%$ tolerance voltage reference (ADC RREF), together with all necessary biasing circuits and current sources. A $10\text{k}\Omega$ ($\pm 1\%$) resistor (RREF) must be connected between ADC RREF and AGND in order to establish the biasing current of the ADC.

If a tighter tolerance reference is required for improved thermal stability, an external voltage reference can be connected between the ADC VREF and AGND pins. This external ref-

erence must be able to support a $20\text{k}\Omega$ internal load tied to the internal voltage reference (500 mV nominal). The RREF resistor must be connected even when using an external reference.

When using the internal reference, ADC VREF should be connected to AGND through a 100 nF capacitor. Chip-to-chip gain matching between several LM96511 ADCs can be improved by connecting the ADC VREF pins of the ADCs. This is shown in [Figure 33](#):

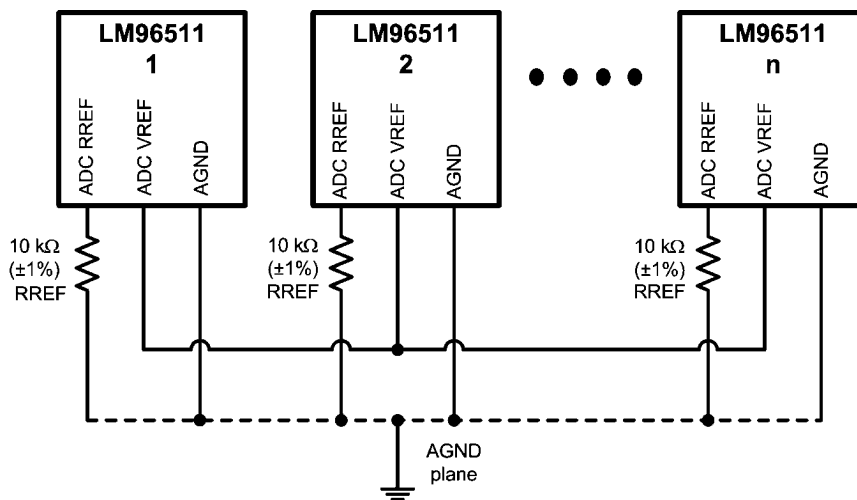

30087047

FIGURE 33. Reference Sharing

CW Doppler Section Theory of Operation

As illustrated in [Figure 34](#) below, the LM96511 includes a CW Doppler demodulator for analog beamforming in ultrasound applications. Eight single-ended in-phase (CW I Chx) and quadrature (CW Q Chx) output pin currents (16 total pins for 8 channels) are summed together using an external summing amplifier (one each for I and Q outputs) as shown. Each channel's phase can be controlled in 22.5° increments using a 4 bit phase code with an SPI™ compatible interface register. With a common RF input applied to all channels and the same phase code programmed, all 8 channels' outputs will be nominally in phase (I to I and Q to Q). If, for example, Channel 5's phase code is changed from the default value of 0000 to 0101, the Channel 5 output will lead any Channel with phase code 0000 by $112.5^\circ (= 5 \times 22.5^\circ)$. With N-phase-aligned channels summed together, the SNR increases by \sqrt{N} or 3 dB every

time N doubles, since the CW Doppler signal increases by N but uncorrelated noise increases by \sqrt{N} . Similarly, the LNAs and demodulators do not share any references or internal functions in order to keep their noise contributions uncorrelated.

The CW Doppler section requires a differential 16x Local Oscillator (LO) input (CW CLK inputs in). The clock source used must have high fidelity and low phase noise to maintain low Doppler phase noise. The typical LO common mode (CM) level is 1.2V with a 0.4Vpp differential swing (100Ω differential source). Internally, the LO input is divided by 16 and fed to doubly-balanced demodulators. The LO duty cycle should be close to 50%. A Doppler Reset pin is provided (CW/DVGA RST) which resets all the LO dividers to allow synchronization by placing the divider's individual counters in a known state. This allows several LM96511's to be used with additional channels.

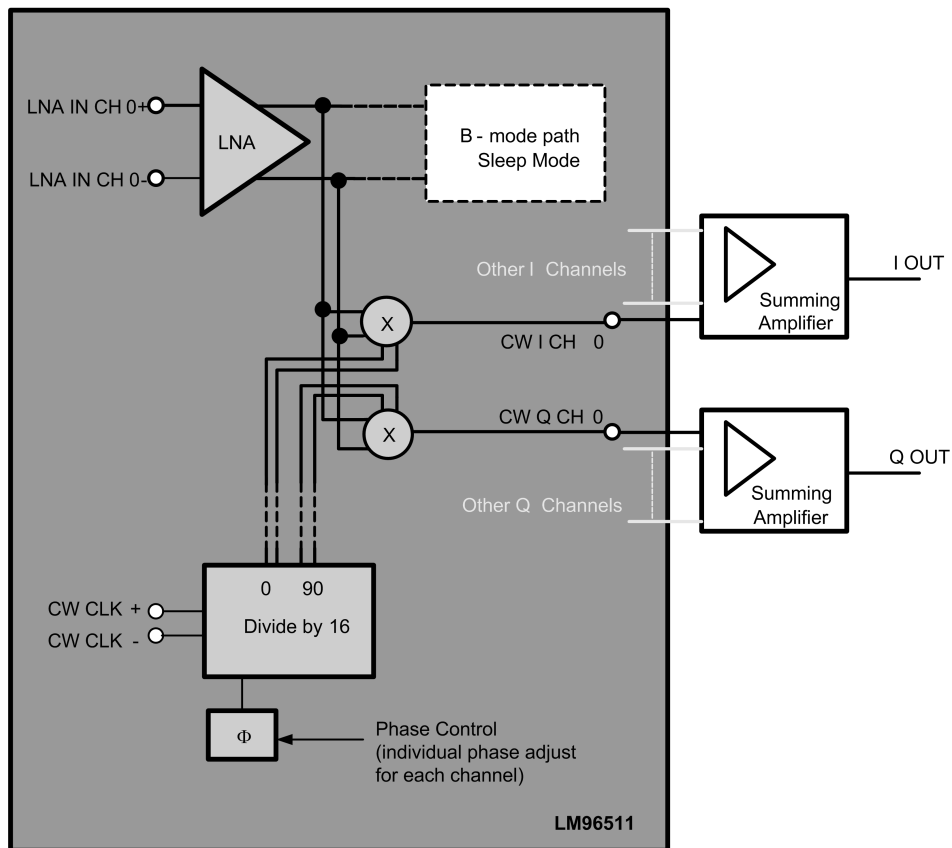

30087050

FIGURE 34. Signal Path (CW Doppler) Single Channel

Individual I and individual Q outputs are summed together using a single-supply summing amplifier which observes the LM96511 Doppler output compliance range (2.1V to 3.6V). [Figure 35](#) shows one such implementation employed on the LM96511 Reference Board (available for purchase from National Semiconductor):

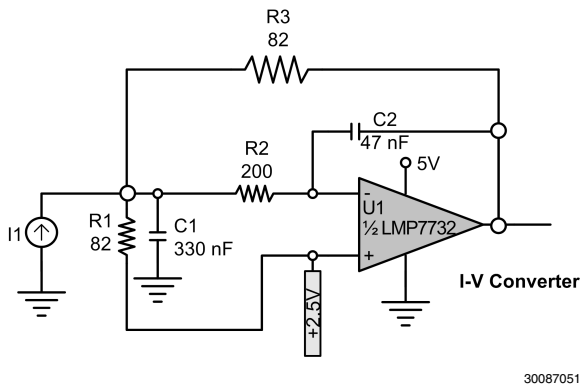

30087051

FIGURE 35. I-V with Integrated 2-Pole LFP

It is important to be mindful of noise, especially 1/f noise in the power supplies, particularly the “+2.5V” supply tied to the non-inverting input of the summing Op Amp.

A low noise Op Amp (LMP7732) is selected for this application to minimize the noise impact. The “I1” current source represents a single output current from the CW Doppler section of the LM96511. Other outputs can be paralleled together. The I-V converter output is then AC coupled to a 24-bit ADC (Asahi-Kasei (AKM) Part # AK5386VT) input for acquisition and processing. The use of a high bit count (or pro-audio grade) ADC is essential in keeping the noise floor low to maximize SNR.

The I-V converter of *Figure 35* is biased for single supply ($V_{CC}=5V$) operation with its non-inverting input tied to a low noise +2.5V reference. The Feedback action ensures low CW DOPPLER output compliance. The 2nd order Butterworth LFP in *Figure 35* has a passband gain of $\sim 38 \text{ dB} \cdot \Omega$ ($=R3=82 \text{ V/Amp}$). *Figure 36* shows the I-V converter’s transfer function:

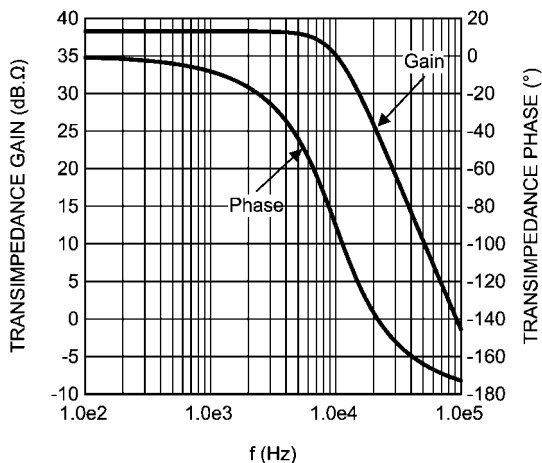

30087052

FIGURE 36. CW Doppler LFP Gain/Phase Characteristics

With a typical $\pm 4.2 \text{ mA}$ from each CW DOPPLER output and 4 channels summed together, the Op Amp output voltage is $\pm 1.38V$ ($= \pm 4.2 \text{ mA} \times 4 \times 82 \text{ ohm}$) from $V_{CC}/2$, which can be supported with a single 5V supply and the op amp’s Rail-to-Rail output. The LMP7732 has approximately 17 mA ($\pm 4.2 \text{ mA} \times 4$) output current capability required when its output is at least 0.4V away from either rail, which is the present case.

The LFP in *Figure 35* has a -3dB bandwidth of 10 KHz, suitable for CW Doppler blood flow applications. The Doppler shift expression below shows the shift in frequency as a function of target speed:

$$\Delta f_D = \pm \frac{2\Delta v}{\lambda} \cos \theta$$

where:

- Δf_D = Change in frequency (CW Doppler output tone frequency) (Hz)
- Δv = Speed difference between target and ultra source (m/s)
- λ = Wavelength of ultra-sound signal (m/cycle)
- θ = Angle between incident wave and the velocity vector of the moving target

With a typical ultrasound propagation speed of 1540 m/s and 5MHz repetition rate, the wavelength, λ , is 308 $\mu\text{m/cycle}$. Assuming a 0° incidence angle, blood flowing at around 15 cm/s will produce a frequency shift of 974 Hz:

$$\frac{2 \times 0.15(\text{m/s})}{308(\mu\text{m/s})} \times \cos(0)$$

CW DOPPLER NOISE ANALYSIS

The combination I-V converter & LFP of *Figure 35*, slightly degrades the LM96511 Doppler output noise. From the CW Doppler Electrical Characteristics Table, with 53 pA/ $\sqrt{\text{Hz}}$ typical RMS noise from each of the four LM96511 outputs summed, one can expect 8.7 nV/ $\sqrt{\text{Hz}}$ ($= 53 \text{ pA}/\sqrt{\text{Hz}} \times 82 \Omega \times \sqrt{4}$) of typical RMS noise voltage density at the I-V converter output, assuming a noiseless I-V converter.

The I-V converter noise contribution is dominated by the LMP7732’s voltage noise ($= 2.9\text{nV}/\sqrt{\text{Hz}}$) and its noise gain ($\cong (1+R3/R1) = 2V/V$ passband approximation) resulting in 5.8nV/ $\sqrt{\text{Hz}}$ typical rms noise at the output. Resistor (R1-R3) thermal noise accounts for another 3.9nV/ $\sqrt{\text{Hz}}$ for a total RSS noise of 7nV/ $\sqrt{\text{Hz}}$ at the I-V converter output. The impact on the LM96511 related noise is 2.3 dB :

$$20 \times \log \frac{\sqrt{(7.0 \text{ nV}/\sqrt{\text{RtHz}})^2 + (8.7 \text{ nV}/\sqrt{\text{RtHz}})^2}}{8.7 \text{ nV}/\sqrt{\text{RtHz}}}$$

With a 10 kHz LFP and the LM96511’s typical $\pm 3\text{mA}$ current from each output, and assuming a sinusoidal peak-to-RMS ratio of $\sqrt{2}$, one can expect a SNR of 119 dB:

$$20 \times \log \frac{3 \text{ mA} \times 8 \times 82 \Omega \times 1/\sqrt{2}}{\sqrt{(7 \text{ nV})^2 + (8.7 \text{ nV})^2} \times \sqrt{10 \text{ kHz}}}$$

Note that the LMP7732’s low 1/f noise corner frequency ($= 3\text{Hz}$) helps in keeping the 1/f noise inconsequential thus maintaining high SNR.

Figure 37 shows an implementation of 64 CW Doppler receive channels for either “I” or “Q” outputs. Each LM96511 CW Doppler output is represented by a current source symbol. In this implementation, each primary I-V converter (U1) handles 4 channels while U2 sums the outputs of all I-V converters. R4, R5, C3, and C4 form a combination high-pass and low-pass filter that strips the DC component and attenuates the

signals beyond ~50 KHz. Analog switch S1 is used to selectively shutdown channels; Often, a 128 channel ultrasound system operates with 64 receive channels. Switches S2 and S3 are used to set the overall gain. This is commonly done to optimize dynamic range depending on the target Doppler

echo. The U2 gain is set for FS output (3V_{pp} in this case) with offset frequency signal amplitudes typically 20 dB down from the FS CW Doppler output, or about ±0.42 mA from each LM96511 output.

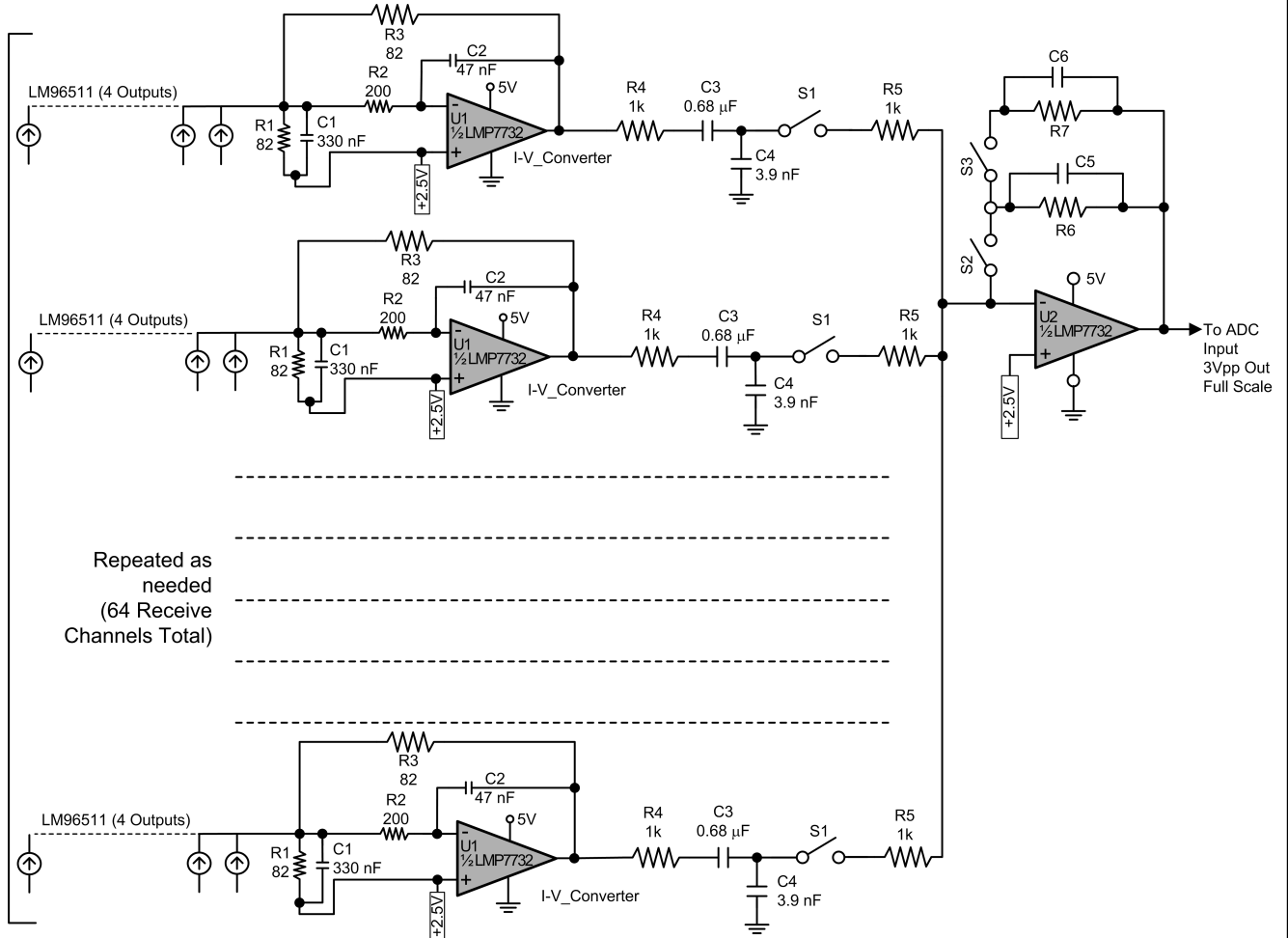

30087079

FIGURE 37. CW Doppler Output (I or Q) Implementation (64 Receive Channels)

CW DOPPLER 16x LO SOURCE IMPLEMENTATION

In order to achieve the phase noise performance specified in the Electrical Characteristic table, the CW_Doppler 16x LO source (CW CLK input pins) should have low jitter (low phase noise). The performance specifications reflected in this datasheet were obtained with highly accurate 80 MHz (for 5MHz CW_Doppler signal) sources made by Wenzel Associates, Inc. Their oscillators exhibit ~ -165 dBc/ Hz @ 10 KHz phase noise. The 16xLO implemented in the LM96511 Ref-

erence design, uses a lower cost oscillator from Vectron International, which exhibits acceptable phase noise performance (-145 dBc/Hz @ 10 KHz) in conjunction with National Semiconductor's LMK01000 low phase-noise clock buffer-divider chip. By dividing down from a higher frequency source, one can achieve 6dB of improvement in phase noise for every divide-by-two. The block diagram below shows this in more detail:

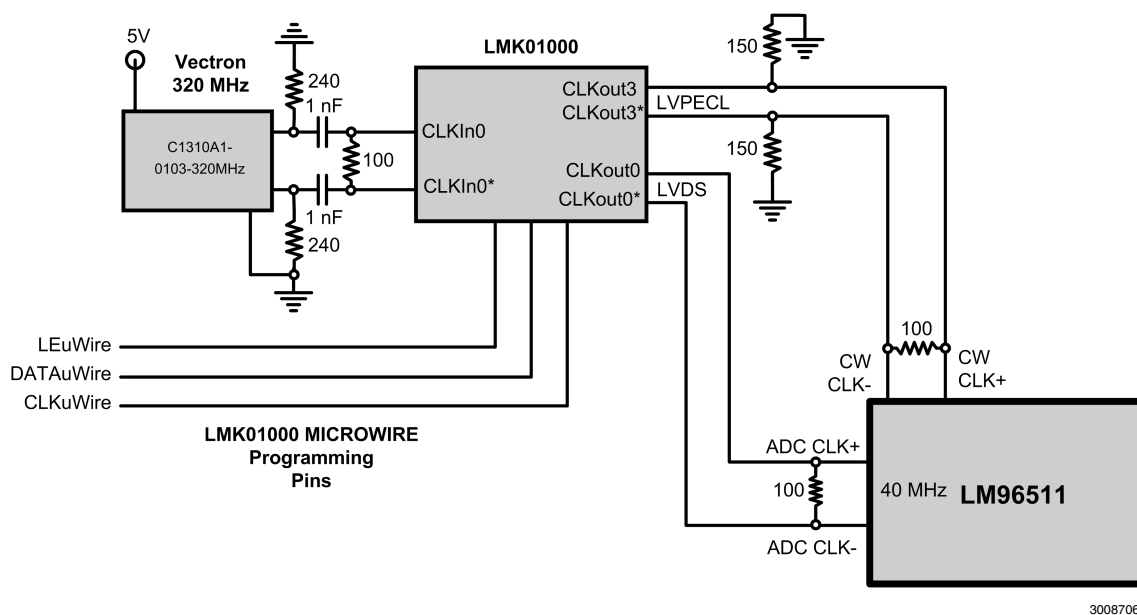

FIGURE 38. CW Doppler Low-Phase Noise Clock Source Design

In [Figure 38](#), a low phase noise 320 MHz source is divided by 4 (MICROWIRE programmable) in an LMK01000 to provide an 80.0 MHz CW CLK for a 5.0 MHz ultrasound signal. Other LMK01000 outputs are available for auxiliary functions like the 40 MHz B-mode ADC clock. Keep in mind however that

the low-phase noise of this approach is not required by the B-mode ADC CLK because of its integrated PLL.

The faster edges and lower signal swing of the LMK01000's LVPECL outputs (CLKout3-7) provide better phase noise performance (lower jitter) than the LVDS outputs (CLKout0-2).

LM96511 Power Management

TABLE 2. LM96511 Power Consumption for Various Conditions

AMP CW/ DVGA & ADC CW/DVGA Pins	Operating Condition	LNA	DVGA	Doppler Demod.	ADC	Total Power Consumption
0	B-Mode	ON (LNA PD=LO) 280 mW	ON (DVGA PD=LO) 230 mW	OFF 24 mW	ON 350 mW	884 mW
	—	POWER DOWN (LNA PD=HI) 12 mW	POWER DOWN (DVGA PD=HI) 14 mW		SLEEP MODE* 40 mW	N/A
1	CW Doppler Mode	ON (LNA PD=LO) 280 mW	POWER DOWN 14mW	ON 1.3W	40 mW	1.63W
	—	POWER DOWN (LNA PD=HI) 12 mW				N/A

* ADC in Sleep Mode using SPI™ compatible register 00h[1]. See SPI™ compatible Register Map.

The ADC within the LM96511 operates normally at ultra-low power levels. In addition, several power management modes are provided:

- Power Down (Accessible through PD bit of Top Control Register, 00h[0], or through individual channel power down, 01h[0-7]. See SPI™ compatible Register Map)
- Sleep (Accessible through SLEEP bit of Top Control Register 00h[1]. See SPI™ compatible Register Map)

Power Down is the lowest power consumption mode, but with a longer wake-up time than Sleep mode. In power down mode, all circuits in the ADC chip are turned off, including the PLL, reference and bias circuits.

The LM96511 ADC Power consumption in Sleep mode is higher than in Power Down mode, but pin access (ADC CW/DVGA pin) and fast wake-up enables duty cycle powering of the ADC.

The LM96511 ADC also allows channel by channel Power Down through the ADC/ LVDS Channel Power Down register (SPI™ register 01h[0-7]). When a single channel is in Power Down, the $\Sigma\Delta$ modulator, digital decimating filter and LVDS outputs for that channel will be shut off, with the corresponding single channel reduction in power consumption.

POWER-UP SEQUENCING

The ADC within the LM96511 should be powered-up prior to the amplifier section. The ADC contains a power-on reset circuit,

connected to ADC AVDD. To ensure correct reset operation, the power supplies should be provided in the following order (10 ms minimum delay between each supply):

1. ADC IO DVDD (connected to AMP IO DVDD) (1.2V)
2. ADC DVDD (1.2V)
3. ADC AVDD (1.2V)
4. The remaining supplies simultaneously or in any order: AMP AVCC A (3.3V), CW AVCC (5V), AMP DVDD (3.3V)

Additionally, it is required that the rise time for ADC DVDD and ADC AVDD each is longer than 40 μ s.

If the ADC power-up sequence order above (steps 1-3) is not followed, then, prior to amplifier power-up (step 4), the user should apply a 10ms duration reset via the reset pin ($\overline{ADC\ RST}$), and wait another 10ms before applying the amplifier power (step 4).

One method of power sequencing is to use the LM3881, or equivalent, Power Sequencer IC. When used with on-board regulators with shutdown capability (e.g. LP3878), the LM3881 can provide a simple, cost-effective way of controlling the sequence of 3 supplies.

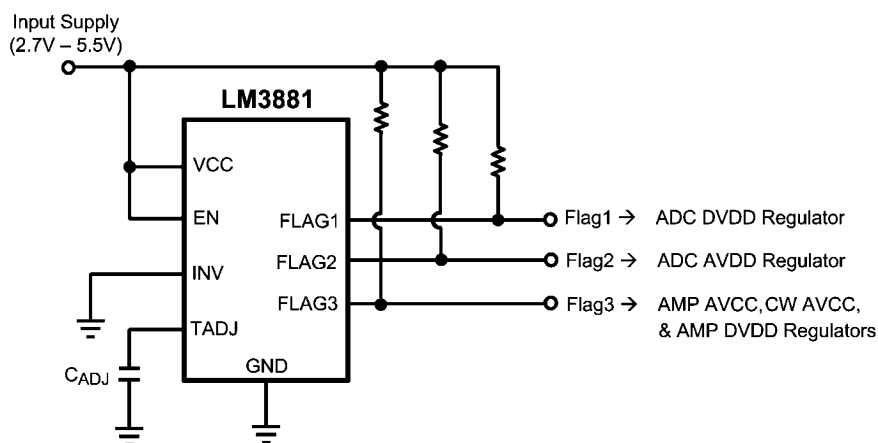

30087055

FIGURE 39. LM3881 Power Sequencer Can be Used for Proper LM96511 Power-Up

LM3881's "Flag1" output is the first to come-up and "Flag3" is the last. For the LM96511, the ADC IO DVDD regulator will be the first to come-up and thus need not be controlled by the LM3881. ADC DVDD will be controlled by the LM3881 "Flag1"

output, ADC AVDD by "Flag2" output, and "Flag3" powers-up the rest of the supplies simultaneously.

To power down, turn off the voltages in the exact reverse order.

Recommended Operating Conditions

IOR	On (SPI™ Register 02h[4]= 1)
ADC Sampling Rate	40/45 MSPS (SPI™ Register 00h[4]=1)
DVGA Initial Attenuation (See Table 5)	32dB (DVGA INIT MSB = HI, DVGA INIT LSB = HI)
DVGA PA HI	LO
ADC Data Out	LVDS
Equalizer	Off (SPI™ Register 0Bh[4]=0) (Default)
CGS	Auto Gain (SPI™ Register 0Ah[7]= 0) (Default)
SHBW (PLL Bandwidth)	Low Bandwidth (SPI™ Register 03h[1]= 0) (Default)
DVGA Half-Step Disable	0 (SPI™ Register 1Ah[3]= 0) (Default)
All Other Conditions	Default

SPI™ Interface

THE SERIAL PERIPHERAL INTERFACE

The LM96511 provides several user controlled functions which are accessed through a standard SPI™ compatible, Serial Interface. Figure 40 illustrates a method to convert a “four wire” SPI™ compatible controller (Data Out, Data

In, Clock, and Chip Select) to the “three-wire” (bi-directional Data In / Out) SPI™ compatible interface required by LM96511. The Serial Interface offers users with a range of supply voltages from 1.2V to 1.8V. The Level Translator shown allows the SPI™ Controller to Write to or Read from the LM96511 even if it uses a different supply voltage than LM96511.

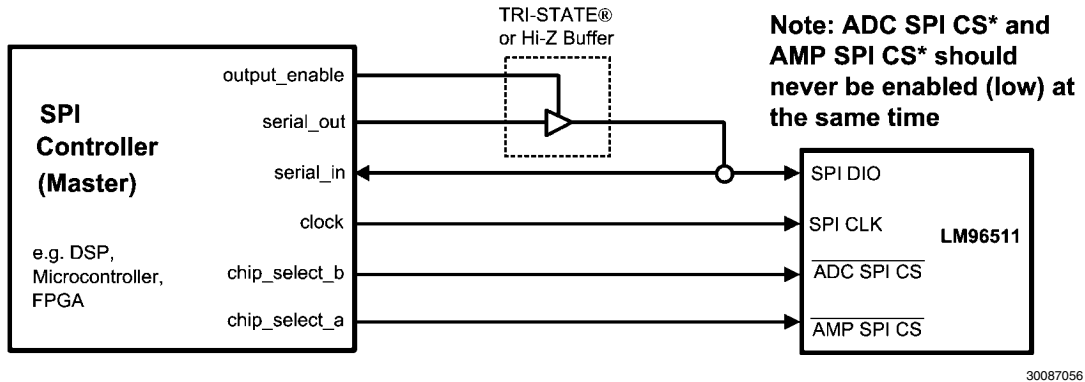

FIGURE 40. SPI™ Bus Master Slave Connection

ACCESS TO THE SERIAL PERIPHERAL INTERFACE

The SPI™ compatible interface is accessed through the use of four pins: $\overline{\text{ADC SPI}}^{\text{TM}} \text{CS}$, $\overline{\text{AMP SPI}}^{\text{TM}} \text{CS}$, SPI™ DIO, and SPI™ CLK. The SPI™ DIO is the data input/ output bidirectional port. The SPI™ DIO voltage levels are between the SPI™ supply voltage and ground. The SPI™ CLK acts as the SPI™ compatible clock input. Two chip selects are used to access the two functional parts of the device, $\overline{\text{ADC SPI}}^{\text{TM}} \text{CS}$ for the ADC segment and $\overline{\text{AMP SPI}}^{\text{TM}} \text{CS}$ for the amplifier segment. The generic timing diagram in Figure 41 shows the relative timing of the signals used to access the Serial Interface. Figure 8 and Figure 9 are included to give timing specifics for write mode and read mode respectively. Values for these specific parameters can be found in the Digital Input and Output Characteristics section of the datasheet.

The initial conditions for the SPI™ compatible signals are the beginning of an access sequence as follows: SPI™ CLK will start low, both $\overline{\text{AMP SPI}}^{\text{TM}} \text{CS}$ and $\overline{\text{ADC SPI}}^{\text{TM}} \text{CS}$ will start high, and SPI™ DIO will be undriven. To start an SPI™ access, either $\overline{\text{AMP SPI}}^{\text{TM}} \text{CS}$ or $\overline{\text{ADC SPI}}^{\text{TM}} \text{CS}$ (never both at the same time) will be brought low. At the same time, SPI™ DIO should be driven to the MSB of the address to be accessed. The SPI™ CLK will then start and rise in the center of the address bits from MSB to LSB. Each address is represented with 7 bits, A[7:1], the first 7 bits of the sequence on

SPI™ DIO. The eighth bit in the SPI™ DIO sequence, A[0] denotes a read or write access command, R/W. If the access is a read access, R/W = 1, then the user must disable the master line driven on the next falling edge of SPI™ CLK. At this point, the line will be driven by the SPI™ compatible interface of the LM96511 (slave). As the SPI™ CLK continues to toggle, the SPI™ slave will drive out the bits associated with the address input to the part D[7:0]. After the eight bits have been shifted out, the chip select can be returned high. If the access is a write access, R/W = 0, the user must drive the 8 bits associated with the address given, D[7:0], on the next eight SPI™ compatible clock cycles. After these 8 bits are shifted in, the chip select can return to the high state ending the transaction. If multiple transactions are done on a single SPI™, the associated chip select must be returned high between successive commands. During a write command, if the chip select signal is pulled high prior to the appropriate time, the write access will not be completed and the internal SPI™ compatible interface may not properly clear. At this point, a hard reset may be necessary to overcome a bad state, and writing may need to recommence. Two reset pins are also available on the LM96511, AMP RST (active HI) and $\overline{\text{ADC RST}}$ (active LO). These reset pins will asynchronously clear the AMP SPI™ and ADC SPI™ respectively.

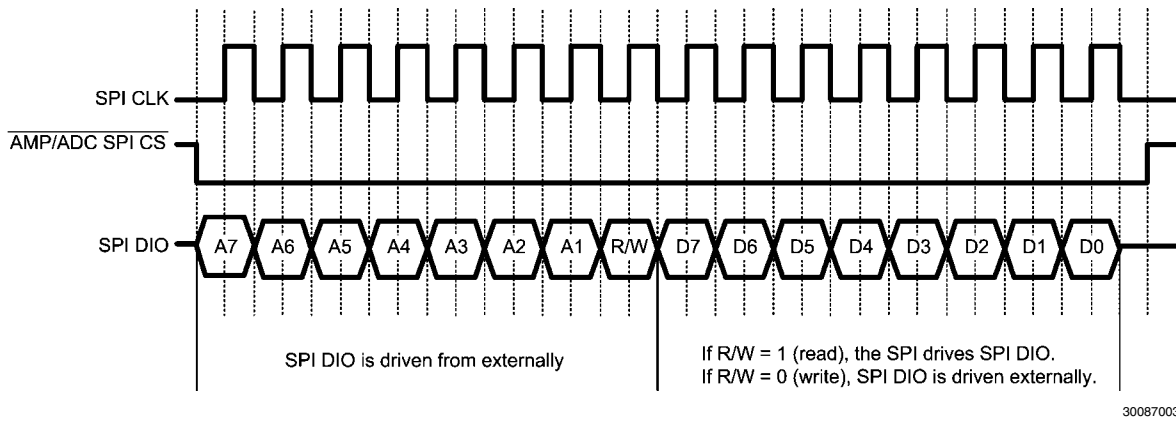

FIGURE 41. SPI™ Compatible Read/Write Timing Diagram

CONNECTING MULTIPLE LM96511 DEVICES TOGETHER

In certain applications, more than one LM96511 may need to be accessed by the same SPI™ compatible master controller. In this case, separate chip selects will be required for each AMP SPI™ CS pin in the system. This is due to the fact that each amplifier path will have path specific information which will need to be relayed to the paths individually. The $\overline{\text{ADC}}$ SPI™ CS can typically be shared as the ADC channels have very few channel specific programming requirements. An ex-

ception may be made in the case of a user who would choose to power down certain ADC's in the system (done through ADC SPI™ register), in which case separate lines would be needed for each . A shared $\overline{\text{ADC}}$ SPI™ CS system is shown in *Figure 42*. The user must realize that connecting the chip selects of numerous chips in any system will negate the use of read mode for the affected SPI™ slaves. This is due to bus contention issues as each slave will attempt to drive its value at that address.

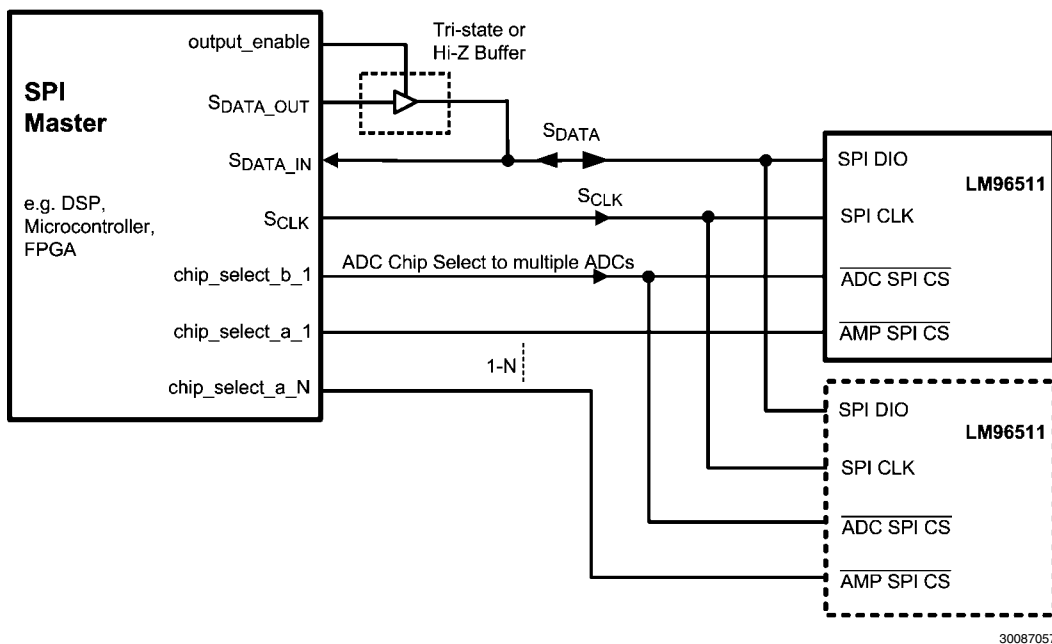

FIGURE 42. SPI™ Compatible Interconnect for Multiple LM96511's (Open Drain Mode)

SERIAL PERIPHERAL INTERFACE READ AND WRITE SPEED

SPI™ CLK controls the speed of interaction with the LM96511. See the Digital Input and Output Characteristics (under "SPI™") section of the datasheet for the timing information.

The following table shows the complete set of user accessible SPI™ compatible registers, with descriptions of the functionality of each bit in the following section.

SPI™ Register Map

- The “Address” column corresponds to A7-A1 (MSB –LSB).
- A0, which is the R/W bit, is not considered as part of the address.
- “RSV” = Reserved (See notes if applicable.)

Register Index — ADC Section (Enabled with ADC SPI™ CS):									
Addr	b[7]	b[6]	b[5]	b[4]	b[3]	b[2]	b[1]	b[0]	Default
ADC Top Control Register (Note 1)									
00h	0	0	CBR	40/50	SRES	0	SLEEP	PD	00h
ADC / LVDS Channel Power Down Register (Note 2)									
01h	PD7	PD6	PD5	PD4	PD3	PD2	PD1	PD0	00h
Modulator Overload Control Register (Note 3)									
02h	0	0	0	IOR	0	0	0	0	00h
PLL Control Register (Note 4)									
03h	0	0	0	0	0	0	SHBW	STCAL	00h
LVDS Input Clock Hysteresis (Note 5)									
05h	0	0	INVCLK	100HYS	50HYS	20HYS	10HYSOFF F	HYSOFF	00h
Serializer Custom Pattern 0 Register (Note 6)									
08h	Custom Pattern[7]	Custom Pattern[6]	Custom Pattern[5]	Custom Pattern [4]	Custom Pattern [3]	Custom Pattern [2]	Custom Pattern[1]	Custom Pattern[0]	00h
Serializer Custom Pattern 1 Register (Note 6)									
09h	0	0	0	0	Custom Pattern [11]	Custom Pattern [10]	Custom Pattern[9]	Custom Pattern[8]	00h
Decimator Clipping Control Register (Note 7)									
				DGFa			DGFb		
0Ah	CGS	0	a[2]	a[1]	a[0]	b[2]	b[1]	b[0]	00h
Decimator Control Register (Note 8)									
0Bh	0	0	0	EQON	DFS	MSB	TSEL[1]	TSEL[0]	00h
LVDS Control Register (Note 9)									
0Ch		0	0	TX_term	I_drive [1]	I_drive[0]	OCM	SLVS	00h
ADC Die ID (Read Only)									
0Fh		RSV	RSV	RSV	RSV	RSV	RSV	RSV	N/A

Register Index— Amplifier Section (Enabled with AMP SPI™ CS):									
Doppler Controls (Note 10)									
11h	0	0	0	0	CH0 PH[3]	CH0 PH[2]	CH0 PH[1]	CH0 PH[0]	00h
12h	0	0	0	0	CH1 PH[3]	CH1 PH[2]	CH1 PH[1]	CH1 PH[0]	00h
13h	0	0	0	0	CH2 PH[3]	CH2 PH[2]	CH2 PH[1]	CH2 PH[0]	00h
14h	0	0	0	0	CH3 PH[3]	CH3 PH[2]	CH3 PH[1]	CH3 PH[0]	00h
15h	0	0	0	0	CH4 PH[3]	CH4 PH[2]	CH4 PH[1]	CH4 PH[0]	00h
16h	0	0	0	0	CH5 PH[3]	CH5 PH[2]	CH5 PH[1]	CH5 PH[0]	00h
17h	0	0	0	0	CH6 PH[3]	CH6 PH[2]	CH6 PH[1]	CH6 PH[0]	00h

Register Index— Amplifier Section (Enabled with AMP SPI™ CS):									
18h	0	0	0	0	CH7 PH[3]	CH7 PH[2]	CH7 PH[1]	CH7 PH[0]	00h
Individual CW Doppler Channel Phase Update Register (Note 11)									
19h	CS7	CS6	CS5	CS4	CS3	CS2	CS1	CS0	00h
DVGA Attenuation Control Register (Note 12)									
1Ah	0	0	0	0	Half Step Disable (0=0.05 db; 1=0.1db)	R_EN	R1	R0	00h
LNA Offset Trim (Note 13)									
1Bh	LNA Ch0 Polarity	LNA Ch0 D6 (MSB)	LNA Ch0 D5	LNA Ch0 D4	LNA Ch0 D3	LNA Ch0 D2	LNA Ch0 D1	LNA Ch0 D0 (LSB)	Factory Set
1Ch	LNA Ch1 Polarity	LNA Ch1 D6 (MSB)	LNA Ch1 D5	LNA Ch1 D4	LNA Ch1 D3	LNA Ch1 D2	LNA Ch1 D1	LNA Ch1 D0 (LSB)	Factory Set
1Dh	LNA Ch2 Polarity	LNA Ch2 D6 (MSB)	LNA Ch2 D5	LNA Ch2 D4	LNA Ch2 D3	LNA Ch2 D2	LNA Ch2 D1	LNA Ch2 D0 (LSB)	Factory Set
1Eh	LNA Ch3 Polarity	LNA Ch3 D6 (MSB)	LNA Ch3 D5	LNA Ch3 D4	LNA Ch3 D3	LNA Ch3 D2	LNA Ch3 D1	LNA Ch3 D0 (LSB)	Factory Set
1Fh	LNA Ch4 Polarity	LNA Ch4 D6 (MSB)	LNA Ch4 D5	LNA Ch4 D4	LNA Ch4 D3	LNA Ch4 D2	LNA Ch4 D1	LNA Ch4 D0 (LSB)	Factory Set
20h	LNA Ch5 Polarity	LNA Ch5 D6 (MSB)	LNA Ch5 D5	LNA Ch5 D4	LNA Ch5 D3	LNA Ch5 D2	LNA Ch5 D1	LNA Ch5 D0 (LSB)	Factory Set
21h	LNA Ch6 Polarity	LNA Ch6 D6 (MSB)	LNA Ch6 D5	LNA Ch6 D4	LNA Ch6 D3	LNA Ch6 D2	LNA Ch6 D1	LNA Ch6 D0 (LSB)	Factory Set
22h	LNA Ch7 Polarity	LNA Ch7 D6 (MSB)	LNA Ch7 D5	LNA Ch7 D4	LNA Ch7 D3	LNA Ch7 D2	LNA Ch7 D1	LNA Ch7 D0 (LSB)	Factory Set
Post Amp (PA) Offset Trim (Note 13)									
23h	0	0	0	PA Ch0 Polarity	PA Ch0 D3 (MSB)	PA Ch0 D2	PA Ch0 D1	PA Ch0 D3 (LSB)	Factory Set
24h	0	0	0	PA Ch1 Polarity	PA Ch1 D3 (MSB)	PA Ch1 D2	PA Ch1 D1	PA Ch1 D3 (LSB)	Factory Set
25h	0	0	0	PA Ch2 Polarity	PA Ch2 D3 (MSB)	PA Ch2 D2	PA Ch2 D1	PA Ch2 D3 (LSB)	Factory Set
26h	0	0	0	PA Ch3 Polarity	PA Ch3 D3 (MSB)	PA Ch3 D2	PA Ch3 D1	PA Ch3 D3 (LSB)	Factory Set
27h	0	0	0	PA Ch4 Polarity	PA Ch4 D3 (MSB)	PA Ch4 D2	PA Ch4 D1	PA Ch4 D3 (LSB)	Factory Set
28h	0	0	0	PA Ch5 Polarity	PA Ch5 D3 (MSB)	PA Ch5 D2	PA Ch5 D1	PA Ch5 D3 (LSB)	Factory Set
29h	0	0	0	PA Ch6 Polarity	PA Ch6 D3 (MSB)	PA Ch6 D2	PA Ch6 D1	PA Ch6 D3 (LSB)	Factory Set
2Ah	0	0	0	PA Ch7 Polarity	PA Ch7 D3 (MSB)	PA Ch7 D2	PA Ch7 D1	PA Ch7 D3 (LSB)	Factory Set
Reserved Registers (RSV)									

Register Index— Amplifier Section (Enabled with AMP SPI™ CS):									
2Bh	RSV	RSV	RSV	RSV	RSV	RSV	RSV	RSV	N/A
2Ch	RSV	RSV	RSV	RSV	RSV	RSV	RSV	RSV	N/A
2Dh	RSV	RSV	RSV	RSV	RSV	RSV	RSV	RSV	N/A
2Eh	RSV	RSV	RSV	RSV	RSV	RSV	RSV	RSV	N/A
2Fh	RSV	RSV	RSV	RSV	RSV	RSV	RSV	RSV	N/A
Chip ID (Read Only)									
30h	Id[7]	Id[6]	Id[5]	Id[4]	Id[3]	Id[2]	Id[1]	Id[0]	N/A

SPI™ Register Map Notes

1. ADC Top Control Register

The Top Control Register is the basic initialization and control register for the LM96511 ADC.

Bit	Description
7:6	Write 0
5	CBR: Control Bus Read. When asserted register 00h (this register) can be read, but no other registers. When de-asserted all other registers can be read, but not register 00h. 0: Register 00h cannot be read using SPI™ Read. All other registers can be read back. 1: Register 00h can be read using SPI™ Read. All other registers cannot be read back.
4	40/50: Selects the ADC sample rate. This bit should be set according to the applied input clock to obtain optimal performance. 0: 45-50MSPS 1: 40-45MSPS
3	SRES: Software Reset. When asserted the software reset will reset the LM96511 ADC device. SRES performs the same function as the hardware reset ($\overline{\text{ADC RST}}$ pin). The SRES is self clearing in approximately 2 μs . 0: Software Reset Inactive 1: Software Reset Active
2	0
1	SLEEP: Sleep Mode. Powers down the device with the exception of the PLL and the reference blocks. The time to wake-up from sleep mode is < 10 μs . 0: Sleep Mode Inactive 1: Sleep Mode Active
0	PD: Power Down Mode. Completely powers down the device. The power up time is approximately 20 ms. 0: PD Mode Inactive, device operates normally 1: PD Mode Active, device powered down

2. ADC/LVDS Channel Power Down Register

The ADC/ LVDS Channel Power Down Mode Register provides the capability to independently put each ADC channel in Power Down mode.

Bit	Description
7	PD7: Channel 7 Power Down 0: Channel Active 1: Channel Power Down
6	PD6: Channel 6 Power Down 0: Channel Active 1: Channel Power Down
5	PD5: Channel 5 Power Down 0: Channel Active 1: Channel Power Down
4	PD4: Channel 4 Power Down 0: Channel Active 1: Channel Power Down

Bit	Description
3	PD3: Channel 3 Power Down 0: Channel Active 1: Channel Power Down
2	PD2: Channel 2 Power Down 0: Channel Active 1: Channel Power Down
1	PD1: Channel 1 Power Down 0: Channel Active 1: Channel Power Down
0	PD0: Channel 0 Power Down 0: Channel Active 1: Channel Power Down

3. Modulator Overload Control Register

Bit	Description
7:5	Write 0
4	IOR: Enable IOR On Mode (Instand Overload Recovery) This bit can be used to quickly enable IOR mode with the default IOR settings for DGF (see register 0Ah). 0: IOR Mode Disabled 1: IOF Mode Enabled
3:0	Write 0

4. PLL Control Register

Bit	Description
7:2	Write 0
4	SHBW: Set PLL to High Bandwidth. The selection of the PLL bandwidth permits to set the sensitivity of the PLL to input clock jitter. Less bandwidth decreases the sensitivity to input clock jitter. The PLL Bandwidth is related to the sampling frequency, the exact values of which can be found in the electrical specifications table. The PLL will pass any input clock jitter up to the PLL bandwidth, while jitter above the PLL bandwidth will be attenuated. Low bandwidth mode should be used for high jitter input clocks, while high bandwidth mode can be used for high-quality, low jitter input clocks. 0: PLL bandwidth is set to Low Bandwidth (400 kHz). 1: PLL bandwidth is set to High Bandwidth (1.4 MHz).
0	STCAL: Start VCO calibration. The calibration can be manually started in order to assure that the frequency tuning margin is maximum, for example, in case of large temperature change during operation it can be useful to restart the calibration. 0: The VCO calibration starts automatically if a Loss of Lock is detected. 1: The VCO calibration is restarted.

5. LVDS Input Clock - Hysteresis

Affects ADC CLK input hysteresis level.

Bit	Description
7:6	Write 0
5	INVCLK: Invert Input Reference Clock. This bit is used to invert the input clock. 0: Reference input clock not inverted. 1: Reference input clock inverted.
4	100HYS: Enable 100 mV hysteresis. This bit enables 100 mV hysteresis. It should be used for a CMOS input clock only. 0: Normal operation (10 mV hysteresis). 1: 100 mV hysteresis (CMOS input clock only)
3	50HYS: Enable 50 mV hysteresis. This bit enables 50 mV hysteresis. It should be used for a CMOS input clock only. 0: Normal operation (10 mV hysteresis). 1: 50 mV hysteresis (CMOS input clock only)

Bit	Description
2	20HYS: Enable 50 mV hysteresis. This bit enables 20 mV hysteresis. It should be used for a CMOS input clock only. 0: Normal operation (10 mV hysteresis). 1: 20 mV hysteresis (CMOS input clock only)
1	10HYSOFF: Disable 10 mV hysteresis. 10 mV hysteresis is the default setting. This bit is used to disable 10 mV hysteresis, in the case where another hysteresis setting is desired, for example when using a CMOS input clock. 0: 10 mV hysteresis. (LVDS Input clock only). 1: 10 mV hysteresis disabled.
0	HYSOFF: Disable all hysteresis settings This bit is used to disable all hysteresis settings. 0: Normal operation (10 mV hysteresis). 1: All hysteresis settings disabled.

6. Serializer Custom Pattern 0 and 1 Registers

Address: 08h (pattern 0):

This register in conjunction with register 09h provides storage for the custom de-skew pattern. See register 0Bh for a description of how this training sequence is used.

Bit	Description
7:0	Custom Pattern [7:0]. This pattern forms the lower byte of Custom Pattern [11:0] which is output by the serializer when the Training Sequence Select bits (bits 1:0) of the Decimator Control Register are set to select Training sequence 3.

Address: 09h (pattern 1):

This register in conjunction with User Register 08h provides storage for the custom de-skew pattern. See register 0Bh for a description of how this training sequence is used.

Bit	Description
7:4	Write 0
3:0	Custom Pattern [11:8]. This pattern forms the upper 4 bits of Custom Pattern [11:0] which is output by the serializer when the Training Sequence Select bits (bits 1:0) of the Decimator Control Register are set to select Training sequence 3.

7. Decimator Clipping Control Register

Bit	Description
7	<p>CGS: Custom Gain Setting. This bit is used to override the automatic gain settings for ADC and IOR modes. If the user wishes to write a custom digital gain coefficient using a[2:0] and b[2:0] of this register, then the CGS bit must be set.</p> <p>0: Normal operation Automatic gain settings used 1: Custom Gain Setting Gain setting from a[2:0] and b[2:0] used</p>
6	Write 0
5:3	<p>a[2:0]: Digital Gain Coefficient. In IOR on mode, the input range of an ADC channel is limited to 3.12 Vpp. In IOR off mode the input range is 4.20 Vpp. The output of the digital filter has to be scaled according to the selected mode (the filter data has to be mapped in to the 12bit output data), the difference between 3.12 Vpp and 4.20 Vpp is -2.6 dB, hence the digital filter gain has to be set to 2.6 dB when in IOR on mode and to 0dB when in IOR off mode (default mode). This is performed by setting a Digital Gain Factor (DGF) which is calculated using the following formula:</p> $DGF = \frac{32 + 4 \times DGFa + DGFb}{26}$ <p>The mapping of the coefficient values for a[2:0] is as follows: 011 = Not used. Defaults to 2 010 = 2 001 = 1 000 = 0 111 = -1 110 = -2 101 = Not used. Defaults to -2 100 = Not used. Defaults to -2 The mapping of the coefficient values for b[2:0] is shown below. Table 3 shows the available Digital Gain Coefficient settings.</p>
2:0	<p>The mapping of the coefficient values for b[2:0] is as follows: 011 = Not used. Defaults to 2 010 = 2 001 = 1 000 = 0 111 = -1 110 = -2 101 = Not used. Defaults to -2 100 = Not used. Defaults to -2</p>

TABLE 3. DGF To Digital Gain Look-Up Table

Coefficient a[2:0]	Coefficient b[2:0]	Digital Gain (dB)	Equivalent ADC Full Scale Input Range (Vpp)	
010	010	4.16	2.60	
010	001	3.95	2.66	
010	000	3.74	2.74	
010	111	3.52	2.80	
010	110	3.29	2.88	
001	001	3.06	2.96	
001	000	2.82	3.04	
001	111	2.58	3.12	IOR ON Mode Default Setting
001	110	2.33	3.22	
000	001	2.07	3.3	
000	000	1.80	3.42	
000	111	1.53	3.52	
000	110	1.24	3.64	
111	001	0.95	3.96	
111	000	0.64	3.90	
111	111	0.33	4.04	
111	110	0	4.20	IOR Off Mode Default Setting
110	001	-0.34	4.32	
110	000	-0.70	4.56	
110	111	-1.07	4.76	
110	110	-1.45	4.96	

8. Decimator Control Register

Bit	Description
7:5	Write 0
4	EQON: Equalizer Enable. This bit is used to enable or disable the digital equalizer. The equalizer can be switched on in order to reduce the group delay of the output data, at the cost of increased power. 0: Equalizer Disabled 1: Equalizer Enabled
3	DFS: Data Format Select. Selects the format, either Offset Binary or Twos Complement of the output data. 0: 2s Complement 1: Offset Binary
2	MSB: Select the bit order of the LVDS output data stream. 0: LSB first 1: MSB first
1:0	TSEL[1:0]: Training Sequence Select. These bits select the LVDS output data. The default mode of operation is where the filter output data is serialized. In the remaining modes the selected training sequence is repeatedly output from the serializer this allows the receiving data capture circuitry to perform the de-skewing process. One of three known words can be selected, the first two words are hard-coded in the block, the third one, the custom pattern, is written into Registers 08h and 09h Serializer Custom Pattern Registers. Note: The outputs bit-clock and word-clock are not affected by the value of the Training Sequence Select bits. 00 ADC data[11:0] 01 Training Sequence 1: 000000111111 10 Training Sequence 2: 101010101010 11 Training Sequence 3: Custom Pattern

9. LVDS Control Register

Bit	Description
7:5	Write 0
4	TX_term: Enable Internal 100Ω termination for data outputs. 0: Internal 100Ω termination disabled. 1: Internal 100Ω termination enabled.
3:2	I_drive[1:0]: Controls the current drive of the data outputs. 00: 2.5 mA 01: 3.5 mA 10: Reserved 11: 5mA
1	OCM: Output Common mode. Allows the output common mode to be shifted depending on the setting of ADC IO DVDD. If bit 0 of this register, SLVS, is set to 1 then changing OCM will have no impact on the output common mode. The output common mode in SLVS mode is fixed, as described in the Electrical Specifications section of this datasheet. For ADC IO DVDD = 1.2V, OCM must be set to 0. For ADC IO DVDD = 1.8V, OCM must be set to 1. 0: Output Common Mode, VOVM = 1.0V 1: Output Common Mode, VOVM = 1.25V
0	SLVS: Select the format for output data, either LVDS or SLVS. The differences in timing and electrical specifications between the two modes can be seen in the Electrical Specifications section of the datasheet. If this bit is set to 1 (SLVS mode), OCM has no effect and the output common mode will be set for SLVS as described in the Electrical Specifications section of this datasheet. When LVDS mode is selected, the output common mode must be selected using the OCM bit of this register. 0: LVDS Mode 1: SLVS Mode

10. Doppler Controls:

Bit	Description
7:4	Write 0
3:0	Chx[3:0]: CW Doppler Channel "x" (0-7) phase angle in binary format from 0° (0000) to 360° (1111) in 22.5° increments.

11. Individual CW Doppler Channel Phase Update

The SPI™ compatible registers for the Doppler function (i.e. 11h-18h) are shadow registers that will only be loaded into an active working register on CW CLK+ rising edge after a CW/DVGA RST (pin K15) pulse (see [Figure 10](#)). This load action will also reset all counters in the CW Doppler mixer.

Upon initial chip power-up, CW Doppler register load and mixer counter reset occurs (see SPI™ Register Map for default values). SPI™ Read operation reads the value of the Shadow register (not the Active register). However, Shadow and Active register values should be the same assuming no Write operation after the previous CW/DVGA RST high state.

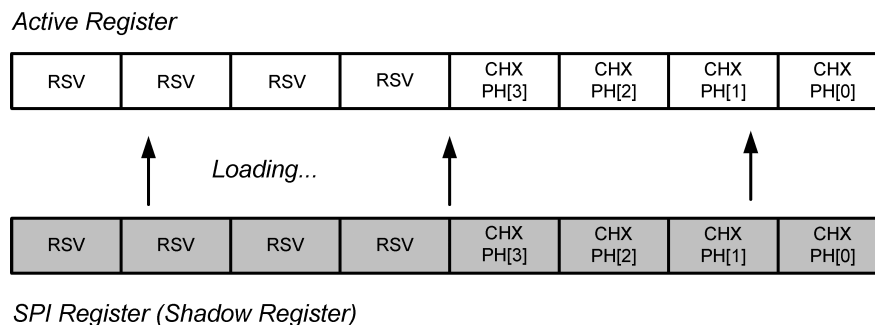

Figure 41. CW Doppler Shadow Register Representation

30087062

In addition to being able to load all CW Doppler channels 0-7 phase angles simultaneously, it is also possible to load each channel's phase angle individually using SPI™ address 19h. For example, to update phase angle for channel 5 and channel

6 only, the following data is written to 19h: 01100000. This way, Channel 5 and 6 Active register is updated with data in 16h and 17h but Active registers for the other 6 channels are left intact.

Bit	Description
7	CS7: This bit allows CW Doppler channel 7 phase angle to be updated to the value in shadow register 18h. 0: Active register for channel 7 left intact 1: Load active register for channel 7 with 18h data when CW/DVGA RST is pulled HI
6	CS6: This bit allows CW Doppler channel 6 phase angle to be updated to the value in shadow register 17h. 0: Active register for channel 6 left intact 1: Load active register for channel 6 with 17h data when CW/DVGA RST is pulled HI
5	CS5: This bit allows CW Doppler channel 5 phase angle to be updated to the value in shadow register 16h. 0: Active register for channel 5 left intact 1: Load active register for channel 5 with 16h data when CW/DVGA RST is pulled HI
4	CS4: This bit allows CW Doppler channel 4 phase angle to be updated to the value in shadow register 15h. 0: Active register for channel 4 left intact 1: Load active register for channel 4 with 15h data when CW/DVGA RST is pulled HI
3	CS3: This bit allows CW Doppler channel 3 phase angle to be updated to the value in shadow register 14h. 0: Active register for channel 3 left intact 1: Load active register for channel 3 with 14h data when CW/DVGA RST is pulled HI
2	CS2: This bit allows CW Doppler channel 2 phase angle to be updated to the value in shadow register 13h. 0: Active register for channel 2 left intact 1: Load active register for channel 2 with 13h data when CW/DVGA RST is pulled HI
1	CS1: This bit allows CW Doppler channel 1 phase angle to be updated to the value in shadow register 12h. 0: Active register for channel 1 left intact 1: Load active register for channel 1 with 12h data when CW/DVGA RST is pulled HI
0	CS0: This bit allows CW Doppler channel 0 phase angle to be updated to the value in shadow register 11h. 0: Active register for channel 0 left intact 1: Load active register for channel 0 with 11h data when CW/DVGA RST is pulled HI

12. DVGA Attenuation Control:

When the CW/DVGA RST pin is HIGH, the step attenuator block in the DVGA can be reset to one of five discrete selectable DVGA Initial Attenuations: 38, 36, 34, 32, or 0 dB. This DVGA Initial Attenuation can be set by either the SPI™ compatible register or by physically applying logic level voltages to ball pin A6 (DVGA INIT MSB), B5 (DVGA INIT LSB), and L17 (DVGA UP). See [Table 4](#). SPI™ address 1Ah[2:0] are the register bits used. Normal attenuator gain clocking can be resumed only after CW/DVGA RST pin is returned to 0.

TABLE 4. DVGA Initial Attenuation Truth Table

DVGA UP	E_EN	R1	R0	DVGA INIT MSB	DVGA INIT LSB	Attenuation with CW/DVGA RST pin High (dB)
L17 pin	1Ah[2]	1Ah[1]	1Ah[0]	A6 pin	B5 pin	
1	1	0	0	X	X	38
1	1	0	1	X	X	36
1	1	1	0	X	X	34
1	1	1	1	X	X	32
1	0	X	X	0	0	38
1	0	X	X	0	1	36
1	0	X	X	1	0	34
1	0	X	X	1	1	32
0	X	X	X	X	X	0

The following short-hand notation for the DVGA gain has been used:

TABLE 5. DVGA Notation

DVGA Gain (dB)	DVGA Attenuation (dB)	Short-hand Name
0	0	Max DVGA Gain
-19	19	Mid DVGA Gain
-38	38	Min DVGA Gain

13. LNA and PA Offset Trim Control Register:

There are 7 bits dedicated to LNA offset trim, plus the polarity bit. The maximum positive offset is 1111,1111 and the maximum negative offset is 0111,1111 with X000,0000 for minimum trim.

There are 4 bits dedicated to PA offset trim, plus the polarity bit. The maximum positive offset is 1,1111 and the maximum negative offset is 0,1111 with X,0000 for minimum trim.

The SPI™ compatible trim data operates through the same die fuses that are used for factory laser trim. The data written into a particular bit is influenced by whether the fuse related to that bit is blown at the factory or not. Here is what should be written to the SPI™ compatible bits for a particular “intended data”:

TABLE 6. Offset Trim “Write” Truth Table

Intended Data	Write Data	
	Factory Blown Fuse	Factory Un-Blown Fuse
0	1	0
1	0	1

To know whether a fuse is blown at the factory or not, the register should be read-back at power up (or after AMP RST pulse); a “1” indicates a blown fuse.

Here is an example, related to LNA offset trim, for easier understanding:

TABLE 7. Offset Trim “Write” and “Read” Example

SPI™ Read Back at Power-up or after AMP RST	0000 1100
<i>Intended Data</i>	0000 1010
SPI™ Write Data	0000 0110
SPI™ Read Data (after Write)	0000 1010

Physical Dimensions inches (millimeters) unless otherwise noted

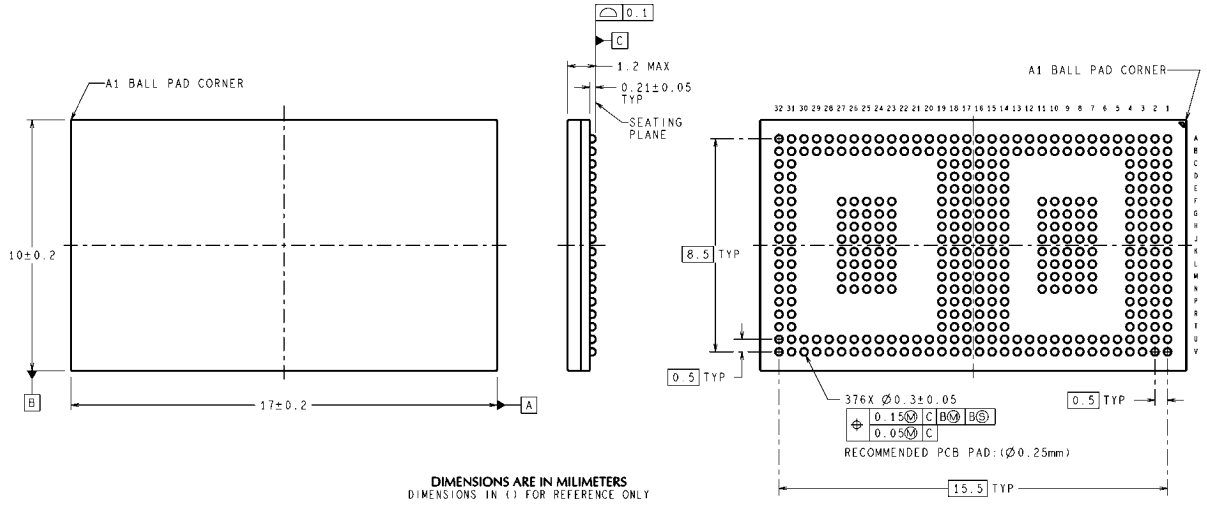

TBD

SLM376A (Rev A)

Notes

For more National Semiconductor product information and proven design tools, visit the following Web sites at:
www.national.com

Products		Design Support	
Amplifiers	www.national.com/amplifiers	WEBENCH® Tools	www.national.com/webench
Audio	www.national.com/audio	App Notes	www.national.com/appnotes
Clock and Timing	www.national.com/timing	Reference Designs	www.national.com/refdesigns
Data Converters	www.national.com/adc	Samples	www.national.com/samples
Interface	www.national.com/interface	Eval Boards	www.national.com/evalboards
LVDS	www.national.com/lvds	Packaging	www.national.com/packaging
Power Management	www.national.com/power	Green Compliance	www.national.com/quality/green
Switching Regulators	www.national.com/switchers	Distributors	www.national.com/contacts
LDOs	www.national.com/ldo	Quality and Reliability	www.national.com/quality
LED Lighting	www.national.com/led	Feedback/Support	www.national.com/feedback
Voltage References	www.national.com/vref	Design Made Easy	www.national.com/easy
PowerWise® Solutions	www.national.com/powerwise	Applications & Markets	www.national.com/solutions
Serial Digital Interface (SDI)	www.national.com/sdi	Mil/Aero	www.national.com/milaero
Temperature Sensors	www.national.com/tempensors	SolarMagic™	www.national.com/solarmagic
PLL/VCO	www.national.com/wireless	PowerWise® Design University	www.national.com/training

THE CONTENTS OF THIS DOCUMENT ARE PROVIDED IN CONNECTION WITH NATIONAL SEMICONDUCTOR CORPORATION ("NATIONAL") PRODUCTS. NATIONAL MAKES NO REPRESENTATIONS OR WARRANTIES WITH RESPECT TO THE ACCURACY OR COMPLETENESS OF THE CONTENTS OF THIS PUBLICATION AND RESERVES THE RIGHT TO MAKE CHANGES TO SPECIFICATIONS AND PRODUCT DESCRIPTIONS AT ANY TIME WITHOUT NOTICE. NO LICENSE, WHETHER EXPRESS, IMPLIED, ARISING BY ESTOPPEL OR OTHERWISE, TO ANY INTELLECTUAL PROPERTY RIGHTS IS GRANTED BY THIS DOCUMENT.

TESTING AND OTHER QUALITY CONTROLS ARE USED TO THE EXTENT NATIONAL DEEMS NECESSARY TO SUPPORT NATIONAL'S PRODUCT WARRANTY. EXCEPT WHERE MANDATED BY GOVERNMENT REQUIREMENTS, TESTING OF ALL PARAMETERS OF EACH PRODUCT IS NOT NECESSARILY PERFORMED. NATIONAL ASSUMES NO LIABILITY FOR APPLICATIONS ASSISTANCE OR BUYER PRODUCT DESIGN. BUYERS ARE RESPONSIBLE FOR THEIR PRODUCTS AND APPLICATIONS USING NATIONAL COMPONENTS. PRIOR TO USING OR DISTRIBUTING ANY PRODUCTS THAT INCLUDE NATIONAL COMPONENTS, BUYERS SHOULD PROVIDE ADEQUATE DESIGN, TESTING AND OPERATING SAFEGUARDS.

EXCEPT AS PROVIDED IN NATIONAL'S TERMS AND CONDITIONS OF SALE FOR SUCH PRODUCTS, NATIONAL ASSUMES NO LIABILITY WHATSOEVER, AND NATIONAL DISCLAIMS ANY EXPRESS OR IMPLIED WARRANTY RELATING TO THE SALE AND/OR USE OF NATIONAL PRODUCTS INCLUDING LIABILITY OR WARRANTIES RELATING TO FITNESS FOR A PARTICULAR PURPOSE, MERCHANTABILITY, OR INFRINGEMENT OF ANY PATENT, COPYRIGHT OR OTHER INTELLECTUAL PROPERTY RIGHT.

LIFE SUPPORT POLICY

NATIONAL'S PRODUCTS ARE NOT AUTHORIZED FOR USE AS CRITICAL COMPONENTS IN LIFE SUPPORT DEVICES OR SYSTEMS WITHOUT THE EXPRESS PRIOR WRITTEN APPROVAL OF THE CHIEF EXECUTIVE OFFICER AND GENERAL COUNSEL OF NATIONAL SEMICONDUCTOR CORPORATION. As used herein:

Life support devices or systems are devices which (a) are intended for surgical implant into the body, or (b) support or sustain life and whose failure to perform when properly used in accordance with instructions for use provided in the labeling can be reasonably expected to result in a significant injury to the user. A critical component is any component in a life support device or system whose failure to perform can be reasonably expected to cause the failure of the life support device or system or to affect its safety or effectiveness.

National Semiconductor and the National Semiconductor logo are registered trademarks of National Semiconductor Corporation. All other brand or product names may be trademarks or registered trademarks of their respective holders.

Copyright© 2011 National Semiconductor Corporation

For the most current product information visit us at www.national.com



**National Semiconductor
Americas Technical
Support Center**
Email: support@nsc.com
Tel: 1-800-272-9959

**National Semiconductor Europe
Technical Support Center**
Email: europe.support@nsc.com

**National Semiconductor Asia
Pacific Technical Support Center**
Email: ap.support@nsc.com

**National Semiconductor Japan
Technical Support Center**
Email: jpn.feedback@nsc.com

IMPORTANT NOTICE

Texas Instruments Incorporated and its subsidiaries (TI) reserve the right to make corrections, modifications, enhancements, improvements, and other changes to its products and services at any time and to discontinue any product or service without notice. Customers should obtain the latest relevant information before placing orders and should verify that such information is current and complete. All products are sold subject to TI's terms and conditions of sale supplied at the time of order acknowledgment.

TI warrants performance of its hardware products to the specifications applicable at the time of sale in accordance with TI's standard warranty. Testing and other quality control techniques are used to the extent TI deems necessary to support this warranty. Except where mandated by government requirements, testing of all parameters of each product is not necessarily performed.

TI assumes no liability for applications assistance or customer product design. Customers are responsible for their products and applications using TI components. To minimize the risks associated with customer products and applications, customers should provide adequate design and operating safeguards.

TI does not warrant or represent that any license, either express or implied, is granted under any TI patent right, copyright, mask work right, or other TI intellectual property right relating to any combination, machine, or process in which TI products or services are used. Information published by TI regarding third-party products or services does not constitute a license from TI to use such products or services or a warranty or endorsement thereof. Use of such information may require a license from a third party under the patents or other intellectual property of the third party, or a license from TI under the patents or other intellectual property of TI.

Reproduction of TI information in TI data books or data sheets is permissible only if reproduction is without alteration and is accompanied by all associated warranties, conditions, limitations, and notices. Reproduction of this information with alteration is an unfair and deceptive business practice. TI is not responsible or liable for such altered documentation. Information of third parties may be subject to additional restrictions.

Resale of TI products or services with statements different from or beyond the parameters stated by TI for that product or service voids all express and any implied warranties for the associated TI product or service and is an unfair and deceptive business practice. TI is not responsible or liable for any such statements.

TI products are not authorized for use in safety-critical applications (such as life support) where a failure of the TI product would reasonably be expected to cause severe personal injury or death, unless officers of the parties have executed an agreement specifically governing such use. Buyers represent that they have all necessary expertise in the safety and regulatory ramifications of their applications, and acknowledge and agree that they are solely responsible for all legal, regulatory and safety-related requirements concerning their products and any use of TI products in such safety-critical applications, notwithstanding any applications-related information or support that may be provided by TI. Further, Buyers must fully indemnify TI and its representatives against any damages arising out of the use of TI products in such safety-critical applications.

TI products are neither designed nor intended for use in military/aerospace applications or environments unless the TI products are specifically designated by TI as military-grade or "enhanced plastic." Only products designated by TI as military-grade meet military specifications. Buyers acknowledge and agree that any such use of TI products which TI has not designated as military-grade is solely at the Buyer's risk, and that they are solely responsible for compliance with all legal and regulatory requirements in connection with such use.

TI products are neither designed nor intended for use in automotive applications or environments unless the specific TI products are designated by TI as compliant with ISO/TS 16949 requirements. Buyers acknowledge and agree that, if they use any non-designated products in automotive applications, TI will not be responsible for any failure to meet such requirements.

Following are URLs where you can obtain information on other Texas Instruments products and application solutions:

Products

Audio	www.ti.com/audio
Amplifiers	amplifier.ti.com
Data Converters	dataconverter.ti.com
DLP® Products	www.dlp.com
DSP	dsp.ti.com
Clocks and Timers	www.ti.com/clocks
Interface	interface.ti.com
Logic	logic.ti.com
Power Mgmt	power.ti.com
Microcontrollers	microcontroller.ti.com
RFID	www.ti-rfid.com
OMAP Mobile Processors	www.ti.com/omap
Wireless Connectivity	www.ti.com/wirelessconnectivity

Applications

Communications and Telecom	www.ti.com/communications
Computers and Peripherals	www.ti.com/computers
Consumer Electronics	www.ti.com/consumer-apps
Energy and Lighting	www.ti.com/energy
Industrial	www.ti.com/industrial
Medical	www.ti.com/medical
Security	www.ti.com/security
Space, Avionics and Defense	www.ti.com/space-avionics-defense
Transportation and Automotive	www.ti.com/automotive
Video and Imaging	www.ti.com/video

TI E2E Community Home Page

e2e.ti.com

Mailing Address: Texas Instruments, Post Office Box 655303, Dallas, Texas 75265
Copyright © 2011, Texas Instruments Incorporated