

LP5524

AN-1702 LP5524 Evaluation Kit



Literature Number: SNVA284

Jumper Description

This describes the jumpers and the connectors on the LP5524 Evaluation Board.

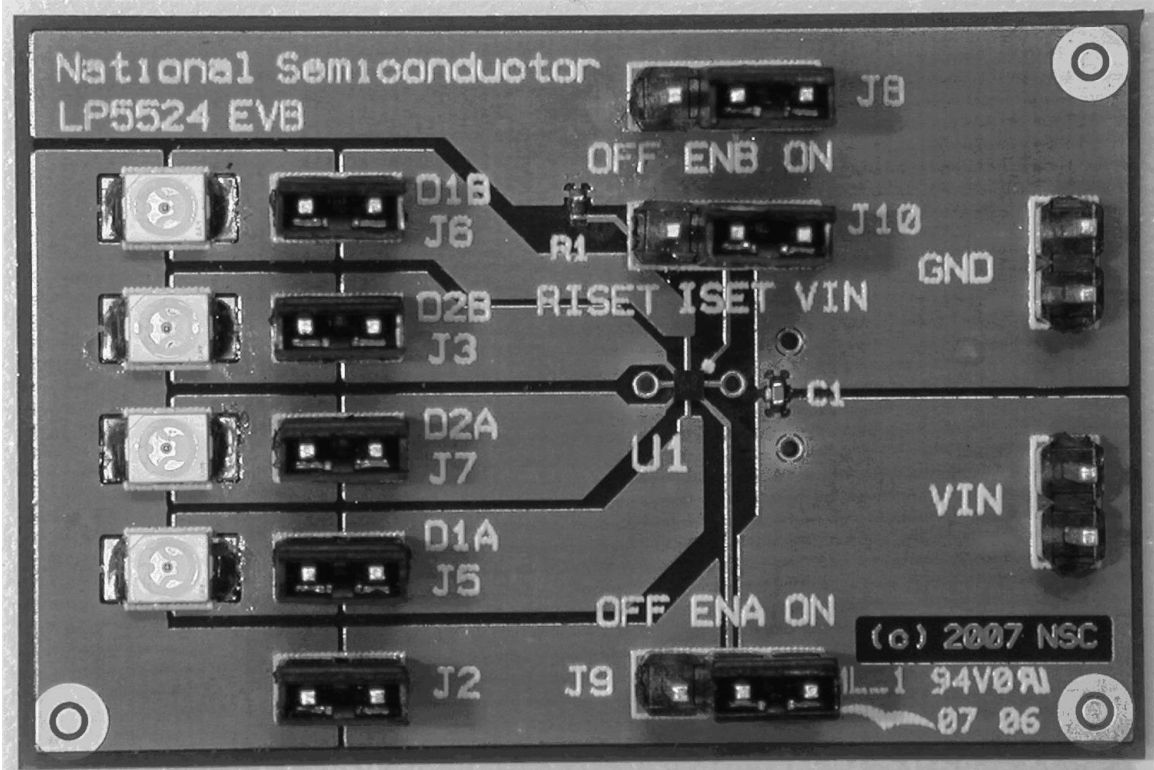

Figure 2. LP5524 Evaluation Board Top View

30035302

VIN – J1

This connector is the positive input for power supply. Evaluation board can operate with supply voltages from 2.7V to 5.5V. The input leads from power supply should be twisted and kept as short as possible. There is an input capacitor (C1) on board to smooth the input voltage.

GND – J4

This is the negative input for power supply.

J2

This jumper disconnects all LED cathodes from the GND. This can be used to separate the LED currents from the circuit current.

D1B – J6

This jumper can be used to disconnect the D1B output from the LED anode. This can be used to measure the D1B current.

D2B - J3

This jumper can be used to disconnect the D2B output from the LED anode. This can be used to measure the D2B current.

D2A – J7

This jumper can be used to disconnect the D2A output from the LED anode. This can be used to measure the D2A current.

D1A – J5

This jumper can be used to disconnect the D1A output from the LED anode. This can be used to measure the D1A current.

D2A – J7

This jumper can be used to disconnect the D2A output from the LED anode. This can be used to measure the D2A current.

ENB – J8

This is the ENB input. A three pin connector is applied to allow ENB to be connected either to VIN or to GND. The center pin is connected directly to ENB pin. This pin can be used to connect external PWM signal. Smaller than 300 Hz PWM frequency is recommended.

ISET – J10

ISET pin jumper. This can be used to connect the ISET pin either to VIN or to onboard R1SET resistor. Connecting ISET to VIN sets the LED current to default 5mA and connecting it to R1SET sets the current to 15.6mA. Center pin is connected directly to ISET pin and it can be used to connect external current set resistors.

ENA – J9

This is the ENA input. A three pin connector is applied to allow ENA to be connected either to VIN or to GND. The center pin is connected directly to ENA pin. This pin can be used to connect external PWM signal. Smaller than 300 Hz PWM frequency is recommended.

Getting Started

The following instructions show how to set up and use the LP5524 evaluation kit. Please use ESD protection to prevent any unwanted damaging ESD events.

1. Check the onboard jumpers. Jumpers on the LED outputs (J3, J5-J7) and the jumper from LED cathodes to gnd (J2) should be on. Remove jumpers from enables (J8 and J9). ISET can be connected either to VDD or RISET.
2. Connect evaluation board to a power supply. Check that operation voltage is between 2.7V to 5.5V.
3. Set the enable jumpers to ON position. ENA jumper enables drivers D1A and D2A and ENB jumper enables drivers D1B and D2B.
4. The Evaluation Kit is now ready to use.

Current Measurements

To measure the current of a single LED driver remove the jumper from that driver's output and connect current meter to jumper's pins. To measure the current of all LEDs remove the J2 jumper and connect current meter to J2 pins. To measure the current consumption of the device separate the LED ground current from the board's ground current by removing the J2 jumper and connecting the LED ground to power supply ground with separated wire. Then connect the current meter to evaluation board's ground wire. Figure 3 illustrates how to measure different currents.

PWM Dimming

To dim the LEDs feed a proper PWM signal to ENx pin. Less than 300 Hz PWM frequency is recommended. Ensure that PWM signals high and low levels are adequate.

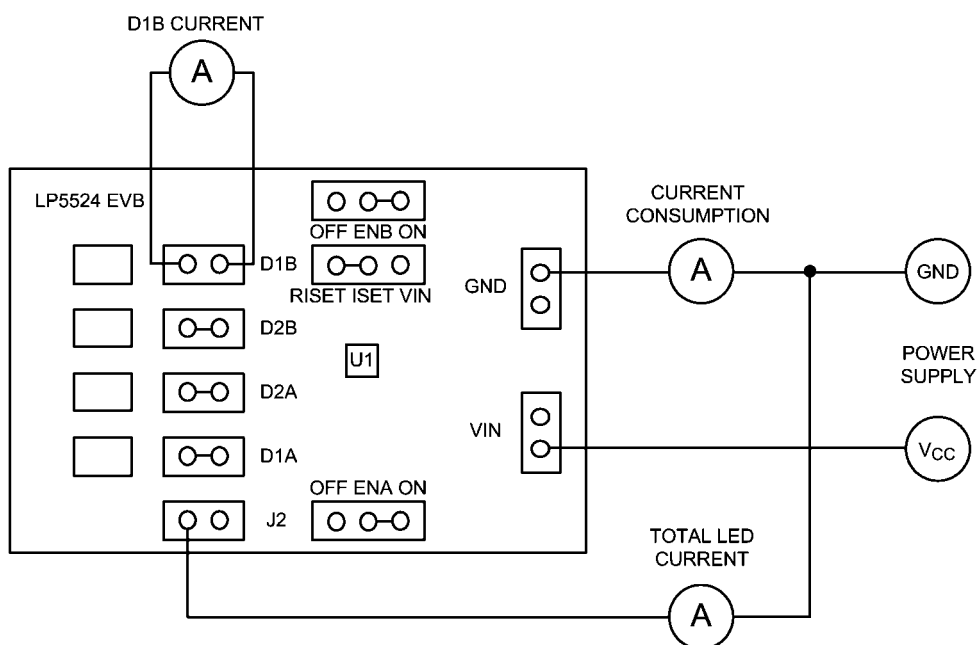

Figure 3. LP5524 Evaluation Board Current Measurements

30035305

Board Layout

A four layer board was used to enable the use of micro-VIAs. Micro VIA is required for routing the center pad of the LP5524. The evaluation board layers are:

1. Top, component side, signal
2. Layer 2, Vin plane (signal)
3. Layer 3, GND plane
4. Bottom, GND plane

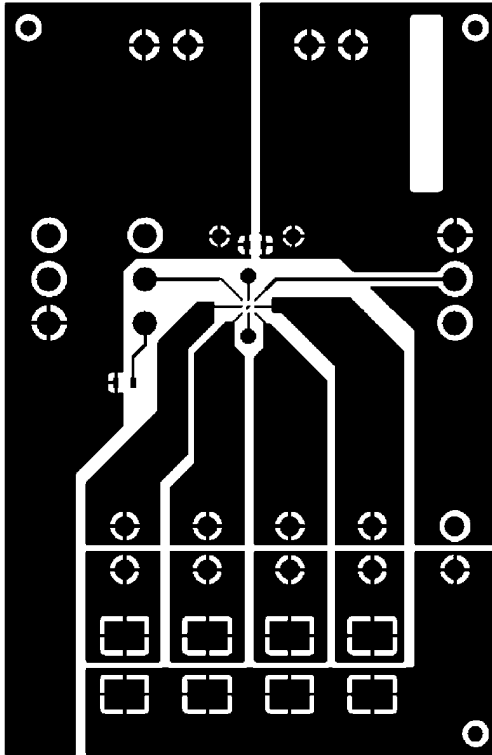

Figure 4. LP5524 Evaluation Board Layer 1 (Top). 30035310

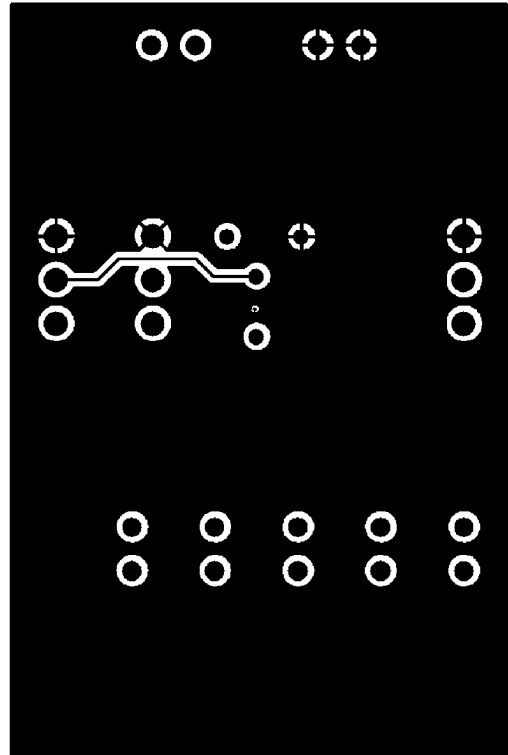

Figure 5. LP5524 Evaluation Board Layer 2. 30035311

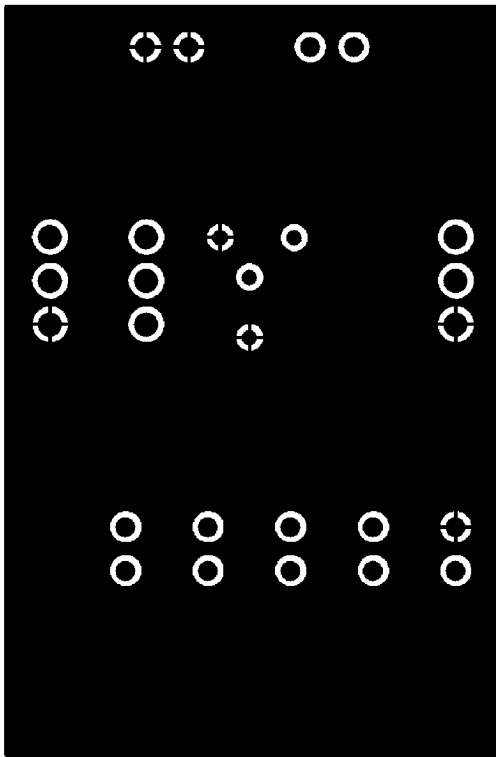

Figure 6. LP5524 Evaluation Board Layer 3. 30035303

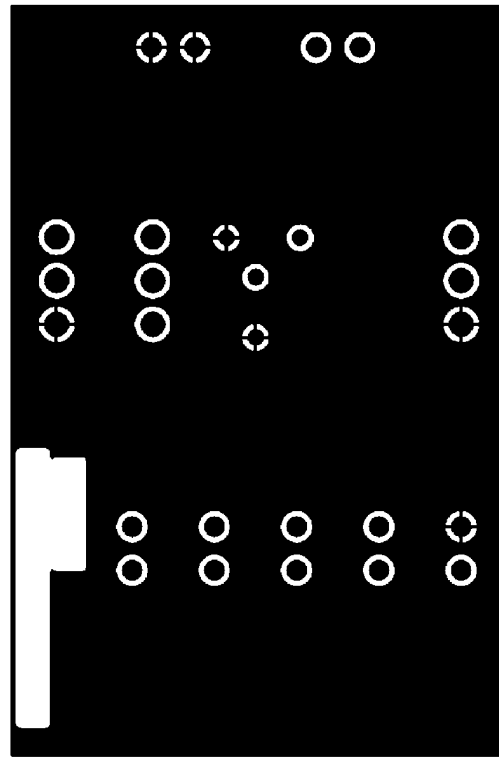

Figure 7. LP5524 Evaluation Board Layer 4 (Bottom). 30035304

Schematic

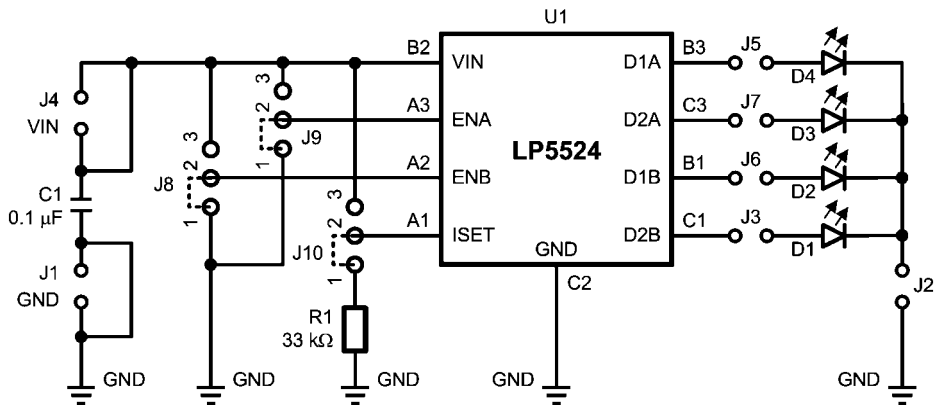

Figure 8. LP5524 Evaluation Board Schematic 30035312

List of Components

Reference	Model	Type	Vendor	Size
C1	100 nF 10V	Ceramic X5R	TDK	0402 (1005)
R1	33kΩ 1%	-	-	0402 (1005)
D1 -D4	LS T676	LED Red	Osram	3.0 mm x 3.4 mm x 2.1 mm
U1	LP5524	-	NSC	1.215 mm x 1.215 mm x 0.6 mm

Notes

For more National Semiconductor product information and proven design tools, visit the following Web sites at:

Products		Design Support	
Amplifiers	www.national.com/amplifiers	WEBENCH	www.national.com/webench
Audio	www.national.com/audio	Analog University	www.national.com/AU
Clock Conditioners	www.national.com/timing	App Notes	www.national.com/appnotes
Data Converters	www.national.com/adc	Distributors	www.national.com/contacts
Displays	www.national.com/displays	Green Compliance	www.national.com/quality/green
Ethernet	www.national.com/ethernet	Packaging	www.national.com/packaging
Interface	www.national.com/interface	Quality and Reliability	www.national.com/quality
LVDS	www.national.com/lvds	Reference Designs	www.national.com/refdesigns
Power Management	www.national.com/power	Feedback	www.national.com/feedback
Switching Regulators	www.national.com/switchers		
LDOs	www.national.com/lido		
LED Lighting	www.national.com/led		
PowerWise	www.national.com/powerwise		
Serial Digital Interface (SDI)	www.national.com/sdi		
Temperature Sensors	www.national.com/tempsensors		
Wireless (PLL/VCO)	www.national.com/wireless		

THE CONTENTS OF THIS DOCUMENT ARE PROVIDED IN CONNECTION WITH NATIONAL SEMICONDUCTOR CORPORATION ("NATIONAL") PRODUCTS. NATIONAL MAKES NO REPRESENTATIONS OR WARRANTIES WITH RESPECT TO THE ACCURACY OR COMPLETENESS OF THE CONTENTS OF THIS PUBLICATION AND RESERVES THE RIGHT TO MAKE CHANGES TO SPECIFICATIONS AND PRODUCT DESCRIPTIONS AT ANY TIME WITHOUT NOTICE. NO LICENSE, WHETHER EXPRESS, IMPLIED, ARISING BY ESTOPPEL OR OTHERWISE, TO ANY INTELLECTUAL PROPERTY RIGHTS IS GRANTED BY THIS DOCUMENT.

TESTING AND OTHER QUALITY CONTROLS ARE USED TO THE EXTENT NATIONAL DEEMS NECESSARY TO SUPPORT NATIONAL'S PRODUCT WARRANTY. EXCEPT WHERE MANDATED BY GOVERNMENT REQUIREMENTS, TESTING OF ALL PARAMETERS OF EACH PRODUCT IS NOT NECESSARILY PERFORMED. NATIONAL ASSUMES NO LIABILITY FOR APPLICATIONS ASSISTANCE OR BUYER PRODUCT DESIGN. BUYERS ARE RESPONSIBLE FOR THEIR PRODUCTS AND APPLICATIONS USING NATIONAL COMPONENTS. PRIOR TO USING OR DISTRIBUTING ANY PRODUCTS THAT INCLUDE NATIONAL COMPONENTS, BUYERS SHOULD PROVIDE ADEQUATE DESIGN, TESTING AND OPERATING SAFEGUARDS.

EXCEPT AS PROVIDED IN NATIONAL'S TERMS AND CONDITIONS OF SALE FOR SUCH PRODUCTS, NATIONAL ASSUMES NO LIABILITY WHATSOEVER, AND NATIONAL DISCLAIMS ANY EXPRESS OR IMPLIED WARRANTY RELATING TO THE SALE AND/OR USE OF NATIONAL PRODUCTS INCLUDING LIABILITY OR WARRANTIES RELATING TO FITNESS FOR A PARTICULAR PURPOSE, MERCHANTABILITY, OR INFRINGEMENT OF ANY PATENT, COPYRIGHT OR OTHER INTELLECTUAL PROPERTY RIGHT.

LIFE SUPPORT POLICY

NATIONAL'S PRODUCTS ARE NOT AUTHORIZED FOR USE AS CRITICAL COMPONENTS IN LIFE SUPPORT DEVICES OR SYSTEMS WITHOUT THE EXPRESS PRIOR WRITTEN APPROVAL OF THE CHIEF EXECUTIVE OFFICER AND GENERAL COUNSEL OF NATIONAL SEMICONDUCTOR CORPORATION. As used herein:

Life support devices or systems are devices which (a) are intended for surgical implant into the body, or (b) support or sustain life and whose failure to perform when properly used in accordance with instructions for use provided in the labeling can be reasonably expected to result in a significant injury to the user. A critical component is any component in a life support device or system whose failure to perform can be reasonably expected to cause the failure of the life support device or system or to affect its safety or effectiveness.

National Semiconductor and the National Semiconductor logo are registered trademarks of National Semiconductor Corporation. All other brand or product names may be trademarks or registered trademarks of their respective holders.

Copyright© 2008 National Semiconductor Corporation

For the most current product information visit us at www.national.com



**National Semiconductor
Americas Technical
Support Center**
Email:
new.feedback@nsc.com
Tel: 1-800-272-9959

**National Semiconductor Europe
Technical Support Center**
Email: europe.support@nsc.com
German Tel: +49 (0) 180 5010 771
English Tel: +44 (0) 870 850 4288

**National Semiconductor Asia
Pacific Technical Support Center**
Email: ap.support@nsc.com

**National Semiconductor Japan
Technical Support Center**
Email: jpn.feedback@nsc.com

IMPORTANT NOTICE

Texas Instruments Incorporated and its subsidiaries (TI) reserve the right to make corrections, modifications, enhancements, improvements, and other changes to its products and services at any time and to discontinue any product or service without notice. Customers should obtain the latest relevant information before placing orders and should verify that such information is current and complete. All products are sold subject to TI's terms and conditions of sale supplied at the time of order acknowledgment.

TI warrants performance of its hardware products to the specifications applicable at the time of sale in accordance with TI's standard warranty. Testing and other quality control techniques are used to the extent TI deems necessary to support this warranty. Except where mandated by government requirements, testing of all parameters of each product is not necessarily performed.

TI assumes no liability for applications assistance or customer product design. Customers are responsible for their products and applications using TI components. To minimize the risks associated with customer products and applications, customers should provide adequate design and operating safeguards.

TI does not warrant or represent that any license, either express or implied, is granted under any TI patent right, copyright, mask work right, or other TI intellectual property right relating to any combination, machine, or process in which TI products or services are used. Information published by TI regarding third-party products or services does not constitute a license from TI to use such products or services or a warranty or endorsement thereof. Use of such information may require a license from a third party under the patents or other intellectual property of the third party, or a license from TI under the patents or other intellectual property of TI.

Reproduction of TI information in TI data books or data sheets is permissible only if reproduction is without alteration and is accompanied by all associated warranties, conditions, limitations, and notices. Reproduction of this information with alteration is an unfair and deceptive business practice. TI is not responsible or liable for such altered documentation. Information of third parties may be subject to additional restrictions.

Resale of TI products or services with statements different from or beyond the parameters stated by TI for that product or service voids all express and any implied warranties for the associated TI product or service and is an unfair and deceptive business practice. TI is not responsible or liable for any such statements.

TI products are not authorized for use in safety-critical applications (such as life support) where a failure of the TI product would reasonably be expected to cause severe personal injury or death, unless officers of the parties have executed an agreement specifically governing such use. Buyers represent that they have all necessary expertise in the safety and regulatory ramifications of their applications, and acknowledge and agree that they are solely responsible for all legal, regulatory and safety-related requirements concerning their products and any use of TI products in such safety-critical applications, notwithstanding any applications-related information or support that may be provided by TI. Further, Buyers must fully indemnify TI and its representatives against any damages arising out of the use of TI products in such safety-critical applications.

TI products are neither designed nor intended for use in military/aerospace applications or environments unless the TI products are specifically designated by TI as military-grade or "enhanced plastic." Only products designated by TI as military-grade meet military specifications. Buyers acknowledge and agree that any such use of TI products which TI has not designated as military-grade is solely at the Buyer's risk, and that they are solely responsible for compliance with all legal and regulatory requirements in connection with such use.

TI products are neither designed nor intended for use in automotive applications or environments unless the specific TI products are designated by TI as compliant with ISO/TS 16949 requirements. Buyers acknowledge and agree that, if they use any non-designated products in automotive applications, TI will not be responsible for any failure to meet such requirements.

Following are URLs where you can obtain information on other Texas Instruments products and application solutions:

Products

Audio	www.ti.com/audio
Amplifiers	amplifier.ti.com
Data Converters	dataconverter.ti.com
DLP® Products	www.dlp.com
DSP	dsp.ti.com
Clocks and Timers	www.ti.com/clocks
Interface	interface.ti.com
Logic	logic.ti.com
Power Mgmt	power.ti.com
Microcontrollers	microcontroller.ti.com
RFID	www.ti-rfid.com
OMAP Mobile Processors	www.ti.com/omap
Wireless Connectivity	www.ti.com/wirelessconnectivity

Applications

Communications and Telecom	www.ti.com/communications
Computers and Peripherals	www.ti.com/computers
Consumer Electronics	www.ti.com/consumer-apps
Energy and Lighting	www.ti.com/energy
Industrial	www.ti.com/industrial
Medical	www.ti.com/medical
Security	www.ti.com/security
Space, Avionics and Defense	www.ti.com/space-avionics-defense
Transportation and Automotive	www.ti.com/automotive
Video and Imaging	www.ti.com/video

TI E2E Community Home Page

e2e.ti.com

Mailing Address: Texas Instruments, Post Office Box 655303, Dallas, Texas 75265
Copyright © 2011, Texas Instruments Incorporated