

Using the TPS40140EVM-003

User's Guide



Literature Number: SLVU219A
August 2007–Revised November 2010

Using the TPS40140EVM-003 A 32-A Single Output Two-Phase Stackable Synchronous Buck Converter

The TPS40140EVM-003 evaluation module (EVM) is a single output two-phase synchronous buck converter. The EVM delivers 1.5 V at 32 A. The module uses the TPS40140 dual or 2-phase stackable synchronous buck controller. The EVM is also stackable with the other EVM to construct a multiphase converter.

1 Description

TPS40140EVM-003 is designed to use a regulated 10.8-V to 13.2-V bus to produce high-current regulated output. The TPS40140EVM-003 evaluation module demonstrates the TPS40140 in a typical regulated bus to low-voltage application while providing a number of test points to evaluate the performance of the TPS40140 in a given application.

1.1 Applications

- Graphics Cards
- Internet Servers
- Networking Equipment
- Telecommunications Equipment
- DC Power Distributed Systems

1.2 Features

- 10.8-V to 13.2-V Input Range
- 1.5-V Fixed Output
- 32-A_{DC} Steady State Current per Output
- 300-kHz Switching Frequency per Phase
- Single Main Switch N-channel MOSFET and Two Synchronous Rectifier N-channel MOSFETs per Phase
- Convenient Test Points for Probing Critical Waveforms and Non-Invasive Loop Response Testing

2 TPS40140EVM-003 Electrical Performance Specifications

Table 1. TPS40140EVM-003 Electrical and Performance Specifications

PARAMETER	CONDITIONS	MIN	TYP	MAX	UNIT
Input Characteristics					
Input Voltage Range		10.8		13.2	V
Max Input Current	$V_{IN} = 10.8\text{ V}$, $I_{OUT} = 32\text{ A}$		4.98		A
No-Load Input Current	$V_{IN} = 13.2\text{ V}$, $I_{OUT} = 0\text{ A}$		130		mA
Output Characteristics (V_{OUT})					
Output Voltage			1.51		V
Output Voltage Regulation	Line Regulation ($10.8\text{ V} < V_{IN} < 13.2\text{ V}$, $I_{OUT} = 10\text{ A}$)			0.1%	
	Load Regulation ($0\text{ A} < I_{OUT} < 32\text{ A}$, $V_{IN} = 12\text{ V}$)			0.5%	
Output Voltage Ripple	$V_{IN} = 13.2\text{ V}$, $I_{OUT} = 32\text{ A}$			40	mVpp
Output Load Current	I_{OUT}	0		32	A
Output Over Current			40		A
System Characteristics					
Switching Frequency			300		kHz
Peak Efficiency	$V_{OUT} = 1.5\text{ V}$, $I_{OUT} = 20\text{ A}$, $V_{IN} = 10.8\text{ V}$		91%		
Full Load Efficiency	$V_{OUT} = 1.5\text{ V}$, $I_{OUT} = 32\text{ A}$, $V_{IN} = 12\text{ V}$		89.9%		

3 Schematic

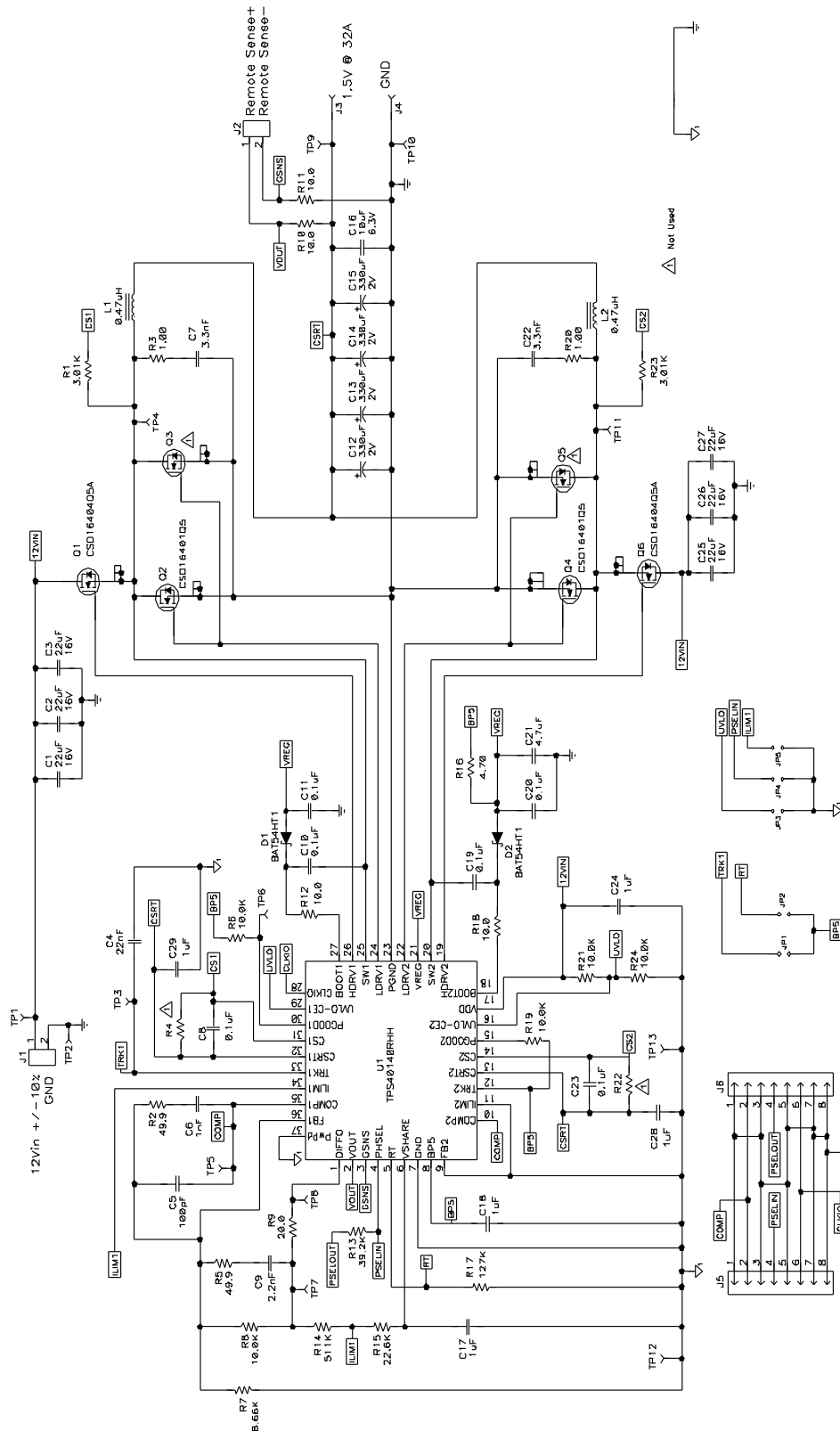

Figure 1. TPS40140EVM-003 Schematic
(for reference only, see List of Materials for specific values)

4 Test Set Up

4.1 Recommended Test Equipment

4.1.1 Voltage Source

 V_{IN}

The input voltage source (V_{IN}) should be a 0 V to 15V variable DC source capable of 10 A_{DC}. Connect V_{IN} to J1 as shown in [Figure 2](#).

4.1.2 Meters

V1: V_{IN} , 0 V to 15V voltmeter

V2: V_{OUT} , 0 V to 5V voltmeter

I1: 0 V to 10A current meter

4.1.3 Load

LOAD

The Output Load (LOAD) should be an Electronic Constant Current Mode Load capable of 0–40A_{dc} at 1.5V

4.1.4 Oscilloscope

A Digital or Analog Oscilloscope can be used to measure the ripple voltage on V_{OUT} . The Oscilloscope should be set for 1M Ω impedance, 20MHz Bandwidth, AC coupling, 1 μ s/division horizontal resolution, 10mV/division vertical resolution for taking output ripple measurements. Test points TP9 and TP10 can be used to measure the output ripple voltage by placing the oscilloscope probe tip through TP9 and holding the ground barrel to TP10 as shown in [Figure 3](#). Using a leaded ground connection may induce additional noise due to the large ground loop area.

4.1.5 Recommended Wire Gauge

V_{IN} to J1

The connection between the source voltage, V_{IN} and J1 of the EVM can carry as much as 6 Amps DC. The minimum recommended wire size is 1x AWG #16 per input connection, with the total length of wire less than 4 feet (2 feet input, 2 feet return).

J3, J4 to LOAD (Power)

The power connection between J3 and J4 of the EVM and LOAD can carry as much as 32A_{dc}. The minimum recommended wire size is 2x AWG #14, with the total length of wire less than 4 feet (2 feet output, 2 feet return).

4.1.6 Other

FAN

This evaluation module includes components that can get hot to the touch, because this EVM is not enclosed to allow probing of circuit nodes, a small fan capable of 200-400 lfm is required to reduce component surface temperatures to prevent user injury. The EVM should not be left unattended while powered. The EVM should not be probed while the fan is not running.

4.2 Equipment Setup

Shown in [Figure 2](#) is the basic test set up recommended to evaluate the TPS40140EVM-003.

Working at an ESD workstation, make sure that any wrist straps, bootstraps or mats are connected referencing the user to earth ground before power is applied to the EVM. Electrostatic smock and safety glasses should also be worn.

4.2.1 Input Connections

1. Prior to connecting the DC input source, V_{IN} , it is advisable to limit the source current from V_{IN} to 6A maximum. Make sure V_{IN} is initially set to 0V and connected as shown in [Figure 2](#).

4.2.2 Output Connections

1. Connect LOAD to J3 and J4, set LOAD to constant current mode to sink 0 A before V_{IN} is applied.
2. Connect voltmeter, V2, across TP9 and TP10, as shown in [Figure 2](#).

4.2.3 Other Connections

1. Place Fan as shown in [Figure 2](#) and turn on, making sure air is flowing across the EVM.

4.2.4 Set Up Diagram

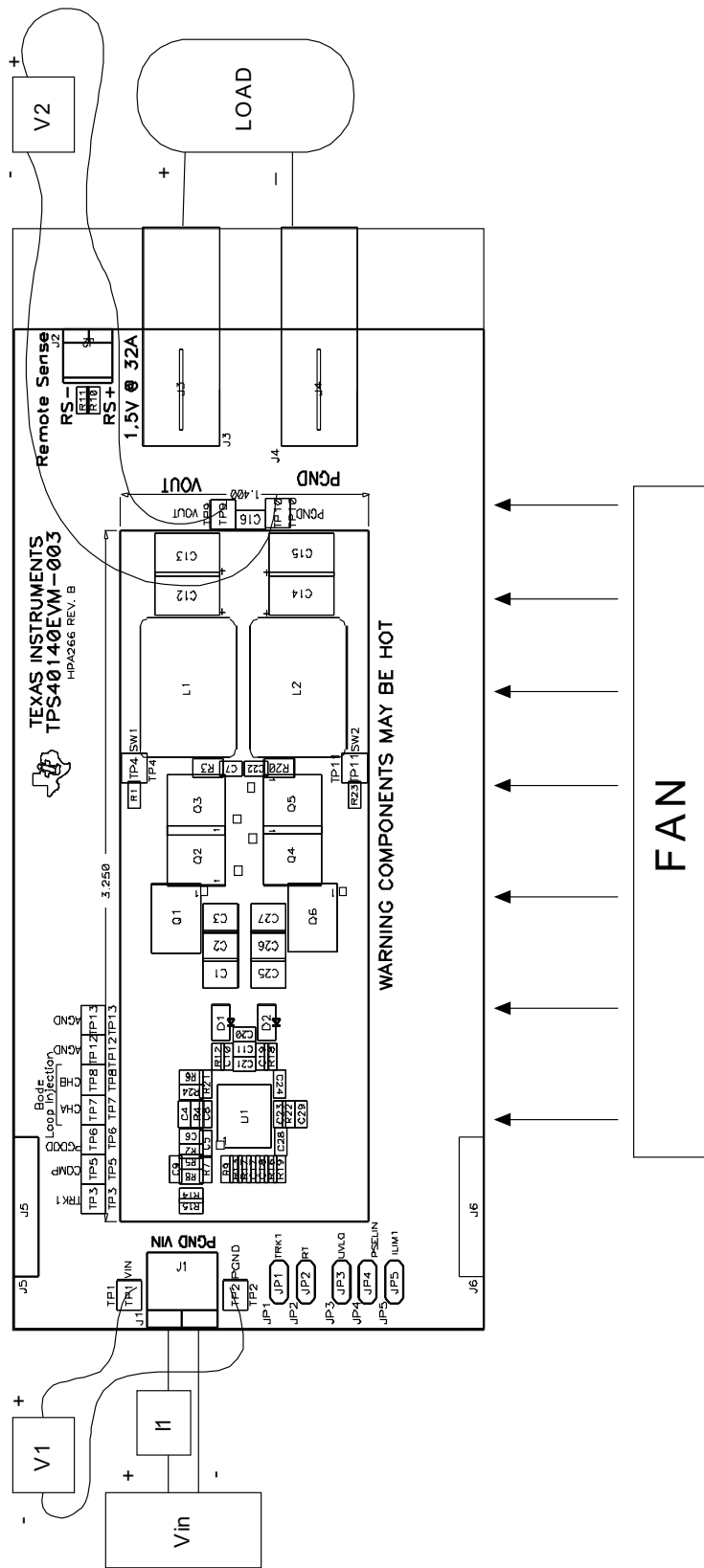

Figure 2. TPS40140EVM-003 Recommended Test Set-Up

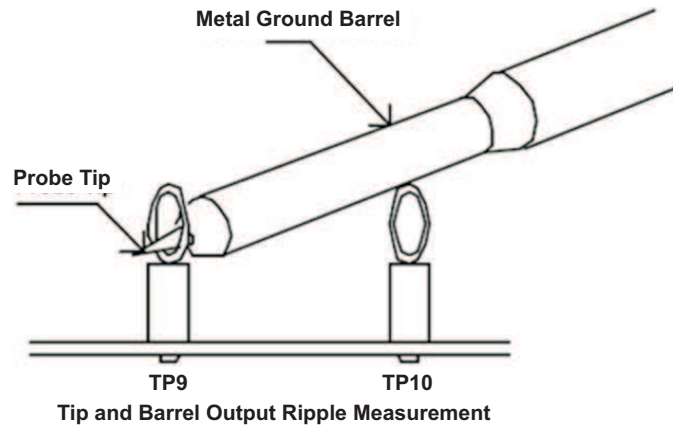

Figure 3. Output Ripple Measurement

4.3 Start Up and Test Procedure

1. Ensure LOAD is set to constant current mode and to sink 0 Adc.
2. Increase V_{IN} from 0 V to 10.8 Vdc, V_{OUT} should be in regulation per [Table 1](#). Continue increasing V_{IN} to 12 V.
3. Vary LOAD from 0 to 32 Adc, V_{OUT} should remain in regulation per [Table 1](#).
4. Vary V_{IN} from 10.8 Vdc to 13.2 Vdc, V_{OUT} should remain in regulation per [Table 1](#).
5. For various V_{IN} settings vary LOAD from 0 to 32 Adc. V_{OUT} should remain in regulation per [Table 1](#) for all combinations of load on LOAD up to 32 A.

4.4 Control Loop Gain and Phase Measurement Procedure

1. Connect 1 kHz–1 MHz Isolation Transformer to test points marked CHA and CHB.
2. Connect Input Signal Amplitude Measurement Probe (Channel A) to CHA.
3. Connect Output Signal Amplitude Measurement Probe (Channel B) to CHB.
4. Connect Ground Lead of Channel A and Channel B to AGND
5. Inject 25 mV or less signal through the Isolation Transformer.
6. Sweep Frequency from 100 Hz to 1 MHz with 10 Hz or lower post filter.

$$20 \times \text{LOG} \left(\frac{\text{Channel B}}{\text{Channel A}} \right)$$

7. Control Loop Gain can be measured by
8. Control Loop Phase is measured by the Phase difference between Channel A and Channel B.
9. Disconnect Isolation Transformer from the bode plot test points before making other measurements (Signal Injection into Feedback may interfere with accuracy of other measurements).

4.5 EVM Configuration

4.5.1 Two Phase Single Output Configuration (Default)

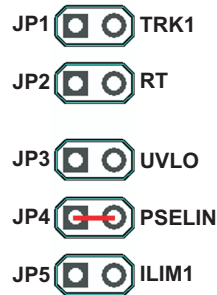

Figure 4. Default Configuration

JP4 is shorted with a jumper and others are left open. In this configuration, the EVM operates as a two phase single output converter.

4.5.2 Disabling the Output

JP3 allows the user to disable or enable the output. The output is disabled by shorting JP3 with a Jumper.

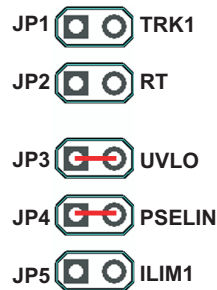

Figure 5. Output Disable Configuration

4.5.3 Multiphase Configuration

This EVM is stackable with other identical boards. For example, two EVMs can construct a fully interleaved four phase converter. In [Figure 6](#), the EVM is configured as a master while stacking with the other EVM board.

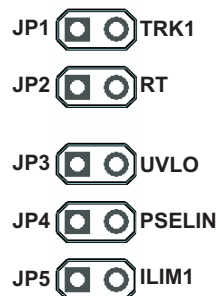

Figure 6. Configure the EVM as a Master for Stackable Operation

If two EVM boards are stacked together, the other EVM is configured as a slave as shown in [Figure 7](#).



Figure 7. Configure the EVM as a Slave for Stackable Operation

If more than two EVM boards are stacked, for example three, the two slave EVMs have slightly different settings. Considering the master is the first board in the chain and all others are slaves, JP4 in the last slave board should be shorted by a jumper while it is left as open in other slave boards. The configurations are shown in [Figure 8](#).

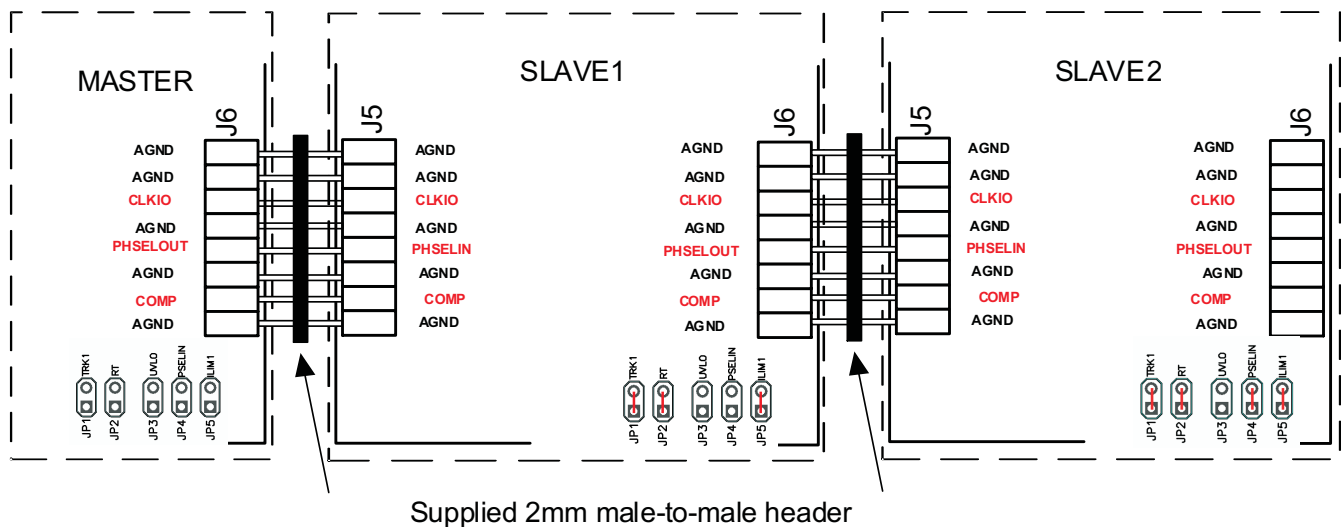

Figure 8. Master and Slave Connection (this EVM is the slave)

J5 and J6 are used to connect the EVM to the other EVM boards. Male-to-male headers are provided to make the connections between the boards.

4.6 Test Points

Several test points are located around the board. These can be used to sense what is occurring at different points of the converter. [Table 2](#) lists these test points and what they are used for.

Table 2. List of Test Points

NAME	TEST POINT LABEL	DESCRIPTION
TP1	VIN	Input voltage positive sense point
TP2	PGND	Input voltage negative sense point
TP3	TRK1	Soft Start
TP4	SW1	Channel 1 switch node
TP5	COMP	Error amplifier output
TP6	PGOOD	Power Good
TP7	CHA	Loop injection point CHA
TP8	CHB	Loop injection point CHB
TP9	VOUT	Output positive sense point
TP10	PGND	Output negative sense point
TP11	SW2	Channel 2 switch node
TP12	AGND	Analog Ground
TP13	AGND	Analog Ground

4.7 Equipment Shutdown

1. Shut down LOAD
2. Shut down V_{IN}
3. Shut down FAN

5 TPS40140EVM-003 Typical Performance Data and Characteristic Curves

Figure 9 through Figure 13 present typical performance curves for the TPS40140EVM-003. Since actual performance data can be affected by measurement techniques and environmental variables, these curves are presented for reference and may differ from actual field measurements.

5.1 Efficiency and Power Loss

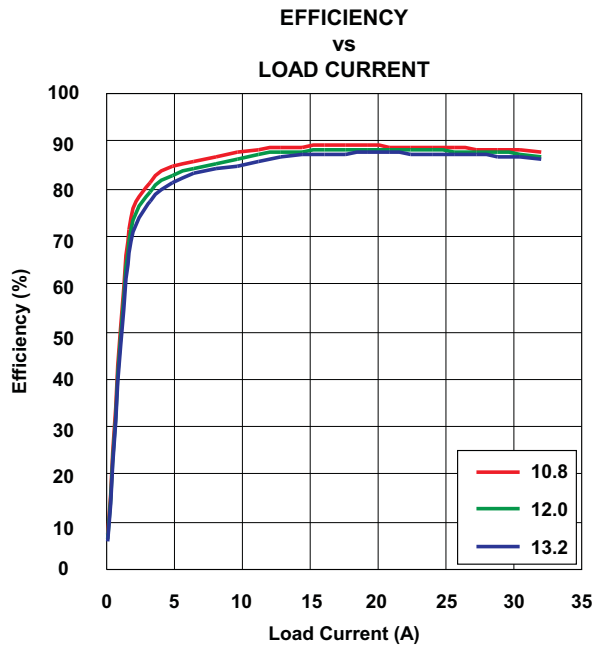

Figure 9. TPS40140EVM-003 Efficiency
 $V_{IN} = 10.8\text{--}13.2\text{ V}$, $V_{OUT} = 1.5\text{ V}$, $I_{OUT} = 0\text{--}32\text{ A}$

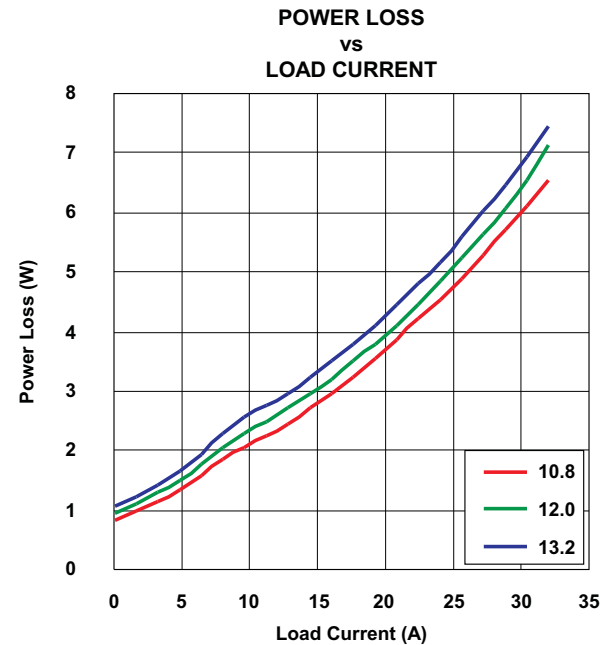

Figure 10. TPS40140EVM-003 $V_{OUT} = 1.5\text{-V}$ Power Loss

5.2 Line and Load Regulation

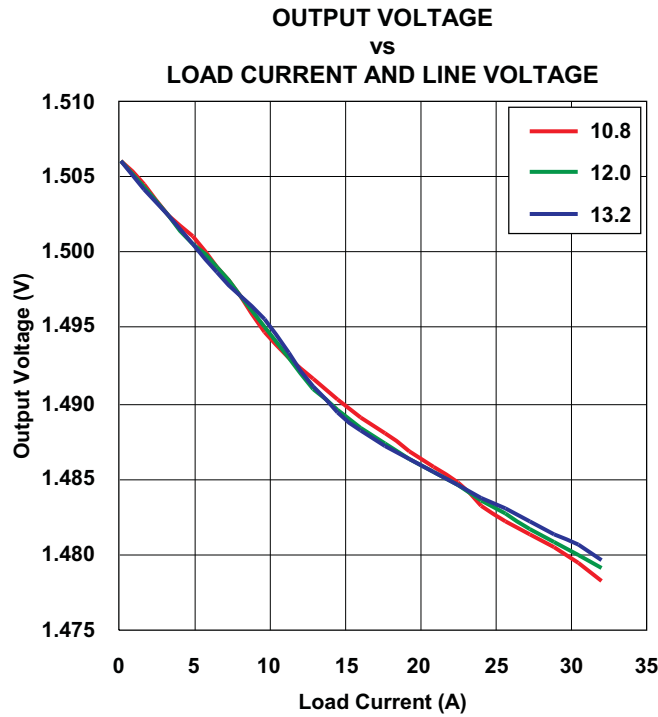

Figure 11. TPS40140EVM-003 $V_{OUT} = 1.5\text{-V}$ Line and Load Regulation

5.3 Bode Plot

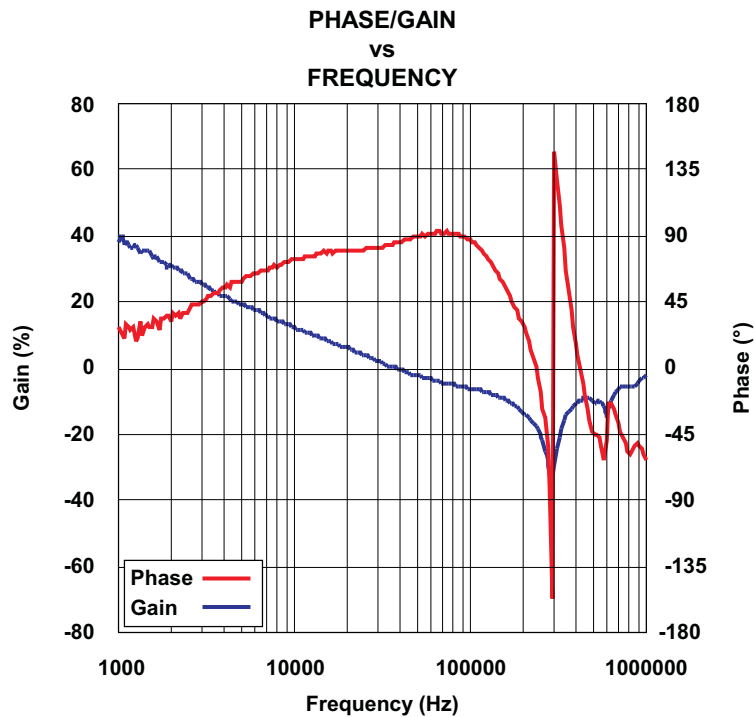

Figure 12. TPS40140EVM-003 Loop Gain, BW = 25 kHz, Phase Margin = 82°

5.4 Transient Response

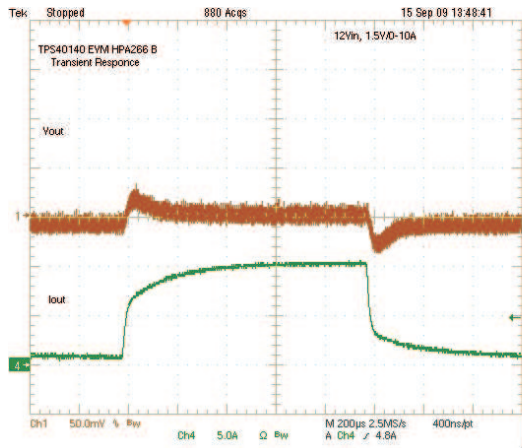

Figure 13. Transient Response 10 A Step, 2.5 A/ μ s, 50 mV/div
Ch1: V_{OUT}; Ch4: I_{OUT}

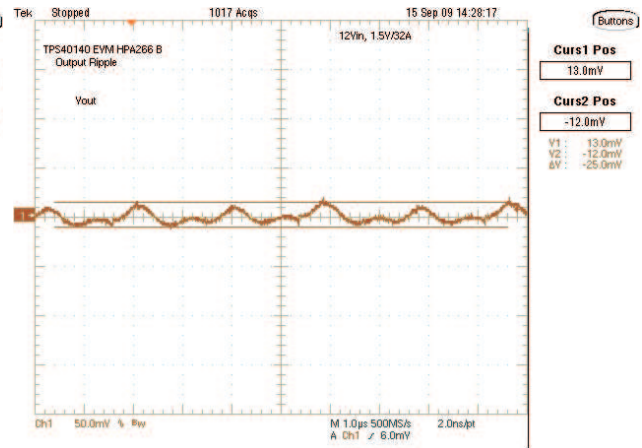

Figure 14. Output Ripple

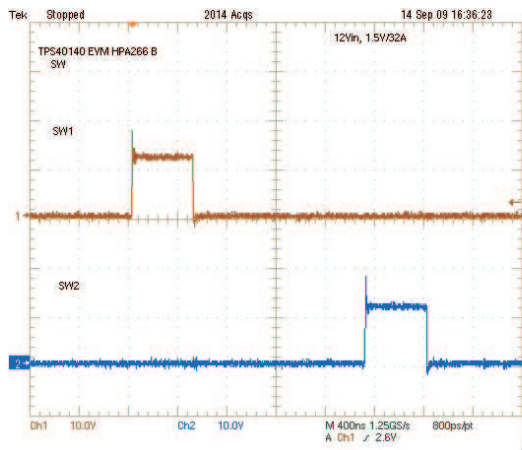

Figure 15. SW Node

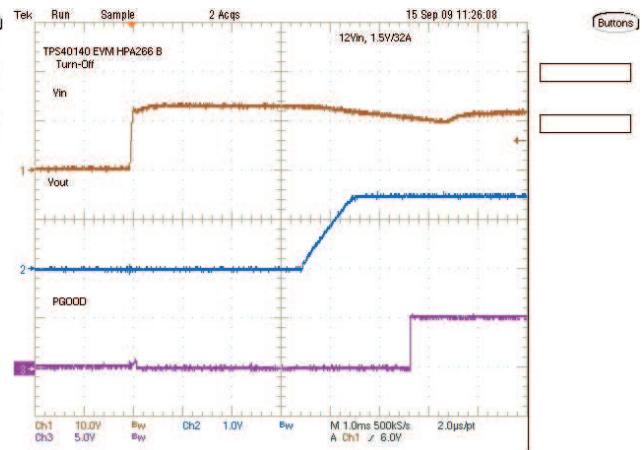

Figure 16. Turn ON

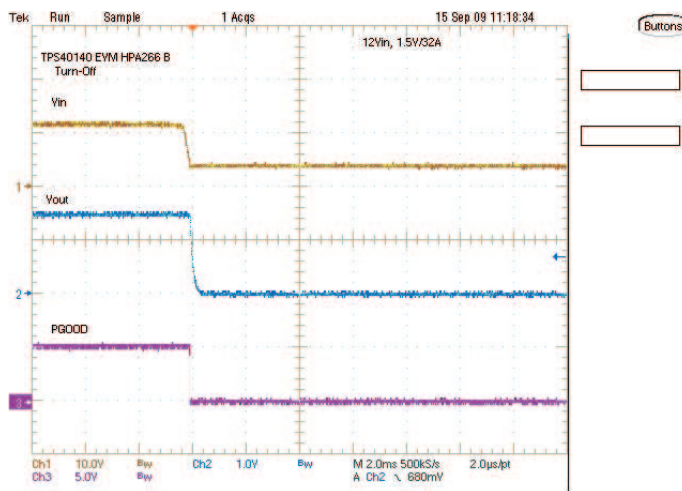

Figure 17. Turn OFF

6 EVM Assembly Drawings and Layout

Figure 18 through Figure 22 show the design of the TPS40140EVM-003 printed circuit board. The EVM has been designed using a four layer, 2 oz copper-clad circuit board with all components on the top side to allow the user to easily view, probe and evaluate the TPS40140 control IC in a practical application. Moving components to both sides of the PCB or using additional internal layers can offer additional size reduction for space constrained systems.

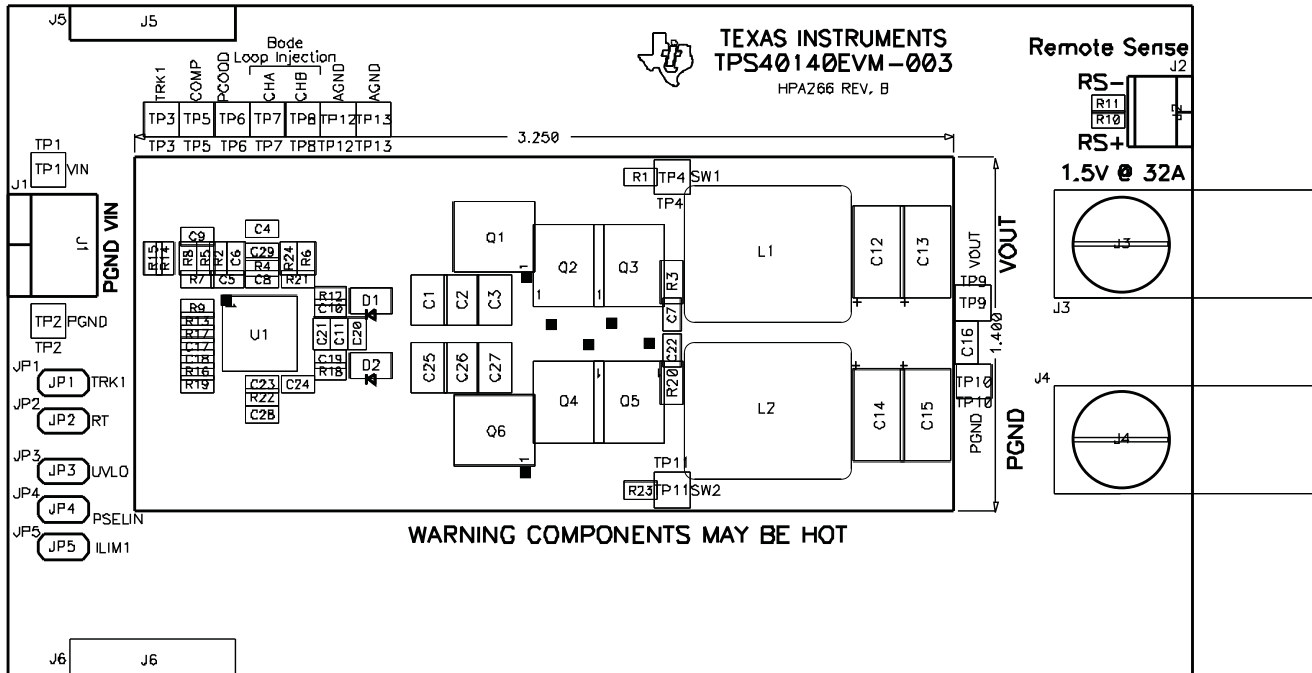

Figure 18. TPS40140EVM-003 Component Placement (Viewed from Top)

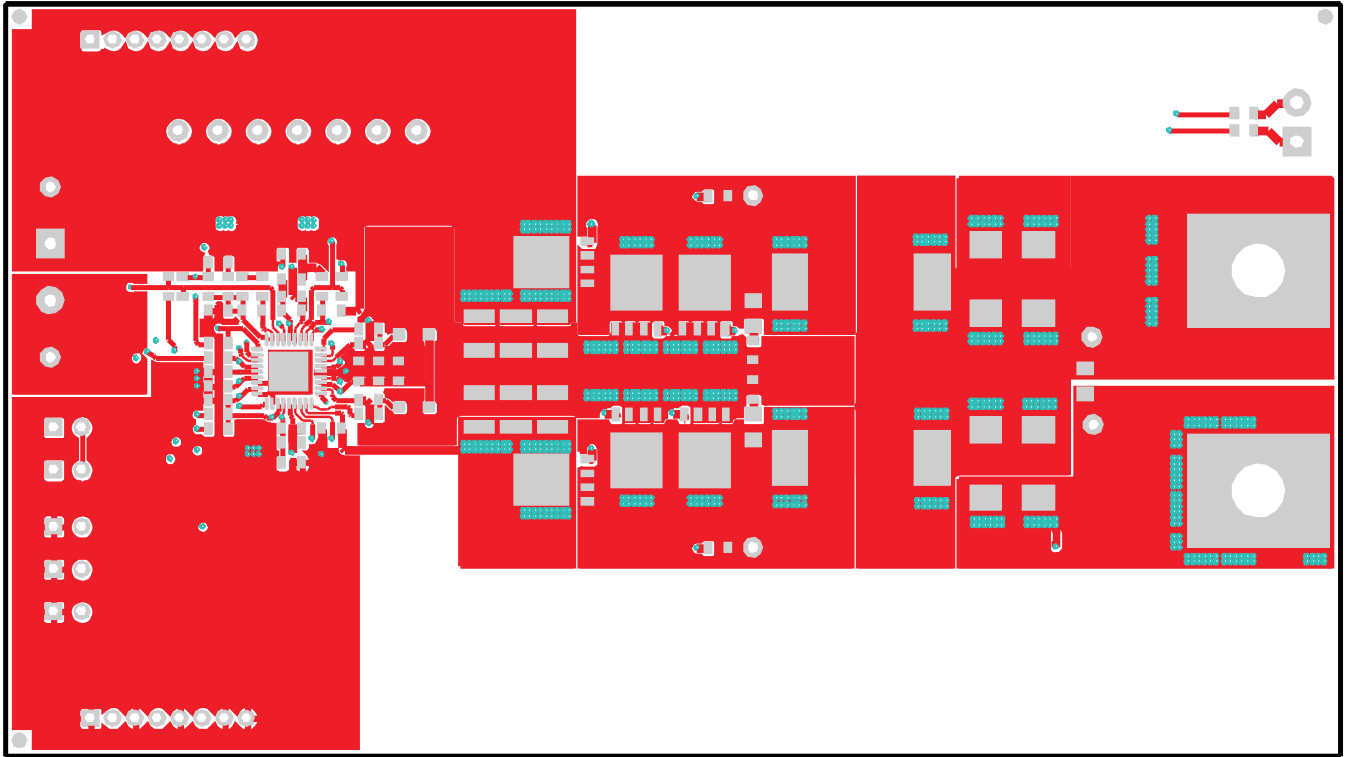

Figure 19. TPS40140EVM-003 Top Copper (Viewed from Top)

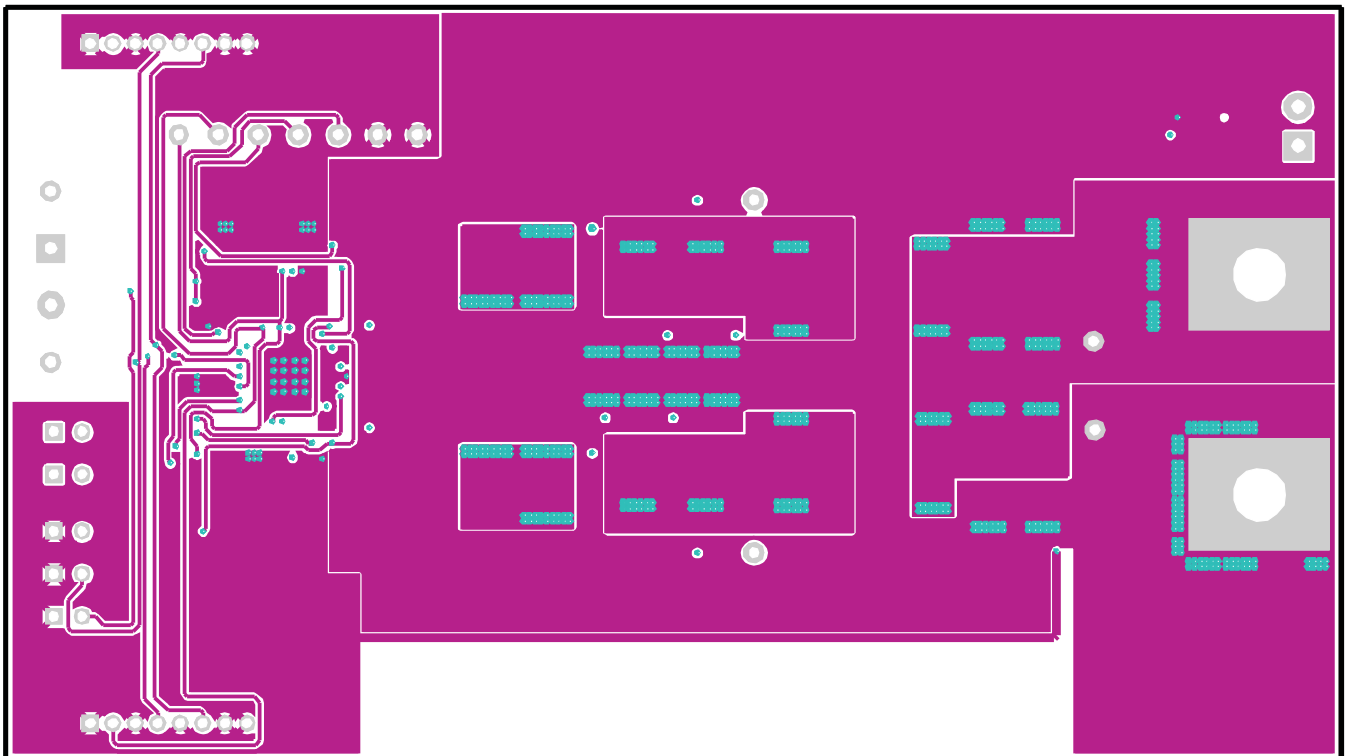

Figure 20. TPS40140EVM-003 Layer 2 Copper (X-Ray View from Top)

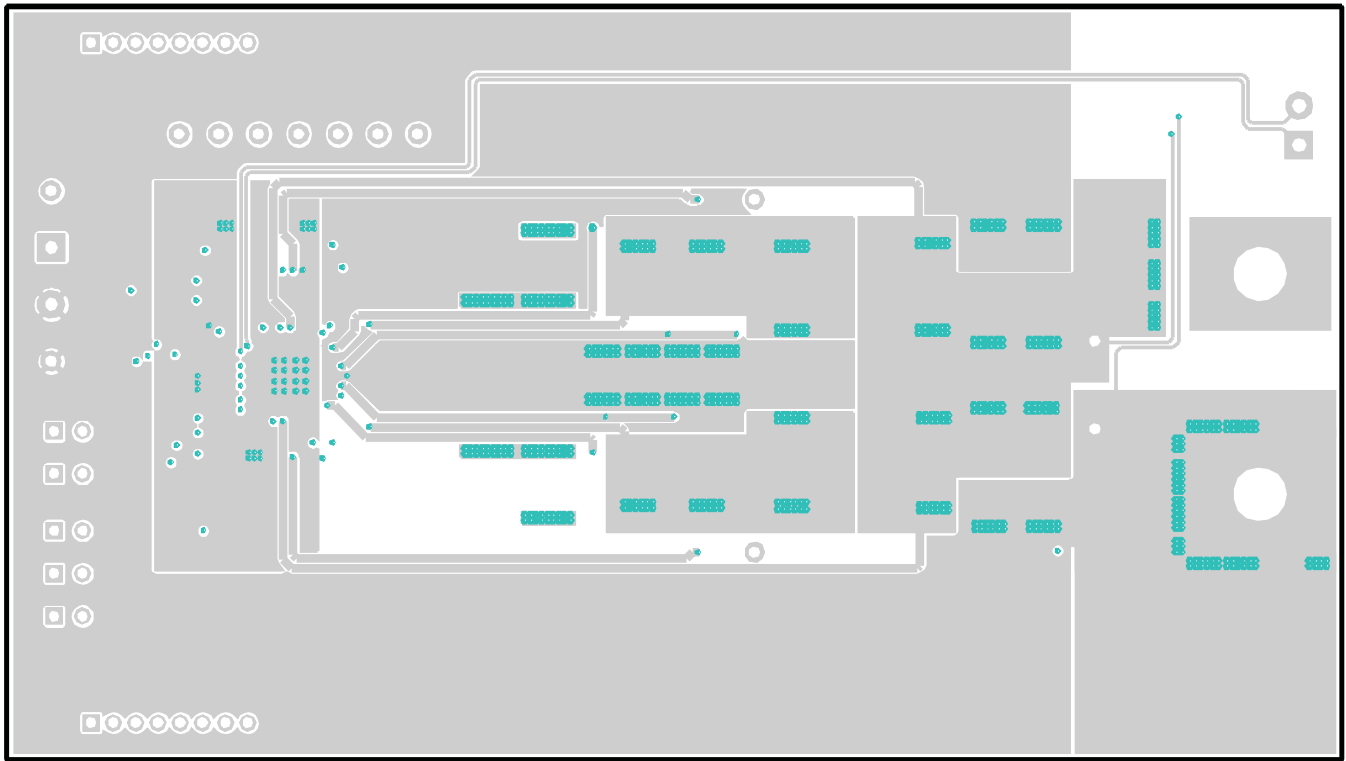

Figure 21. TPS40140EVM-003 Layer 3 Copper (X-Ray View from Top)

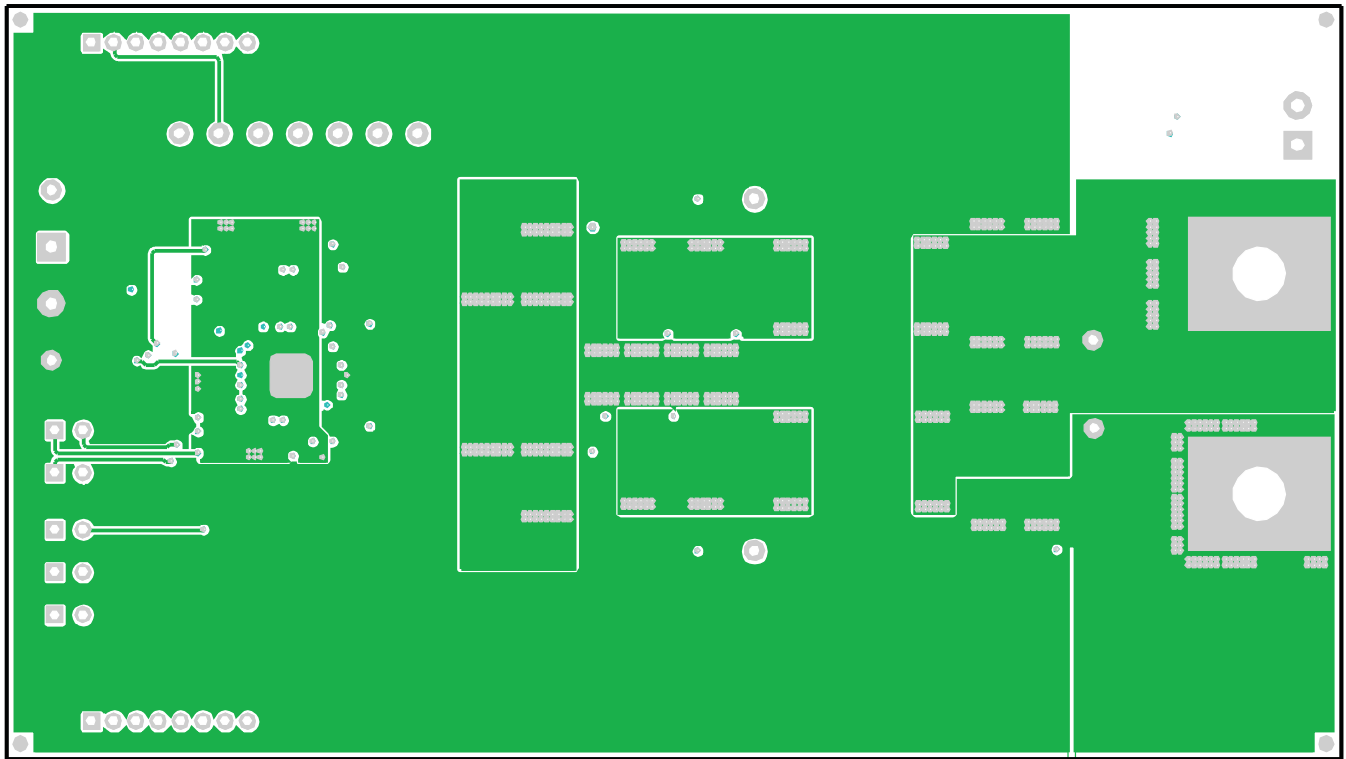

Figure 22. TPS40140EVM-003 Bottom Copper (X-Ray View from Top)

7 List of Materials

Table 3 lists the EVM components as configured according to the schematic shown in Figure 1.

Table 3. TPS40140EVM-003 List of Materials

COUNT	REFDES	DESCRIPTION	PART NUMBER	MFR
6	C1–C3, C25–C27	Capacitor, ceramic, 16 V, X5R, 20%, 22 μ F	Std	Std
4	C12–C15	Capacitor, SP cap, 2 V, 0.006 Ω , 20%, 330 μ F, 7343	EEFSX0D331XE	Panasonic
1	C16	Capacitor, ceramic, 6.3 V, X5R, 10%, 10 μ F, 805	Std	Std
5	C17, C18, C24, C28, C29	Capacitor, ceramic, 16 V, X5R, 10%, 1 μ F, 603	Std	Std
1	C21	Capacitor, ceramic, 6.3 V, X5R, 10%, 4.7 μ F, 603	Std	Std
1	C4	Capacitor, ceramic, 16 V, X7R, 10%, 22 nF, 603	Std	Std
1	C5	Capacitor, ceramic, 16 V, X7R, 10%, 100 pF, 603	Std	Std
1	C6	Capacitor, ceramic, 16 V, X7R, 10%, 1000 pF, 603	Std	Std
2	C7, C22	Capacitor, ceramic, 16 V, X7R, 10%, 3.3 nF, 603	Std	Std
6	C8, C10, C11, C19, C20, C23	Capacitor, ceramic, 16 V, X7R, 10%, 0.1 μ F, 603	Std	Std
1	C9	Capacitor, ceramic, 16 V, X7R, 10%, 2.2 nF, 603	Std	Std
2	D1, D2	Diode, Schottky, 30 V, 0.35 Vf, SOD323	BAT54HT1	On Semi
2	L1, L2	Inductor, SMT, 41 A, 0.001 Ω , 0.47 μ H, 0.512 \times 0.571 in	IHLP-5050FD-0R47-M01	Vishay
2	Q1, Q6	MOSFET, N-channel, 25 V, 21A, 0.0041 Ω	CSD16404Q5A	TI
2	Q2, Q4	MOSFET, N-channel, 25 V, 38A, 0.0018 Ω	CSD16401Q5	TI
0	Q3, Q5	MOSFET, N-channel, 25 V, 38A, 0.0018 Ω	CSD16401Q5	TI
2	R1, R23	Resistor, chip, 1/16 W, 1%, 3.01 k Ω , 603	Std	Std
4	R10–R12, R18	Resistor, chip, 1/16 W, 1%, 10.0 Ω , 603	Std	Std
1	R16	Resistor, chip, 1/16 W, 1%, 4.70 Ω , 603	Std	Std
1	R14	Resistor, chip, 1/16 W, 1%, 511 k Ω , 603	Std	Std
1	R15	Resistor, chip, 1/16 W, 1%, 22.6 k Ω , 603	Std	Std
1	R17	Resistor, chip, 1/16 W, 1%, 127 k Ω , 603	Std	Std
1	R13	Resistor, chip, 1/16 W, 1%, 39.2 k Ω , 603	Std	Std
2	R3, R20	Resistor, chip, 1/8 W, 1%, 1.00 Ω , 805	Std	Std
1	R9	Resistor, chip, 1/16 W, 1%, 20.0 Ω , 603	Std	Std
0	R4, R22	Resistor, chip, 1/16 W, 1%, OPEN, 603	Std	Std
2	R2,R5	Resistor, chip, 1/16 W, 1%, 49.9 Ω , 603	Std	Std
5	R6, R8, R19, R21, R24	Resistor, chip, 1/16 W, 1%, 10.0 k Ω , 603	Std	Std
1	R7	Resistor, chip, 1/16 W, 1%, 8.66 k Ω , 603	Std	Std
1	U1	2-Phase or Dual Output PWM Controller, QFN-36	TPS40140RHH	Texas Instruments

EVALUATION BOARD/KIT IMPORTANT NOTICE

Texas Instruments (TI) provides the enclosed product(s) under the following conditions:

This evaluation board/kit is intended for use for **ENGINEERING DEVELOPMENT, DEMONSTRATION, OR EVALUATION PURPOSES ONLY** and is not considered by TI to be a finished end-product fit for general consumer use. Persons handling the product(s) must have electronics training and observe good engineering practice standards. As such, the goods being provided are not intended to be complete in terms of required design-, marketing-, and/or manufacturing-related protective considerations, including product safety and environmental measures typically found in end products that incorporate such semiconductor components or circuit boards. This evaluation board/kit does not fall within the scope of the European Union directives regarding electromagnetic compatibility, restricted substances (RoHS), recycling (WEEE), FCC, CE or UL, and therefore may not meet the technical requirements of these directives or other related directives.

Should this evaluation board/kit not meet the specifications indicated in the User's Guide, the board/kit may be returned within 30 days from the date of delivery for a full refund. **THE FOREGOING WARRANTY IS THE EXCLUSIVE WARRANTY MADE BY SELLER TO BUYER AND IS IN LIEU OF ALL OTHER WARRANTIES, EXPRESSED, IMPLIED, OR STATUTORY, INCLUDING ANY WARRANTY OF MERCHANTABILITY OR FITNESS FOR ANY PARTICULAR PURPOSE.**

The user assumes all responsibility and liability for proper and safe handling of the goods. Further, the user indemnifies TI from all claims arising from the handling or use of the goods. Due to the open construction of the product, it is the user's responsibility to take any and all appropriate precautions with regard to electrostatic discharge.

EXCEPT TO THE EXTENT OF THE INDEMNITY SET FORTH ABOVE, NEITHER PARTY SHALL BE LIABLE TO THE OTHER FOR ANY INDIRECT, SPECIAL, INCIDENTAL, OR CONSEQUENTIAL DAMAGES.

TI currently deals with a variety of customers for products, and therefore our arrangement with the user **is not exclusive.**

TI assumes **no liability for applications assistance, customer product design, software performance, or infringement of patents or services described herein.**

Please read the User's Guide and, specifically, the Warnings and Restrictions notice in the User's Guide prior to handling the product. This notice contains important safety information about temperatures and voltages. For additional information on TI's environmental and/or safety programs, please contact the TI application engineer or visit www.ti.com/esh.

No license is granted under any patent right or other intellectual property right of TI covering or relating to any machine, process, or combination in which such TI products or services might be or are used.

FCC Warning

This evaluation board/kit is intended for use for **ENGINEERING DEVELOPMENT, DEMONSTRATION, OR EVALUATION PURPOSES ONLY** and is not considered by TI to be a finished end-product fit for general consumer use. It generates, uses, and can radiate radio frequency energy and has not been tested for compliance with the limits of computing devices pursuant to part 15 of FCC rules, which are designed to provide reasonable protection against radio frequency interference. Operation of this equipment in other environments may cause interference with radio communications, in which case the user at his own expense will be required to take whatever measures may be required to correct this interference.

EVM WARNINGS AND RESTRICTIONS

It is important to operate this EVM within the input voltage range of 10.8 V to 13.2 V and the output voltage range of 1.5 V at 0–32 A.

Exceeding the specified input range may cause unexpected operation and/or irreversible damage to the EVM. If there are questions concerning the input range, please contact a TI field representative prior to connecting the input power.

Applying loads outside of the specified output range may result in unintended operation and/or possible permanent damage to the EVM. Please consult the EVM User's Guide prior to connecting any load to the EVM output. If there is uncertainty as to the load specification, please contact a TI field representative.

During normal operation, some circuit components may have case temperatures greater than 85 °C. The EVM is designed to operate properly with certain components above 85 °C as long as the input and output ranges are maintained. These components include but are not limited to linear regulators, switching transistors, pass transistors, and current sense resistors. These types of devices can be identified using the EVM schematic located in the EVM User's Guide. When placing measurement probes near these devices during operation, please be aware that these devices may be very warm to the touch.

Mailing Address: Texas Instruments, Post Office Box 655303, Dallas, Texas 75265
Copyright © 2007, Texas Instruments Incorporated

IMPORTANT NOTICE

Texas Instruments Incorporated and its subsidiaries (TI) reserve the right to make corrections, modifications, enhancements, improvements, and other changes to its products and services at any time and to discontinue any product or service without notice. Customers should obtain the latest relevant information before placing orders and should verify that such information is current and complete. All products are sold subject to TI's terms and conditions of sale supplied at the time of order acknowledgment.

TI warrants performance of its hardware products to the specifications applicable at the time of sale in accordance with TI's standard warranty. Testing and other quality control techniques are used to the extent TI deems necessary to support this warranty. Except where mandated by government requirements, testing of all parameters of each product is not necessarily performed.

TI assumes no liability for applications assistance or customer product design. Customers are responsible for their products and applications using TI components. To minimize the risks associated with customer products and applications, customers should provide adequate design and operating safeguards.

TI does not warrant or represent that any license, either express or implied, is granted under any TI patent right, copyright, mask work right, or other TI intellectual property right relating to any combination, machine, or process in which TI products or services are used. Information published by TI regarding third-party products or services does not constitute a license from TI to use such products or services or a warranty or endorsement thereof. Use of such information may require a license from a third party under the patents or other intellectual property of the third party, or a license from TI under the patents or other intellectual property of TI.

Reproduction of TI information in TI data books or data sheets is permissible only if reproduction is without alteration and is accompanied by all associated warranties, conditions, limitations, and notices. Reproduction of this information with alteration is an unfair and deceptive business practice. TI is not responsible or liable for such altered documentation. Information of third parties may be subject to additional restrictions.

Resale of TI products or services with statements different from or beyond the parameters stated by TI for that product or service voids all express and any implied warranties for the associated TI product or service and is an unfair and deceptive business practice. TI is not responsible or liable for any such statements.

TI products are not authorized for use in safety-critical applications (such as life support) where a failure of the TI product would reasonably be expected to cause severe personal injury or death, unless officers of the parties have executed an agreement specifically governing such use. Buyers represent that they have all necessary expertise in the safety and regulatory ramifications of their applications, and acknowledge and agree that they are solely responsible for all legal, regulatory and safety-related requirements concerning their products and any use of TI products in such safety-critical applications, notwithstanding any applications-related information or support that may be provided by TI. Further, Buyers must fully indemnify TI and its representatives against any damages arising out of the use of TI products in such safety-critical applications.

TI products are neither designed nor intended for use in military/aerospace applications or environments unless the TI products are specifically designated by TI as military-grade or "enhanced plastic." Only products designated by TI as military-grade meet military specifications. Buyers acknowledge and agree that any such use of TI products which TI has not designated as military-grade is solely at the Buyer's risk, and that they are solely responsible for compliance with all legal and regulatory requirements in connection with such use.

TI products are neither designed nor intended for use in automotive applications or environments unless the specific TI products are designated by TI as compliant with ISO/TS 16949 requirements. Buyers acknowledge and agree that, if they use any non-designated products in automotive applications, TI will not be responsible for any failure to meet such requirements.

Following are URLs where you can obtain information on other Texas Instruments products and application solutions:

Products		Applications	
Amplifiers	amplifier.ti.com	Audio	www.ti.com/audio
Data Converters	dataconverter.ti.com	Automotive	www.ti.com/automotive
DLP® Products	www.dlp.com	Communications and Telecom	www.ti.com/communications
DSP	dsp.ti.com	Computers and Peripherals	www.ti.com/computers
Clocks and Timers	www.ti.com/clocks	Consumer Electronics	www.ti.com/consumer-apps
Interface	interface.ti.com	Energy	www.ti.com/energy
Logic	logic.ti.com	Industrial	www.ti.com/industrial
Power Mgmt	power.ti.com	Medical	www.ti.com/medical
Microcontrollers	microcontroller.ti.com	Security	www.ti.com/security
RFID	www.ti-rfid.com	Space, Avionics & Defense	www.ti.com/space-avionics-defense
RF/IF and ZigBee® Solutions	www.ti.com/lprf	Video and Imaging	www.ti.com/video
		Wireless	www.ti.com/wireless-apps

Mailing Address: Texas Instruments, Post Office Box 655303, Dallas, Texas 75265
Copyright © 2010, Texas Instruments Incorporated