

LM34917

Application Note 1601 LM34917A Evaluation Board



Literature Number: SNOA484C

LM34917A Evaluation Board

National Semiconductor
Application Note 1601
Dennis Morgan
April 10, 2008



Introduction

The LM34917AEVAL evaluation board provides the design engineer with a fully functional buck regulator, employing the constant on-time (COT) operating principle. This evaluation board provides a 5V output over an input range of 8V to 33V. The circuit delivers load currents to 1A, with current limit set at $\approx 1.3A$.

The board's specification are:

- Input Voltage: 8V to 33V
- Output Voltage: 5V
- Maximum load current: 1.0A
- Minimum load current: 0A
- Current Limit: $\approx 1.3A$
- Measured Efficiency: 91.6% ($V_{IN} = 8V, I_{OUT} = 400\text{ mA}$)
- Nominal Switching Frequency: 1.5 MHz
- Size: 2.6 in. x 1.6 in. x 0.5 in

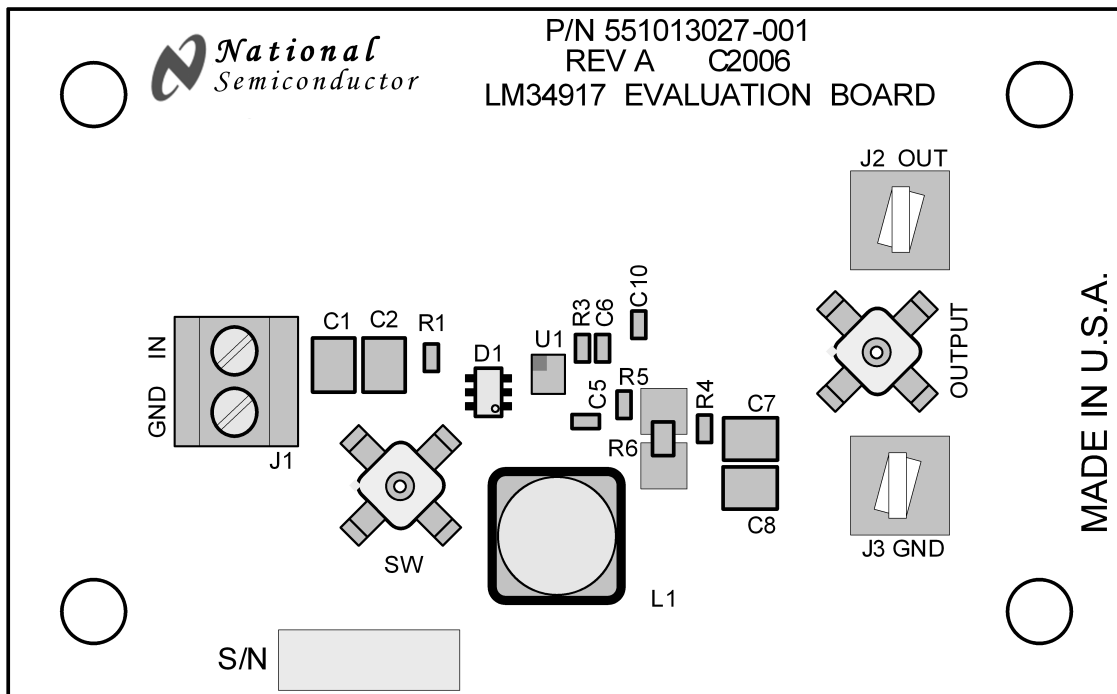

Note: R2, C3, C4 and C9 are located on board's back side.

30012801

FIGURE 1. Evaluation Board - Top Side

Theory of Operation

Refer to the evaluation board schematic in *Figure 2*, which contains a simplified block diagram of the LM34917A. When the circuit is in regulation, the buck switch is on each cycle for a time determined by R1 and V_{IN} according to the equation:

$$t_{ON} = \frac{1.16 \times 10^{-10} \times (R1 + 1.4 \text{ k}\Omega)}{V_{IN} - 1.35V} + 100 \text{ ns}$$

The on-time of this evaluation board ranges from ≈ 510 ns at $V_{IN} = 8V$, to ≈ 186 ns at $V_{IN} = 33V$. The on-time varies inversely with V_{IN} to maintain a nearly constant switching frequency. At the end of each on-time the Minimum Off-Timer

ensures the buck switch is off for at least 90 ns. In normal operation, the off-time is much longer. During the off-time, the load current is supplied by the output capacitor (C7, C8). When the output voltage falls sufficiently that the voltage at FB is below 2.5V, the regulation comparator initiates a new on-time period. For stable, fixed frequency operation, a minimum of 25 mV of ripple is required at FB to switch the regulation comparator. The current limit threshold, which varies with V_{in} , is $\approx 1.4A$ at $V_{in} = 8V$, and $\approx 1.2A$ at $V_{in} = 33V$. Refer to the LM34917A data sheet for a more detailed block diagram, and a complete description of the various functional blocks.

Board Layout and Probing

The pictorial in *Figure 1* shows the placement of the circuit components. The following should be kept in mind when the board is powered:

- 1) When operating at high input voltage and high load current, forced air flow may be necessary.
- 2) The LM34917A, and diode D1 may be hot to the touch when operating at high input voltage and high load current.
- 3) Use CAUTION when probing the circuit at high input voltages to prevent injury, as well as possible damage to the circuit.
- 4) At maximum load current (1A), the wire size and length used to connect the load becomes important. Ensure there is not a significant drop in the wires between this evaluation board and the load.

Board Connection/Start-Up

The input connections are made to the J1 connector. The load is connected to the J2 (OUT) and J3 (GND) terminals. Ensure the wires are adequately sized for the intended load current. Before start-up a voltmeter should be connected to the input terminals, and to the output terminals. The load current should be monitored with an ammeter or a current probe. It is recommended that the input voltage be increased gradually to 8V, at which time the output voltage should be 5V. If the output voltage is correct with 8V at VIN, then increase the input voltage as desired and proceed with evaluating the circuit. DO NOT EXCEED 50V AT VIN.

Output Ripple Control

The LM34917A requires a minimum of 25 mVp-p ripple at the FB pin, in phase with the switching waveform at the SW pin, for proper operation. The required ripple can be supplied from ripple at V_{OUT}, through the feedback resistors, as described in options B and C below, or the ripple can be generated separately (using R5, C9, C10) keeping the ripple at V_{OUT} to a minimum as described in option A below.

A) **Minimum Output Ripple:** This evaluation board is supplied configured for minimum ripple at V_{OUT} by using compo-

nents R5, C9 and C10. The output ripple, which ranges from $\approx 4\text{mVp-p}$ at $V_{IN} = 8\text{V}$ to $\approx 14\text{mVp-p}$ at $V_{IN} = 33\text{V}$, is determined primarily by the ESR of output capacitance, and the inductor's ripple current, which ranges from 105 mA_{p-p} to 350 mA_{p-p} over the input voltage range. The ripple voltage required by the FB pin is generated by R5, C9 and C10 since the SW pin switches from -1V to V_{IN}, and the right end of C10 is a virtual ground. The values for R5 and C10 are chosen to generate a 100 mVp-p triangle waveform at their junction. That triangle wave is then coupled to the FB pin through C9. The following procedure is used to calculate values for R5, C9 and C10:

- 1) Calculate the voltage V_A:

$$V_A = V_{OUT} - (V_{SW} \times (1 - (V_{OUT}/V_{IN})))$$

where V_{SW} is the absolute value of the voltage at the SW pin during the off-time (typically 1V), and V_{IN} is the minimum input voltage. For this circuit V_A calculates to 4.63V. This is the approximate DC voltage at the R5/C10 junction, and is used in the next equation.

- 2) Calculate the R5 x C10 product:

$$R5 \times C10 = \frac{(V_{IN} - V_A) \times t_{ON}}{\Delta V}$$

where t_{ON} is the maximum on-time ($\approx 510\text{ ns}$), V_{IN} is the minimum input voltage, and ΔV is the desired ripple amplitude at the R5/C10 junction, 100 mVp-p for this example.

$$R5 \times C10 = \frac{(8\text{V} - 4.63\text{V}) \times 510\text{ ns}}{0.1\text{V}} = 0.172 \times 10^{-4}$$

R5 and C10 are then chosen from standard value components to satisfy the above product. For example, C10 can be 3300 pF requiring R5 to be $\approx 5.2\text{ k}\Omega$. C9 is chosen to be 0.1 μF , large compared to C10. The circuit as supplied on this EVB is shown in *Figure 2*.

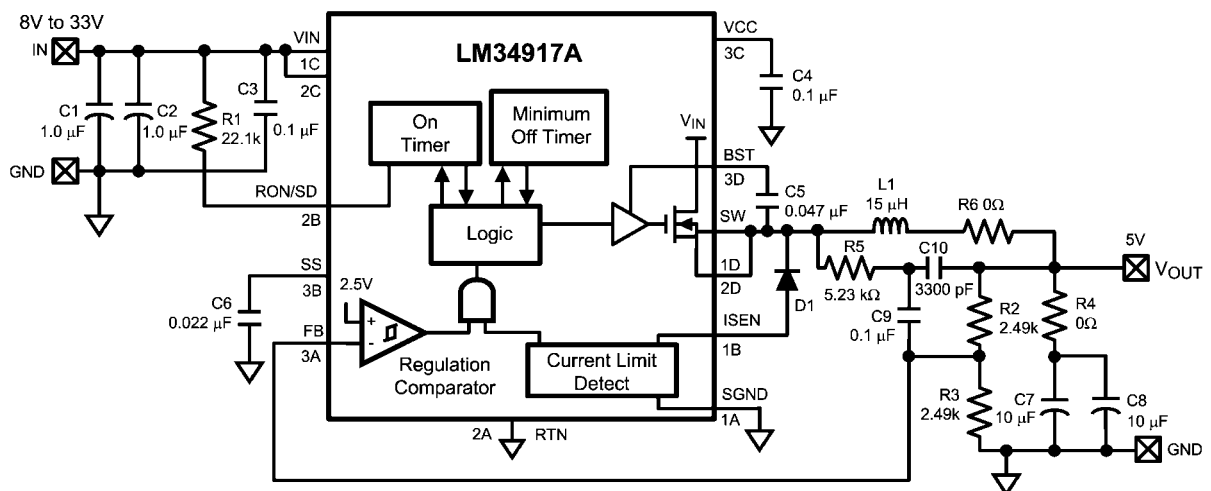

30012803

FIGURE 2. Minimum Output Ripple Configuration Using R5,C9,C10

B) Intermediate Ripple Level Configuration: This configuration generates more ripple at V_{OUT} than the above configuration, but uses one less capacitor. If some ripple can be

tolerated in the application, this configuration is slightly more economical, and simpler. R5, C9 and C10 are removed. R4 and Cff are added as shown in *Figure 3*.

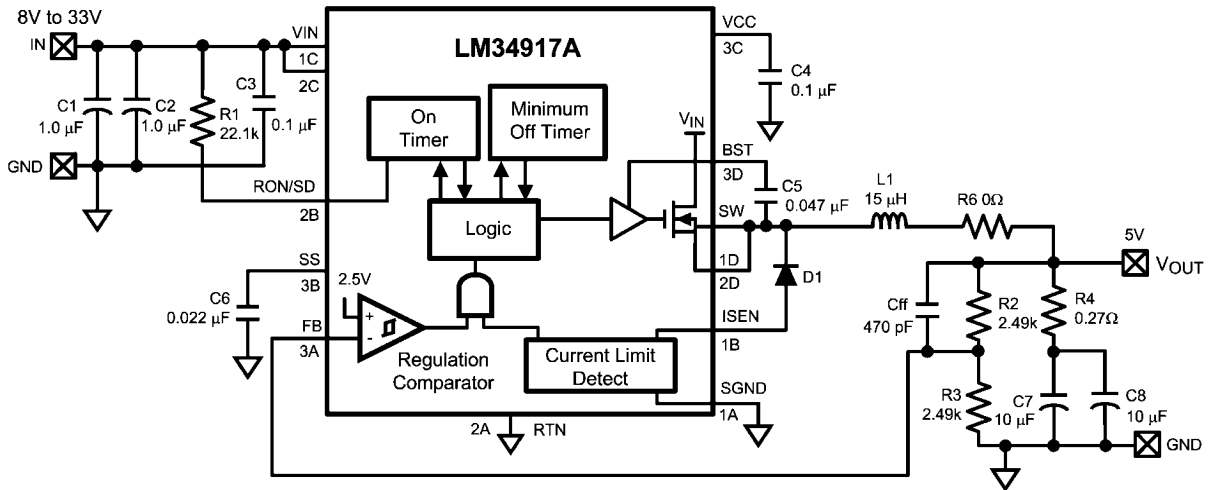

30012807

FIGURE 3. Intermediate Ripple Configuration Using Cff and R4

R4 is chosen to generate 25-30 mVp-p at V_{OUT} knowing that the minimum ripple current is 105 mA p-p at minimum V_{IN} . Cff couples that ripple to the FB pin without the attenuation of the feedback resistors. Cff's minimum value is calculated from:

$$C_{ff} = \frac{t_{ON(max)}}{(R2//R3)}$$

where $t_{ON(max)}$ is the maximum on-time (at minimum V_{IN}), and $R2//R3$ is the equivalent parallel value of the feedback resistors. For this evaluation board $t_{ON(max)}$ is approximately 510

ns, and $R2//R3 = 1.25 \text{ k}\Omega$, and Cff calculates to a minimum of 408 pF. In the circuit of *Figure 3* the ripple at V_{OUT} ranges from $\approx 32 \text{ mVp-p}$ to $\approx 84 \text{ mVp-p}$ over the input voltage range.

C) Lowest Cost Configuration: This configuration is the same as option B above, but without Cff. Since $\geq 25 \text{ mVp-p}$ are required at the FB pin, R4 is chosen to generate $\geq 50 \text{ mV}$ at V_{OUT} , knowing that the minimum ripple current in this circuit is 105 mA p-p at minimum V_{IN} . Using 0.5Ω for R4, the ripple at V_{OUT} ranges from $\approx 80 \text{ mVp-p}$ to $\approx 150 \text{ mVp-p}$ over the input voltage range. If the application can tolerate this ripple level, this is the most economical solution. The circuit is shown in *Figure 4*.

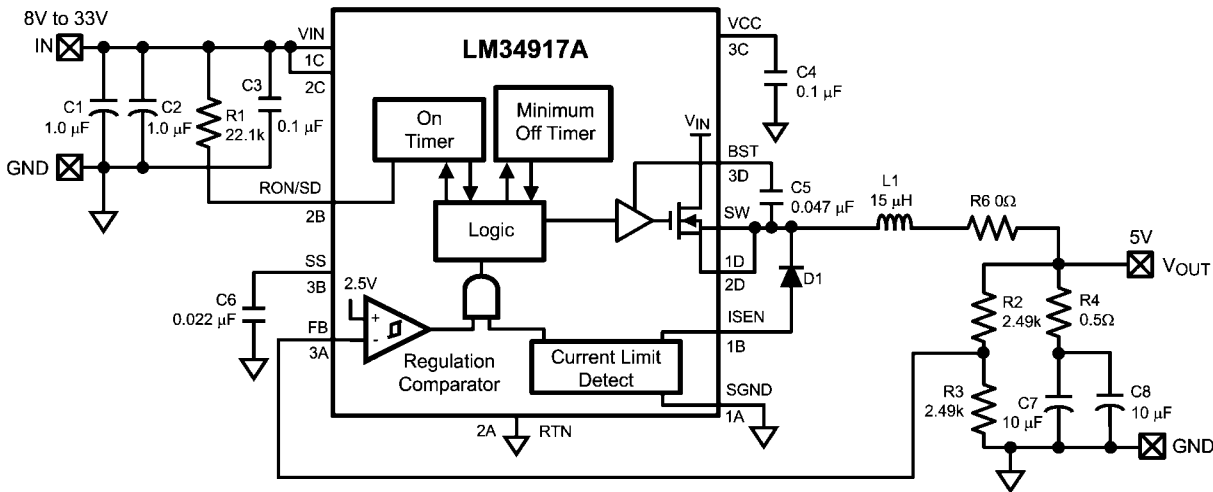

30012808

FIGURE 4. Lowest Cost Configuration

Monitor the Inductor Current

The inductor's current can be monitored or viewed on a scope with a current probe. Remove R6, and install an appropriate current loop across the two large pads where R6 was located. In this way the inductor's ripple current and peak current can be accurately determined.

Scope Probe Adapters

Scope probe adapters are provided on this evaluation board for monitoring the waveform at the SW pin, and at the circuit's

output (V_{OUT}), without using the probe's ground lead which can pick up noise from the switching waveforms. The probe adapters are suitable for Tektronix P6137 or similar probes, with a 0.135" diameter.

Minimum Load Current

The LM34917A requires a minimum load current of ≈ 1 mA to ensure the boost capacitor (C5) is recharged sufficiently during each off-time. In this evaluation board, the minimum load current is provided by the feedback resistors allowing the board's minimum load current at V_{OUT} to be specified at zero.

Bill of Materials

Item	Description	Mfg., Part Number	Package	Value
C1,2	Ceramic Capacitor	TDK C3216X7R1H105M	1206	1.0 μ F, 50V
C3	Ceramic Capacitor	TDK C1608X7R1H104K	0603	0.1 μ F, 50V
C4	Ceramic Capacitor	TDK C1608X7R1H104K	0603	0.1 μ F, 50V
C6	Ceramic Capacitor	TDK C1608X7R1H223K	0603	0.022 μ F, 50V
C5	Ceramic Capacitor	TDK C1608X7R1H473K	0603	0.047 μ F, 50V
C7, C8	Ceramic Capacitor	TDK C3216X7R1C106K	1206	10 μ F, 16V
C9	Ceramic Capacitor	TDK C1608X7R1H104K	0603	0.1 μ F, 50V
C10	Ceramic Capacitor	TDK C1608X7R1H332K	0603	3300 pF
D1	Schottky Diode	Zetex ZLLS2000	SOT23-6	40V, 2.2A
L1	Power Inductor	Bussman DR73-150	7.6 mm x 7.6 mm	15 μ H, 1.8A
R1	Resistor	Vishay CRCW06032212F	0603	22.1 k Ω
R2, R3	Resistor	Vishay CRCW06032491F	0603	2.49 k Ω
R4	Resistor	Vishay CRCW06030000Z	0603	0 Ω
R5	Resistor	Vishay CRCW06035231F	0603	5.23 k Ω
R6	Resistor	Vishay CRCW08050000Z	0805	0 Ω Jumper
U1	Switching Regulator	National Semiconductor LM34917ATL	12 Bump μ SMD	

Circuit Performance

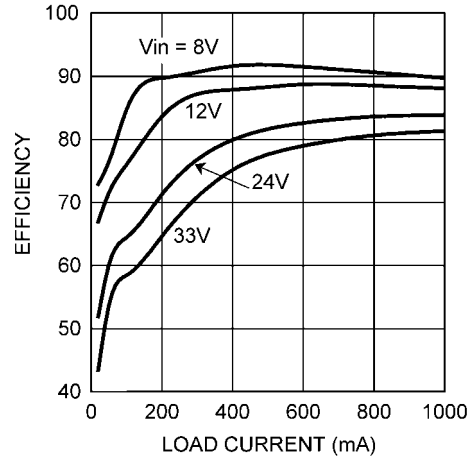

30012809

FIGURE 5. Efficiency vs Load Current

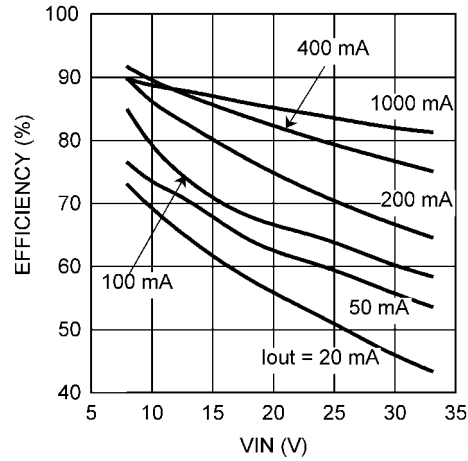

30012810

FIGURE 6. Efficiency vs Input Voltage

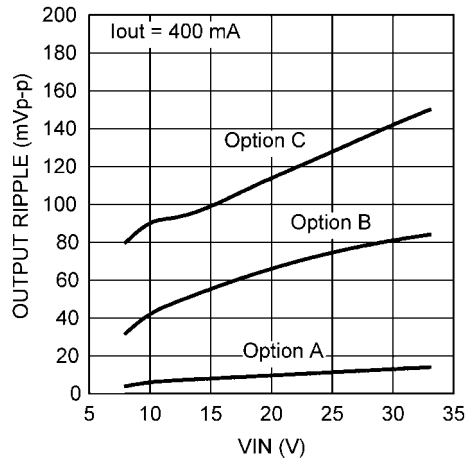

30012811

FIGURE 7. Output Voltage Ripple

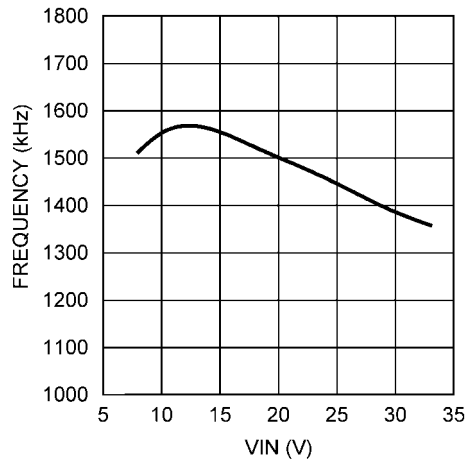

30012812

FIGURE 8. Switching Frequency vs. Input Voltage

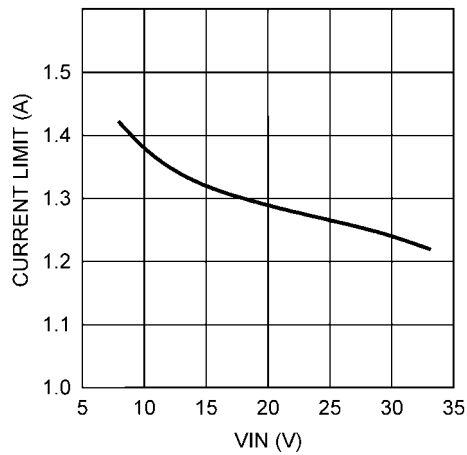

30012813

FIGURE 9. Current Limit vs Input Voltage

Typical Waveforms

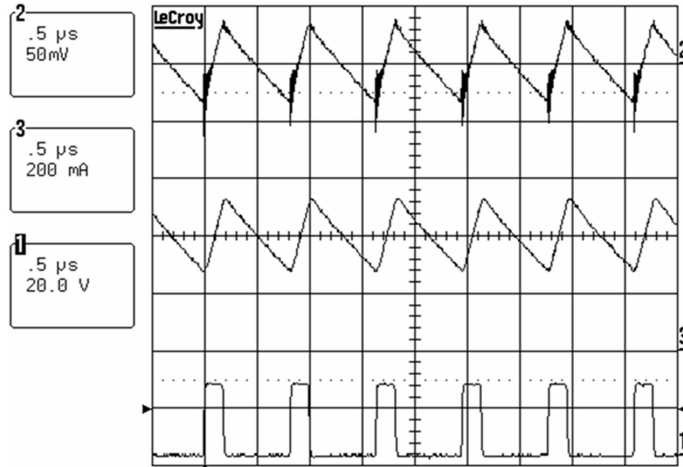

Trace 2 = Vout
 Trace 3 = Inductor Current
 Trace 1 = SW Pin
 Vin = 24V, Iout = 400 mA, Option B

30012814

FIGURE 10. Continuous Conduction Mode

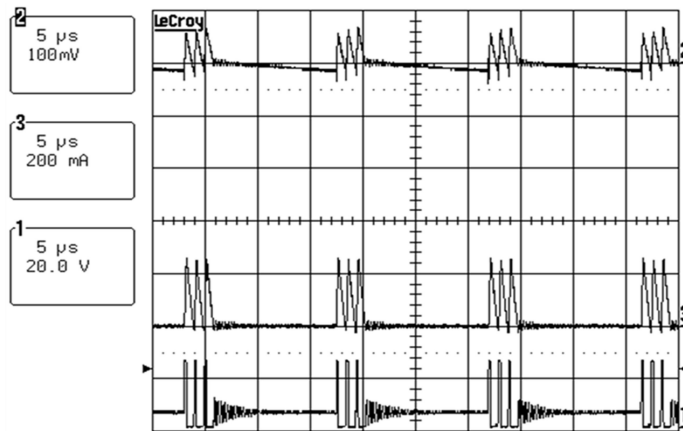

Trace 2 = Vout
 Trace 3 = Inductor Current
 Trace 1 = SW Pin
 Vin = 24V, Iout = 20 mA, Option B

30012815

FIGURE 11. Discontinuous Conduction Mode

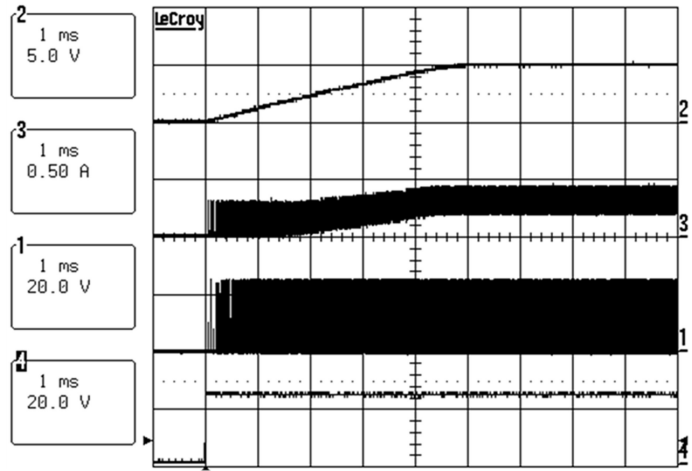

Trace 2 = Vout
Trace 3 = Inductor Current
Trace 1 = SW Pin
Trace 4 = Vin (0V to 24V)
Iout = 400 mA, Option B

30012816

FIGURE 12. Startup Waveforms

PC Board Layout

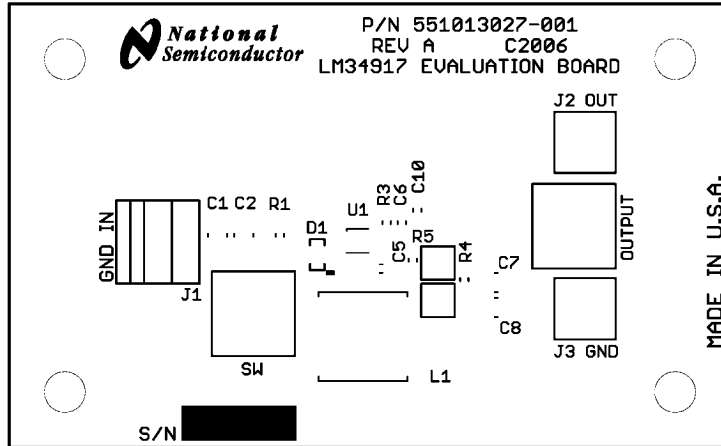

Board Silkscreen

30012817

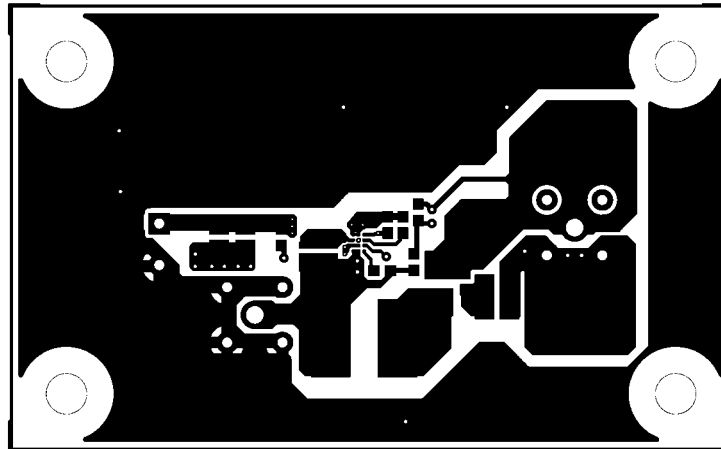

Board Top Layer

30012818

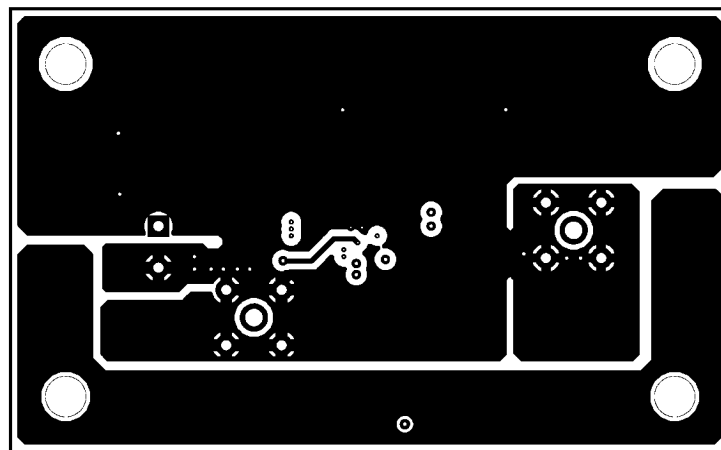

Board Second Layer (Viewed from Top)

30012819

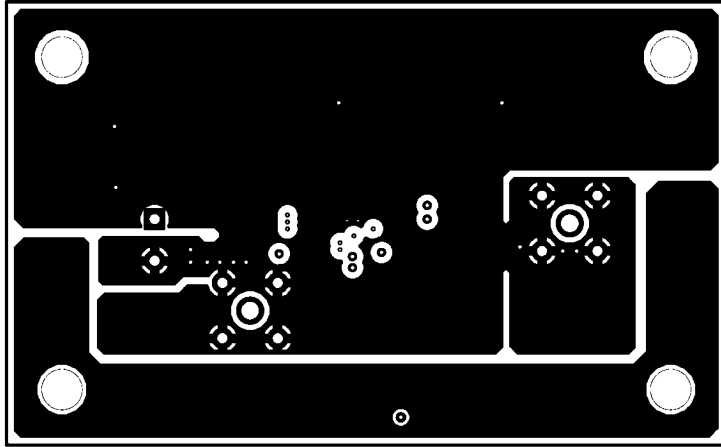

Board Third Layer (Viewed from Top)

30012820

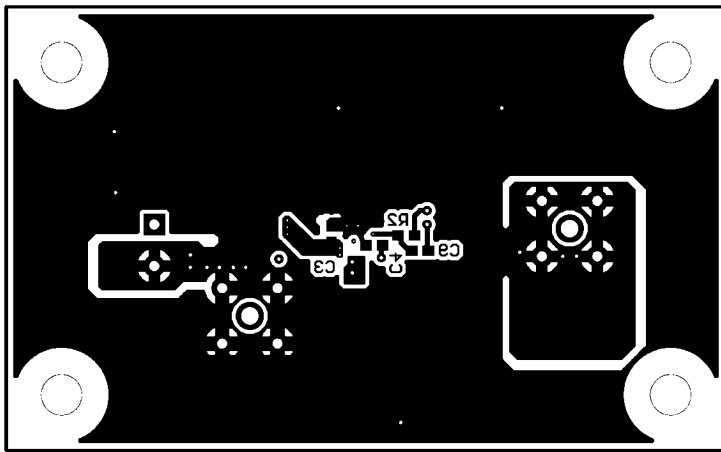

Board Bottom Layer (Viewed from Top)

30012821

Notes

AN-1601

Notes

For more National Semiconductor product information and proven design tools, visit the following Web sites at:

Products		Design Support	
Amplifiers	www.national.com/amplifiers	WEBENCH	www.national.com/webench
Audio	www.national.com/audio	Analog University	www.national.com/AU
Clock Conditioners	www.national.com/timing	App Notes	www.national.com/appnotes
Data Converters	www.national.com/adc	Distributors	www.national.com/contacts
Displays	www.national.com/displays	Green Compliance	www.national.com/quality/green
Ethernet	www.national.com/ethernet	Packaging	www.national.com/packaging
Interface	www.national.com/interface	Quality and Reliability	www.national.com/quality
LVDS	www.national.com/lvds	Reference Designs	www.national.com/refdesigns
Power Management	www.national.com/power	Feedback	www.national.com/feedback
Switching Regulators	www.national.com/switchers		
LDOs	www.national.com/lido		
LED Lighting	www.national.com/led		
PowerWise	www.national.com/powerwise		
Serial Digital Interface (SDI)	www.national.com/sdi		
Temperature Sensors	www.national.com/tempsensors		
Wireless (PLL/VCO)	www.national.com/wireless		

THE CONTENTS OF THIS DOCUMENT ARE PROVIDED IN CONNECTION WITH NATIONAL SEMICONDUCTOR CORPORATION ("NATIONAL") PRODUCTS. NATIONAL MAKES NO REPRESENTATIONS OR WARRANTIES WITH RESPECT TO THE ACCURACY OR COMPLETENESS OF THE CONTENTS OF THIS PUBLICATION AND RESERVES THE RIGHT TO MAKE CHANGES TO SPECIFICATIONS AND PRODUCT DESCRIPTIONS AT ANY TIME WITHOUT NOTICE. NO LICENSE, WHETHER EXPRESS, IMPLIED, ARISING BY ESTOPPEL OR OTHERWISE, TO ANY INTELLECTUAL PROPERTY RIGHTS IS GRANTED BY THIS DOCUMENT.

TESTING AND OTHER QUALITY CONTROLS ARE USED TO THE EXTENT NATIONAL DEEMS NECESSARY TO SUPPORT NATIONAL'S PRODUCT WARRANTY. EXCEPT WHERE MANDATED BY GOVERNMENT REQUIREMENTS, TESTING OF ALL PARAMETERS OF EACH PRODUCT IS NOT NECESSARILY PERFORMED. NATIONAL ASSUMES NO LIABILITY FOR APPLICATIONS ASSISTANCE OR BUYER PRODUCT DESIGN. BUYERS ARE RESPONSIBLE FOR THEIR PRODUCTS AND APPLICATIONS USING NATIONAL COMPONENTS. PRIOR TO USING OR DISTRIBUTING ANY PRODUCTS THAT INCLUDE NATIONAL COMPONENTS, BUYERS SHOULD PROVIDE ADEQUATE DESIGN, TESTING AND OPERATING SAFEGUARDS.

EXCEPT AS PROVIDED IN NATIONAL'S TERMS AND CONDITIONS OF SALE FOR SUCH PRODUCTS, NATIONAL ASSUMES NO LIABILITY WHATSOEVER, AND NATIONAL DISCLAIMS ANY EXPRESS OR IMPLIED WARRANTY RELATING TO THE SALE AND/OR USE OF NATIONAL PRODUCTS INCLUDING LIABILITY OR WARRANTIES RELATING TO FITNESS FOR A PARTICULAR PURPOSE, MERCHANTABILITY, OR INFRINGEMENT OF ANY PATENT, COPYRIGHT OR OTHER INTELLECTUAL PROPERTY RIGHT.

LIFE SUPPORT POLICY

NATIONAL'S PRODUCTS ARE NOT AUTHORIZED FOR USE AS CRITICAL COMPONENTS IN LIFE SUPPORT DEVICES OR SYSTEMS WITHOUT THE EXPRESS PRIOR WRITTEN APPROVAL OF THE CHIEF EXECUTIVE OFFICER AND GENERAL COUNSEL OF NATIONAL SEMICONDUCTOR CORPORATION. As used herein:

Life support devices or systems are devices which (a) are intended for surgical implant into the body, or (b) support or sustain life and whose failure to perform when properly used in accordance with instructions for use provided in the labeling can be reasonably expected to result in a significant injury to the user. A critical component is any component in a life support device or system whose failure to perform can be reasonably expected to cause the failure of the life support device or system or to affect its safety or effectiveness.

National Semiconductor and the National Semiconductor logo are registered trademarks of National Semiconductor Corporation. All other brand or product names may be trademarks or registered trademarks of their respective holders.

Copyright© 2008 National Semiconductor Corporation

For the most current product information visit us at www.national.com



**National Semiconductor
Americas Technical
Support Center**
Email:
new.feedback@nsc.com
Tel: 1-800-272-9959

**National Semiconductor Europe
Technical Support Center**
Email: europe.support@nsc.com
German Tel: +49 (0) 180 5010 771
English Tel: +44 (0) 870 850 4288

**National Semiconductor Asia
Pacific Technical Support Center**
Email: ap.support@nsc.com

**National Semiconductor Japan
Technical Support Center**
Email: jpn.feedback@nsc.com

IMPORTANT NOTICE

Texas Instruments Incorporated and its subsidiaries (TI) reserve the right to make corrections, modifications, enhancements, improvements, and other changes to its products and services at any time and to discontinue any product or service without notice. Customers should obtain the latest relevant information before placing orders and should verify that such information is current and complete. All products are sold subject to TI's terms and conditions of sale supplied at the time of order acknowledgment.

TI warrants performance of its hardware products to the specifications applicable at the time of sale in accordance with TI's standard warranty. Testing and other quality control techniques are used to the extent TI deems necessary to support this warranty. Except where mandated by government requirements, testing of all parameters of each product is not necessarily performed.

TI assumes no liability for applications assistance or customer product design. Customers are responsible for their products and applications using TI components. To minimize the risks associated with customer products and applications, customers should provide adequate design and operating safeguards.

TI does not warrant or represent that any license, either express or implied, is granted under any TI patent right, copyright, mask work right, or other TI intellectual property right relating to any combination, machine, or process in which TI products or services are used. Information published by TI regarding third-party products or services does not constitute a license from TI to use such products or services or a warranty or endorsement thereof. Use of such information may require a license from a third party under the patents or other intellectual property of the third party, or a license from TI under the patents or other intellectual property of TI.

Reproduction of TI information in TI data books or data sheets is permissible only if reproduction is without alteration and is accompanied by all associated warranties, conditions, limitations, and notices. Reproduction of this information with alteration is an unfair and deceptive business practice. TI is not responsible or liable for such altered documentation. Information of third parties may be subject to additional restrictions.

Resale of TI products or services with statements different from or beyond the parameters stated by TI for that product or service voids all express and any implied warranties for the associated TI product or service and is an unfair and deceptive business practice. TI is not responsible or liable for any such statements.

TI products are not authorized for use in safety-critical applications (such as life support) where a failure of the TI product would reasonably be expected to cause severe personal injury or death, unless officers of the parties have executed an agreement specifically governing such use. Buyers represent that they have all necessary expertise in the safety and regulatory ramifications of their applications, and acknowledge and agree that they are solely responsible for all legal, regulatory and safety-related requirements concerning their products and any use of TI products in such safety-critical applications, notwithstanding any applications-related information or support that may be provided by TI. Further, Buyers must fully indemnify TI and its representatives against any damages arising out of the use of TI products in such safety-critical applications.

TI products are neither designed nor intended for use in military/aerospace applications or environments unless the TI products are specifically designated by TI as military-grade or "enhanced plastic." Only products designated by TI as military-grade meet military specifications. Buyers acknowledge and agree that any such use of TI products which TI has not designated as military-grade is solely at the Buyer's risk, and that they are solely responsible for compliance with all legal and regulatory requirements in connection with such use.

TI products are neither designed nor intended for use in automotive applications or environments unless the specific TI products are designated by TI as compliant with ISO/TS 16949 requirements. Buyers acknowledge and agree that, if they use any non-designated products in automotive applications, TI will not be responsible for any failure to meet such requirements.

Following are URLs where you can obtain information on other Texas Instruments products and application solutions:

Products

Audio	www.ti.com/audio
Amplifiers	amplifier.ti.com
Data Converters	dataconverter.ti.com
DLP® Products	www.dlp.com
DSP	dsp.ti.com
Clocks and Timers	www.ti.com/clocks
Interface	interface.ti.com
Logic	logic.ti.com
Power Mgmt	power.ti.com
Microcontrollers	microcontroller.ti.com
RFID	www.ti-rfid.com
OMAP Mobile Processors	www.ti.com/omap
Wireless Connectivity	www.ti.com/wirelessconnectivity

Applications

Communications and Telecom	www.ti.com/communications
Computers and Peripherals	www.ti.com/computers
Consumer Electronics	www.ti.com/consumer-apps
Energy and Lighting	www.ti.com/energy
Industrial	www.ti.com/industrial
Medical	www.ti.com/medical
Security	www.ti.com/security
Space, Avionics and Defense	www.ti.com/space-avionics-defense
Transportation and Automotive	www.ti.com/automotive
Video and Imaging	www.ti.com/video

TI E2E Community Home Page

e2e.ti.com

Mailing Address: Texas Instruments, Post Office Box 655303, Dallas, Texas 75265
Copyright © 2011, Texas Instruments Incorporated