



## **Si9181DB/Si9182DB Demonstration Board**

### **FEATURES**

- 2-V to 6-V Input Voltages Range
- Uses Low-ESR Ceramic Capacitors At The Input and Output
- Fast Load and Line Transient Response
  - On Board Load Transient Response Test Circuit
- 100- $\mu$ Vrms Noise With Noise Bypass Capacitor
  - Probe Clip Provision For Accurate Noise Measurement
- 1- $\mu$ A Maximum Shutdown Current.
- Built In Short Circuit and Thermal Protection
- Out of Regulation Error Flag
- Fixed 1.5-V, 1.8-V, 2.0-V, 2.5-V, 2.8-V, 3.0-V, 3.8-V, 5.0-V, Or Adjustable Voltage Versions Available
- Provision To Measure The Ground Current
- Si9181—Low 150-mV Dropout At 350-mA Load
  - 500-mA Peak Current Capability
  - TSSOP-8 Package With 833-mW Power Dissipation
- Si9182—Low 105 mV Dropout At 250-mA Load
  - 500-mA Peak Current Capability
  - Space Saving MSOP-8 Package With 666-mW Power Dissipation

### **DESCRIPTION**

The Si9181DQ/Si9182DH are the extremely low drop CMOS linear regulator ICs operating from 2-V to 6-V input. These devices offer ultra-low ground current and low dropout to extend the battery life in portable electronics.

The demo boards are designed to verify different features easily and quickly. The input and output capacitors are selected to meet the specified noise and transient requirement. The device features the use of low ESR, low cost multi-layer ceramic capacitors. The Si9181DB/Si9182DB are provided with a MOSFET switch along with other components to measure the load transient response. The slew-rate of the

switching load can be adjusted easily to simulate the actual load conditions. Provisions are made to measure the ground current and output noise accurately.

The demonstration board uses surface mount and through-hole components and is fully assembled and tested for quick evaluation. The test points are provided for the closed-loop response measurement.

Included in this document are the Bill-Of-Materials, Schematics, PCB Layout of the Demo Boards and actual waveforms/graphs.

*The demonstration board layout is available in Gerber file format. Please contact your Vishay Siliconix sales representative or distributor for a copy.*

**ORDERING INFORMATION: Si9181DB or Si9182DB**

### POWER UP CHECK LIST AND OPERATION

Visually inspect the PCB to be sure that all the components are intact and no foreign substance is lying on the board.

- 1 Insert jumper JP2 and remove jumper JP3.
- 2 Insert JP1 to EN position.
- 3 Load the output to the rated load current.
- 4 Increase the input from 0 V slowly, while monitoring the output. Note the regulated output voltage.
- 5 Increase the input to 6 V and check the line regulation. Vary the load from 0 to 350 mA (Si9181DB) and 0 to 250 mA (Si9182DB) and check the load regulation.
- 6 Follow the "Typical Waveforms and Performance" to verify the dropout, transient response ground current and output noise.

### DROPOUT VOLTAGE

The dropout voltage is defined as the input to output voltage differential measured, when the output drops by 100 mV from its normal value. The output voltage is nominal at  $V_{IN}$  equal to  $V_{OUT} + 1$ . The dropout voltage is different at different output. Plots in Figure 1 and Figure 3 show the typical dropouts measured on bench at 25°C ambient temperature.

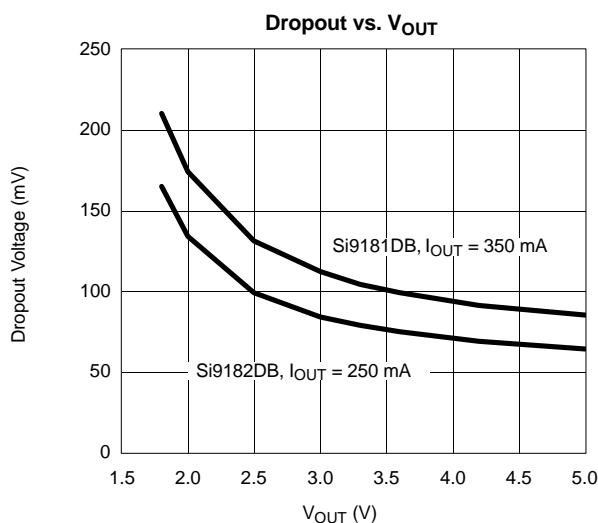


FIGURE 1. Dropout Voltage Si9181DB/Si9182DB

### LOAD TRANSIENT RESPONSE

The Si9181DB and Si9182DB are provided with additional circuit to measure the load step response from 1 to 150 mA with 2- $\mu$ Sec load rise/fall times. The load step and slew-rate can be easily changed by selecting R4, R5, R7 and R8.

Remove the external load from the output, insert the jumper JP3 and apply 5- $V_{pk-pk}$ /5-kHz square wave signal at P5 (TRAN). Remove the oscilloscope probe-cap and insert the probe into the probe-clip. Set the oscilloscope to 10 mV/div and 5- $\mu$ Sec/div. Refer to Figures 3 through 5 for typical load transient waveform.

### GROUND CURRENT

Remove the jumper JP2 and insert micro-ampere meter. Use thick and short wires to connect the meter. Vary the load to measure the ground current at all loads. (See Figure 2.)

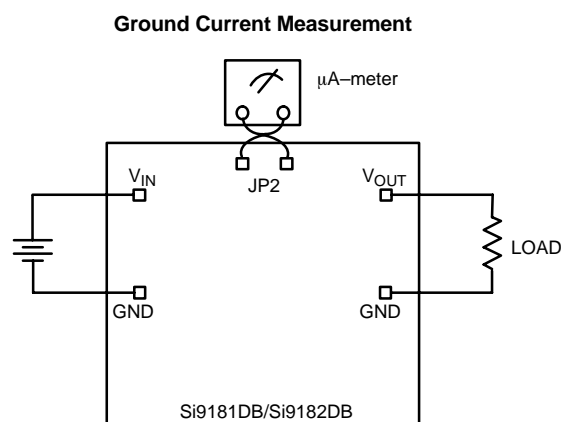


FIGURE 2. Ground Current Measurement

### TYPICAL WAVEFORMS

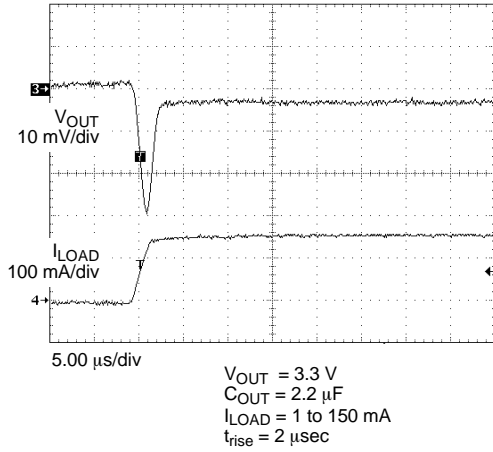


FIGURE 3. Load Transient Response-1 (Si9181DB)

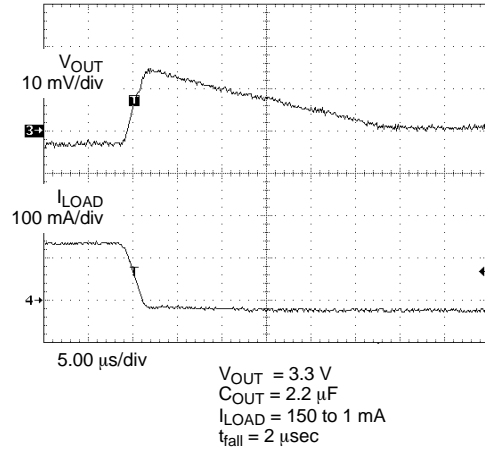


FIGURE 4. Load Transient Response-2 (Si9181DB)

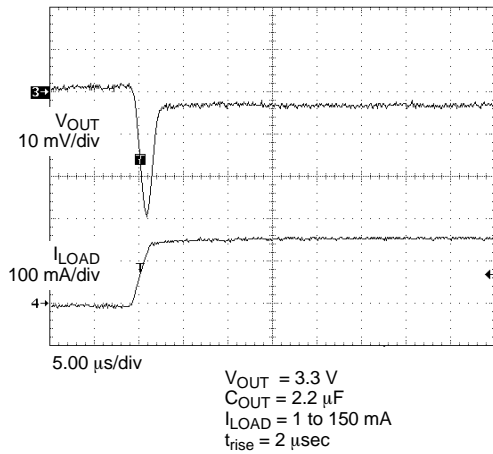


FIGURE 5. Load Transient Response-1 (Si9182DB)

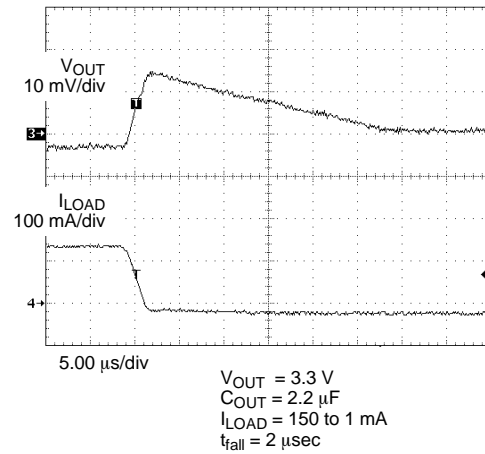
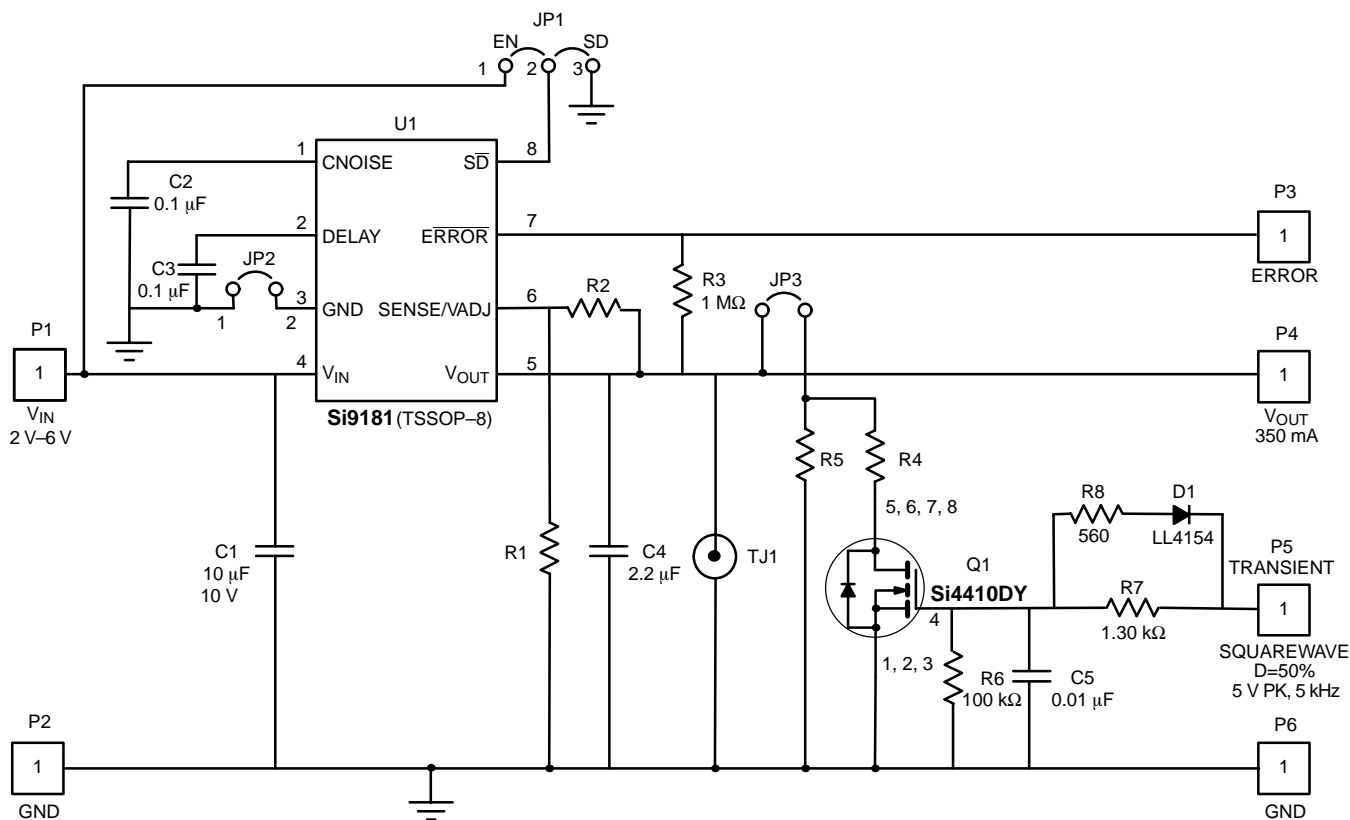


FIGURE 6. Load Transient Response-2 (Si9182DB)

### SCHEMATIC, PCB LAYOUT AND BILL-OF-MATERIAL (Si9181)



LDO Version	Output	R1	R2	R4	R5
A	Adjustable	124 k	TBD	TBD	TBD
B	2.0 V	Open	0	13.5	2.0 k
C	2.5 V	Open	0	16.9	2.49 k
D	3.0 V	Open	0	20.0	3.01 k
E	3.3 V	Open	0	22.1	3.32 k
F	5.0 V	Open	0	33.5	4.99 k
G	1.8 V	Open	0	12.1	1.82 k

FIGURE 7. Demo Board—Si9181

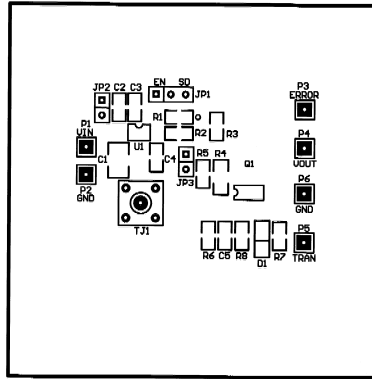


FIGURE 8. Silk Screen—Si9181

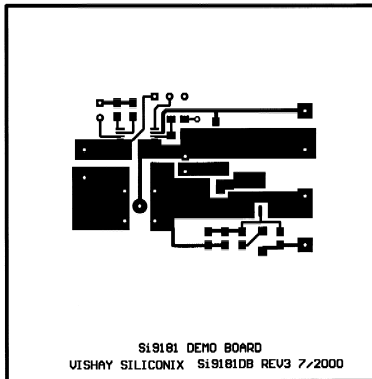


FIGURE 9. Top Layer—Si9181

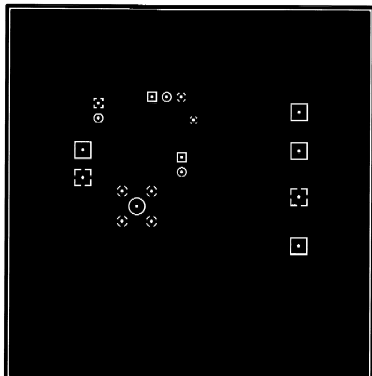


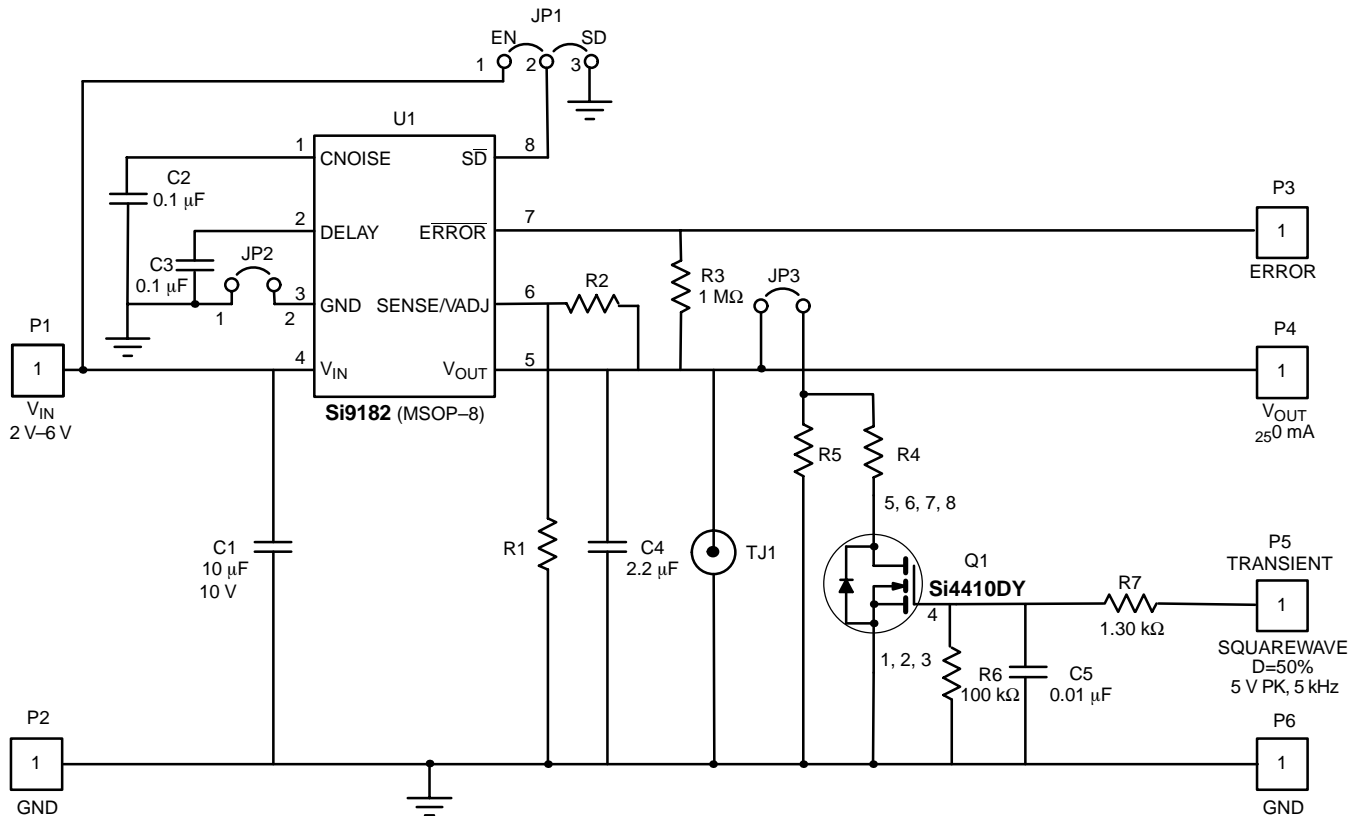
FIGURE 10. Bottom Layer—Si9181

**BILL-OF-MATERIALS—SI9181**

Item	Qty	Designator	Part Type	Description	Footprint	Vendor Part #	Manufacturer
1	1	R1	See Figure 7	RES, 1%, 1/8 W	0805	CRCW0805xxxxFRT1	Vishay Dale
2	1	R2	See Figure 7	RES, 1%, 1/8 W	0805	CRCW08051004FRT1	Vishay Dale
3	1	R3	1 M	RES, 1%, 1/8 W	0805	CRCW0805xxxxFRT1	Vishay Dale
4	1	R4	See Figure 7	RES, 1%, 1/4 W	1206	CRCW0805xxxxFRT1	Vishay Dale
5	1	R5	See Figure 7	RES, 1%, 1/8 W	0805	CRCW0805xxxxFRT1	Vishay Dale
6	1	R6	100 k	RES, 1%, 1/8 W	0805	CRCW08051003FRT1	Vishay Dale
7	1	R7	1.30 k	RES, 1%, 1/8 W	0805	CRCW08051301FRT1	Vishay Dale
8	1	R8	560	RES, 1%, 1/8 W	0805	CRCW08055600FRT1	Vishay Dale
9	1	C1	10 $\mu$ F	CAP, CER, X5R, 10 V, 10%	1210	GRM42-2 X5R 106K 10	Murata
10	2	C2, C3	0.1 $\mu$ F	CAP, CER, X7R, 50 V, 10%	0805	VJ0805Y104KXAAT	Vishay Vitramon
11	1	C4	2.2 $\mu$ F	CAP, CER, X5R, 6.3 V, 10%	0805	GRM40X5R225K6.3	Murata
12	1	C5	0.01 $\mu$ F	CAP, CER, X7R, 50 V, 10%	0805	VJ0805Y102KXAAT	Vishay Vitramon
13	1	Q1	Si4410DY	N-MOSFET, 30 V	SO-8	Si4410DY	Vishay Siliconix
14	1	U1	Si9181	Power IC	TSSOP-8	Si9181	Vishay Siliconix
15	1	D1	LL4154	Diode, 35 V, 150 mA	MINIMELF	LL4154	VISHAY LITEON
16	1	TJ1	Test Jack	For 0.135' Dia Probe	TJ	131-4244-00	Jensen
17	1	JP1	Jumper	3-Pin Header	SIP3		Multi-Source
18	2	JP2, JP3	Jumper	2-Pin Header	SIP2		Multi-Source
19	6	P1 TO P6	Power, GND, TP	1-Pin Header	TP1	6821-0-00-01-00-00-08-0	Bisco Industries

\*Refer to Si9181 Schematic, Figure 7.

**SCHEMATIC, PCB LAYOUT AND BILL-OF-MATERIAL (Si9182)**



LDO Version	Output	R1	R2	R4	R5
A	Adjustable	124 k	TBD	TBD	TBD
B	2.0 V	Open	0	13.5	2.0 k
C	2.5 V	Open	0	16.9	2.49 k
D	3.0 V	Open	0	20.0	3.01 k
E	3.3 V	Open	0	22.1	3.32 k
F	5.0 V	Open	0	33.5	4.99 k
G	1.8 V	Open	0	12.1	1.82 k

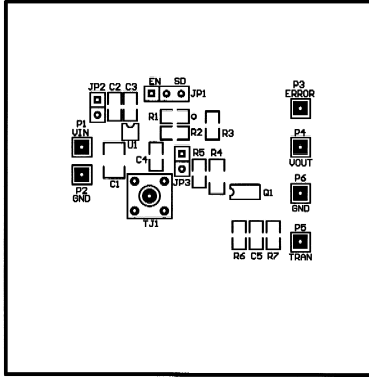
FIGURE 11. Demo Board—Si9182

**BILL-OF-MATERIALS—Si9182**

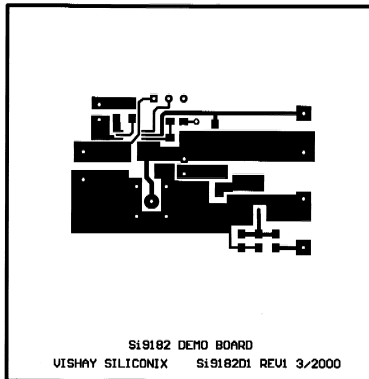
Item	Qty	Designator	Part Type	Description	Footprint	Vendor Part #	Manufacturer
1	1	R1	See Figure 11	RES, 1%, 1/8 W	0805	CRCW0805xxxxFRT1	Vishay Dale
2	1	R2	See Figure 11	RES, 1%, 1/8 W	0805	CRCW0805xxxxFRT1	Vishay Dale
3	1	R3	1 M	RES, 1%, 1/8 W	0805	CRCW08051005FRT1	Vishay Dale
4	1	R4	See Figure 11	RES, 1%, 1/4 W	1206	CRCW0805xxxxFRT1	Vishay Dale
5	1	R5	See Figure 11	RES, 1%, 1/8 W	0805	CRCW0805xxxxFRT1	Vishay Dale
6	1	R6	100 k	RES, 1%, 1/8 W	0805	CRCW08051003FRT1	Vishay Dale
7	1	R7	1.30 k	RES, 1%, 1/8 W	0805	CRCW08051301FRT1	Vishay Dale
8	1	C1	10 $\mu$ F	CAP, CER, X5R, 10 V, 10%	1210	GRM42-2X5R106K10	Murata
9	2	C2, C3	0.1 $\mu$ F	CAP, CER, X7R, 50 V, 10%	0805	VJ0805Y104KXAAT	Vishay Vitramon
10	1	C4	2.2 $\mu$ F	CAP, CER, X5R, 6.3 V, 10%	0805	GRM40X5R225K6.3	Murata
11	1	C5	0.01 $\mu$ F	CAP, CER, X7R, 50 V, 10%	0805	VJ0805Y102KXAAT	Vishay Vitramon
12	1	Q1	Si4410DY	N-MOSFET, 30 V	SO-8	Si4410DY	Vishay Siliconix
13	1	U1	Si9182	300 mA LDO	MSOP-8	Si9182	Vishay Siliconix
14	1	TJ1	Test Jack	For 0.135" Dia Probe	TJ	131-4244-00	Jensen
15	1	JP1	Jumper	3-Pin Header	SIP3		Multi-Source
16	2	JP2, JP3	Jumper	2-Pin Header	SIP2		Multi-Source
17	6	P1 to P6	Power, GND, TP	1-Pin Header	TP1	6821-0-00-01-00-00-08-0	Multi-Source

\*Refer to Si9182 Schematic, Figure 11.

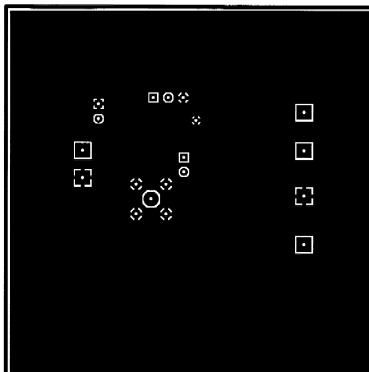




**FIGURE 12.** Silk Screen—Si9182



**FIGURE 13.** Top Layer—Si9182



**FIGURE 14.** Bottom Layer—Si9182