



Z8F16800144ZCOG

**Z8 Encore! XP[®] Dual F1680
Series Development Kit**

User Manual

UM021204-0508



Revision History

Each instance in Revision History reflects a change to this document from its previous revision. For more details, refer to the corresponding pages and appropriate links in the table below.

Date	Revision Level	Description	Page No
May 2008	04	Updated Introduction section.	1
February 2008	03	Updated Zilog logo and changed ZiLOG to Zilog.	All
June 2007	02	Removed IrDA.	2, 6, 8, 10
November 2006	01	Original issue.	All



Table of Contents

Introduction	1
MCU Features	1
Hardware-Supported Software Features	3
Z8 Encore! XP[®] Dual F1680 Series Development Board	4
Theory of Operation	5
Block Diagram	7
Hardware Interface Specification	8
Power and Communication Interfaces	8
External Interface Headers JP1 and JP2	9
Kit Contents	9
Installation	9
Schematics	10
Customer Support	14

Introduction

Zilog's Z8 Encore! XP[®] F1680 Series microcontrollers (MCU) are based on the 8-bit eZ8 CPU core and optimized for low-power applications. The Z8 Encore! XP F1680 Series support 1.8 V to 3.6 V operation with extremely low Active, Halt, and Stop mode currents and an assortment of speed and low power options. Z8F1680AN020 is the silicon used in the board. For more information, refer to *Z8 Encore! XP[®] F1680 Series Product Specification (PS0250)*. The features to balance power and performance needs of applications include:

- Wide operating voltage range: 1.8 V–3.6 V.
- Active, Halt, and Stop operational modes with the ability to enable or disable peripherals for power savings.
- Oscillator control that determines clock source, operating speed, and fail safe operation in addition to fast wakeup.
- A user-controlled Program RAM area to store interrupt service routines (ISR) of high-frequency interrupts. The Program RAM mechanism ensures low average current and quick response for high-frequency interrupts.

MCU Features

Features of the Z8 Encore! XP F1680 MCU include:

- Two Z8F1680AN020SG 44-pin Devices with 20 MHz eZ8 CPU core
- 16 KB Flash memory with in-circuit programming capability
- 2 KB register data RAM
- 1 KB Program RAM for program code shadowing and data storage
- 256 B non-volatile data storage (NVDS)

- Fast 8-channel, 10-bit analog-to-digital converter (ADC)
- On-chip temperature sensor
- Two on-chip analog comparators
- On-chip low-power operational amplifier (LPO)
- Two full-duplex, 9-bit, UART ports with support of Local Interconnect Network (LIN) protocol
- Enhanced serial peripheral interface (SPI) controller
- I²C Master/Slave
- Three enhanced 16-bit timers with Capture, Compare, and PWM capability
- Multichannel timer that supports four capture/compare modules on one timer
- Watchdog Timer (WDT) with dedicated internal RC oscillator
- 39 Input/Output (I/O) pins
- Up to 20 vectored interrupts
- On-Chip Debugger (OCD)
- Power-On Reset (POR)
- Built-in Low-Voltage Detection (LVD) and Voltage Brownout (VBO) protection
- Internal Precision Oscillator (IPO) with output frequency range of 43 kHz to 11 MHz
- External 20 MHz Crystal oscillator
- Operational voltage: 3.3 V
- Thirty-nine 5 V-tolerant inputs (DIGITAL mode only)
- 0 °C to +70 °C (standard) operating temperature ranges

For more information on the Z8 Encore! XP F1680 Series, refer to *Z8 Encore! XP[®] F1680 Series Product Specification (PS0250)*, available for download at www.zilog.com.

Hardware-Supported Software Features

Zilog's eZ8 MCU, latest 8-bit MCU meets the continuing demand for faster and more code-efficient microcontrollers. It executes a superset of the original Z8[®] instruction set. The eZ8 MCU features include:

- Direct register-to-register architecture allows each register to function as an accumulator, improving execution time and decreasing the required Program Memory.
- Software stack allows greater depth in sub-routine calls and interrupts more than hardware stacks.
- Compatible with existing Z8 code.
- Expanded internal Register File allows access up to 4 KB.
- New instructions improve execution efficiency for code developed using higher-level programming languages including C.
- Pipelined instruction fetch and execution.
- New instructions for improved performance including BIT, BSWAP, BTJ, CPC, LDC, LDCI, LEA, MULT, and SRL.
- New instructions support 12-bit linear addressing of the register file.
- Up to 10 MIPS operation.
- C-Compiler friendly.
- 2 to 9 clock cycles per instruction.

For more details on eZ8 MCU, refer to *eZ8[™] CPU User Manual (UM0128)*, available for download at www.zilog.com.

Theory of Operation

Figure 2 displays the Z8 Encore! XP F1680 development board.

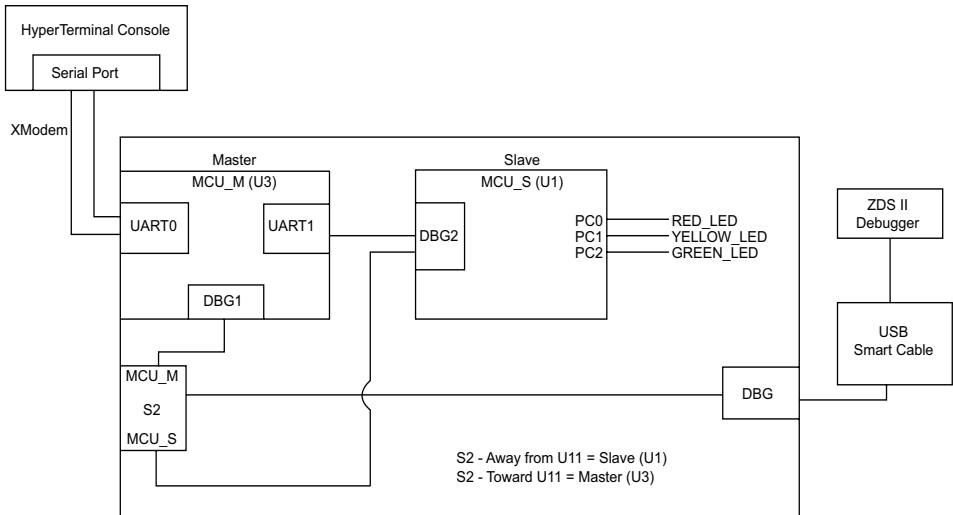

Figure 2. Z8 Encore! XP F1680 Development Board

The terms used in this section are explained below:

Terms	Definitions
Z8F1680_S (MCU_S)	I ² C Slave device
Z8F1680_M (MCU_M)	I ² C Master device

The features of Z8F1680 MDS-compliant module include:

- Two Z8F1680 devices: the Z8F1680_M I²C Master device and the Z8F1680_S I²C Slave device.

- RS-232 interface.
- Two MDS connectors.
- I²C-driven DAC that provides analog input for the Z8F1680_S device.
- The Slave device has a 20 MHz crystal; the Master device uses internal IPO.
- On-chip debugger interface.

The module has two main modes of operation:

- Downloading and debugging code into the Slave device through the Master device, using the connection of the OCD of the Slave device to the UART1 of the Master device. In this case, PA7 of the Master device is acting as a Reset source for the Slave device and needs to be configured as an output with Open Drain.
- Downloading and debugging code in either the Master or Slave device using the standard OCD interface on either chip.

The operation mode is selected by switch S2.

All the GPIOs of both devices, except for those used on the module are connected to JP1 and JP2. All the GPIOs of the Slave device, except analog inputs are connected to the odd pins of JP1. The GPIOs of the Master device are connected to the even pins of JP1 and to JP2. All the analog inputs of the Slave device are connected to JP2. Input PB3/ANA3 of the Slave device can be connected through J1 to either the output of U2 (12-bit DAC) or to JP2 pin 6.

The 12-bit DAC7571 manufactured by TI (U2) is controlled either by Master or Slave device.

Block Diagram

Figure 3 displays the block diagram of the Z8F1680 MDS module.

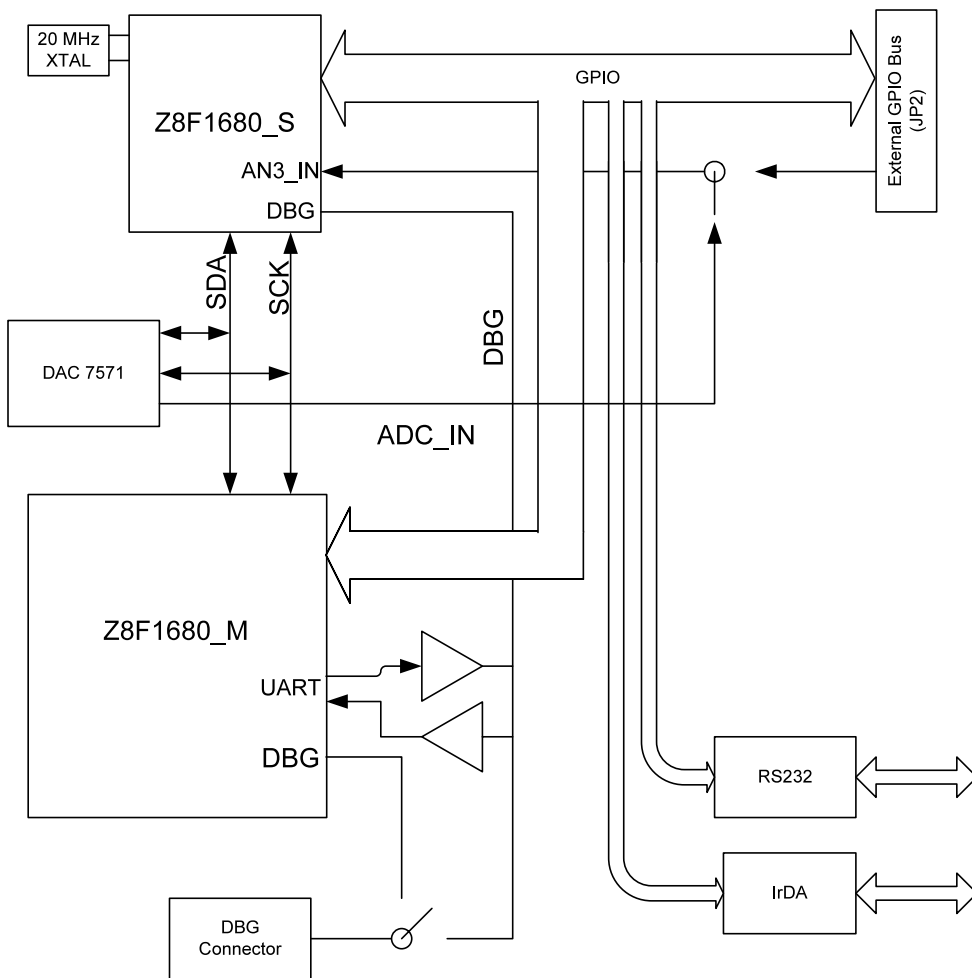

Figure 3. Block Diagram of the Z8F1680 MDS Module

Hardware Interface Specification

The hardware specifications include:

- Headers
- Drivers (I²C, UART, and so on)
- Debug interface
- Expansion Module interface

Power and Communication Interfaces

[Table 1](#) lists jumper information concerning the shunt status, functions, devices, and defaults affected of jumpers JP1, JP2, JP3, JP4, JP5, and JP6.

Table 1. Shunt Settings for the Z8 Encore! XP F1680 Development Board

Number	Shunts	Function	Pins Connected (IN/OUT)	Factory Settings
1	J1	AN3_IN	1–2 AN3_IN connected to AN3 on the JP3	2–3
			2–3 AN3_IN connected to Vout of DAC	Default
2	J2	RS-232	IN—RS-232 disabled	Default
			OUT—RS-232 enabled	OUT
4	J4	AVCC for MCU_S	IN—AVCC is connected to VCC_3.3 V	IN
			OUT—AVCC not connected	
5	J5	GND Test Point	N/A	
6	J6	VCC_3.3 V Test Point	N/A	

External Interface Headers JP1 and JP2

External interface headers JP1 and JP2 are displayed in the schematic in [Figure 5](#) on page 11.

Kit Contents

For kit contents, refer to *Z8 Encore! XP[®] Dual F1680 Series Development Kit Quick Start Guide (QS0038)*.

Installation

Follow the directions in the *Z8 Encore! XP[®] Dual F1680 Series Development Kit Quick Start Guide (QS0038)* for software installation and setup of the Z8 Encore! XP Dual F1680 Series Development Kit.

Schematics

This section includes schematics for the Z8 Encore! XP Dual F1680 Series Development Board. The following components appear in the schematic but are not installed on the board:

- C20
- J3
- R13 through R15
- U11

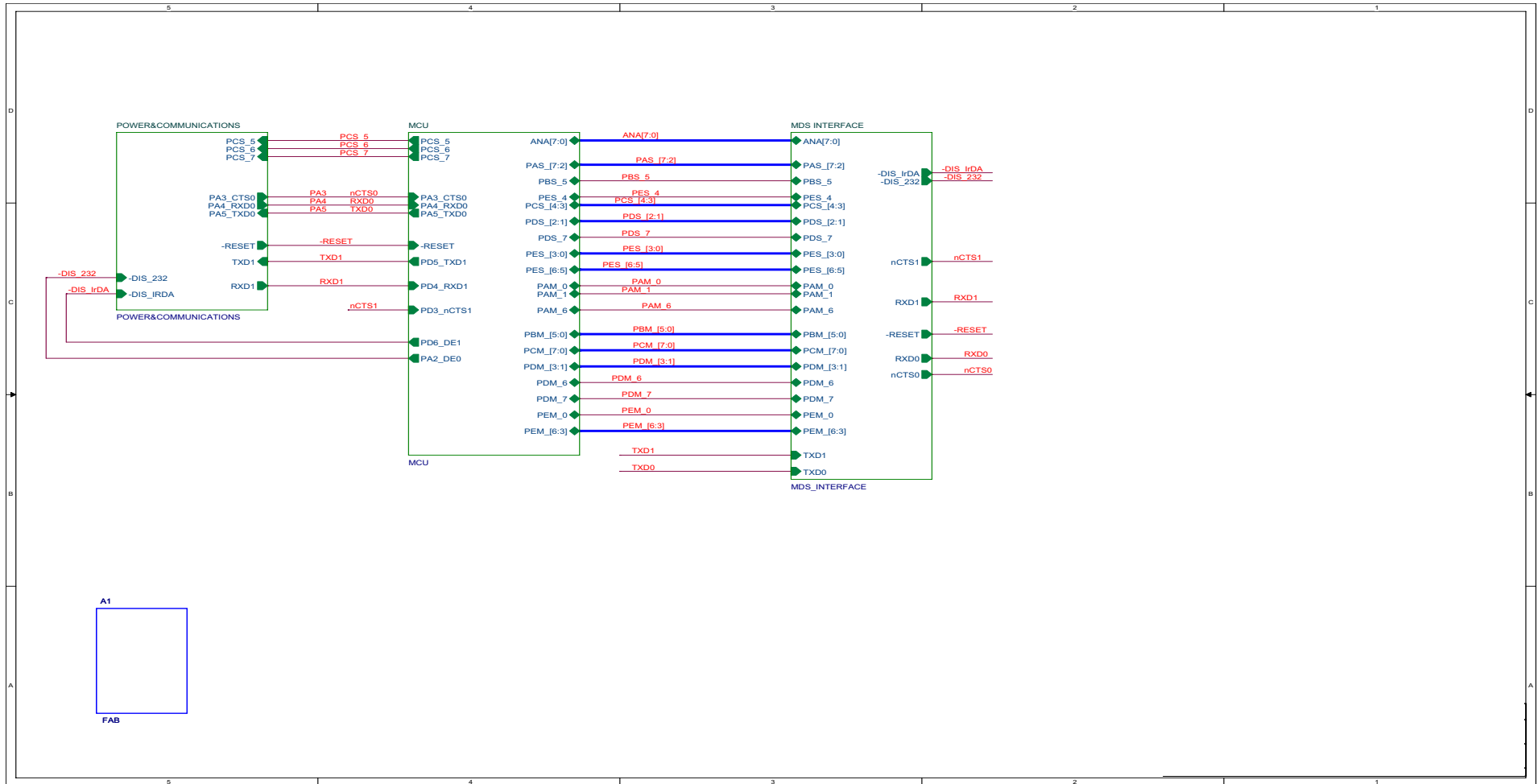

Figure 4. Z8 Encore! XP Dual F1680 Series MCU Development Board

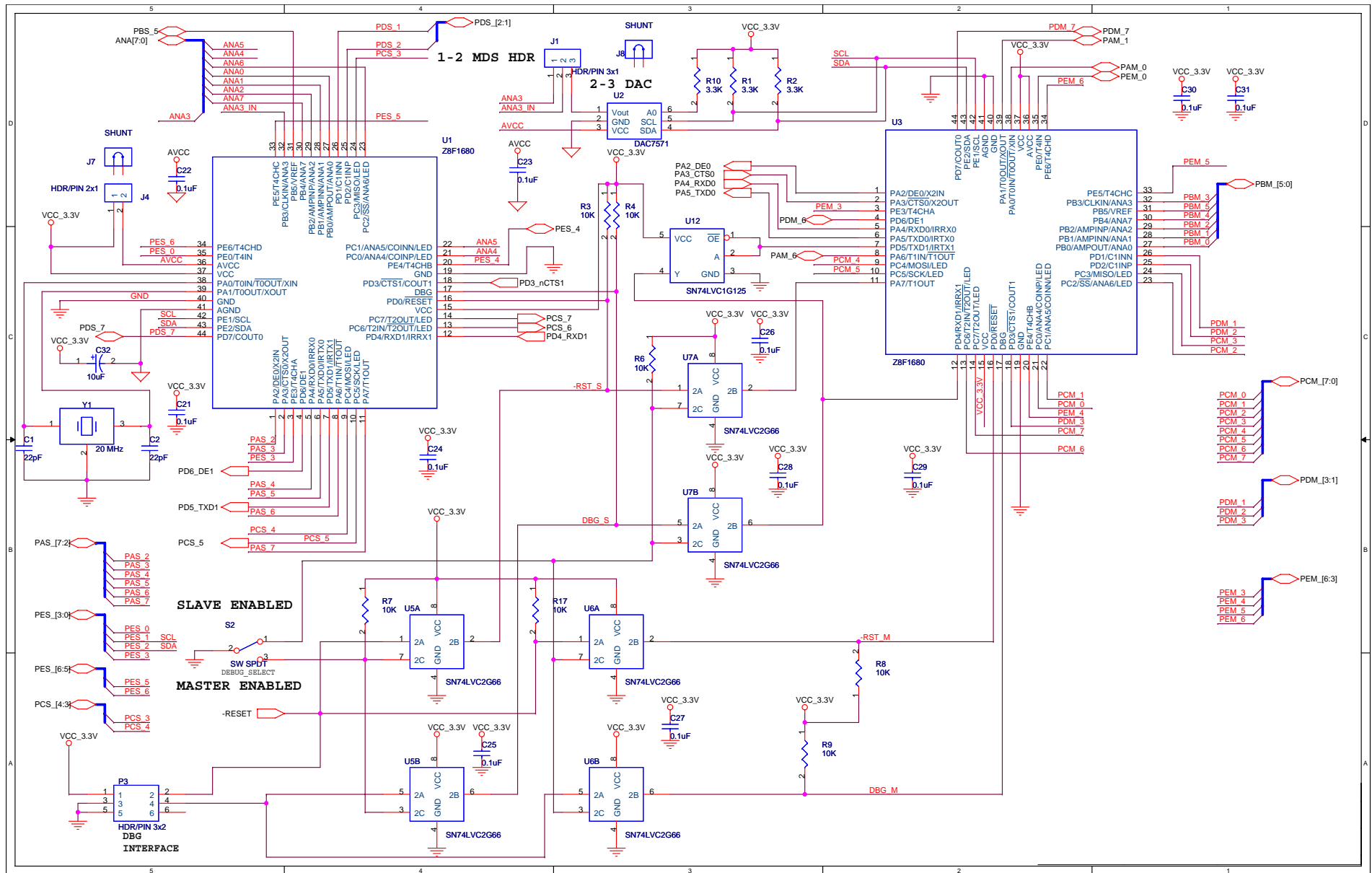

Figure 5. Z8 Encore! XP Dual F1680 Series MCU Development Board (Continued)

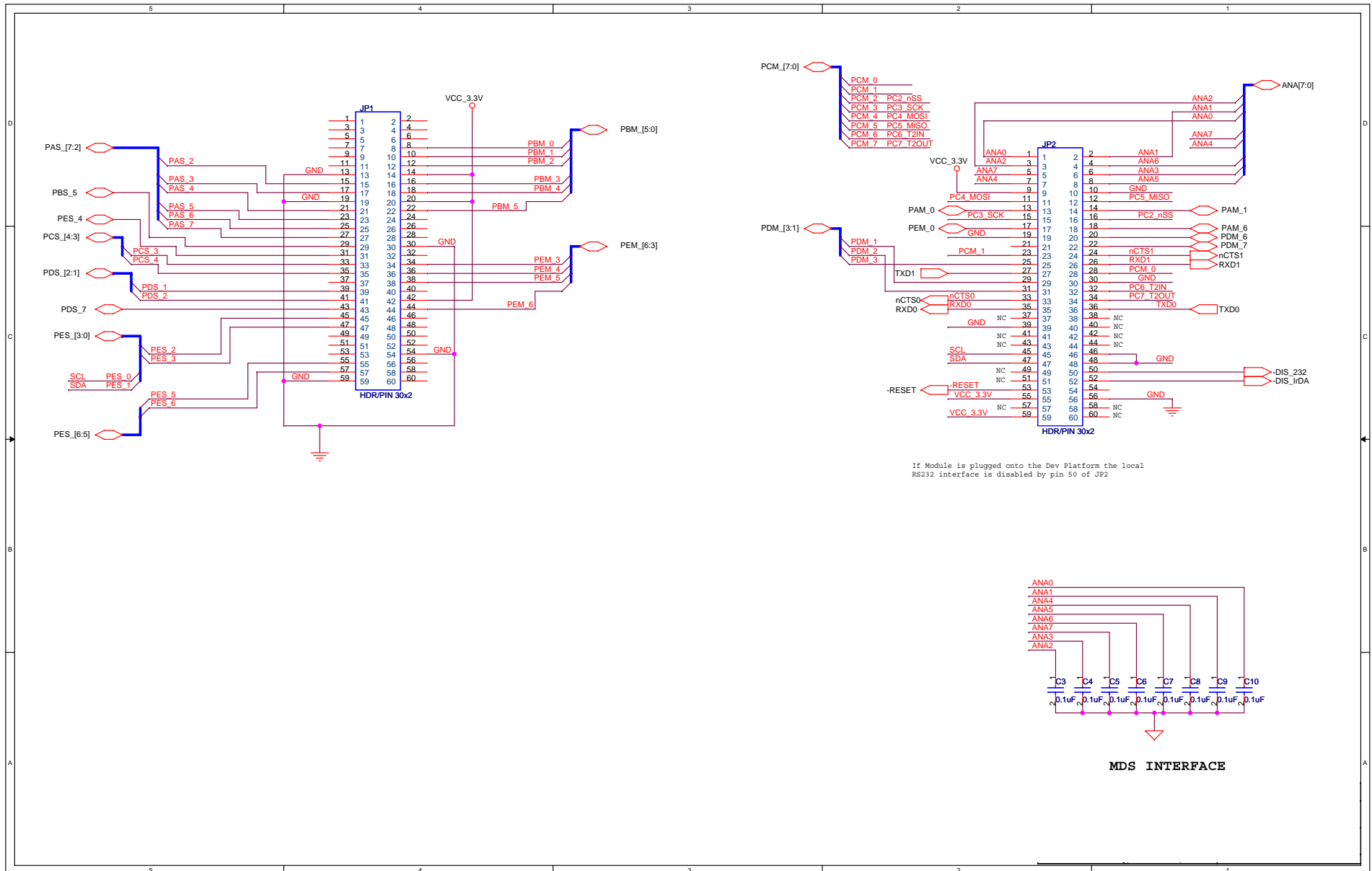

Figure 6. Z8 Encore! XP Dual F1680 Series MCU Development Board (Continued)

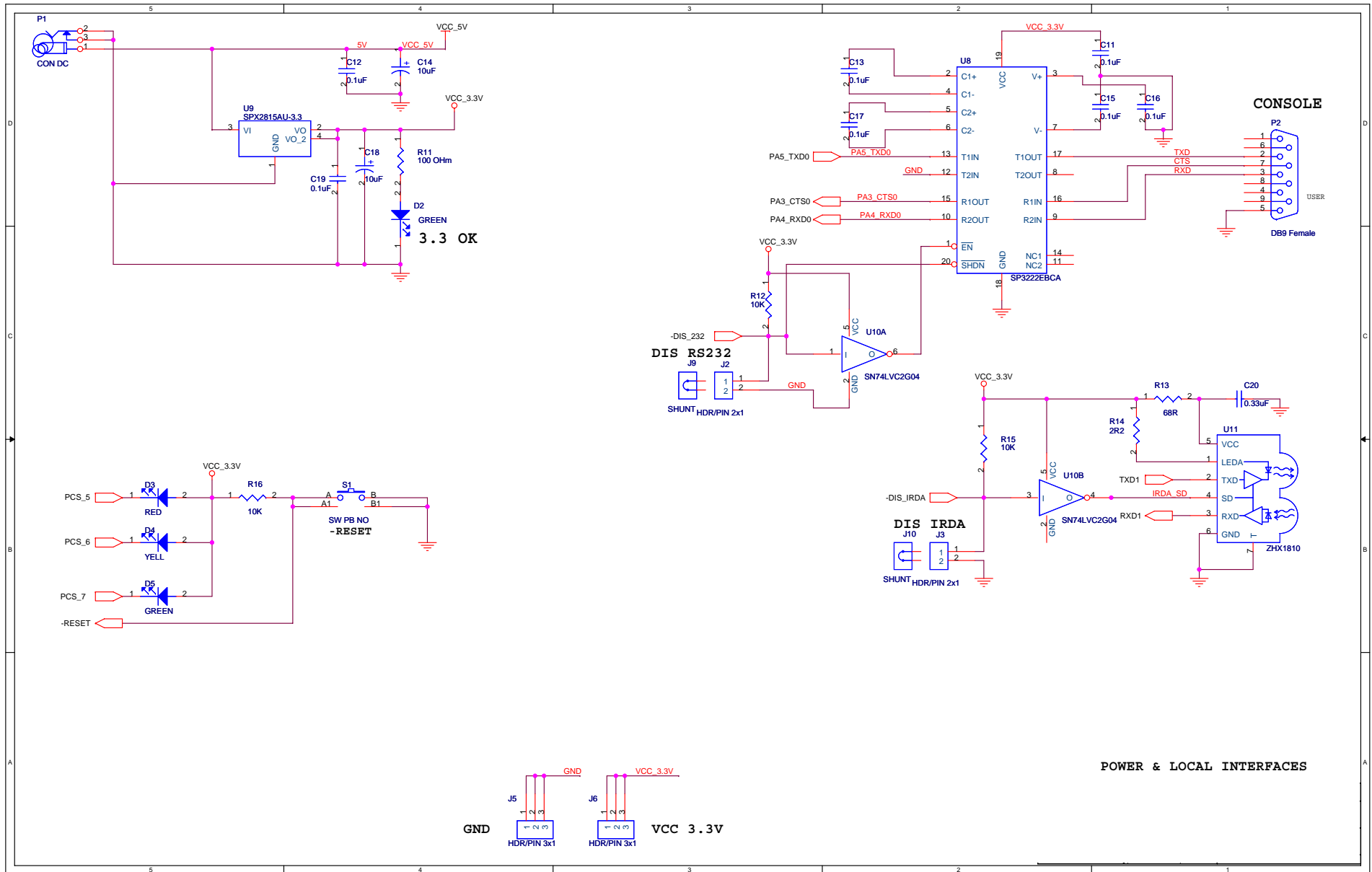

Figure 7. Z8 Encore! XP Dual F1680 Series MCU Development Board (Continued)



Customer Support

For answers to technical questions about the product, documentation, or any other issues with Zilog's offerings, please visit Zilog's Knowledge Base at <http://www.zilog.com/kb>.

For any comments, detail technical questions, or reporting problems, please visit Zilog's Technical Support at <http://support.zilog.com>.



Warning: DO NOT USE IN LIFE SUPPORT

LIFE SUPPORT POLICY

ZILOG'S PRODUCTS ARE NOT AUTHORIZED FOR USE AS CRITICAL COMPONENTS IN LIFE SUPPORT DEVICES OR SYSTEMS WITHOUT THE EXPRESS PRIOR WRITTEN APPROVAL OF THE PRESIDENT AND GENERAL COUNSEL OF ZILOG CORPORATION.

As used herein

Life support devices or systems are devices which (a) are intended for surgical implant into the body, or (b) support or sustain life and whose failure to perform when properly used in accordance with instructions for use provided in the labeling can be reasonably expected to result in a significant injury to the user. A critical component is any component in a life support device or system whose failure to perform can be reasonably expected to cause the failure of the life support device or system or to affect its safety or effectiveness.

Document Disclaimer

©2008 by Zilog, Inc. All rights reserved. Information in this publication concerning the devices, applications, or technology described is intended to suggest possible uses and may be superseded. ZILOG, INC. DOES NOT ASSUME LIABILITY FOR OR PROVIDE A REPRESENTATION OF ACCURACY OF THE INFORMATION, DEVICES, OR TECHNOLOGY DESCRIBED IN THIS DOCUMENT. ZILOG ALSO DOES NOT ASSUME LIABILITY FOR INTELLECTUAL PROPERTY INFRINGEMENT RELATED IN ANY MANNER TO USE OF INFORMATION, DEVICES, OR TECHNOLOGY DESCRIBED HEREIN OR OTHERWISE. The information contained within this document has been verified according to the general principles of electrical and mechanical engineering.

Z8 Encore! XP is a registered trademark of Zilog, Inc. All other product or service names are the property of their respective owners.

Mouser Electronics

Related Product Links

[692-Z8F16800144ZCOG - ZiLOG Z8F16800144ZCOG](#)