

DATA SHEET

mifare[®] & I•CODE

CL RD701

PEGODA Contactless Smart Card
Reader

Product Specification

November 2004

Revision 3.1

PUBLIC

MIFARE[®] & I²C Code Pegoda Contactless Card Reader**CL RD701****CONTENTS**

1	GENERAL INFORMATION	3
1.1	Scope.....	3
1.2	General Description.....	3
1.3	Features.....	4
1.4	Ordering Information.....	4
2	FUNCTIONAL UNITS	5
2.1	CL RD701 Pegoda Reader Parts.....	5
2.2	USB Type B Plug.....	6
2.3	Power Supply.....	7
3	ELECTRICAL CHARACTERISTICS	8
3.1	Operating Condition Range.....	8
3.2	Current Consumption.....	8
3.3	Operating distance.....	8
3.4	Interface Characteristics.....	8
3.4.1	<i>USB-Characteristics</i>	8
4	ELECTROMAGNETIC COMPATIBILITY	9
4.1	FCC Compliance Statement.....	9
4.2	COMPLIANCE INFORMATION according to 47CFR 2.1077.....	10
4.3	CE Declaration of Conformity.....	11
4.4	Mechanical Specification.....	12
4.4.1	<i>Side View</i>	12
4.4.2	<i>Bottom View</i>	13
5	REVISION HISTORY	14
	Contact Information	16

MIFARE[®] & I²C Code Pegoda Contactless Card Reader**CL RD701**

1 GENERAL INFORMATION**1.1 Scope**

This document describes the basic functionality and the electrical specifications of the CL RD701 'Pegoda' reader.

This contactless reader is designed for an easy reader adaptation to a PC to use this device for test and application purposes. Furthermore this reader can be taken as a reference design for new reader development based on the CL RC632 reader IC.

1.2 General Description

The Pegoda reader, CL RD701, is a contactless reader based on the CL RC632 reader IC. The CL RC632 is member of a family for highly integrated reader ICs for contactless communication at 13.56 MHz.

All layers of ISO14443A+B, ISO 15693 as well as the MIFARE[®] classic crypto are supported.

The Pegoda reader is designed to fulfil several requirements.

It covers all functionality of the CL RC632 to be able to use this reader as a reference design for a new hardware design based on the CL RC632 reader IC and is designed for easy PC adaptation and application development as well.

MIFARE[®] & I^oCode Pegoda Contactless Card Reader**CL RD701****1.3 Features**

- contactless smart card reader
- based on the CL RM701 reader module containing the CL RC632 reader IC
- contactless operating frequency 13.56 MHz
- Supports MIFARE[®] Dual Interface Card ICs and ISO 14443A part 1- 4
- Supports ISO 14443B
- Supports MIFARE[®] Classic crypto
- Supports ISO 15693
- Supports Philips ICODE[®]
- Supports higher data rates of up to 424 kbit/s
- Typical operating distance: 75 - 100mm
- CE and FCC compliant
- USB host interface
- USB bus powered 5 VDC power supply
- Unique serial number of each reader device
- Supported by Windows 98 OSR2, Windows ME, Windows 2000 and Windows XP.

1.4 Ordering Information

CL RD701/HAB can be ordered in bulk kits of 10 pieces. This means you cannot order e.g. 1 piece or 25 pieces but only a multiply of 10.

Type	12NC	Description
CL RD701 / HAB	9352 764 08122	Package containing: 1 pcs CL RD701 Pegoda reader, 1 pcs USB cable 1 pcs Ferrite

Table 1-1: CL RD701 Pegoda Reader Ordering Information

MIFARE[®] & I[•]Code Pegoda Contactless Card Reader**CL RD701**

2 FUNCTIONAL UNITS**2.1 CL RD701 Pegoda Reader Parts**

The Pegoda reader, CL RD701, is divided into two parts:

- CL RM701: reader module. This reader module is the basic print including the CL RC632, a μ -Controller and all interfaces to a host. Please refer to the data sheet '*CL RM701 Contactless reader module*'.
For description of CL RC632 please refer to data sheet '*Mifare & I[•]Code CL RC632 Multiple protocol contactless reader IC*'.
- MF AN700: a flexible Pegoda antenna. Please refer to the application note '*MIFARE[®] MF RM 700 Antenna and matching adapter description*'.

Note:

Additional documents can be received from Philips Semiconductors Internet Page:
<http://www.semiconductors.philips.com/markets/identification/datasheets/index.html#mifare>

MIFARE[®] & I²Code Pegoda Contactless Card Reader

CL RD701

2.2 USB Type B Plug

The USB type B plug is the default configuration of the Pegoda reader to connect the reader to a host PC.

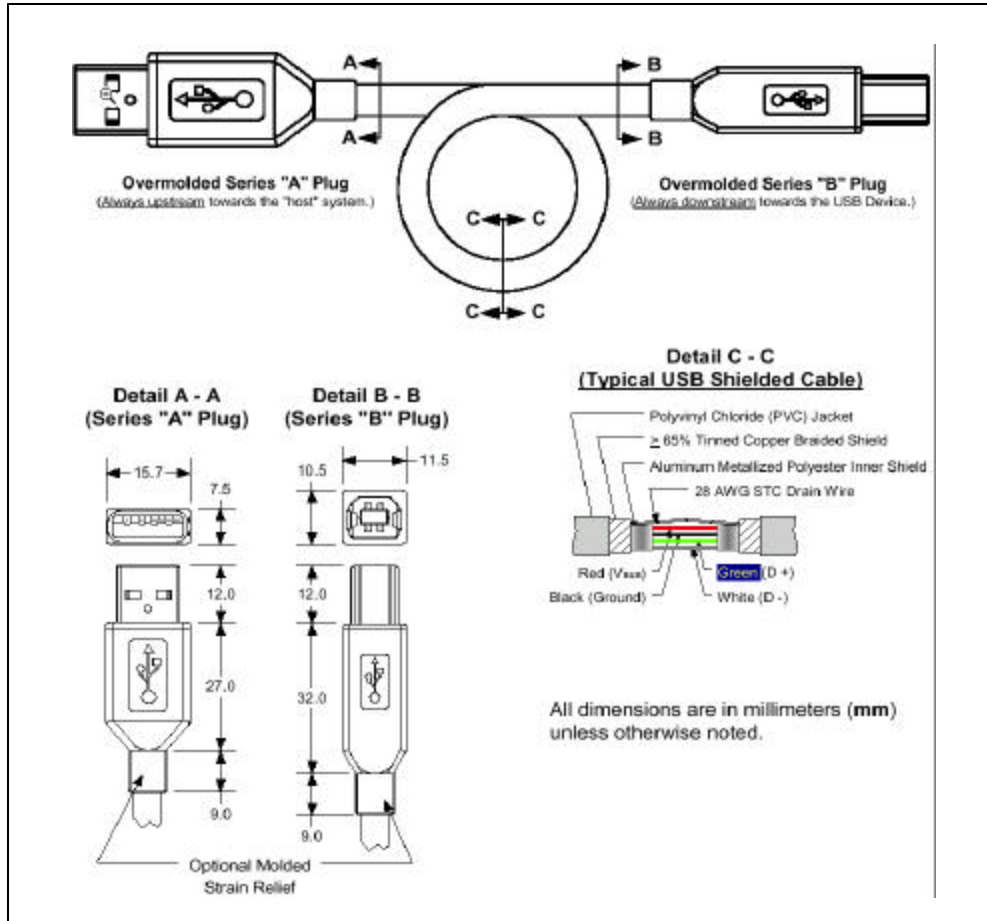

Figure 1. USB Type B connectors

The default configuration uses the USB cable to communicate to the Pegoda as well as to supply the 5 V supply voltage.

MIFARE[®] & I²C Code Pegoda Contactless Card Reader**CL RD701**

2.3 Power Supply

The CL RD701 is a bus powered 5 V USB device. No external power supply has to be connected to start to work with the Pegoda.

Note:

In order to fulfil the USB specification version 1.1, the reader module behaves after power on like a low power device. Having sent an activate command, the Pegoda is activated and the reader module switches to an idle state resulting in an increased power consumption.

MIFARE[®] & I²C Code Pegoda Contactless Card Reader**CL RD701****3 ELECTRICAL CHARACTERISTICS****3.1 Operating Condition Range**

SYMBOL	PARAMETER	CONDITIONS	MIN	TYP	MAX	UNIT
T _{amb}	Ambient Temperature	-	-10	+25	+70	°C
VDD	DC Supply Voltage	DVSS = 0V	4.5	5.0	5.5	V

*Table 3-1: Operating Condition Range***3.2 Current Consumption**

SYMBOL	PARAMETER	CONDITIONS	MIN	TYP	MAX	UNIT
I _{DVDD}	Supply Current	StandBy	-	70	-	mA
I _{DVDD}	Supply Current	Idle, RF off	-	160	-	mA
I _{DVDD}	Supply Current	Idle, RF on	-	250	-	mA

*Table 3-2: Current Consumption***3.3 Operating distance**

SYMBOL	PARAMETER	CONDITIONS	MIN	TYP	MAX	UNIT
OD	operating distance	measured from the middle of the reader surface	-	75	-	mm

*Table 3-3. Operating Distance***3.4 Interface Characteristics****3.4.1 USB-CHARACTERISTICS**

SYMBOL	PARAMETER	CONDITIONS	MIN	TYP	MAX	UNIT
USB-baud	USB- baudrate	cable length max. 3 m	-	12	-	Mbaud

Table 3-4USB Characteristics

Note: The FCC and CE certification are only valid when the USB cable is equipped with the shielding components.

MIFARE[®] & I[®]Code Pegoda Contactless Card Reader**CL RD701**

4 ELECTROMAGNETIC COMPATIBILITY

The CL RD701 fulfils the following requirements of electromagnetic compatibility:

FCC, Part 15 and CE.

4.1 FCC Compliance Statement

NOTE: This equipment has been tested and found to comply with the limits for a Class B digital device, pursuant to Part 15 of the FCC Rules. These limits are designed to provide reasonable protection against harmful interference when the equipment is operated in a residential environment. This equipment generates, uses, and can radiate radio frequency energy and, if not installed and used in accordance with the instruction manual, may cause harmful interference to radio communications. However, there is no guarantee that interference will not occur in a particular installation. If this equipment does cause harmful interference to radio or television reception, which can be determined by turning the equipment off and on, the user is encouraged to try to correct the interference by one or more of the following measures:

Reorient or relocate the receiving antenna.

Increase the separation between the equipment and receiver.

Connect the equipment into an outlet on a circuit different from that to which the receiver is connected.

Consult the dealer or an experienced radio/TV technician for help.

Caution!

The Federal Communications Commission warns the users that changes or modifications to the unit not expressly approved by the party responsible for compliance could void the user's authority to operate the equipment.

Accessories: This equipment has been tested and found to comply with the limits of a Class A digital device. The accessories associated with this equipment are as follows:

- Shielded video cable

These accessories are required to be used in order to ensure compliance with FCC rules.

MIFARE[®] & I[®]Code Pegoda Contactless Card Reader

CL RD701

4.2 COMPLIANCE INFORMATION according to 47CFR 2.1077

We,

Philips Semiconductors Gratkorn GmbH

811 Argues Avenue

Sunnyvale, CA94088 -3409, USA

Telephone 1800 234 7381

declare that the product

CL RD 701,

FCC ID OWR40089

is in conformity with Part 15 of the FCC Rules.

Operation of this product is subject to the following conditions: (1) this device may not cause harmful interference, and (2) this device must accept any interference received, including interference that may cause undesired operation.

MIFARE[®] & I^oCode Pegoda Contactless Card Reader**CL RD701****4.3 CE Declaration of Conformity**

This Information Technology Equipment has been tested and found to comply with the following European directives:

Harmonised Standards applied	Description
EN 300 330: (2001-06)	Air interface of the radio systems pursuant to § 3(2) (Article 3(2))
EN 60950:1992	Health and safety requirements pursuant to § 3 (1) 1. (Article 3(1) a)
EN 301 489-9 :(2000-09)	Protection requirements concerning electromagnetic compatibility § 3(1)2,(Article 3(1)(b))

Manufacturer's Name: Philips Semiconductors Gratkorn GmbH

Manufacturer's Address: Mikronweg 1, A-8101 Gratkorn, Austria

Type of Equipment: Contactless Smart Card Reader

Model No.: CL RD701

Philips Semiconductors hereby declare that the equipment specified above conforms to the above Directive(s) and Standard(s), and said equipment is in conformity with the relevant harmonised standards as mentioned above.

MIFARE[®] & I[®]Code Pegoda Contactless Card Reader

CL RD701

4.4 Mechanical Specification

4.4.1 SIDE VIEW

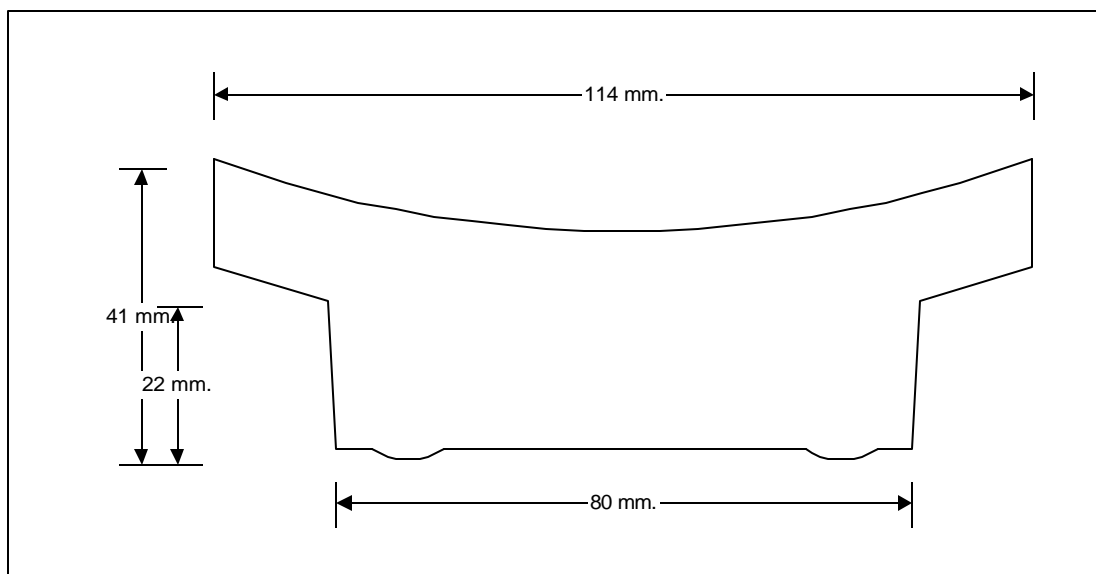

Figure 2. Side View

MIFARE[®] & I[®]Code Pegoda Contactless Card Reader

CL RD701

4.4.2 BOTTOM VIEW

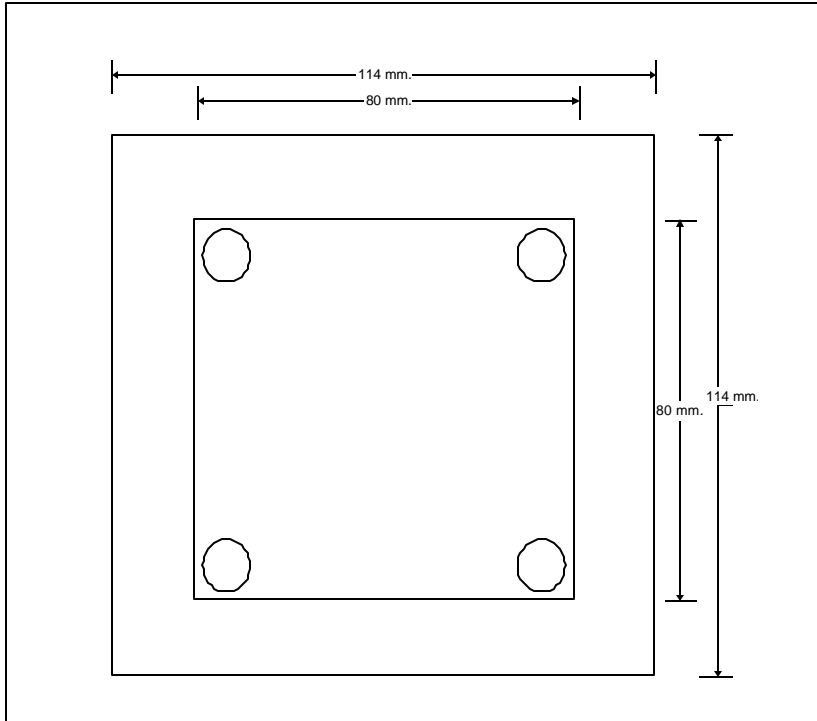

Figure 3. Bottom View

MIFARE[®] & I[®]Code Pegoda Contactless Card Reader**CL RD701****5 REVISION HISTORY**

REVISION	DATE	CPCN	PAGE	DESCRIPTION
3.1	Nov 2004	200411026	4	Changed ordering type information for CL RD701 / HAB
3.0	July 2004	-	-	Product Version
2.0	April 2004	-	-	first published version

Table 5-1: Document Revision History

Definitions

Data sheet status	
Objective specification	This data sheet contains target or goal specifications for product development.
Preliminary specification	This data sheet contains preliminary data; supplementary data may be published later.
Product specification	This data sheet contains final product specifications.
Limiting values	
Limiting values given are in accordance with the Absolute Maximum Rating System (IEC 134). Stress above one or more of the limiting values may cause permanent damage to the device. These are stress ratings only and operation of the device at these or at any other conditions above those given in the Characteristics section of the specification is not implied. Exposure to limiting values for extended periods may affect device reliability.	
Application information	
Where application information is given, it is advisory and does not form part of the specification.	

Life support applications

These products are not designed for use in life support appliances, devices, or systems where malfunction of these products can reasonably be expected to result in personal injury. Philips customers using or selling these products for use in such applications do so on their own risk and agree to fully indemnify Philips for any damages resulting from such improper use or sale.

Philips Semiconductors - a worldwide company

Contact Information

For additional information please visit <http://www.semiconductors.philips.com>. Fax: **+31 40 27 24825**

For sales offices addresses send e-mail to: sales.addresses@www.semiconductors.philips.com.

© Koninklijke Philips Electronics N.V. 2002

SCA74

All rights are reserved. Reproduction in whole or in part is prohibited without the prior written consent of the copyright owner.

The information presented in this document does not form part of any quotation or contract, is believed to be accurate and reliable and may be changed without any notice. No liability will be accepted by the publisher for any consequence of its use. Publication thereof does not convey nor imply any license under patent- or other industrial or intellectual property rights.

**Philips
Semiconductors**

Let's make things better.



PHILIPS