

WIZ-SM10 Datasheet

(Version 0.1)

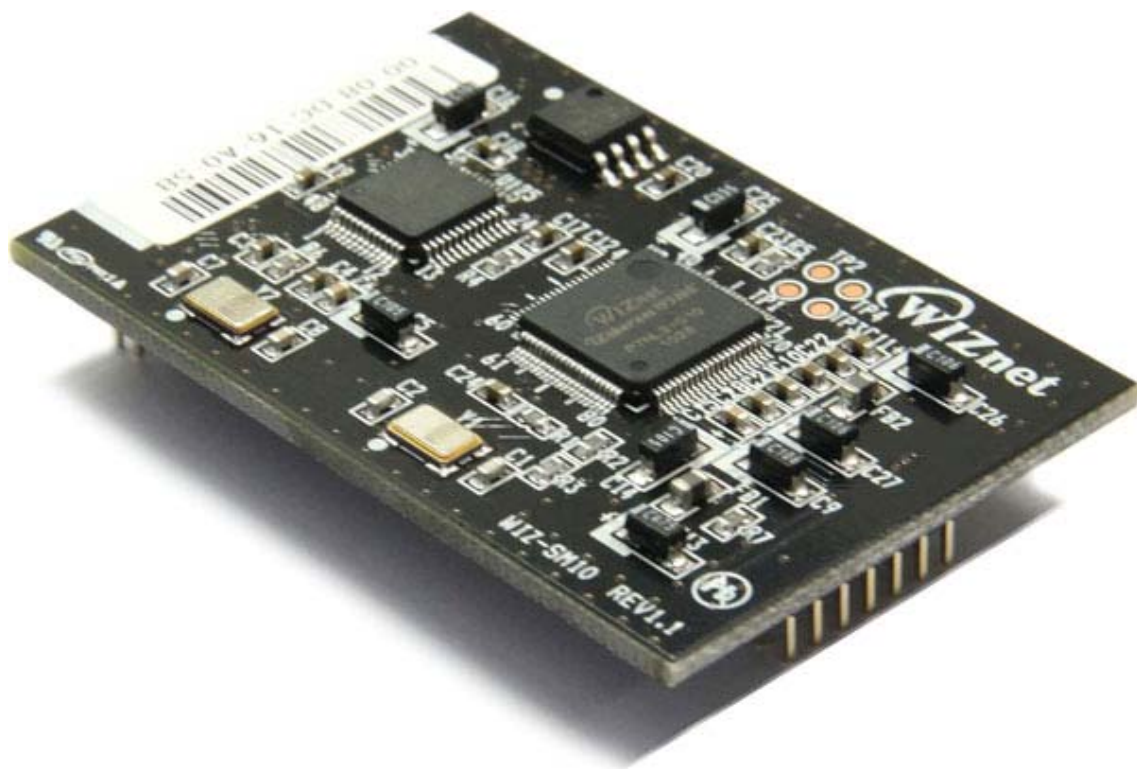

©2010 WIZnet Co., Ltd. All Rights Reserved.

☞ For more information, visit our website at <http://www.wiznet.co.kr>

Document Revision History

Date	Revision	Changes
2010-09-01	V0.1	Official Release

COPYRIGHT NOTICE

Copyright 2010 WIZnet Co., Ltd. All Rights Reserved.

Technical Support: support@wiznet.co.kr

Sales & Distribution: sales@wiznet.co.kr

For more information, visit our website at <http://www.wiznet.co.kr>

Contents

1. Introduction	1
1.1 Key features	1
1.2 Products specifications.....	2
1.3 WIZ-SM10 Block diagram.....	2
1.4 WIZ-SM10 Hardware Interface	3
2. Hardware Specifications	4
2.1 Dimension.....	4
3. WIZ-SM10 Base board.....	7
3.1 Hardware Interface of WIZ-SM10 Base board.....	7
4. Getting started	9
4.1 H/W connection	9
4.2 Configuration tool.....	10
5. WIZ-SM10 development enviroment	11
5.1 Source code.....	11
5.2 Firmware download.....	12

Figures

FIGURE 1. WIZ-SM10 HARDWARE INTERFACE.....	3
FIGURE 2. WIZ-SM10 DIMENSIONS (UNIT: MM)	4

Labels

TABLE 1. PRODUCTS SPECIFICATIONS	2
TABLE 2. PIN HEADER CONNECTOR PIN-ASSIGNMENT.....	6

1. Introduction

WIZ-SM10 module is designed for Serial to Ethernet application, especially the connection with smart metering devices using 2 UART and SPI interfaces, etc. RS-232, RS-485, M-bus, MicroSD memory, Wi-Fi and Zigbee modules, all of them can be connected with WIZ-SM10 via the UART and SPI interface.

In terms of accessories, the firmware code matched with WIZ-SM10 and configuration tool are available. Users can develop their own applications using these useful accessories.

1.1 Key Features

- 2 port Serial to Ethernet gateway
- Multiple serial commands for serial configuration
- Static IP, DHCP, PPPoE
- DNS
- Configuration tool program
- 10/100 Mbps Ethernet and 230Kbps serial communication
- mSD for data logging
- UART and SPI interface for connecting with external device

1.2 Products specifications

Architecture	TCP / IP	W5100
	PHY	Included in W5100 Auto negotiation (Full-duplex and Half-duplex) Auto MDI/MDIX
	Serial	2 Port RS-232C
	MCU	STM32F103C8T6 (STmicro CortexM3) LQFP 48 package Internal 64KBytes FLASH memory Internal 20KBytes embedded SRAM
Dimensions		55mm x 35mm x 10mm
Connector type		2.0 mm Pitch Pin-header, 14Pin & 28Pin
Input voltage		DC 3.3V
Power consumption		Under 150mA
Temperature		0°C ~ 70°C (Operation), -40°C ~ 85°C (Storage)
Humidity		10 ~ 90%

Table 1. Products specifications

1.3 WIZ-SM10 Block diagram

The picture below shows the WIZ-SM10 block diagram. STM32F103 and W5100 which are connected via SPI interface are adopted as MCU and Ethernet communication chip respectively. mSD or other SPI devices can be connected with STM32F103's second SPI interface. RS485 communication is also available using STM32F103's UART2.

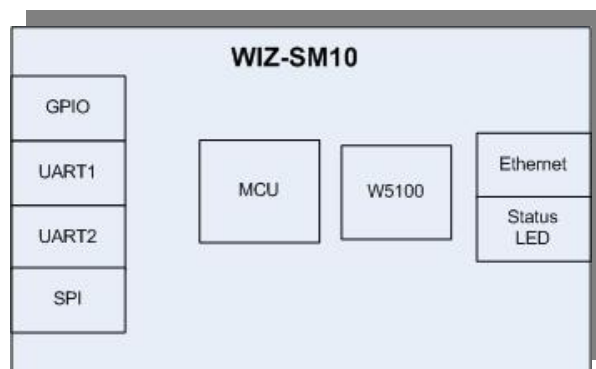

1.4 WIZ-SM10 Hardware Interface

The main elements of module are as follows:

Face side

- W5100

- STM32F103

- Serial flash (optional)

Reverse side

- Connector (2mm pitch)

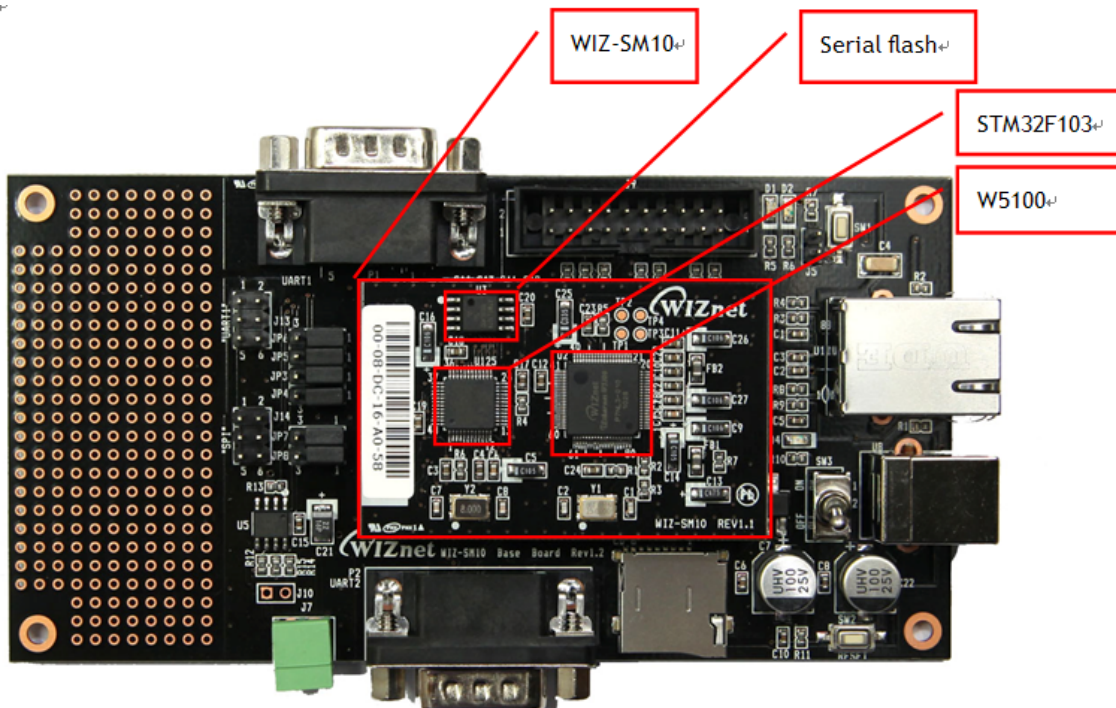

Figure 1. WIZ-SM10 Hardware Interface

2. Hardware Specifications

2.1 Dimension

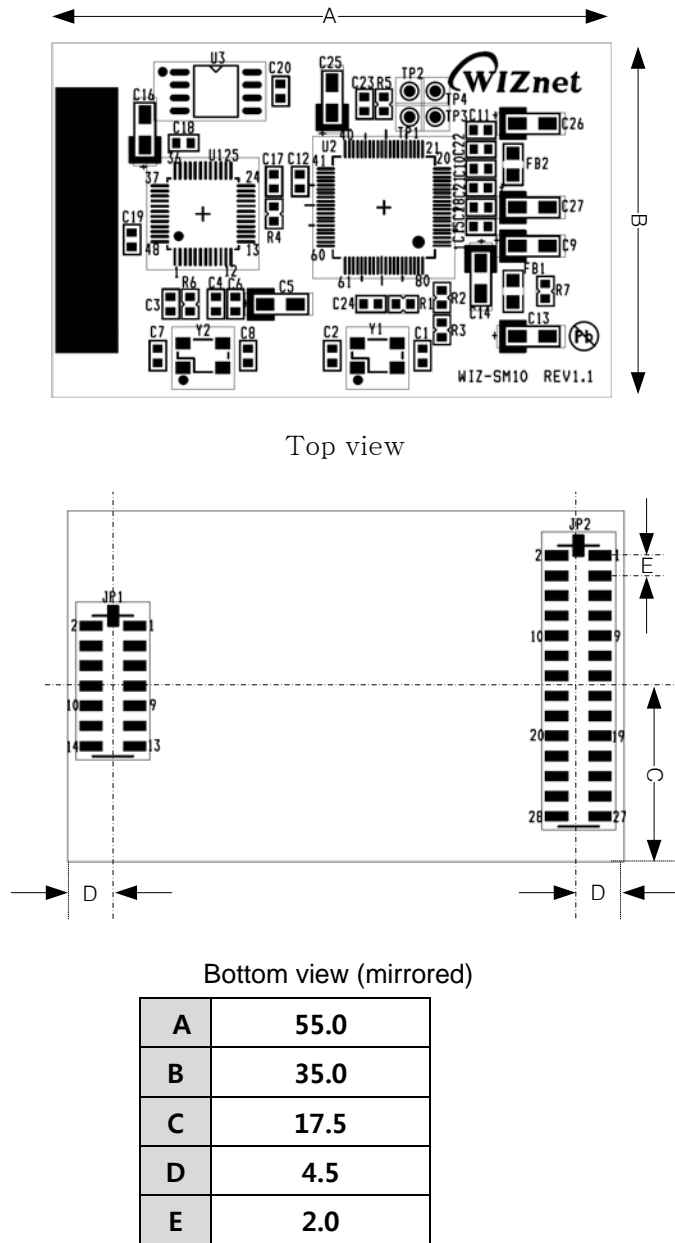
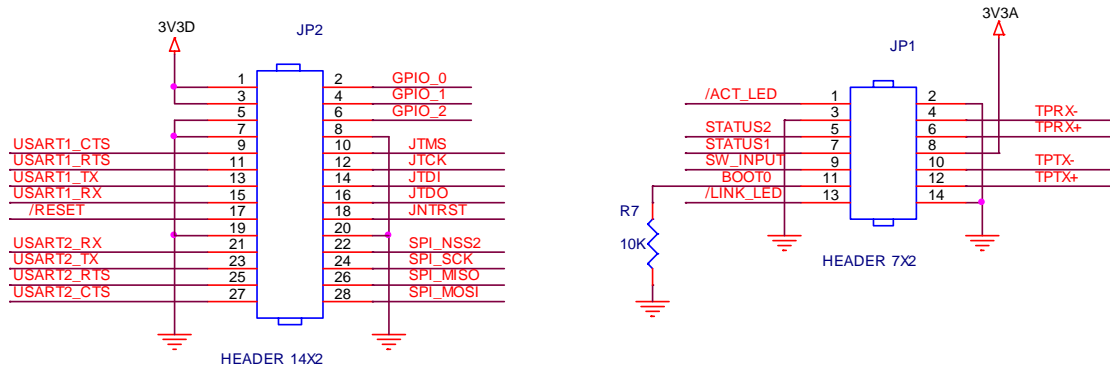

Figure 2. WIZ-SM10 Dimensions (unit: mm)

2.2 Connector Specification



JP1

Pin #	I/O	Signal	Description
1	O	/ACT_LED	Low active, Active LED
2	P	GND	System Ground
3	P	GND	System Ground
4	I	TPRX-	Ethernet signal
5	O	STATUS2	Low active, Indicate the connection status
6	I	TPRX+	Ethernet signal
7	O	STATUS1	Low active, Indicate the connection status
8	P	3V3A	3.3V Power, Should be connected to center tap of transformer
9	I	SW_INPUT	This pin is low-active. So, when it goes low and /RESET is active, serial bootloader will be enabled. For more details, refer to SM-10 development environment.
10	O	TPTX-	Ethernet signal
11	I	BOOT0	This pin is high-active. So, when it goes high and /RESET is active, the connection with ST flash loader will be enabled.
12	O	TPTX+	Ethernet signal
13	O	/LINK_LED	Low active, Link LED
14	P	GND	System Ground

JP2

Pin #	I/O	Signal	Description
1	P	3V3D	3.3V Power supply input
2		GPIO_0	Programmable GPIO signal
3	P	3V3D	3.3V Power supply input
4		GPIO_0	Programmable GPIO signal
5	P	GND	System Ground
6		GPIO_0	Programmable GPIO signal
7	P	GND	System Ground
8	P	GND	System Ground
9	I	UART1_CTS	UART1 CTS signal
10	I	JTMS	JTAG signal
11	O	UART1_RTS	UART1 RTS signal
12	I	JTCK	JTAG signal
13	O	UART1_TX	UART1 Tx signal
14	I	JTDI	JTAG signal
15	I	UART1_RX	UART1 Rx signal
16	O	JTDO	JTAG signal
17	I	/RESET	Low active reset input
18	I	JNTRST	JTAG signal
19	P	GND	System Ground
20	P	GND	System Ground
21	I	UART2_RX	UART2 Rx signal
22	O	SPI_NSS2	SPI chip select signal
23	O	UART2_TX	UART2 Tx signal
24	O	SPI_SCK	SPI clock signal
25	O	UART2_RTS	UART2 RTS signal
26	I	SPI_MISO	SPI MISO signal
27	I	UART2_CTS	UART2 CTS signal
28	O	SPI_MOSI	SPI MOSI signal

Table 2. Pin Header Connector PIN-Assignment

3. WIZ-SM10 Base board

WIZ-SM10 Base board is designed for evaluate WIZ-SM10's performance. The main elements of base board are as follows.

3.1 Hardware Interface of WIZ-SM10 Base board

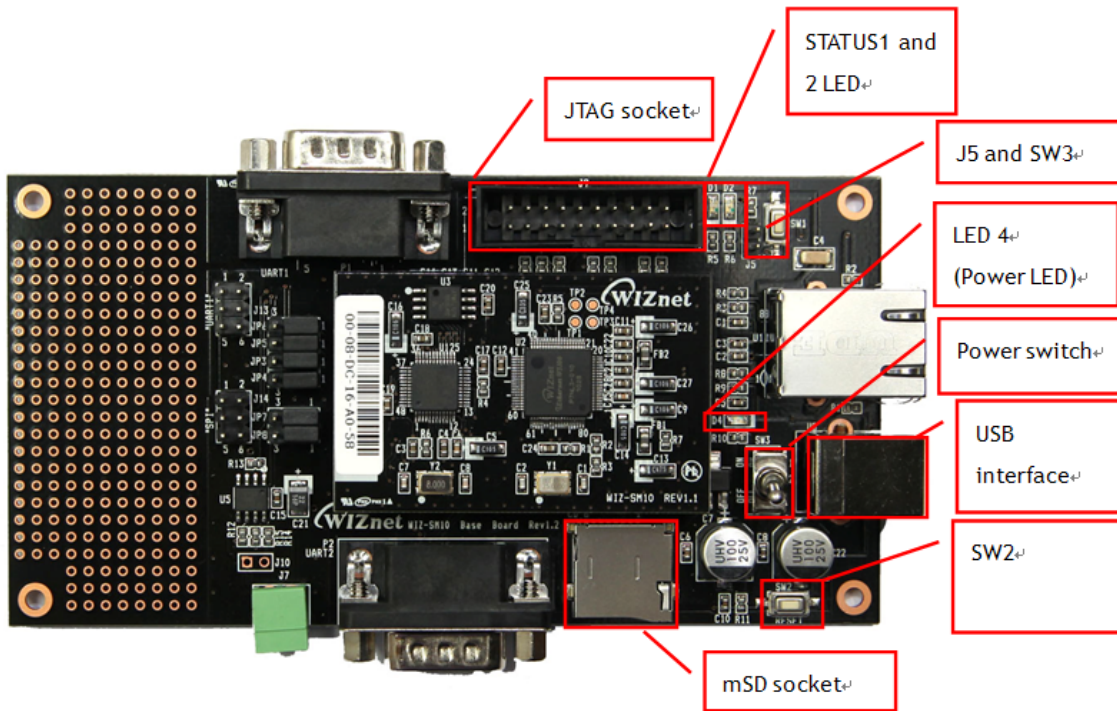

3.1.1 Power supply

5v and 3.3v power are available via USB interface and related regulator. If power is properly set, LED D4 will turn on. SW3 is Power switch. SW2 is reset switch which is low active.

3.1.2 mSD socket

mSD can be connected and controlled via MCU's SPI interface. After placing mSD memory properly in mSD socket, data reading and writing are available. This makes it feasible for users to store data as FAT32 file system for example.

3.1.3 JTAG socket

20-pin JTAG socket is available. Users may debug their development through this interface.

3.1.4 LED for status demonstration

When the connection that between STATUSn pin (STATUS1, STATUS2) and their corresponding LEDs are completed, F/W is able to control LED's on/off.

3.1.5 Programming interface (J5, SW1)

1) After shorting J5, BOOT0 signal will be activated. In this moment, if users press SW1 they are able to use software "STMicroelectronics flash loader" (Made in ST) to write MCU's flash (For WIZ-SM10, users usually use "STMicroelectronics flash loader" to upload UART_boot or Network_boot firmware file).

2) Pin SW1 is connected with SW_INPUT. When users press SW1, SW_INPUT pin goes low.

3) When J5 is in normal situation (non-short situation), turn on power and then uploaded UART bootloader will run. This bootloader firstly check whether SW_INPUT is low. If it is low, application firmware update menu is displayed and you can update the firmware using serial port. That is to say, if users want to see the application firmware update menu, they must keep press SW1 and then press SW2 to reset system.

3.1.6 SPI interface

J14 shows the circuit of SPI interface. GPIO0 pin is the CS pin which is low active.

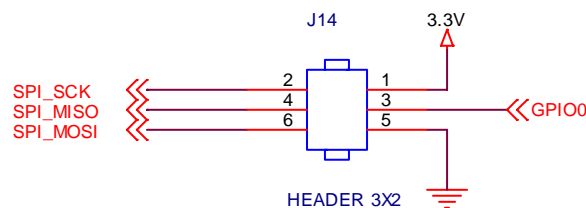

3.1.7 Serial interface

Through corresponding RS232 transceivers, UART1 and UART2 connect with P1 and P2 DB9 interface respectively. Besides basic TX and RX communication, RTS and CTS are also available as long as making the best of I/O. WIZ-SM10 base board provides UART1's signal interface, as shown in picture below. By that, UART1 can be used for other purpose, such as I/O.

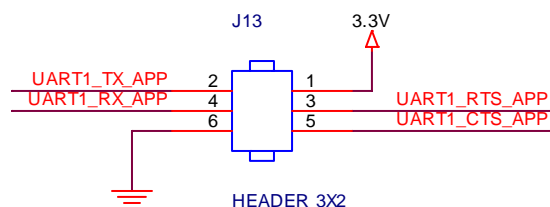

If users would like to use TTL level UART signal, please short the 2nd and 3rd pins in jumpers JP3, JP4, JP5 and JP6 respectively. For RS232 level UART signal, please short 1st and 2nd pins in jumpers JP3, JP4, JP5 and JP6 respectively.

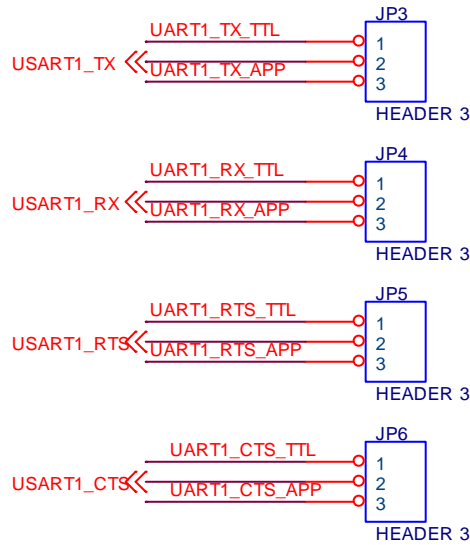

By configuring jumpers JP7 and JP8 properly, UART2 can also be used as RS232 and other purpose, such as RS485. If use RS485, please short 2,3 in JP7 and JP8. If use RS232, please short 1,2 in JP7 and JP8.

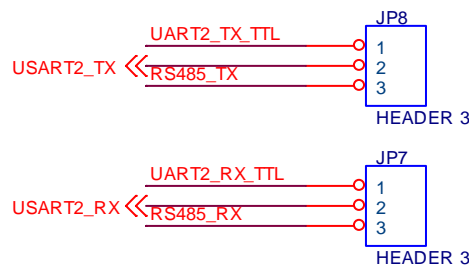

4. Get started

4.1 H/W connection

In order to implement WIZ-SM10 normally, some pins must be configured properly.

4.1.1 Power and GND

- . 3.3V power supply: JP2.1, JP2.3
- . GND: JP2.5, JP2.7, JP2.8, JP2.19, JP2.20, JP1.2, JP1.3, JP1.14

4.1.2 Reset

- . JP2.17: For normal initialization, external reset is necessary.

4.1.3 Transformer interface

JP1.4, JP1.6, JP1.10, JP1.12 and JP1.8 should be connected with transformer according to the picture below.

With respect to /ACT_LED and /LINK_LED signal, users may connect with 2 LED so as to

check the link or active status of transformer.

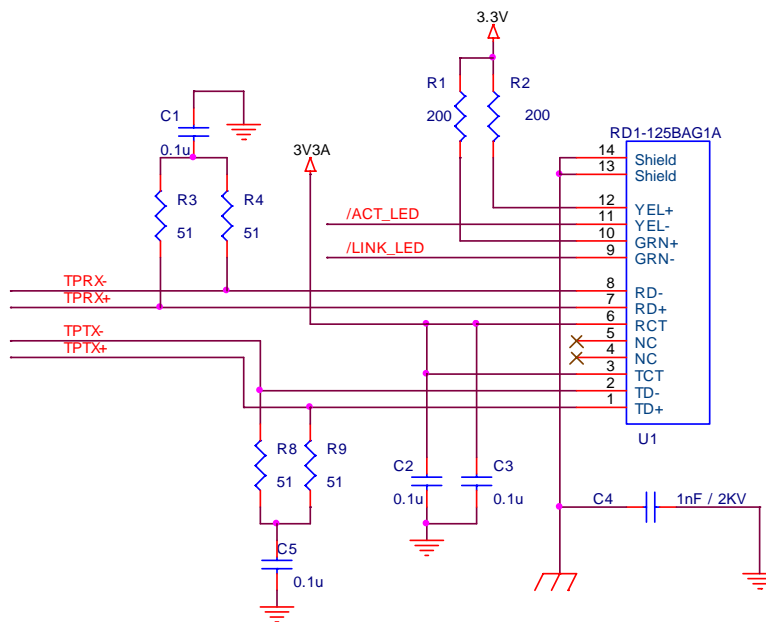

4.2 Configuration tool

When corresponding steps mentioned above and LAN cable connection are completed, users can search WIZ-SM10 using matched accessory-configuration tool. If the network parameters of WIZ-SM10 are in the same LAN with configuration tool, the MAC address of WIZ-SM10 will be listed in configuration tool.

In order to search WIZ-SM10, configuration tool uses UDP broadcast packet.

The picture below shows the normal screenshot of configuration tool after searching.

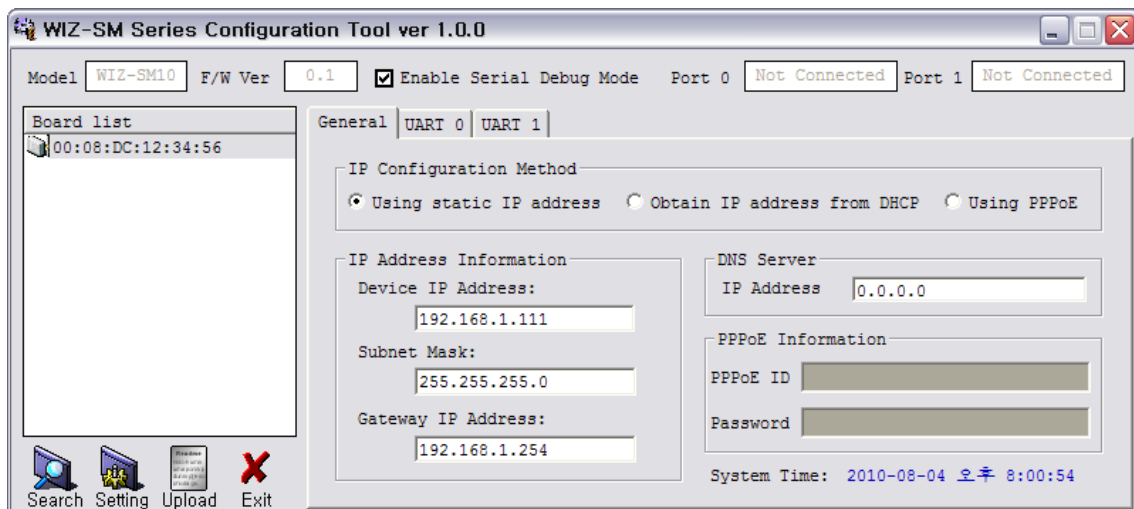

Of course, users can also change their configuration using this configuration tool.

5. WIZ-SM10 development environment

Users can modify source code according to their own development situations. With respect to compiler, we recommend users to use IAR Workbench for ARM.

5.1 Source code

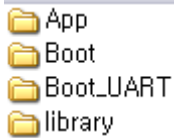

Source code for WIZ-SM10 is consisted of APP, library, Boot and Boot_UART, as shown in picture above.

Boot refers to network bootloader which enables application f/w update via Ethernet network. Boot_UART refers to UART bootloader which enables application f/w update via serial port.

Library refers to library functions provided by STmicro. Application-specific code is in APP folder.

WIZ_SM10_APP.eww is IAR Workbench-specific project file. After double clicking this file, users can overview and modify related source code in IAR Workbench.

Our provided application program starts to run from 0x4000, because network bootloader and UART bootloader are stored at 0x0000~0x3FFF.

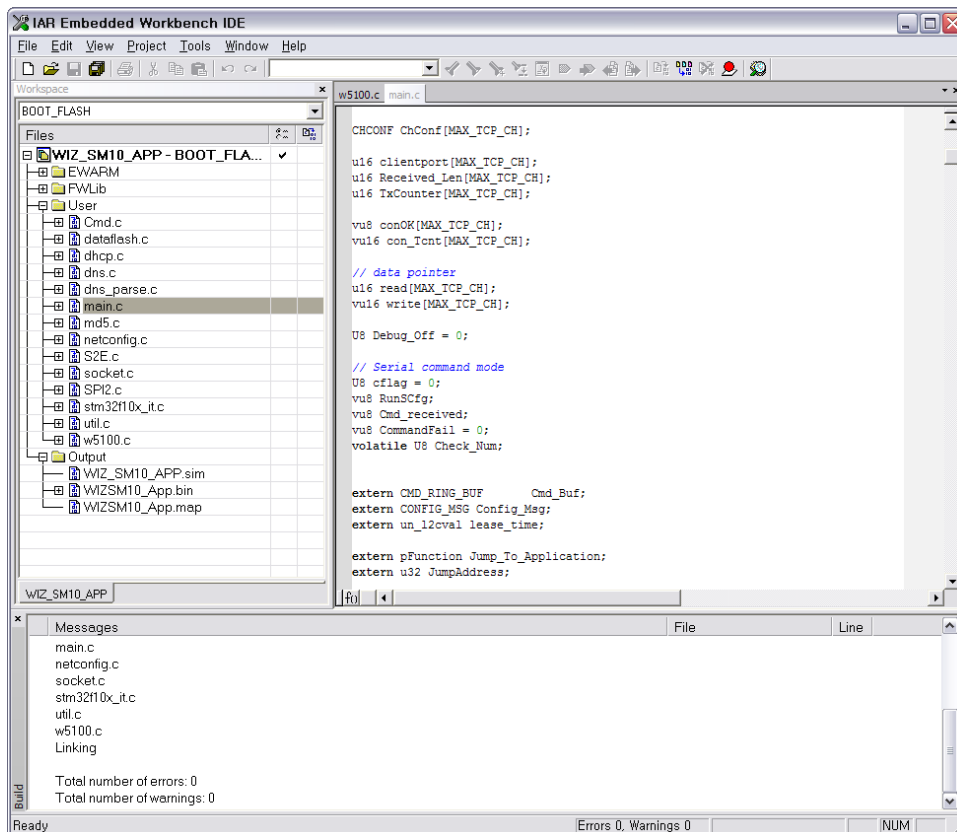

5.2 Firmware download

It is easy to use UART bootloader way to download firmware. The concrete steps are:

- 1) Turn off power in base board, and then short J5.
- 2) Turn on power in base board after connecting serial cable with PC COM port.
- 3) Run Flash loader program and configure COM port.

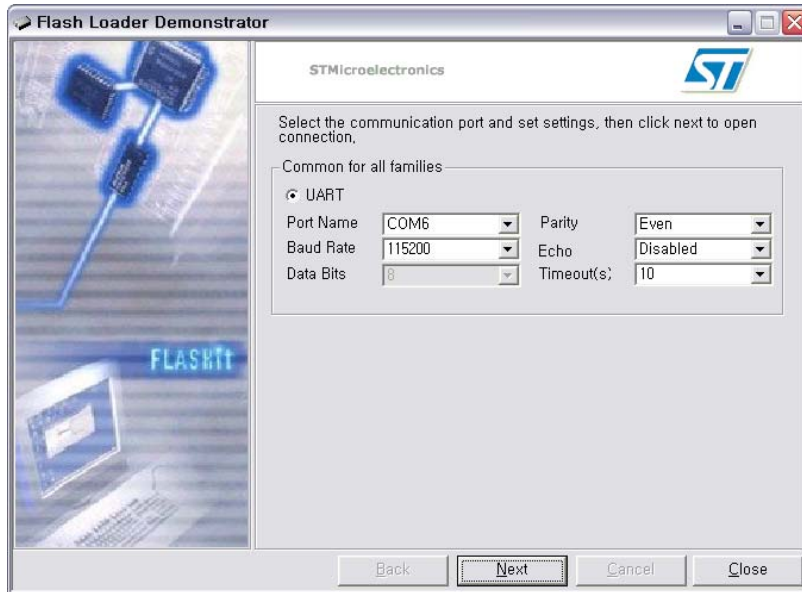

- 4) If COM port setting is OK, press next and then you will see the picture below.

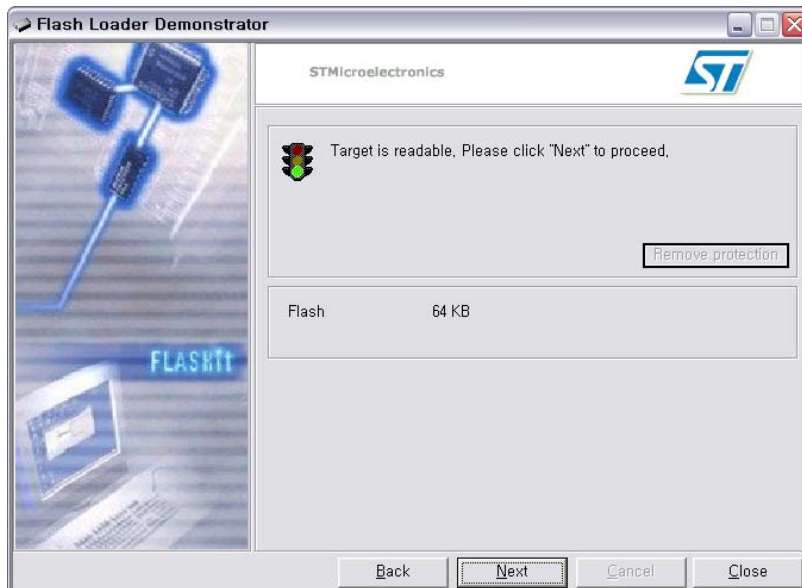

- 5) Press next and choose WIZ_SM_UART1_Boot.bin in this dialogue window.

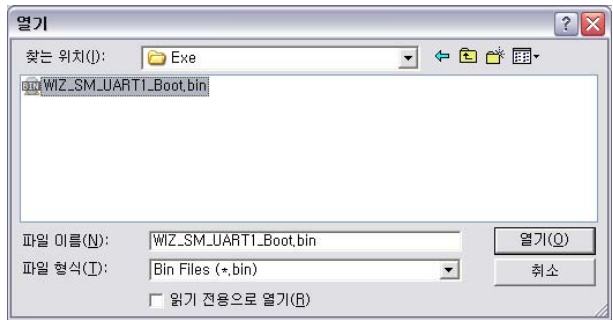

The directory of WIZ_SM_UART1_Boot.bin is:
 \\Boot_UART\\IAP\\project\\EWARM\\BOOT_FLASH\\Exe.

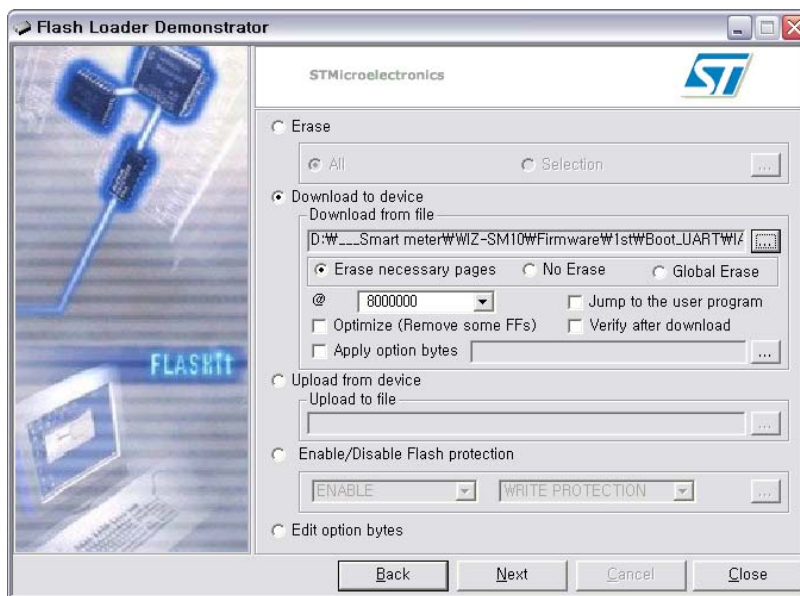

- 6) Press next and then Flash will be written.
 - 7) After 6), press close to end Flash loader program.
 - 8) Turn off power. Shift J5 to normal situation (non-short situation).
 - 9) Turn on power and then UART bootloader will run. This bootloader firstly check whether JP1 's 9th pin (SW_INPUT) is low or not. If it is low, firmware update menu is displayed and you can update the firmware using serial port.
- Next two pictures display the screenshot of serial configuration window and firmware update menu window respectively.

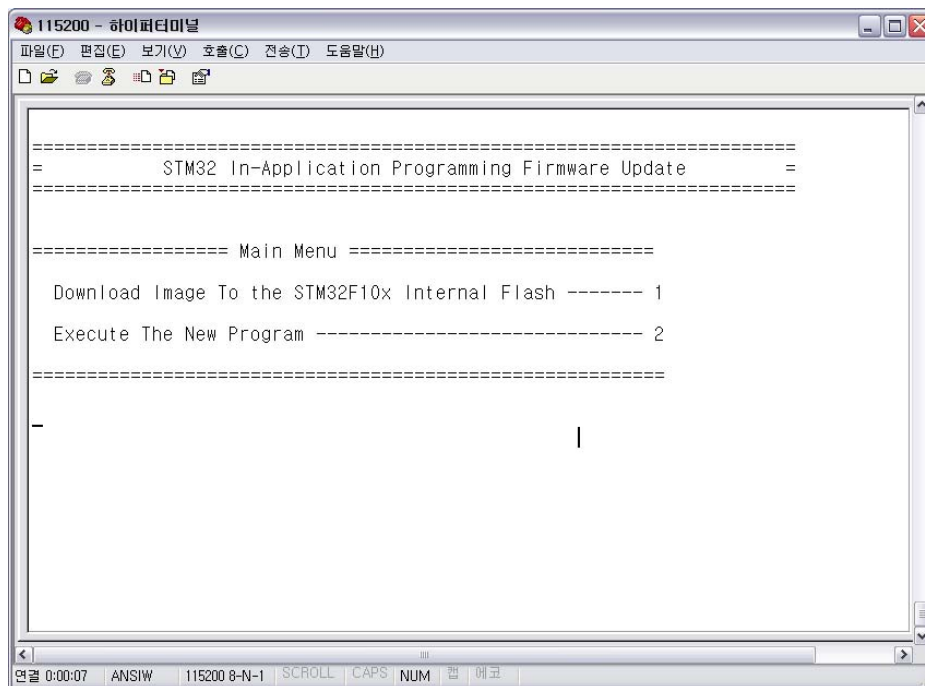
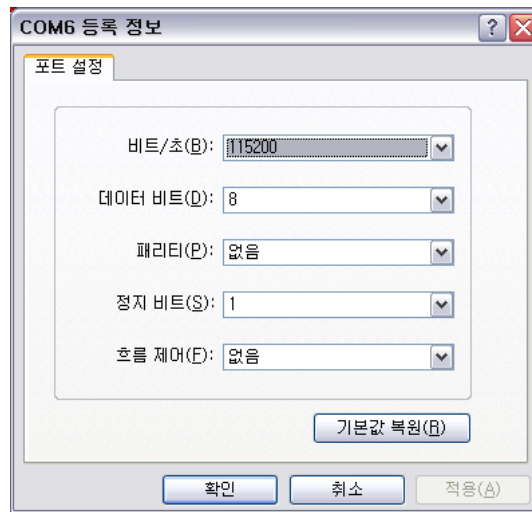

- 10) Type "1" in keyboard, string "Waiting for the file to send" will appear.
- 11) Select "Transmit(T)" in terminal menu toolbar, a new window will appear. In this window, users should select their application firmware file and **set the sending protocol as Ymodem**. Finally press "Send" button, the firmware will be sent to MCU.
- 12) Now type "2" in keyboard to run downloaded application firmware.

