



# DNT24C DNT24P

## Low Cost 2.4 GHz FHSS Transceiver Module with I/O

- 2.4 GHz Frequency Hopping Spread Spectrum Transceiver
- Point-to-point, Point-to-multipoint, Peer-to-peer and Store & Forward Capabilities
- Transmitter RF Power Configurable - 10 or 63 mW
- Transmitter EIRP 15.8 mW or 100 mW with 2 dBi Antenna
- 250 kbps RF Data Rate
- Serial Port Data Rate up to 250 kbps, SPI Port Data Rate up to 500 kbps
- 128-Bit AES Encryption
- Separate Serial Port for Diagnostics
- Analog and Digital I/O for Sensor Applications
- FCC and Canadian IC Certified for Unlicensed Operation

The DNT24 series FHSS transceiver modules provide a low-cost, versatile solution for wireless data communications in the 2.4 GHz ISM band. The DNT24 RF output power can be set at 10 or 63 mW. The DNT24 module includes analog, digital and serial I/O, providing the flexibility to serve applications ranging from cable replacements to sensor networks. The DNT24 transceiver module is easy to integrate and provides reliable wireless communications up to 5 miles in line-of-sight installations.



### DNT24 Absolute Maximum Ratings

Rating	Value	Units
Power Supply Input	-0.5 to +6.5	V
All Input/Output Pins	-0.5 to +3.3	V
Input Power to RFIO Port	0	dBm
Non-Operating Ambient Temperature Range	-40 to +85	°C

### DNT24 Electrical Characteristics

Characteristic	Sym	Notes	Minimum	Typical	Maximum	Units
Operating Frequency Range			2406		2475	MHz
Hop Duration		1	8		100	ms
Number of RF Channels		1	15 or 24			
Modulation			FSK			
RF Data Transmission Rate			250			kbps
Receiver Sensitivity @ 10 <sup>-5</sup> BER				-100		dBm
Transmitter RF Output Power		1	10 or 63 mW			mW
Optimum Antenna Impedance				50		Ω
RF Connection			U.FL Coaxial Connector			
System Topologies			Point-to-Point, Point-to-Multipoint, Peer-to-Peer and Store & Forward			
Access Scheme			Ad Hoc TDMA			

## DNT24 Electrical Characteristics

Characteristic	Sym	Notes	Minimum	Typical	Maximum	Units
ADC Input Range			0		2.7	V
ADC Input Resolution					12	bits
ADC Sample Rate				100		Hz
Signal Source Impedance for ADC Reading					10	K $\Omega$
ADC External Reference Voltage Range			1.0		2.7	V
DAC Output Range			0		3.3	V
DAC Output Resolution					12	bits
Primary and Diagnostic Serial Port Baud Rates			1.2, 2.4, 4.8, 9.6, 14.4, 19.2, 28.8, 38.4, 57.6, 115.2, 230.4, 250.0			kbps
Serial Peripheral Interface Data Rate			125		500	kbps
Digital I/O:						
Logic Low Input Level			-0.5		0.8	V
Logic High Input Level			2.45		3.3	V
Logic Input Internal Pull-up Resistor				20		K $\Omega$
Power Supply Voltage Range	V <sub>CC</sub>		+3.3		+5.5	Vdc
Power Supply Voltage Ripple					10	mV <sub>P-P</sub>
Peak Transmit Mode Current, 63 mW Output					140	mA
Average Operating Receive Current:						
Base and Remote Continuous Data Stream				55		mA
Remote, Linked, No Data Transmission				15		mA
Sleep Current		2		3	6	$\mu$ A
DNT24C Mounting			Reflow Soldering			
DNT24P Mounting			Socket			
Operating Temperature Range			-40		85	$^{\circ}$ C
Operating Relative Humidity Range, Non-condensing			10		90	%

### Notes:

1. The DNT24 achieves regulatory certification under FHSS rules.
2. Maximum sleep current occurs at +85  $^{\circ}$ C.



**CAUTION: Electrostatic Sensitive Device. Observe precautions when handling.**

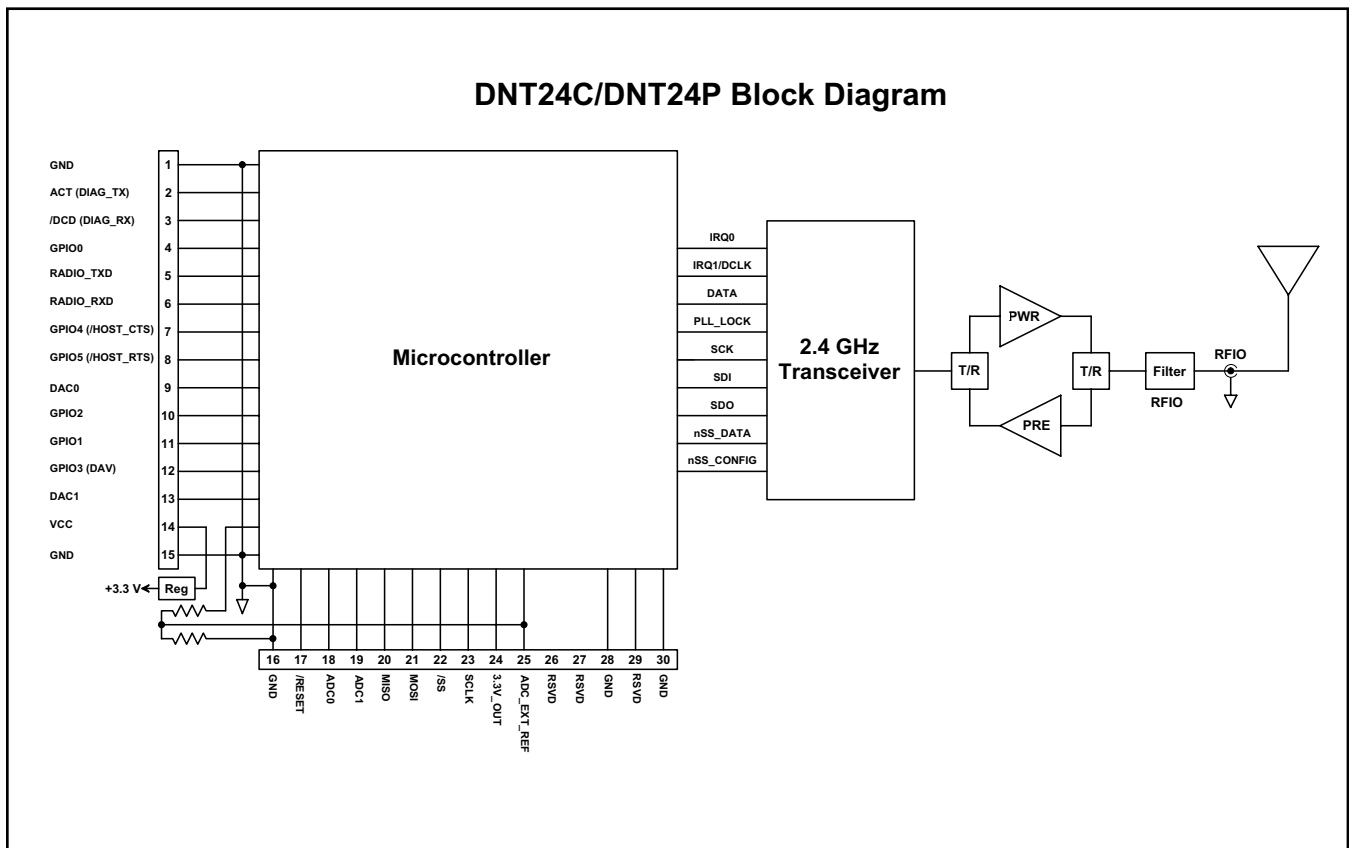

**Figure 1**

## DNT24 Hardware

The major components of the DNT24 include a 2.4 GHz FHSS transceiver and a low current 8-bit microcontroller. The DNT24 operates in the 2.4 GHz ISM band. There are 12 selectable hopping patterns providing compatibility with frequency allocations in most regions of the world. The DNT24 also has two selectable RF output power levels: 10 mW and 63 mW.

The DNT24 provides a variety of hardware interfaces. There are two serial ports plus one SPI port. Either the primary serial port or the SPI port can be selected for data communications. The second serial port is dedicated to diagnostics. The primary and diagnostic serial ports support most standard baud rates up to 250.0 kbps. The SPI port supports data rates up to 500 kbps. The DNT24 also includes three ADC inputs, two DAC outputs, and six general-purpose digital I/O ports. Four of the digital I/O ports support an optional interrupt-from-sleep mode when configured as inputs. The radio is available in two mounting configurations. The DNT24C is designed for solder reflow mounting.

The DNT24P is designed for plug-in connector mounting.

## DNT24 Firmware

DNT24 firmware operates using hybrid Ad Hoc TDMA channel access optimized for periodic burst transmissions. DNT24 firmware operates “out of the box” using point-to-point transparent serial mode, with point-to-multipoint, peer-to-peer and store & forward system topologies also supported.

DNT24 firmware provides the user with a rich set of configuration options including a choice of hopping patterns, hopping dwell times, serial and/or SPI data port operation, serial and SPI data rate selection, RF output power selection, plus configurable analog and digital I/O lines.

Data integrity is protected by 24-bit error detection, with optional ACK and automatic transmission retries or redundant transmissions. 128-bit AES encryption provides a high level of data security for sensitive applications. Sensor networks can take advantage of timer or event-based data reporting and remote node sleep cycling for extended battery life.

## DNT24 I/O Descriptions

Pin	Name	I/O	Description
1	GND	-	Power supply and signal ground. Connect to the host circuit board ground.
2	ACT (DIAG_TX)	O (O)	This pin's default configuration is data activity output. On a base, this signal blinks when a valid packet is received. On a remote, this signal blinks when a packet is transmitted. On a router, this signal blinks when a valid upstream packet is received or a downstream packet is transmitted. Alternate pin function is the diagnostic serial port output.
3	/DCD (DIAG_RX)	O (I)	This pin's default configuration is data carrier detect output. On a base, this signal is asserted when any valid packet is received, and is cleared if no packets are heard for the configured router/remote registration time-out interval. On a router or remote, this signal is asserted when the radio obtains hopping pattern synchronization, and remains asserted until no beacons are heard for 50 hops. Alternate pin function is the diagnostic serial port input.
4	GPIO0	I/O	Configurable digital I/O port 0. When configured as an input, an internal pull-up resistor can be selected and direct interrupt from sleep can be invoked. When configured as an output, the power-on state is configurable. In sleep mode the pin direction, input pull-up selection or output state are also separately configurable.
5	RADIO_TXD	O	Serial data output from the radio.
6	RADIO_RXD	I	Serial data input to the radio.
7	GPOI4 (/HOST_CTS)	I/O (O)	Default pin function is GPIO4 with the same configuration options as GPIO0. Alternate pin function is UART/SPI flow control output. The module sets this line low when it is ready to accept data from the host on the RADIO_RXD or MOSI input. When the line goes high, the host must stop sending data.
8	GPOI5 (/HOST_RTS)	I/O (I)	Default pin function is GPIO5 with the same configuration options as GPIO0. Alternate pin function is UART/SPI flow control input. The host sets this line low to allow data to flow from the module on the RADIO_TXD pin. When the host sets this line high, the module will stop sending data to the host.
9	DAC0	O	12-bit DAC 0 output. Full scale output can be referenced to the voltage at pin 25 or the 3.3 V regulated module bus voltage.
10	GPIO2	I/O	Configurable digital I/O port 2. Same configuration options as GPIO0.
11	GPIO1	I/O	Configurable digital I/O port 1. Same configuration options as GPIO0.
12	GPIO3 (DAV)	I/O (O)	Default pin function is GPIO3 with the same configuration options as GPIO0. When SPI slave mode operation is enabled, a logic high on this pin indicates when data is available to be clocked out by the SPI master.
13	DAC1	O	12-bit DAC 1 output. Same specifications and configuration options as DAC0.
14	VCC	I	Power supply input, +3.3 to +5.5 Vdc.
15	GND	-	Power supply and signal ground. Connect to the host circuit board ground.
16	GND	-	Power supply and signal ground. Connect to the host circuit board ground.
17	/RESET	I	Active low module hardware reset.
18	ADC0	I	ADC input 0. This pin is a direct ADC input when the ADC is operating in single-ended mode, or the differential negative input for positive inputs applied to ADC1 or ADC2 when the ADC is operating in differential mode. Full-scale reading can be referenced to Pin 25 for ratiometric measurements. For absolute measurements, the ADC can use either the regulated supply voltage divided by 1.6 (about 2.06 V), or an external voltage applied to Pin 25. In single-ended mode, ADC measurements are 11-bit unsigned values with full scale nominally 2.7 V when referenced to a 2.7 V input on Pin 27. In differential mode, ADC measurements are 12-bit signed values.
19	ADC1	I	ADC input 1. Direct input when the ADC is operating in single-ended mode, positive differential input relative to ADC0 when the ADC is operating in differential mode.
20	MISO	I/O	This pin is the SPI master mode input or slave mode output.
21	MOSI	I/O	This pin is the SPI master mode output or slave mode input.
22	/SS	I/O	SPI active low slave select. This pin is an output when the module is operating as a master, and an input when it is operating as a slave.

Pin	Name	I/O	Description
23	SCLK	I/O	SPI clock signal. This pin is an output when operating as a master, and an input when operating as a slave.
24	ADC2	I	ADC input 2. Direct input when the ADC is operating in single-ended mode, positive differential input relative to ADC0 when the ADC is operating in differential mode.
25	ADC_EXT_REF	I/O	ADC external reference voltage pin. The voltage at this pin can be used by the ADCs as a reference for ratiometric measurements. With no external voltage or load applied, this pin presents a nominal 2.7 V output through a 2.126 K source resistance. A low impedance external reference voltage in the range of 1 to 2.7 V may be applied to this pin as an option.
26	RSVD	-	Reserved pin. Leave unconnected.
27	RSVD	-	Reserved pin. Leave unconnected.
28	GND	-	Connect to the host circuit board ground plane.
29	RSVD	-	Reserved pin. Leave unconnected.
30	GND	-	Connect to the host circuit board ground plane.

## DNT24 Antenna Connector

A U.FL miniature coaxial connector is provided on both DNT24 configurations for connection to the RFIO port. A short U.FL coaxial cable can be used to connect the RFIO port directly to an antenna. In this case the antenna should be mounted firmly to avoid stressing the U.FL coaxial cable due to antenna mounting flexure. Alternately, a U.FL coaxial jumper cable can be used to connect the DNT24 module to a U.FL connector on the host circuit board. The connection between the host circuit board U.FL connector and the antenna or antenna connector on the host circuit board should be implemented as a 50 ohm stripline. Referring to Figure 2, the width of this stripline depends on the thickness of the circuit board between the stripline and the groundplane. For FR-4 type circuit

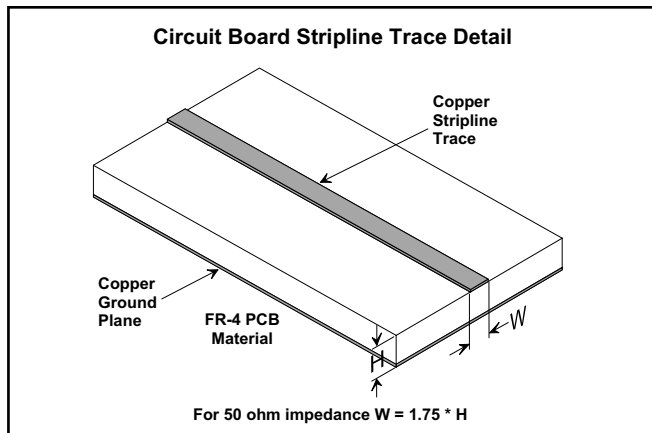

**Figure 2**

Trace Separation from 50 ohm Microstrip	Length of Trace Run Parallel to Microstrip
100 mil	125 mil
150 mil	200 mil
200 mil	290 mil
250 mil	450 mil
300 mil	650 mil

**Figure 3**

board materials (dielectric constant of 4.7), the width of the stripline is equal to 1.75 times the thickness of the circuit board. Note that other circuit board traces should be spaced away from the stripline to prevent signal coupling, as shown in Figure 3. The stripline trace should be kept short to minimize its insertion loss.

### DNT24C Outline and Mounting Dimensions

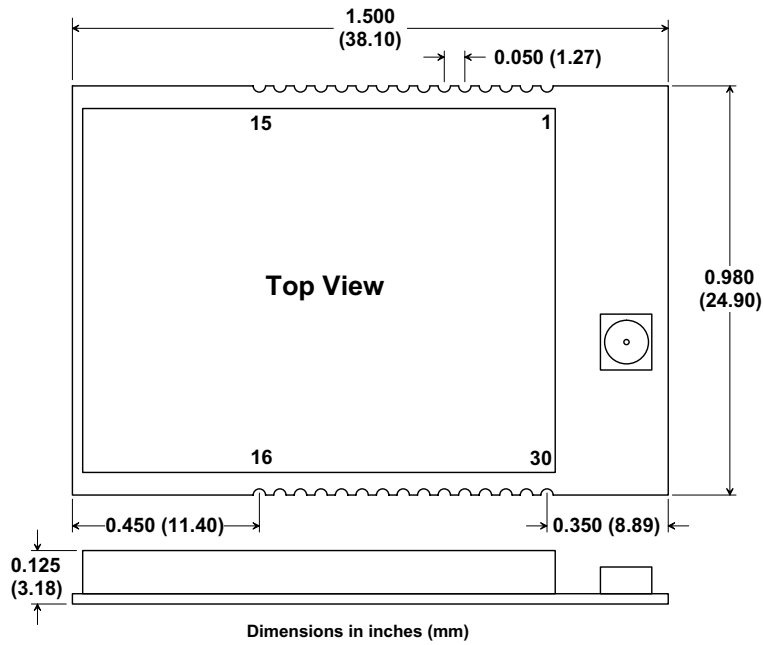

Figure 4

### DNT24C Solder Pad Dimensions

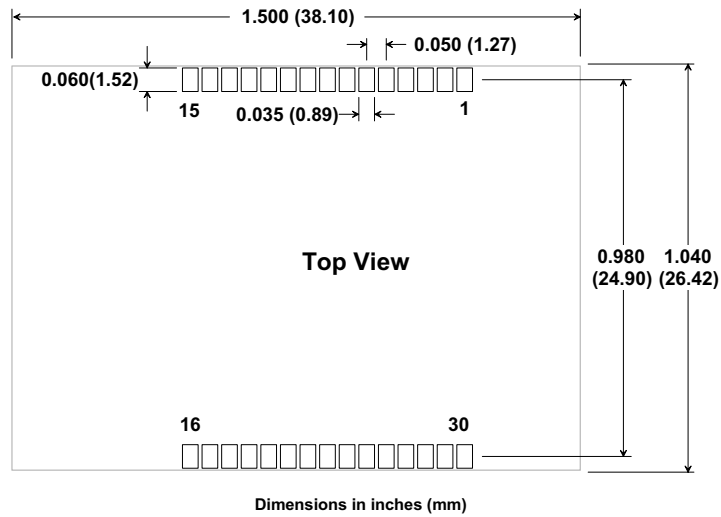
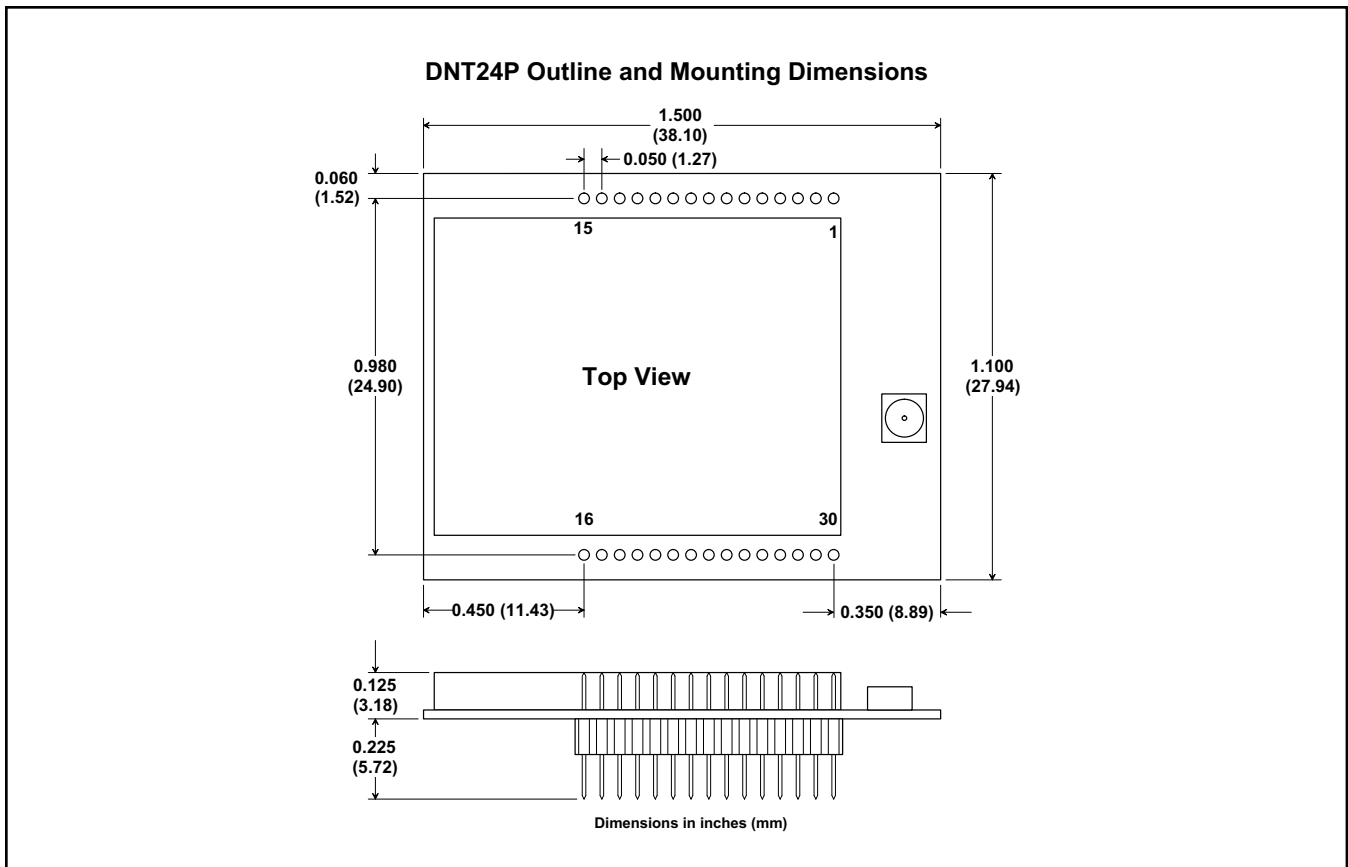
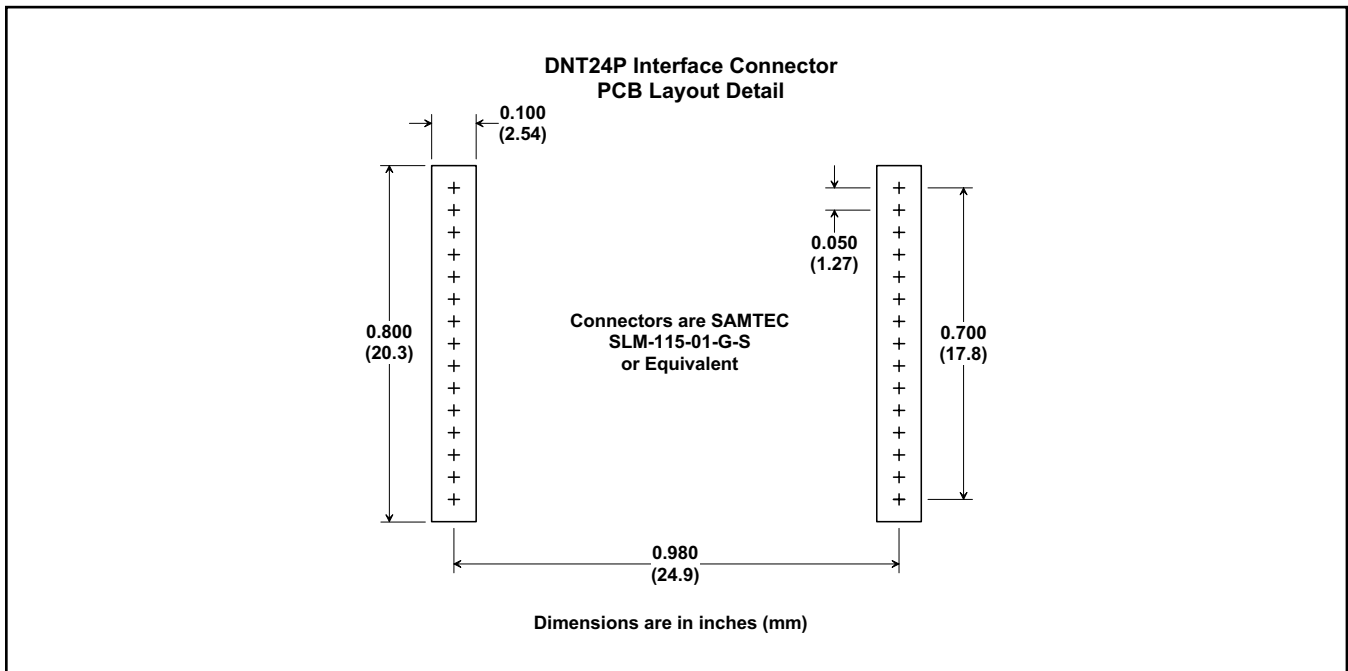

Figure 5



**Figure 6**



**Figure 7**

Note: Specifications subject to change without notice.

Part # M-0024-0000, Rev B