

## SPECIFICATION

- Part No. : **PC24.07.0100A**
- Product Name : **TheStripe™** 850/900/1800/1900MHz GSM PCB Antenna  
100mm Ø1.13mm IPEX MHF connector (U.FL)
- Features : 42mm\*42mm\*1.6mm  
Compatible with Hirose U.FL  
**RoHS Compliant**

Photo:

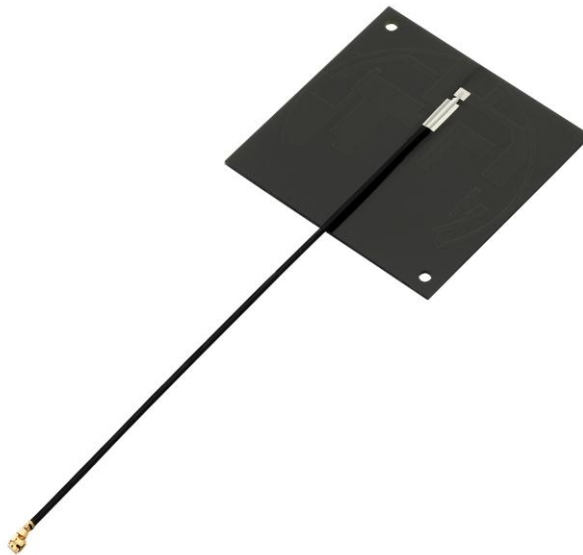

## I. Introduction

The PC24 Internal PCB Antenna is a compact square Quad-band GSM antenna for incorporation in antennas and transceiver modules to be used worldwide. Omni-directional gain across all bands ensures constant reception and transmission. Cables and connectors are fully customizable. Antennas can be tuned to customer housing on request.

## II. Typical Antenna Performance in free space

<b>Specifications</b>				
<b>ELECTRICAL</b>				
	<b>AMPS</b>	<b>GSM</b>	<b>PCS</b>	<b>DCS</b>
Band	824-896	880-960	1850-1990	1710-1880
Return Loss	-12 dB	-25 dB	-12 dB	-10 dB
Gain	Average 0 dBi			
Polarization	Linear			
Impedance	50 ohms			
Input Power	10 watts			
Input Connection	Coaxial Cable – IpeX 1.13 100mm MHF Standard, Fully customizable			
VSWR (Min performance)	<2.0:1			
<b>MECHANICAL</b>				
Dimensions (L x W)	42 mm x 42mm			

**\*note: specifications may be subject to change**

### III. Outline Drawing

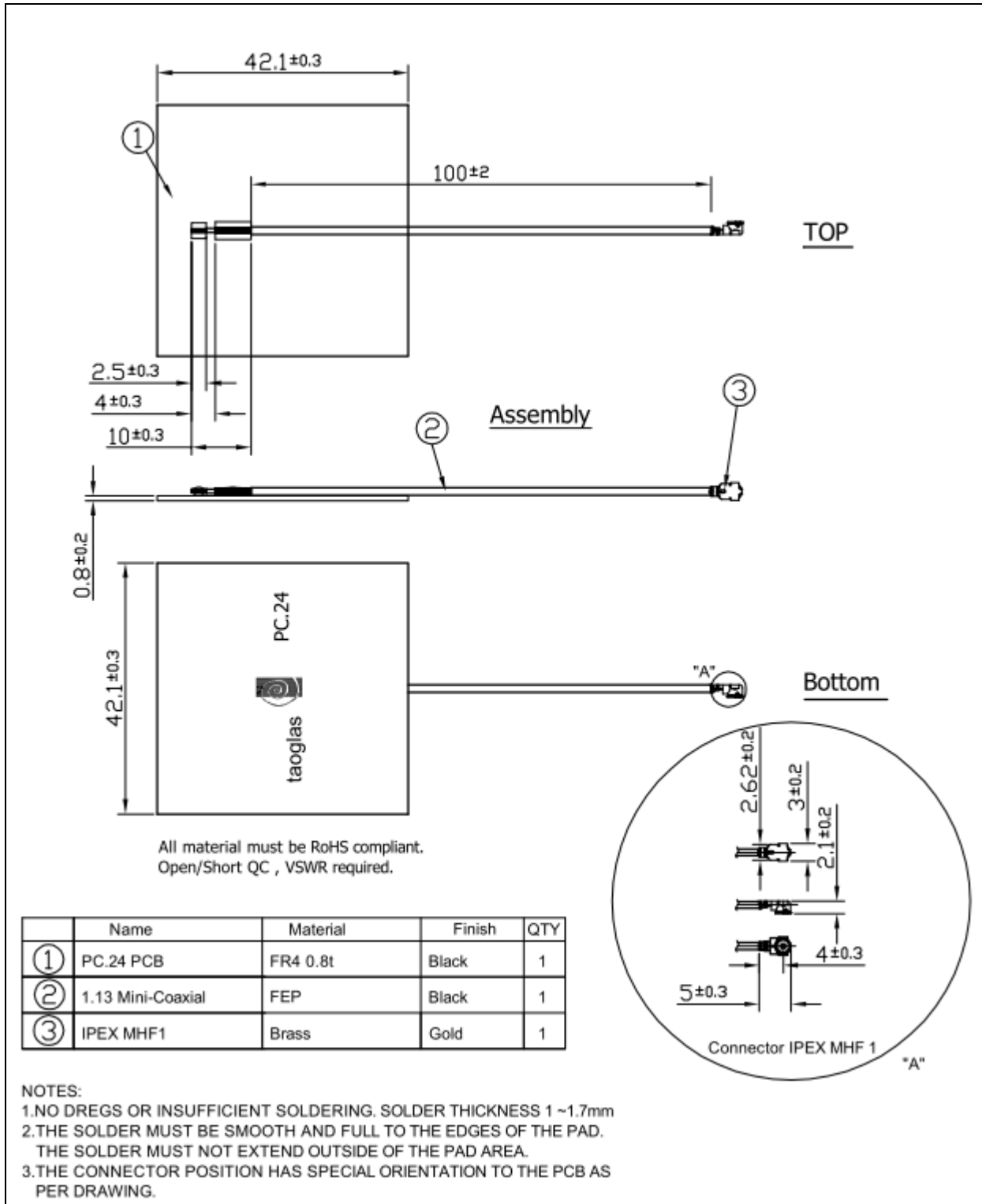

## IV. S11 Magnitude

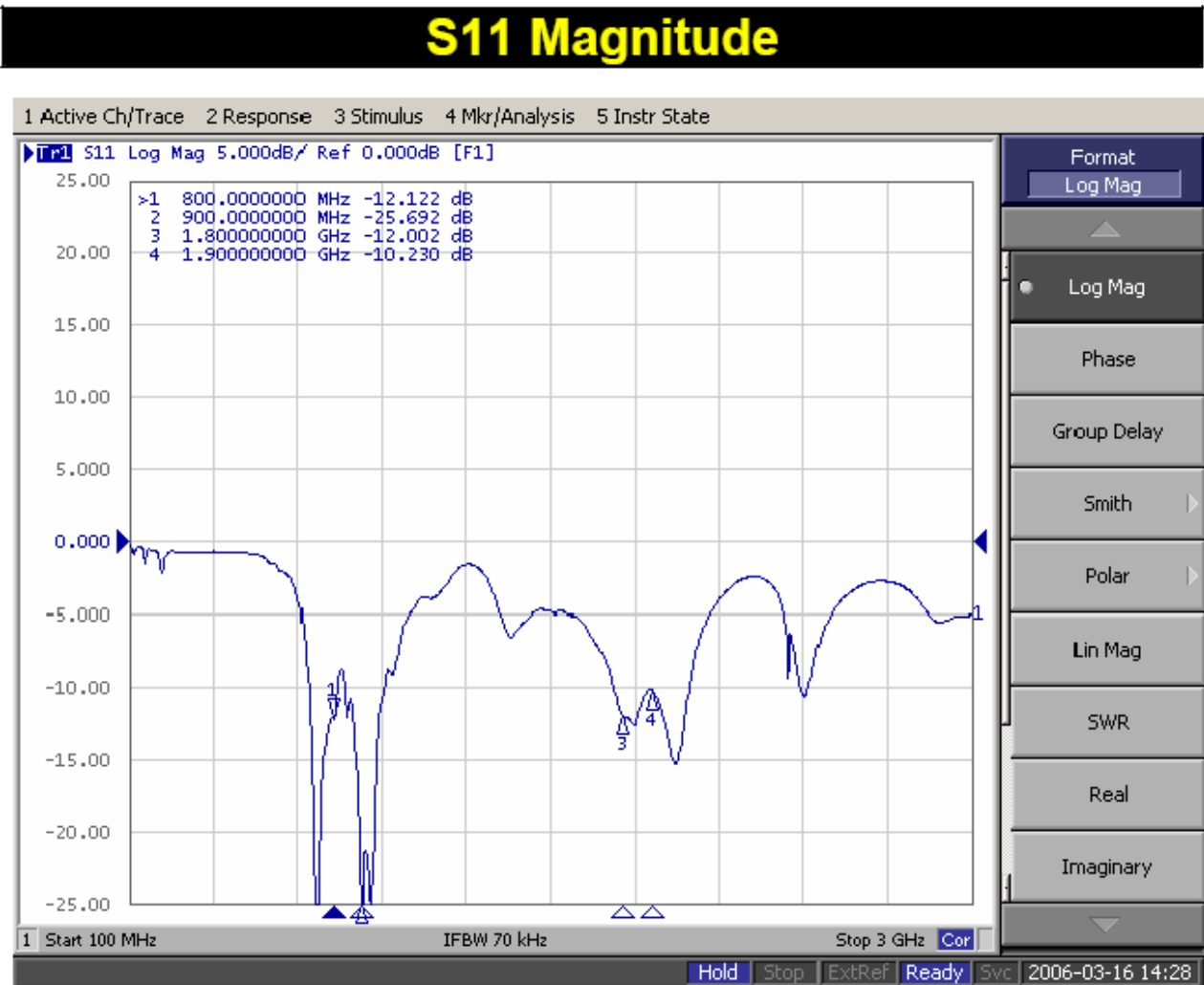

# V. Radiation Patterns

## 800 MHz – 3D Radiation Pattern

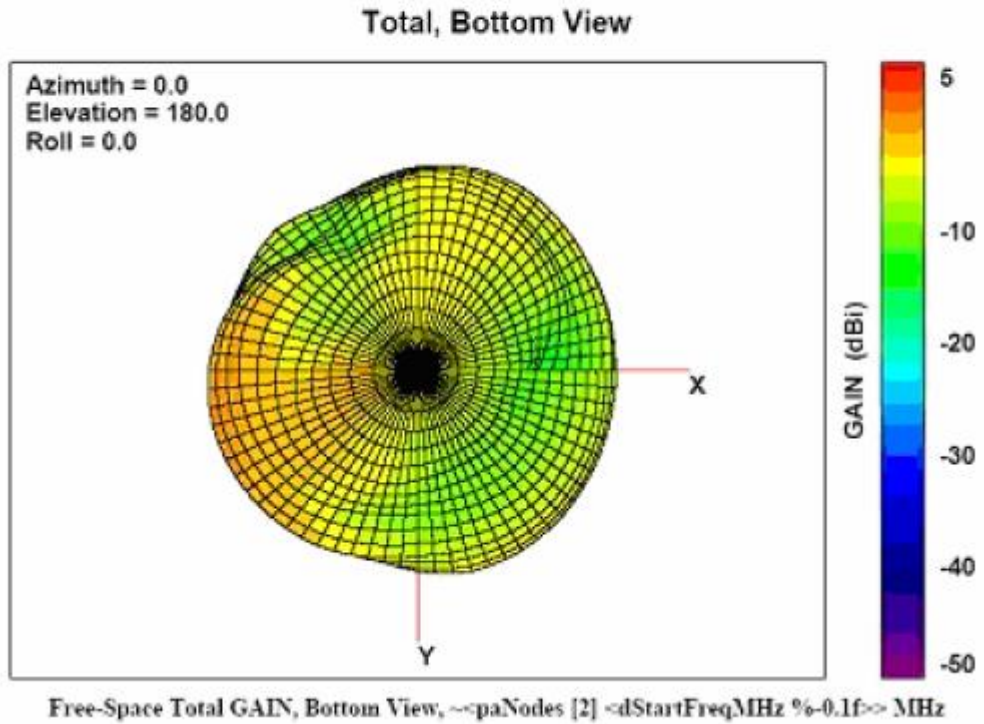

# 900 MHz – 3D Radiation Pattern

Total, Bottom View

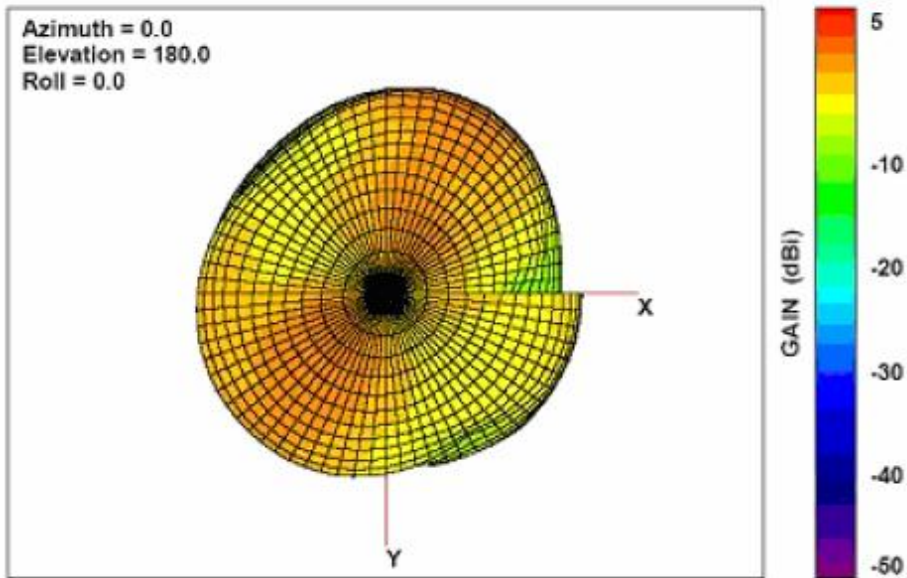

Free-Space Total GAIN, Bottom View, 900.0 MHz

# 1800 MHz – 3D Radiation Pattern

Total, Bottom View

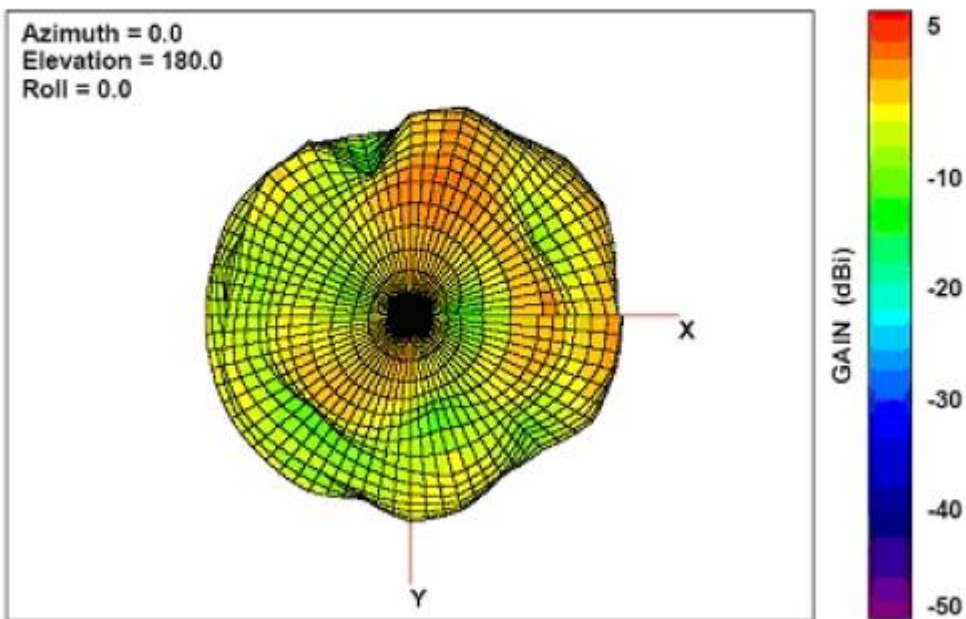

Free-Space Total GAIN, Bottom View, 1800.0 MHz

# 1900 MHz – 3D Radiation Pattern

