



TS6B01G - TS6B07G

Single Phase 6.0 Amps.
Glass Passivated Bridge Rectifiers

TS4B

Features

- ✧ UL Recognized File # E-96005
- ✧ Glass passivated junction
- ✧ Ideal for printed circuit board
- ✧ Reliable low cost construction
- ✧ Plastic material has Underwriters Laboratory Flammability Classification 94V-0
- ✧ Surge overload rating to 150 amperes peak
- ✧ High case dielectric strength of 2000V_{RMS}
- ✧ High temperature soldering guaranteed:
260°C / 10 seconds / 0.375" (9.5mm) lead length at 5 lbs (2.3Kg) tension

Mechanical Data

- ✧ Case: Molded plastic
- ✧ Terminals: Leads solderable per MIL-STD-750, Method 2026
- ✧ Weight: 0.15 ounce, 4 grams
- ✧ Mounting torque: 5 in. lbs. max.

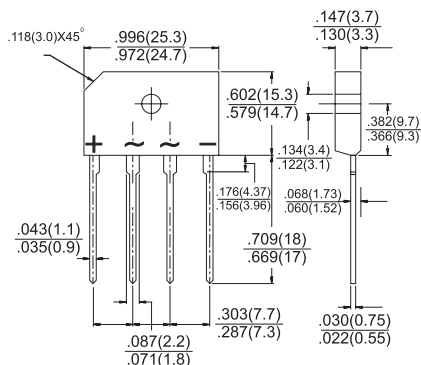

Dimensions in inches and (millimeters)

Maximum Ratings and Electrical Characteristics

Rating at 25°C ambient temperature unless otherwise specified.

Single phase, half wave, 60 Hz, resistive or inductive load.

For capacitive load, derate current by 20%

Type Number	Symbol	TS6B01G	TS6B02G	TS6B03G	TS6B04G	TS6B05G	TS6B06G	TS6B07G	Units
Maximum Recurrent Peak Reverse Voltage	V_{RRM}	50	100	200	400	600	800	1000	V
Maximum RMS Voltage	V_{RMS}	35	70	140	280	420	560	700	V
Maximum DC Blocking Voltage	V_{DC}	50	100	200	400	600	800	1000	V
Maximum Average Forward Rectified Current See Fig. 2	$I_{(AV)}$	6.0							A
Peak Forward Surge Current, 8.3 ms Single Half Sine-wave Superimposed on Rated Load (JEDEC method)	I_{FSM}	150							A
Maximum Instantaneous Forward Voltage @ 3.0A @ 6.0A	V_F	1.0 1.1							V
Maximum DC Reverse Current @ $T_A=25^\circ\text{C}$ at Rated DC Blocking Voltage @ $T_A=125^\circ\text{C}$	I_R	5.0 500							μA μA
Typical Thermal Resistance (Note)	$R_{\theta JC}$	1.5							$^\circ\text{C}/\text{W}$
Operating Temperature Range	T_J	-55 to +150							$^\circ\text{C}$
Storage Temperature Range	T_{STG}	-55 to +150							$^\circ\text{C}$

Note: Thermal Resistance from Junction to Case with Device Mounted on 2" x 3" x 0.25 Al-Plate Heatsink.

RATINGS AND CHARACTERISTIC CURVES (TS6B01G THRU TS6B07G)

FIG.1- MAXIMUM FORWARD CURRENT DERATING CURVE

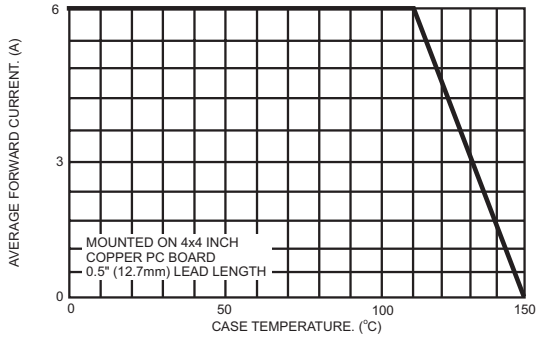

FIG.2- TYPICAL REVERSE CHARACTERISTICS PER BRIDGE ELEMENT

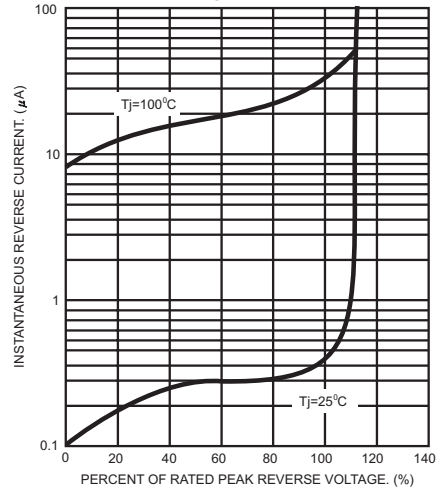

FIG.3- MAXIMUM NON-REPETITIVE FORWARD SURGE CURRENT PER BRIDGE ELEMENT

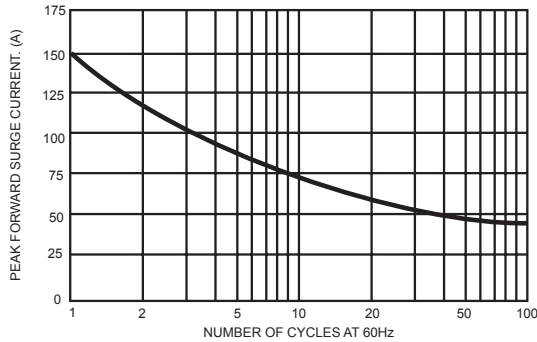

FIG.4- TYPICAL JUNCTION CAPACITANCE

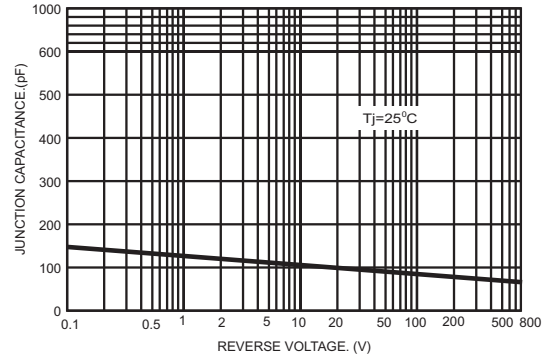

FIG.5- TYPICAL FORWARD CHARACTERISTICS PER BRIDGE ELEMENT

